

Manifold pressure regulator ADR 150 / 150F

Complete solution to reduce pressure in acetylene supplies
30–150 m³/h (1060–5295 sqfh)

ADR 150 dome pressure regulator

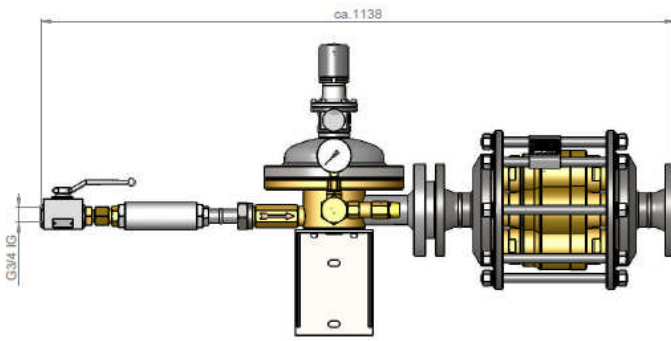

Slam shut valve
HDS 17

Dome
pressure regulator
ADR 150

Safety group
645
(z. B. 4 x 85-30)

ADR 150F pressure regulator

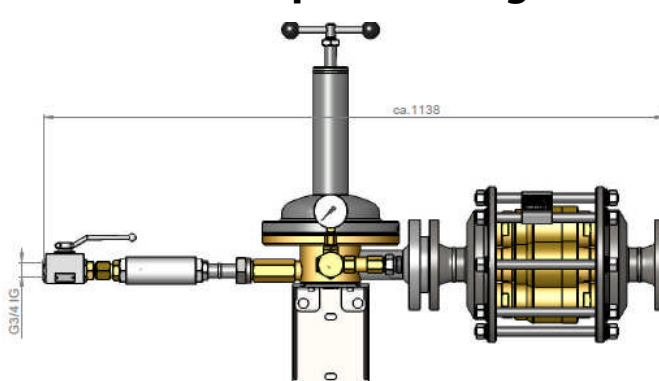

Slam shut valve
HDS 17

Pressure regulator
ADR 150F

Safety group
645
(z. B. 4 x 85-30)

Benefits:

- Complete solution, ready for installation
- Inclusive pressure regulator, flashback arrestor, ball valve, slam shut valve, wall mounting panel
- Max. inlet pressure 25 bar (362 psi), working pressure 0-1.5 bar (0-21 psi)
- Flow rate 30-150 m³/h (1060–5295 sqfh)
- Low pressure drop – optimal draining of the manifold or bundle reduces costs
- According to all relevant standards, e.g.:
 - DIN EN ISO 14114
 - DIN EN ISO 15615
 - DIN EN ISO 7291
 - DIN EN 730-1 / ISO 5175
 - EIGA
 - TRAC
 - CE

OUR PRODUCT RANGE

Gas Control Equipment

- Gas mixing systems
- Gas metering systems
- Gas analyzers
- Leak detection systems
- Gas pressure vessels
- Engineering of customized systems

Gas Safety Equipment

- Flashback arrestors
- Non-return valves
- Quick couplers
- Safety valves
- Stainless steel devices
- Gas filters
- Pressure regulators
- Lance holders
- Ball valves
- Automatic hose reels
- Test equipment
- Accessories
- Customized safety equipment



WITT-Gasetechnik GmbH & Co KG

Salinger Feld 4-8 • 58454 Witten
Postfach / POB 2550 • 58415 Witten
Tel.: +49 (0) 2302 8901-0 • Fax: +49 (0) 2302 8901-3
www.wittgas.com • witt@wittgas.com