

New Subsea Node



Texcel
Technology

Electronic
Manufacturing
Solutions

UK Based. UK Manufacture.
Selling throughout the World.

New Subsea Node

Texcel Technology Plc is pleased to announce the launch of its new Subsea Node, adding to the company's successful suite of design and manufacturing solutions for challenging sub sea environments.

Texcel is a major solutions provider for NEPTUNE and RSN, subsea cabled observation systems and has designed this new version of the Node to meet the requirements of the Marine Institute of Ireland, Galway Bay project, and supports Texcel's family of coastal and deep water ocean observation solutions.

Texcel's latest subsea Node is based upon the 100% reliability success of the company's previous projects. It has the following configurable options, based upon a modular design concept, which is compatible with repeated and non-repeated networks:

- Operational Depths from 500M to 2500M, is offered as standard, with a Titanium housing approved to NAVSEA 9290
- Up to 23 configurable scalable output ports, each galvanically switched and fully protected against short circuits, offering voltages of 400V, 48V, 24V, 15V and 12v DC, with output isolated options.
- The 400V output port has been rated at 28 Amp switching, with high speed short circuit switch-off protection.
- The lower voltage outputs can deliver up to 600 Watts of power and operate in constant voltage mode until the power limit is reached, and they then go into constant current mode, fully short circuit proof.

The Node has a wide input voltage range from 300 V DC to 450 VDC with over voltage protection and snubber circuits built-in.

Each output port has a range of measurements which include, output current, peak current, leakage current and actual voltage. Each measured value has the options to set high and low warning limits and high and low alarm limits.

The Node also has a series of environmental sensors including, 3 temperature, 1 pressure, pitch and roll and humidity. These also have configurable warning and alarm limits.

Image Description

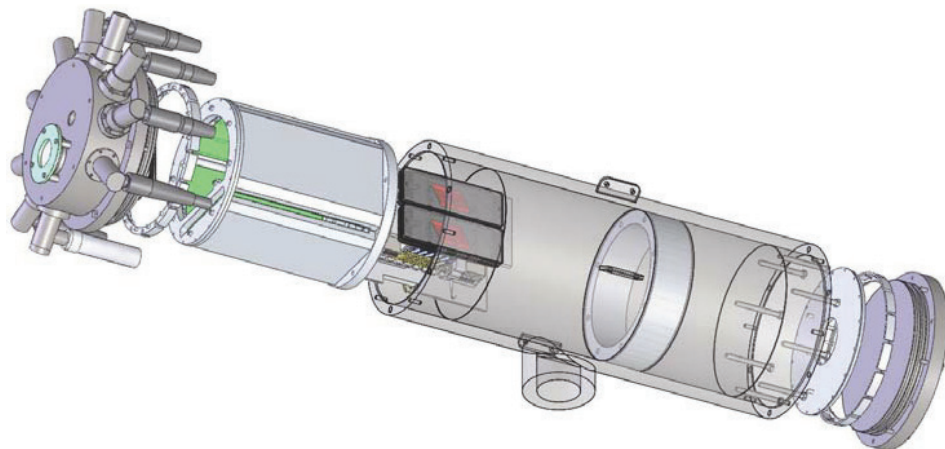

New Subsea Node

The communications to each port include 10/100 Ethernet, or serial with configurable Rs232, 485 and 422 modes. The communication channels can be fully redundant or single sided, and are isolated giving improved reliability under external fault conditions.

With a wide operational temperature range and a 25 year design, this Node is a robust solution for many applications. Texcel are able to re-engineer aspects of the system to meet specific end user applications.

The Nodes communicate to the Texcel's element management software either inbound or out of bound of the science port data, operating into either a single server or mirrored server configuration with automatic IP distribution. During periods of communications loss the Node will continue to operate safely, whilst storing the data for later onward transmission to the server.

Texcel's Primary Node Controller (PNC) element software makes the management of multiple Nodes a simple task, with automatic data storage, dynamic graphical displays and graphing built in. The system provides real world values so it is simple to analyse, and intuitive to manage and operate. The PNC is based upon a SQL database with optional server mirroring if required. The PNC also has a Northbound XML interface for a top level management system.

Texcel are also able to supply a fully integrated management system that manages multi-vendor equipment across different equipment types providing a complete infrastructure view through one portal. This includes the PNC, SNMP managed equipment and a wide variety of equipment types using non-stand protocols. Coupled with dynamic equipment images, and tables with a full historical log, the whole system can be managed and analysed through one system.

To support these projects Texcel have undertaken the validation testing and documentation. Texcel have also developed the software management tools required to operate the equipment in a reliable manner inclusive of the element managers and the system network managers.

Image Description



Specification

System Specification which is customer configurable. For alternative options please contact the factory.

Feature	Standard Value	Comments
Operational Input Voltage	250 – 420 V DC	Options available
Maximum Input Voltage	480 VDC	
Science Port Outputs	12v @ 5A	
	15v @ 4A	
	24v @ 2.5A	Option for 25 Amp Version
	26v @ 6A	
	48v @ 1.5A	Option for 12.5 Amps
	400v @ 20A	
Output Short Circuit	10% of max current	400v is fixed at 45 Amps
Output Over Current	0 – Max Current +/- 0.1A	Software Configurable
Output Current Measurement	0 – Full Load +/-100mA	Warning and Fault Alarms
Output Leakage Current	0 – Max Leakage	Software Configurable
Output Off Isolation	>10MOhms @ 500V	Full Galvanic Isolation
Science port Communications	Optical Ethernet Electrical Ethernet Serial 232/422/485	Selectable per port
Internal Pitch & Roll	+/- 1 Deg on two axis	
Internal Temperature	+/-1 Deg C	3 separate sensors
Internal Humidity	+/- 1% RH	
Internal Voltage Alarm	+/-10% of set point	Alarms when out of range
System Communications	Dual IP path	Inbound or OutBound Options
System Control	Dual multitasking systems	
Element Manager	Self starting SQL data storage with User GUI	Stand along or Mirrored server options

Texcel Technology Electronic Manufacturing Solutions

Texcel Technology Plc
Thames Road
Crayford
KENT DA1 4SB
United Kingdom

www.texceltechnology.com

Enquiries: +44 (0)1322 621700