



www.ikonltd.com

Shelving Catalogue

What's inside?

Here at Ikon we cover a whole range of shelving sectors from high-street retailers through to builders merchant shelving and everything in-between.

Retail Shelving

We know how important it is for you to make a great first impression with your customers that's why our retail shelving units are designed around your unique requirements.

GO TO PAGE [3](#)

Pharmaceutical Shelving

Our pharmaceutical shelving range is perfectly designed to fit beautifully in any size pharmaceutical, cosmetic or health and beauty retailer store.

GO TO PAGE [7](#)

Builders Merchant Shelving

Ikon builders merchant shelving is designed to hold high-capacity, heavy duty loads with ease - making it the perfect solution for hardware, electrical and builders merchant locations.

GO TO PAGE [11](#)

About Ikon

Built on a solid foundation of years of industry experience, Ikon Ltd in Nottingham is the perfect partner to help you find the best storage solutions for your business. Our team of industry professionals will go the extra mile to ensure complete satisfaction, whether that's with a product purchased on our website or a full bespoke service. Our industry experience allows you to sit back knowing you're in capable hands.

Here at IKON Pallet Racking and Storage Solutions in Nottingham we provide a complete service, from initial quotation through to design, manufacture and installation from our Head office in Nottinghamshire, ensuring you have a hassle-free service.

Call us now to discuss your bespoke shelving solutions with our design team.



Safe contractor approved



All installers are SEIRS qualified

Retail Shelving

Here at Ikon we offer a range of bespoke Retail Shelving designed to fit beautifully within your store. Each shelving project is started with a blank piece of paper and designed with your requirements in mind. We offer every type of shelving from standard product and promotion shelving units - through to stunning refrigerated units.



FREE CAD DESIGN



FREE ON-SITE CONSULTATION







Proudly working alongside



Our Retail Shelving units are ideal for creating highly-flexible, sturdy and easily adjustable meaning you can create a retail space bespoke to you and rearrange this whenever needed. Our retail shelving units are perfect for supermarkets, high-street retailers, trade counters and more.

We know how important it is for you to make a great first impressions with your customers and for that reason each and every shelving unit we make is crafted individually to meet your unique requirements. Ikon retail shelving systems are manufactured in Italy and complies with all UK and EU safety legislation



FREE CAD DESIGN



FREE ON-SITE CONSULTATION

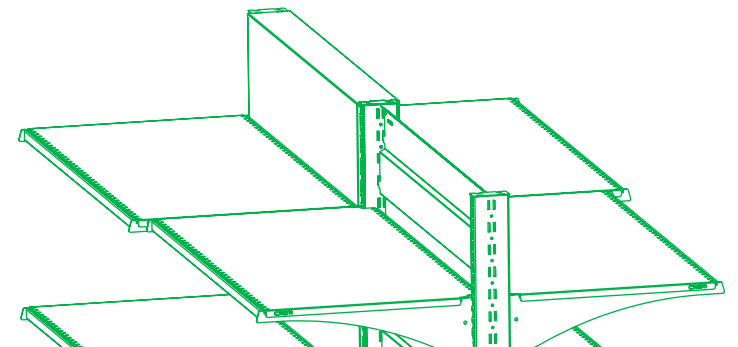



Simple & Quick Assembly

Our shelving units are simple and easy to assemble. If your shelving requirements grow the units are easily extendable meaning you can arrange your units however you like.

- i** SIMPLE TO ASSEMBLE
- i** EASILY ADJUSTABLE ARRANGEMENT



Easy To Maintain

Ikon shelving units are finished with a smooth finish to ensure a quality, modern look whilst maintaining an easy to clean surface area.

- i** EASY TO CLEAN
- i** UPRIGHT DESIGN



High-load Capacity

These retail shelving units are equipped with reinforced steel uprights allowing you to use these shelves for both high-load and heavy-duty products.

- i** UPRIGHT DESIGN
- i** UPRIGHT DESIGN

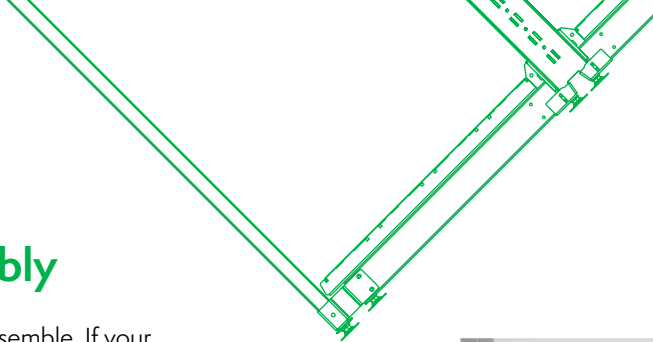

Pharmaceutical Shelving

Ikon pharmaceutical shelving uses a 50mm pitch system - making it compatible with existing shelving units used throughout Europe. Ideal for product storage or customer facing displays and promotional products our shelving units are highly-flexible and easily adjustable to suit your needs so whether you're looking to refurbish a current store or you are relocation look no further thank Ikon.



FREE CAD DESIGN



FREE ON-SITE CONSULTATION





Proudly working alongside



Ikon pharmaceutical shelving range is a flexible system designed to be used in-store and is therefore easily maneuverable whenever a store overhaul is needed. This range of system is constructed in Italy and complies with all UK and EU safety legislation.

Our in-house design team will help you to create a bespoke shelving system that suits your beautifully - with custom sizes, shelving depths and colours available we guarantee to provide a modern store revamp that you're over the moon with.



FREE CAD DESIGN



FREE ON-SITE CONSULTATION

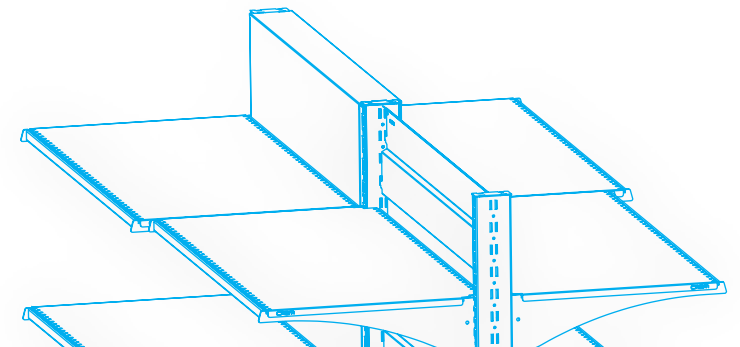



Simple & Quick Assembly

Our shelving units are simple and easy to assemble. If your shelving requirements grow the units are easily extendable meaning you can arrange your units however you like.

i UPRIGHT DESIGN **i** UPRIGHT DESIGN



Hardwearing Design

Ikon shelving units are finished with a smooth finish to ensure a quality, modern look whilst maintaining an easy to clean surface area.

i UPRIGHT DESIGN **i** UPRIGHT DESIGN



High-load Capacity

These retail shelving units are equipped with reinforced steel uprights allowing you to use these shelves for both high-load and heavy-duty products.

i UPRIGHT DESIGN **i** UPRIGHT DESIGN

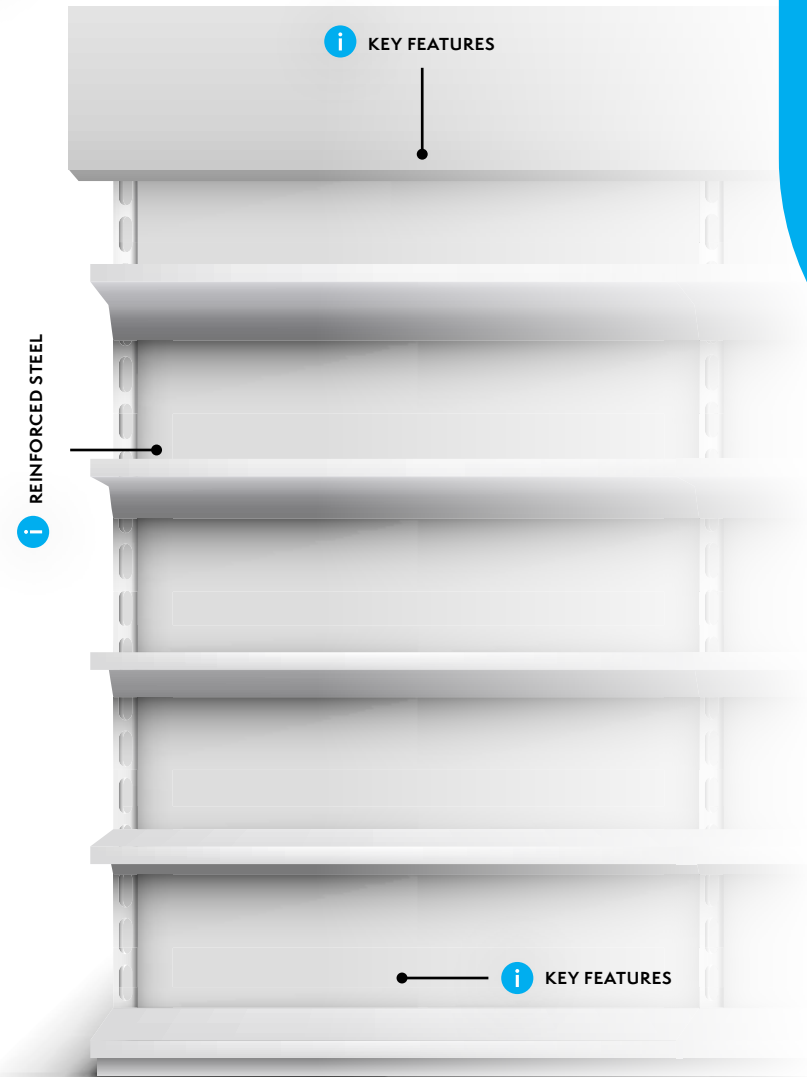
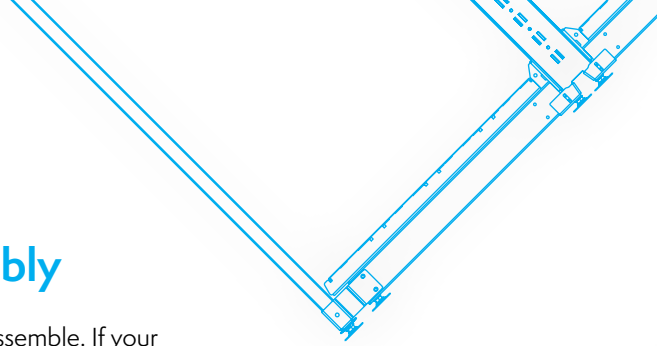

Builders Merchant Shelving

Our range of builders merchant shelving is the perfect solution for hardware stores, electrical stores and builders merchants. Constructed using superior-grade reinforced steel these shelves are designed to withstand rigorous environments and hold a high-capacity of heavy loads at any one time.



FREE STORE CAD DESIGN



FREE ON-SITE CONSULTATION







Proudly working alongside



Built to withstand the test of time under vigorous conditions - our heavy-duty shelving systems are the perfect fit for everyone from in-store backroom storage through to in-store product shelving and everything in-between.

Our in-house design team will help you to create a bespoke storage arrangement that suits you and your product requirements down to the ground. Each project starts with a blank piece of paper to ensure we achieve the best results possible. Ikon covers everything from initial design, through to manufacture, installation and aftercare services.



FREE CAD DESIGN



FREE ON-SITE CONSULTATION

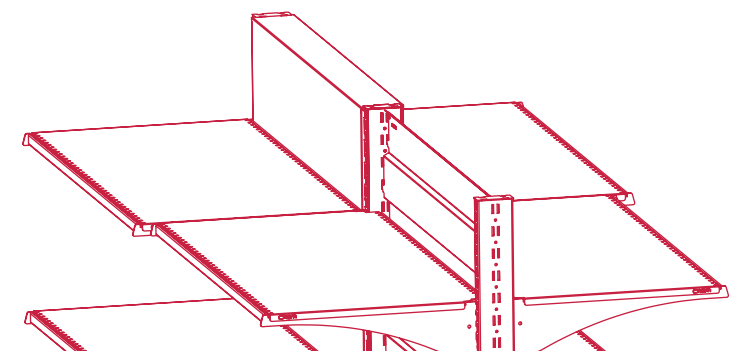

Simple & Quick Assembly

Our shelving units are simple and easy to assemble. If your shelving requirements grow the units are easily extendable meaning you can arrange your units however you like.

i UPRIGHT DESIGN **i** UPRIGHT DESIGN

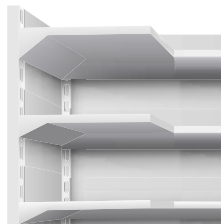

Rigorous Design

Ikon shelving units are finished with a smooth finish to ensure a quality, modern look whilst maintaining an easy to clean surface area.

i UPRIGHT DESIGN **i** UPRIGHT DESIGN



High-load Capacity

These retail shelving units are equipped with reinforced steel uprights allowing you to use these shelves for both high-load and heavy-duty products.

i UPRIGHT DESIGN **i** UPRIGHT DESIGN





Proudly working alongside



 www.ikonltd.co.uk

|  sales@ikonltd.co.uk

|  01773 718 719