

column casing solutions



circa



quadra



forma



polyma



gypra



metza

en casement

sustainable building solutions

Encasement's approach of providing innovative high quality products at competitive prices, supported by outstanding service, has enabled us to become the fastest growing company in the decorative casings and protection sector.

In addition to our core products, we have continued to develop and expand our range to meet the growing demand for sustainable building products, including FSC® compliant materials from sustainable sources, which comply with the relevant codes of practice and help improve BREEAM points ratings.

This focus on sustainability is also reflected in other materials we use within our product range. Aluminium is one of the most widely recycled materials and is used extensively in our Forma column casings together with steel. Beyond this, we also use 'EkoBlend' in our wall protection products, which is 100% recyclable and contains no PVC.

Our range is now the most comprehensive available and is supported by our high quality manufacturing, logistics, installation and customer services, which combine to deliver a complete solution for architects, specifiers and installers working in all aspects of building design and construction.

We're also continuing to develop new products and services to extend the scope even further and enhance our 'integrated solutions' capabilities.



contents

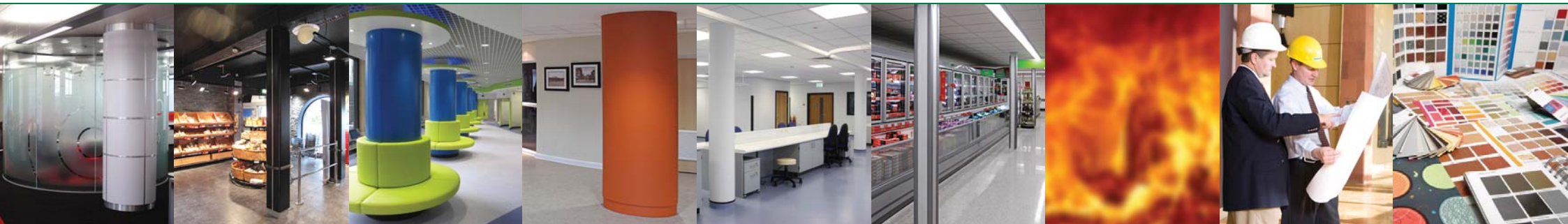

circa 4-7		quadra 8-11		forma 12-15		polyma 16-19		gypra 20-22		metza 23-25		fire protection 26		installation 27		finishes 28
--------------	--	----------------	--	----------------	--	-----------------	--	----------------	--	----------------	--	-----------------------	--	--------------------	--	----------------

Circa

plywood column casings

The n-case Circa range of circular pre-formed ply column casings provide one of the simplest, quickest and most cost-effective method of enclosing interior structural columns within buildings.

Covering diameters from 250mm to 1200mm, Circa column casings are available in a choice of laminated or real wood veneer finishes as well as a plain option for on-site finishing. In addition, our 'ex-stock' products within the range can be delivered next working day. Circa also includes 'extended circle' designs to allow the casings to easily cover building services fixed to structural columns.

Beyond this, our Circa range provides a high degree of flexibility in design and finish to match the most demanding project specifications, providing an excellent combination of durability, aesthetics, versatility and ease of installation.

Consequently, Circa casings are already used in a wide range of sectors from offices, leisure, retail and education as well as healthcare and sports stadia. Installation is also quick and simple as Circa casings are a single fix dry trade solution which saves time on-site.

- * Cost effective method of covering structural columns
- * Standard column casing range available in 3000mm lengths
- * Ex-stock - next working day delivery
- * Choice of plain, laminated and veneer finishes
- * Quick and easy to install
- * Single fix dry trade solution

Click [here](#) for supply and install info.





Circa

specifications and technical data

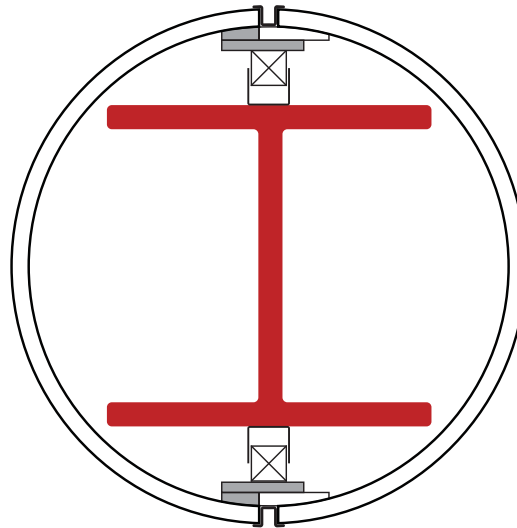
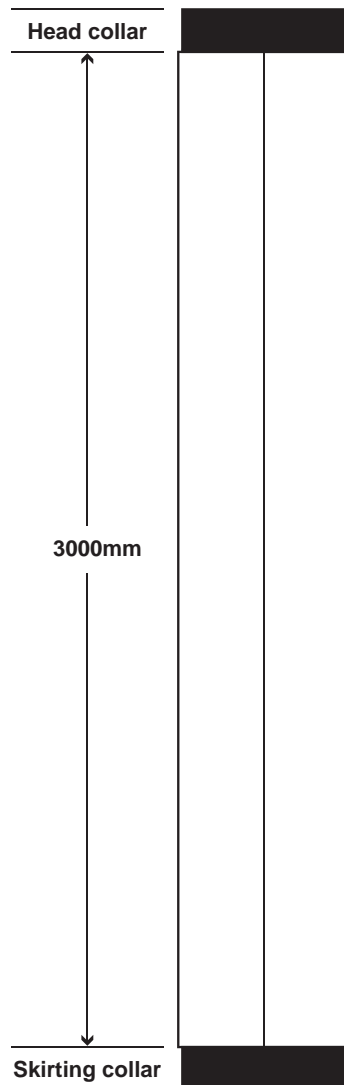

Standard Specification Details

Type: Pre-formed plywood column casings

Ref: Circa

Size: 12mm thick, diameters 250mm-1200mm

Standard Length: 3000mm

Finish: Plain, laminate or veneer

Joint Detail: Penny joint or feature extrusion

Accessories: Optional 200mm head and skirting collars plus support/fixing framework

Internal Diameter (mm)	External Diameter (mm)	Standard Length (mm)	Ex-stock Next Day Delivery
250	274	3000	*
300	324	3000	*
350	374	3000	*
400	424	3000	*
450	474	3000	*
500	524	3000	*
550	574	3000	
600	624	3000	*
750	774	3000	*
800	824	3000	
900	924	3000	
1000	1024	3000	
1200	1224	3000	

Circa column casings are manufactured in semi circles up to 600mm dia and as quarters from 750mm dia.

Extended circles can also be formed with the addition of flat insert panels to each side of the casing.

Circa

technical information

Manufacture

Heat and pressure are applied to bond layers of plywood veneers with a finishing kraft paper and compensating balancer to produce a strong and lightweight profile, which retains consistent shape with good rigidity and integral strength.

The manufacturing process ensures that a low moisture content of around 7% is maintained to provide greater stability.

To ensure an effective bond is achieved and the material retains high structural integrity, a type MR (moisture resistant) adhesive is used which conforms to British Standard 1204: 1979.

Alongside the standard plywood casings, we can also provide Circa products manufactured using veneers produced from sustainable timbers. For further information, please visit our website.

Installation

Circa casings are secured to structural columns using timber fixing battens and screws as shown on the typical installation diagrams.

Fixings are concealed by an extruded aluminium feature joint to create a 'shadow' gap. Alternatively, a 'penny joint' option is also available which can be filled on site and decorated to conceal the fixings.

Location

Circa pre-formed plywood casings are extremely versatile and are designed for interior use due to the nature of the materials and finishes used in their construction.

The immense scope of finishes available and the fact that they are durable, easy to install and cost effective, makes them one of the most popular column casing solutions.

Fire resistance and spread of flame

The substrate conforms to BS 476 part 7 class 2 spread of flame. When used in conjunction with a fire retardant laminate or lacquer, bonded with an appropriate adhesive system, conformance to class 1 spread of flame is achieved.

Two-year guarantee

All products in our Circa range carry a two-year guarantee, as standard. This covers the casings against de-lamination of the plywood veneers and bonded decorative finishes when used under normal conditions and is effective from the date of purchase.

Finish options

A range of finishes is available to meet individual specifications, including plain casings for on-site decoration together with high pressure laminates for increased durability and improved aesthetics. Please click [here](#) to go to the 'Finishes' section for more information.

Technical drawing downloads

A range of technical drawings in both PDF and DWG file formats are available from our website. Please click the image below to visit our download page and select the drawings you require.

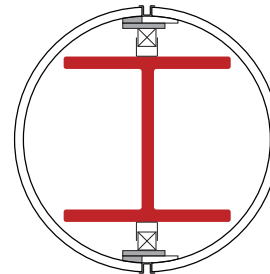

Quadra

plywood column casings

The n-case Quadra square and rectangular column casings maximise floor space by fitting closely to interior structural columns whilst allowing the maximum design flexibility in terms of size and finish options.

The range is available in standard sizes from 300mm to 1000mm and can be configured to meet precise project requirements. The versatility and design flexibility of Quadra column casings makes them suitable for use in a wide range of applications. They are already used in sectors such as education, retail, commercial and leisure.

Quadra column casings are available in a choice of standard white melamine, laminated or real wood veneer finishes.

Installation is also quick and simple. Quadra casings are a single fix dry trade solution which saves time on-site.

- * Maximises use of floor space
- * Cost effective method of covering structural columns
- * Range of standard and custom sizes available
- * Choice of melamine, laminated and veneer finishes
- * Quick and easy to install
- * Single fix dry trade solution

Click [here](#) for supply and install info.





Quadra

specifications and technical data

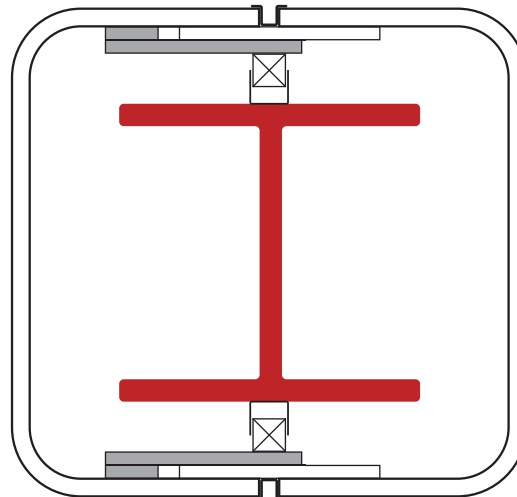
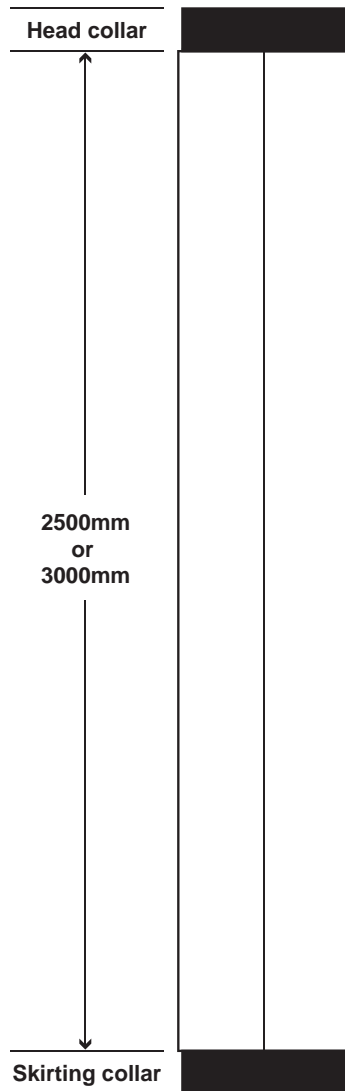

Standard Specification Details

Type: Pre-formed plywood column casings

Ref: Quadra

Size: 8mm thick, 300mm-1000mm

Standard Length: 2500mm or 3000mm

Finish: Melamine, laminate or veneer

Joint Detail: Feature extrusion

Accessories: Optional 200mm head and skirting collars plus support/fixing framework

Minimum Internal Size (mm)	External Size (mm)	Standard Length (mm)
252	300/300	2500/3000
302	350/350	2500/3000
352	400/400	2500/3000
402	450/450	2500/3000
452	500/500	2500/3000
502	550/550	2500/3000
552	600/600	2500/3000
602	650/650	2500/3000
652	700/700	2500/3000
702	750/750	2500/3000
752	800/800	2500/3000
802	850/850	2500/3000
852	900/900	2500/3000
902	950/950	2500/3000
952	1000/1000	2500/3000

n-case Quadra casings are available in a range of standard sizes and can be manufactured in square and rectangular shapes to meet precise installation and project requirements.

Quadra

technical information

Manufacture

Heat and pressure are applied to bond layers of plywood veneers with a finishing kraft paper and compensating balancer to produce a strong and lightweight profile, which retains consistent shape with good rigidity and integral strength.

The manufacturing process ensures that a low moisture content of around 7% is maintained to provide greater stability.

To ensure an effective bond is achieved and the material retains high structural integrity, a type MR (moisture resistant) adhesive is used which conforms to British Standard 1204: 1979.

Alongside the standard plywood casings, we can also provide Quadra products manufactured using veneers produced from sustainable timbers. For further information, please visit our website.

Installation

Quadra casings are secured to structural columns using timber fixing battens and screws as shown on the typical installation diagrams.

Fixings are concealed by an extruded aluminium feature joint to create a 'shadow' gap. Alternatively, a 'penny joint' option is also available which can be filled on site and decorated to conceal the fixings.

Location

Quadra pre-formed plywood casings are extremely versatile and are designed primarily for interior use due to the nature of the materials and finishes used in their construction.

The immense scope of finishes available and the fact that they are durable, easy to install and cost effective, makes them one of the most popular methods column casing solutions.

Fire resistance and spread of flame

The substrate conforms to BS 476 part 7 class 2 spread of flame. When used in conjunction with a fire retardant laminate or lacquer bonded with an appropriate adhesive system conformance to class 1 spread of flame is achieved.

Two-year guarantee

All products in our Quadra range carry a two-year guarantee, as standard. This covers the casings against de-lamination of the plywood veneers and bonded decorative finishes when used under normal conditions and is effective from the date of purchase.

Finish options

A range of finishes is available to meet individual specifications, including plain casings for on-site decoration together with high pressure laminates for increased durability and improved aesthetics. Please click [here](#) to go to the 'Finishes' section for more information.

Technical drawing downloads

A range of technical drawings in both PDF and DWG file formats are available from our website. Please click the image below to visit our download page and select the drawings you require.

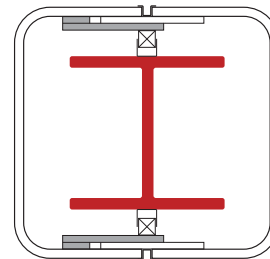

Forma

metal column casings

The n-case Forma range of metal column casings includes a wide range of shapes and incorporates circles, semi-circles, squares and rectangles.

Manufactured from aluminium, stainless steel and steel, Forma casings are available in thicknesses from 1.5mm to 3mm, depending on the profile and material selected and are ideally suited to interior and exterior applications covering all shapes in the range.

Produced using precision bending techniques in diameters from 250mm to 1000mm as standard, Forma casings are flexible enough to make installation a simple and straightforward process.

Individual Forma casings can be used on projects with heights of up to 4000mm, while multiple casings can be stacked to reach extended heights.

Forma casings allow complete freedom to explore design possibilities, yet enable you to also have total control of the materials, specifications, forms and finishes, giving you the ultimate in versatility, flexibility and choice.

- * Wide range of standard shapes & sizes
- * Suitable for interior and exterior applications
- * Exceptional choice of finishes for design flexibility
- * Up to 4000mm height in a single length
- * Easily stacked to reach extended heights

Click [here](#) for supply and install info.





Forma

specifications and technical data

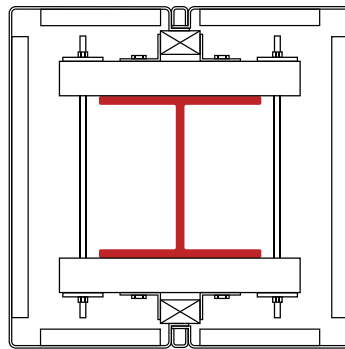
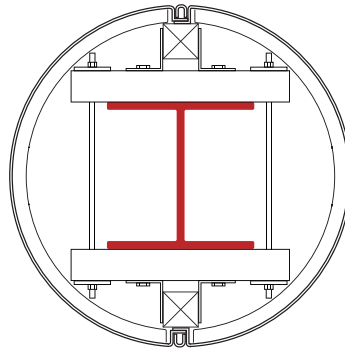
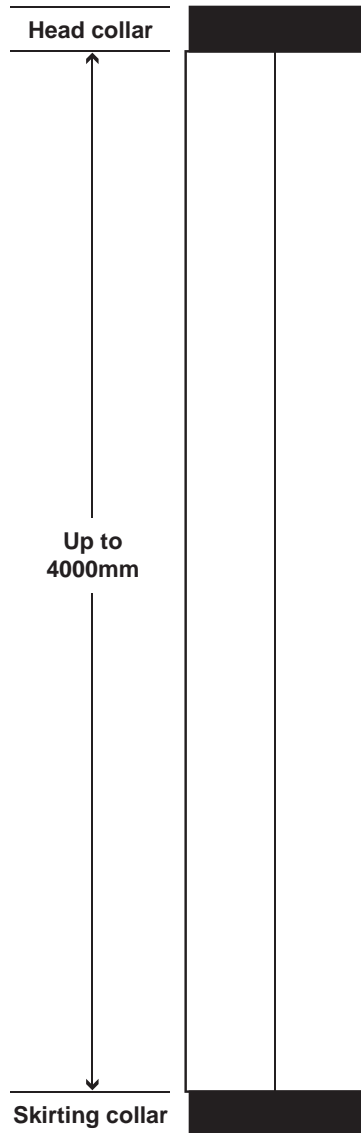

Standard Specification Details

Type: Aluminium, stainless steel or steel casings

Ref: Forma

Size: 1.5mm-3mm thick

Length: Up to 4000mm (refer to table)

Finish: Polished or polyester powder coated finish

Joint Detail: Infill feature extrusion

Accessories: Optional head and skirting collars.

Internal acoustic lining - 6mm or 20mm thick.

Internal Diameter (mm)	External Diameter (mm)	Length (mm)	Semi or Quarter Circles
246	250	up to 4000	Semi
296	300	up to 4000	Semi
346	350	up to 4000	Semi
396	400	up to 4000	Semi
446	450	up to 4000	Semi
496	500	up to 4000	Semi
546	550	up to 3000	Semi
596	600	up to 3000	Semi
646	650	up to 3000	Semi
696	700	up to 3000	Quarter
796	800	up to 3000	Quarter
896	900	up to 3000	Quarter
996	1000	up to 3000	Quarter

In addition to our standard sizes, custom sized circular, square and rectangular casings are also available in the range to meet specific project requirements.

Forma

technical information

Manufacture

Manufactured from aluminium, stainless steel or steel, which forms a 1.5mm or 3mm thick metal skin, the Forma range is designed for both interior and exterior use.

For additional support, a lightweight internal brace can also be supplied to give additional rigidity to the curved, square or rectangular sections.

The materials used in the Forma range conform to the following standards.

Aluminium – BS EN 485-2

Stainless steel – EN 10088-2 & BS EN 10259

Steel – BS EN 10051

Extruded products – BS EN 573 & BS EN 755

Fire performance

As Forma casings are manufactured from ferrous and non-ferrous metals, they can be regarded as non-combustible, achieving a Class 'O' spread of flame to BS 476-4.

Installation

A support frame is secured to the column, providing a rigid, lightweight and easy to fit structure to which the casing is secured using screw fixings.

All fixings are concealed using an extruded infill feature joint. This method is used as standard on all Forma column casings.

Location

Suitable for interior and exterior use, Forma casings are available in a range of shapes, including standard circular and square sections as well as custom shapes and dimensions to meet specific project requirements and installation needs.

Finish options

Polyester powder coatings and 'brushed' finishes are the most regularly specified, although a wide range of options is available. In addition to patterned, embossed and perforated materials, Forma casings can also be specified with anodised, oxide tinted or polished finishes depending on the material selected.

The finishes used with the Forma range conform to the following standards.

Polyester powder coating to BS 6496/7 in any RAL or BS 4800/381C colour.

Polishing – BS1134 Part 1 – Assessment of surface texture.

Anodising – BS 3987 (25 Microns).

Please click [here](#) to go to the 'Finishes' section for more information.

Technical drawing downloads

A range of technical drawings in both PDF and DWG file formats are available from our website. Please click the images below to go to our download page and select the drawings you require.

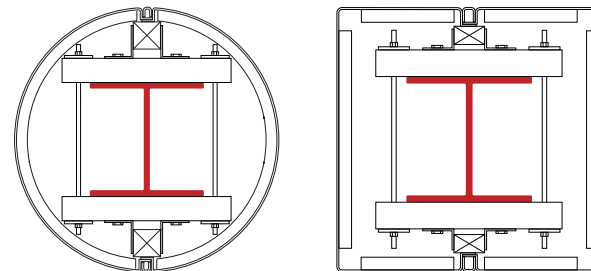

Polyma

grp column casings

The n-case Polyma GRP range is a highly versatility column casing solution that also provides outstanding performance and is easy to install.

Suitable for both interior and exterior applications, Polyma is a glass reinforced polymer casing solution, which possesses excellent resistance to weathering making it ideal for applications that are exposed to the elements. Also, its resilience and inherent resistance to scuffing, impact and other damage enables it to be used in high traffic environments.

A wide range of standard circular column casing sizes are available, but as Polyma casings are produced from a mould, this allows a high degree of versatility, enabling designers to specify custom shapes, sizes and surface finishes as well as a diverse range of RAL colours to meet the needs of specific projects.

As a result of this flexibility, n-case Polyma casings are already installed in a diverse range of sectors and applications, from offices, hotels and retail to health centres, care homes and education.

An integral brushed aluminium or stainless steel skirting collar option is available to give increased protection, durability and wear resistance.

- * Interior and exterior use
- * Wide range of standard and custom shapes & sizes
- * High resistance to impact, damage and scuffing
- * Easily stacked to reach extended heights
- * Wide range of RAL colours

Click [here](#) for supply and install info.





Polyma

specifications and technical data

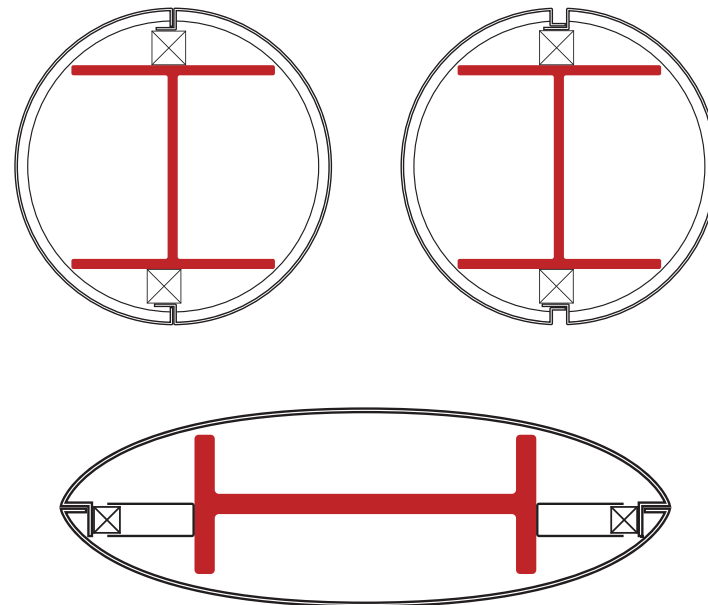
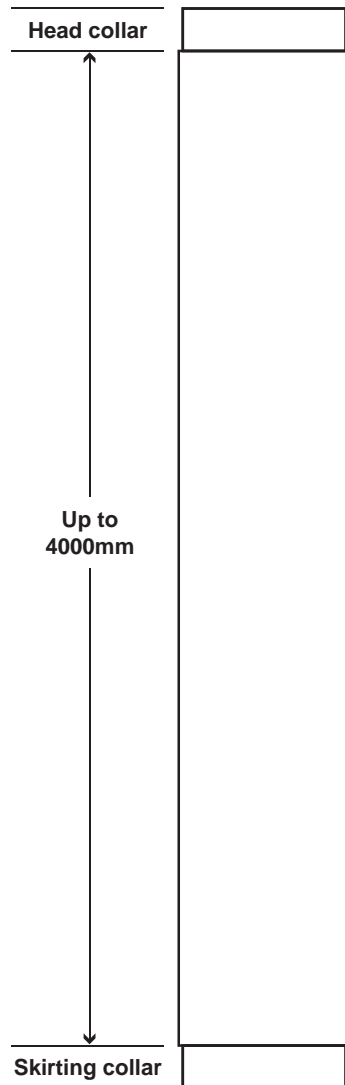

Standard Specification Details

Type: Glass reinforced polymer (GRP)

Ref: Polyma

Size: 4mm thick, diameters 250mm-1000mm

Length: Up to 4000mm (refer to table)

Finish: RAL or BS colour options

Joint Detail: Butt jointed or shadow gap

Accessories: Optional collar to the head or skirting

Internal Diameter (mm)	External Diameter (mm)	Length (mm)	Semi or Quarter Circles
250	258	4000	Semi
300	308	4000	Semi
350	358	4000	Semi
400	408	4000	Semi
450	458	4000	Semi
500	508	4000	Semi
550	558	3000	Semi
600	608	3000	Semi
650	658	3000	Semi
750	758	3000	Quarter
800	808	3000	Quarter
900	908	3000	Quarter
1000	1008	3000	Quarter

An integral brushed aluminum or stainless steel skirting collar option is available to give increased protection, durability and wear resistance.

In addition to our standard sizes, custom dimensions and shapes are also available following the production of a specific mould.

Polyma

technical information

Manufacture

n-case Polyma GRP casings are manufactured using 'hand lay-up' and 'spray lay-up' moulding techniques depending on the nature of the specification and the number of casings required.

A 'Gel-coat' is used within the moulding process to ensure a high quality finish is maintained on the outer surface.

The casings are produced by combining polymer resins with glass fibre strands or matting to build the material to the required thickness.

Typically, the columns have a ratio of glass fibre to resin of around 1:2.5, although the exact figure will vary depending upon the material thickness required and the individual specifications of the casings.

Standard shapes within the range include both circular and square sections. However, as Polyma casings are produced from moulds to meet individual specifications, virtually any custom shape or dimension can be produced.

Installation

Polyma circular and square casings are normally supplied as two separate 'halves', which are fixed to the structural columns with timber battens and joined with screw fixings to form a 'shadow gap'. Alternatively a butt joint can be achieved by using adhesives in place of mechanical fixings to join the casing.

Location

Polyma GRP casings can be used in both interior and exterior applications and possess excellent resistance to weathering.

Finish options

Polyma casings are produced to meet individual project specifications using RAL or BS coloured 'Gel-coat' finishes.

Extruded products – BS EN 573 & BS EN 755.

Technical drawing downloads

A range of technical drawings in both PDF and DWG file formats are available from our website. Please click the image below to visit our download page and select the drawings you require.

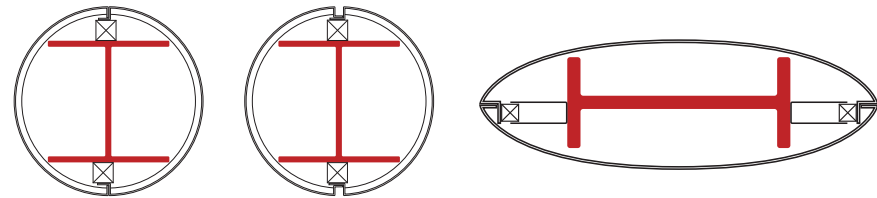

Gypra

grg column casings

n-case Gypra GRG column casings are designed solely for interior use and are manufactured from glass reinforced gypsum to provide an excellent blend of simple installation, strength and versatility as well as fire resistance.

Gypra casings are normally specified as circles although as they are produced from moulds, they can be manufactured to meet any individual specifications, including square and rectangular as well as virtually any custom shape.

Where a smooth finish is required for on-site painting, Gypra casings are an excellent solution, whether they are part of our standard range or custom made from a special mould to meet the specific needs of an individual project.

An integral brushed aluminium or stainless steel skirting collar option is available to give increased protection, durability and wear resistance. In addition, Gypra column casings are fire resistant, achieving a Class 'O' spread of flame, and can be regarded as a non-combustible building component.

- * For interior use only
- * Designed for on site finishing
- * Wide range of standard sizes
- * Special shapes and sizes available from dedicated moulds
- * Fire resistant – Class 'O' spread of flame

Click [here](#) for supply and install info.



Gypra

specifications and technical data

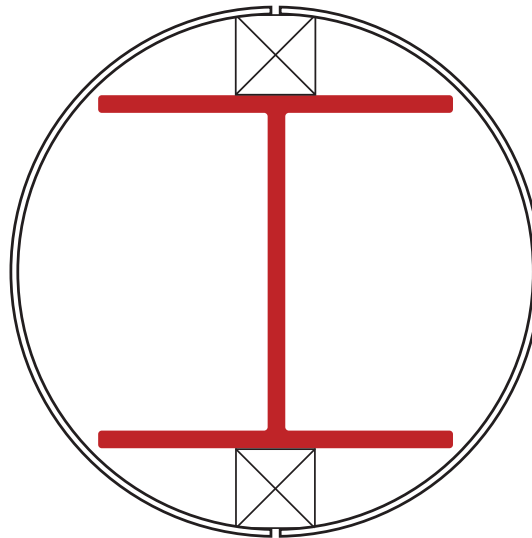
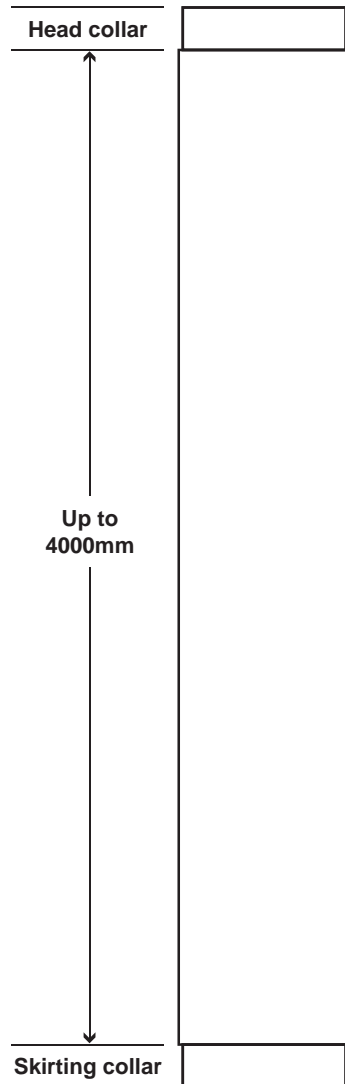

Standard Specification Details
 Type: Glass reinforced gypsum (GRG)
 Ref: Gypra
 Size: 4mm thick, diameters 250mm-1000mm
 Length: Up to 4000mm (refer to table)
 Finish: Plain for on site decoration
 Joint Detail: Penny jointed and filled
 Accessories: Optional collar to the head or skirting

Internal Diameter (mm)	External Diameter (mm)	Length (mm)	Semi or Quarter Circles
250	258	4000	Semi
300	308	4000	Semi
350	358	4000	Semi
400	408	4000	Semi
450	458	4000	Semi
500	508	4000	Semi
550	558	3000	Semi
600	608	3000	Semi
650	658	3000	Semi
750	758	3000	Quarter
800	808	3000	Quarter
900	908	3000	Quarter
1000	1008	3000	Quarter

An integral brushed aluminum or stainless steel skirting collar option is available to give increased protection, durability and wear resistance.

In addition to our standard sizes, custom dimensions and shapes are also available following the production of a specific mould.

Gypra

technical information

Manufacture

Gypra GRG casings are manufactured using moulding techniques, combining hard cast gypsum plaster with layers of pre-cut glass fibre reinforcement matting to create stable, rigid and self-supporting casings with a smooth surface finish suitable for on-site decoration.

Gypra casings are normally specified as circular casings although as they are produced from moulds, they can be manufactured to meet any individual specifications, including square and rectangular as well as virtually any custom shape, making them highly versatile.

Location

Gypra casings are designed for interior decorative use only and can be specified with a stainless steel or brushed aluminium skirting collar to give increased impact resistance and improved wear characteristics.

Installation

Gypra casings are normally supplied as two halves, which are fixed to structural columns with timber battens and secured with screw fixings.

A seamless finish is created with a 'penny-joint', which is then filled on site prior to painting and finishing.

Fire performance

Gypra column casings can be regarded as a non-combustible building component, achieving a Class 'O' spread of flame. Structural elements require additional protection from a proprietary fire protection system or intumescent coating.

Finish options

All Gypra casings are supplied unfinished, ready for painting or decoration on site.

Technical drawing downloads A range of technical drawings in both PDF and DWG file formats are available from our website. Please click the image below to visit our download page and select the drawings you require.

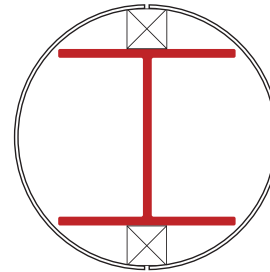

Metza

mezzanine floor column casings

The n-case Metza range is designed specifically for use with mezzanine floor installations to protect the supporting columns with a purpose designed fire resistant casing. Manufactured using an outer skin of coated steel, lined with dense fire resistant Rocksilk matting, Metza casings are extremely simple to fit and provide up to 3 hours fire protection.

Normally supplied as a four-sided casing, Metza comprises a 'U' shaped channel onto which the separate fourth side snaps and locks into place using an integral joint. Where access is restricted, Metza casings can also be supplied as two interlocking 'L' shaped profiles.

A range of finishes is available including PPC, PVC and PVF2 together with 'Plastisol' colour coats, galvanised steel and foodsafe white. All Metza casings are designed and manufactured to meet individual project specifications and environments, to ensure they comply with relevant legislation and provide effective fire protection.

Standard casings cover heights of up to 3650mm in a single length, although a dedicated jointing system is used to achieve extended heights.

- * Wide range of finishes for design flexibility
- * Up to three hours fire protection
- * Highly durable
- * Aesthetic finish
- * Quick and easy to install

Click [here](#) for supply and install info.



Metza

specifications and technical data

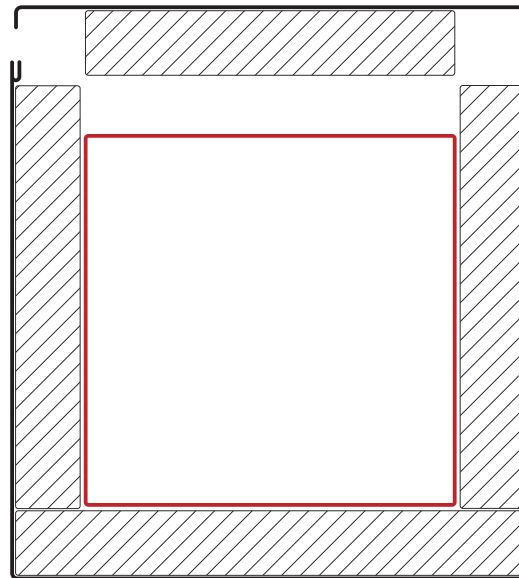
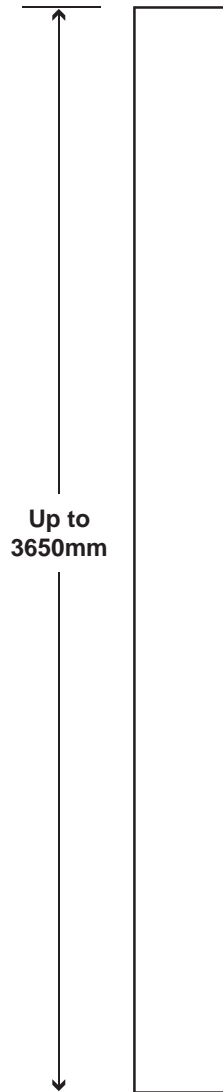

Standard Specification Details

Type: Mezzanine floor column casings

Ref: Metza

Size: 0.7mm thick

Standard Length: Up to 3650mm

Finish: PVC, PVF2, Plastisol, galvanised and
foodsafesafe white

Joint Detail: Snap lock joints

Fire rating: Up to 3 hours

Square Hollow Section Size (mm)	External Casing Size (mm)	Thickness (mm)	Standard Length (mm)
70/70	130/130	0.7	up to 3650
80/80	140/140	0.7	up to 3650
90/90	150/150	0.7	up to 3650
100/100	160/160	0.7	up to 3650
120/120	160/160	0.7	up to 3650
150/150	190/190	0.7	up to 3650

Metza

technical information

Manufacture

Metza column casings are designed specifically for use with interior mezzanine floor systems, primarily to protect the structural support columns from impact damage and fire.

Manufactured using an outer skin of coated steel, lined with a dense, fire resistant Rocksilks matting, Metza casings can provide up to 3 hours fire protection.

Installation

Normally supplied as a four-sided casing to fully encase the structural columns, Metza incorporates a 'U' shaped channel onto which the separate fourth side snaps and locks into place using an integral joint.

To simplify fitting when working close to walls or where access is restricted, the casings can also be specified as two interlocking 'L' shaped profiles.

Fire performance

Up to 3 hours fire protection is provided by Metza mezzanine floor casings as a result of the use of Rocksilks mineral wool fire barrier to encase the structural column inside a lightweight steel skin. The fire barrier is classified as non-combustible to BS 476-4 and Class 'O' spread of flame to the UK Building Regulations.

Finish options

A wide range of finishes is available for use in industrial warehousing, storage, office, retail and specialist food production environments. Please click [here](#) to go to the 'Finishes' section for more information.

Technical drawing downloads

A range of technical drawings in both PDF and DWG file formats are available from our website. Please click the image below to visit our download page and select the drawings you require.

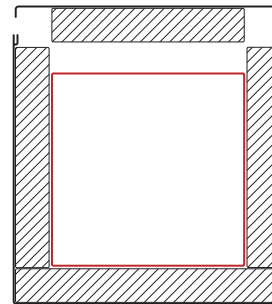

Fire protection

overview & considerations

While specific column casing products within the Encasement range are classified as achieving Class 'O' rating, in accordance with BS 476:Part 6 relating to fire propagation, they should be regarded as providing no fire protection to structural columns or components within a building.

With the exception of the Metza column casing range, separate structural fire protection systems should be specified and applied to comply with the UK Building Regulations approved Document B.

This ensures escape times are achieved and metal structures, beams & columns are not weakened under intense heat, as covered in the BS 476: Parts 20 & 21 standard, which is designed to protect the structure for a specified period of time, prior to reaching the recognised critical failure temperature of 550°C.

A number of different systems are available to achieve these standards, including fire rated insulation boards and concrete cladding as well as spray coatings and intumescent paints.

It is the responsibility of the specifier to ensure an appropriate system is used and applied correctly to meet the relevant standards and appropriate fire protection periods for each building design.

BS476 Parts 20 – 21 set out the key criteria for fire protection testing and the fire performance criteria are covered in detail in Building Regulations Part B (Appendix A).

Please note that none of the information above should be considered as recommendations or definitive guidance on structural fire protection.



Supply & install

a fully installed solution

Alongside our wide range of products and casing solutions, we also offer a supply and install service enabling us to maintain complete control over the project.

This service can be particularly useful for complex or larger projects or where the installation part of a particular contract falls outside of existing arrangements with specialist contractors.

Our installation packages can be undertaken as a complete 'stand alone' solution, requiring minimal intervention or co-ordination by the main contractor and can be delivered within a flexible schedule of work to integrate with the contract programme and handover.

All our site engineers and installation technicians are not only highly trained and experienced, but also comply with the necessary on-site safety and construction industry standards for risk assessment and skills certification.

As with all aspects of our business, we maintain high standards, professional working practices and competitive pricing. So if you require a supply only or supply and install service from Encasement, we've got it covered.

- * Flexible working to co-ordinate with main contractor's programme
- * Internal Quality and ITP systems to maintain high standards
- * All installation personnel are CSCS compliant
- * In house H & S consultant oversees safety requirements
- * Trained and skilled installers with more than 30 years of experience
- * Risk Assessments and Method Statements provided
- * Full O & M manual provided upon completion



Scope of Finishes

range guide



The choice of finishes within the n-case range provides a wide palette of textures and colours to meet most specifications and aesthetic requirements, while also integrating with interior and exterior building design.

Our column casing range encompasses a number of different materials, which also allows us to offer an exceptional range of finishes to meet specific aesthetic needs as well as individual project requirements, such as wear resistance and fire performance.

Within this guide, each product group has been identified separately and the corresponding finish options are listed within the selection table. The range is exceptionally wide, so for specific colours, applications or finish requirements, please contact our technical team on 01733 266 889.

To obtain further information on each of our individual finish ranges, please click on the relevant PDF download links under the table. If you would like to visit the individual manufacturers' websites, please click on the company logos to the right.

Finish type	Casing type	Circa	Quadra	Forma	Polyma	Gypra	Metza
Plain for on-site decoration		●			●	●	
Melamine white			●				
Laminated - plain		●	●				
Laminated - textured and wood grain		●	●				
Laminate - patterned		●	●				
Real wood veneers		●	●				
Galvanised steel				●			●
Stainless steel - brushed finish				●			
Stainless Steel - polished finish				●			
Aluminium - brushed finish				●			
Aluminium - anodised finish				●			
Coloured oxide tints				●			
Perforated patterns				●			
Embossed patterns				●			
PPC - RAL and BS colours				●	●		●
PVC coating - RAL & BS colours							●
PVF2 coating - RAL & BS colours							●
'Plastisol' coating - RAL & BS colours							●
Foodsafe white finish							●



- [Formica Laminate Plain Colours pdf](#)
- [Formica Laminate Woodgrain Colours pdf](#)
- [Polyrey Laminate Plain Colours pdf](#)
- [Polyrey Laminate Woodgrain Colours pdf](#)
- [RAL Paint Finish Colour Chart pdf](#)

en casement

our range includes...



boiler casings



pipe boxing



column casings



interior wall linings



retail interiors



furniture & display

For further information, click on the images above

Encasement Ltd
Peartree Business Centre
Enterprise Way
Bretton
Peterborough
Cambridgeshire
PE3 8YQ
t: +44(0)1733 266 889
f: +44(0)1733 268 999
e: sales@encasement.co.uk
www.encasement.co.uk

