



Axial fans

Warnings and instructions for use

Translation from the original language



Excerpt from the Declaration of Conformity



Ferrari Ventilatori Industriali S.p.A
36071 Arzignano (Vicenza)
Via Marchetti, 28
Tel. +39 0444 471100
Fax +39 0444 471105
<http://www.ferrariventilatori.it>

DECLARATION OF CONFORMITY

Pursuant to Annex IIA of Machinery Directive 2006/42/EC

The Manufacturer: Ferrari Ventilatori Industriali S.p.A.
Via Marchetti, 28
36071 Arzignano (VI) – Italy

DECLARES

under its own responsibility that **the machine denominated “industrial fan”**:



Main Index

1	INTRODUCTION	9
1.1	Purpose of this manual	9
1.2	Safety symbols used in this manual	9
1.3	Safety symbols used on fans	10
2	GENERAL INFORMATION	11
2.1	Definitions, basic principles, terminology used and correlated documents	11
2.2	Construction details of axial fans	12
2.2.1	Versions and motor positions	12
2.2.2	Flow indications	12
2.3	Fan identification	13
2.4	Description of fan	14
2.5	Envisaged use and foreseeable uses according to experience, and prohibited uses	15
2.6	Life cycle of fan	16
3	WARNINGS AND MAIN SAFETY INDICATIONS	17
3.1	Installation instructions: general information	17
3.2	Installation type A: Instructions for assembly, installation and connections	19
3.3	Installation type B: Instructions for assembly, installation and connections	22
3.4	Installation type C: Instructions for assembly, installation and connections	23
3.5	Assembly and fastener diagrams for fixing guards	24
3.6	Installation type D: Instructions for assembly, installation and connections	28
3.7	Risks involved in foreseeable incorrect handling and/or abnormal uses based on experience	29
3.8	Other risks related to fans pursuant to UNI EN ISO 12499	30
3.8.1	Specific risks with fans during installation	30
3.8.2	Specific risks with fans during maintenance	30
3.8.3	Environmental risks	31
3.8.4	Vibration risks	31
3.8.5	Operating speed risks	32
3.8.6	Noise emission risks	34
3.8.7	General information on noise emission data	36
4	TRANSPORT, MOVEMENT AND STORAGE	42
4.1	Lifting and movement	42
4.2	General warnings for lifting separate fan parts	42
4.3	Fan lifting instructions	43
4.3.1	Lifting version 1-9-12 axial fans	43



4.3.2	Lifting version 4 axial fans	45
4.3.3	Lifting version 8 axial fans	46
4.3.4	Lifting fans packed in crate	47
4.4	Storage	48
5	INSTALLATION	49
5.1	General information	49
5.1.1	Minimum installation distances	50
5.2	Assembly of axial fans	51
5.2.1	Version 4 axial fans	51
5.2.2	Version 1 axial fans	52
5.2.3	Version 9-12 axial fans	53
5.2.4	Version 8 axial fans	54
5.3	Installing and adjusting drive belts and final checks	55
5.4	Electrical connections	55
5.5	Connection to ducts	57
6	CHECKS TO BE MADE BEFORE AND AFTER STARTING	59
6.1	Preliminary checks	59
6.2	Checks to be made with fan fully operating	60
6.2.1	Visual checks on guards	60
6.2.2	Checking and cleaning parts in contact with fluids	61
6.2.3	Visual checks on impeller and casing	61
6.2.4	Dimensional checks	62
7	AXIAL FAN OPERATING MALFUNCTIONS	63
7.1	Most frequent malfunctions	63
8	MAINTENANCE	65
8.1	Bearing lubrication	66
8.2	Checking spherical roller bearings	69
8.3	Checking self-aligning ball bearings	70
8.4	Adjusting drive belt tension and cleaning belts	71
8.5	Flexible couplings	72
8.6	Filters and pressure gauges	74
8.7	Flexible anti-vibration joints between the fan and ducting	74
8.8	Checking and cleaning parts in contact with fluids	74
9	TECHNICAL CHARTS	75
9.1	ST supports versions A – AL – B - BL	75
9.2	Standard supports and bearings installed on fans with transmission	76

10	DISMANTLING AND REASSEMBLING ESSENTIAL COMPONENTS	77
10.1	Fan impellers with steel hub	77
10.1.1	Assembling impeller	77
10.1.2	Dismantling impeller	81
10.1.3	Adjusting blade angle	84
10.2	Fan impellers with aluminium hub	85
10.2.1	Assembling impeller	85
10.2.2	Dismantling impeller	89
10.2.3	Adjusting blade angle	90
10.3	Replacing drive belts	91
10.3.1	Assembling and dismantling pulleys	91
10.3.2	Assembling and dismantling drive belts	96
10.4	Replacing shaft and bearings on one-piece support	98
10.4.1	Dismantling shaft on one-piece support	98
10.4.2	Reassembling shaft on one-piece support	103
11	FINAL DISMANTLING AND DISPOSAL OF FANS	109
11.1	Version 4 axial fans	110
11.2	Version 1-9 axial fans	111
11.3	Version 12 axial fans	112
12	TECHNICAL APPENDICES	113
12.1	Tightening torques for nuts and bolts	113
12.2	Checklist before starting fans	115
12.3	Programmed maintenance intervals	116
12.4	Energy efficiency measurement system	117
13	INDEX	118



Index of Diagrams

Fig. 2-1 Axial fan versions	12
Fig. 2-2 Flow indications	12
Fig. 2-3 Identification plate of fan described by this manual	13
Fig. 2-4 Key to reading fan identification plate	13
Fig. 2-5 Example of version 9 with fan components indicated	14
Fig. 3-1 RC mesh guard	21
Fig. 3-2 RG mesh guard	21
Fig. 3-3 RS mesh guard	21
Fig. 3-4 RD mesh guard	21
Fig. 3-5 RE mesh guard	22
Fig. 3-6 RT mesh guard	22
Fig. 3-7 Assembly diagram for RC mesh	25
Fig. 3-8 Assembly diagram for RG mesh	25
Fig. 3-9 Assembly diagram for RS mesh	26
Fig. 3-10 Assembly diagram for RD mesh	26
Fig. 3-11 Assembly diagram for RE mesh	27
Fig. 3-12 Assembly diagram for RT mesh	27
Fig. 3-13 Positions of measurement microphones	37
Fig. 4-1 Example of lifting version 1 axial fans	43
Fig. 4-2 Example of lifting version 9 EF axial fans	44
Fig. 4-3 Example of lifting version 9 EB axial fans	44
Fig. 4-4 Example of lifting version 12 axial fans	44
Fig. 4-5 Example of lifting version 4 EF axial fans	45
Fig. 4-6 Example of lifting version 4 A ES axial fans	45
Fig. 4-7 Example of lifting version 4 B EF axial fans	46
Fig. 4-8 Example of lifting version 8 axial fans	46
Fig. 4-9 Example of lifting fans packed in crate	48
Fig. 5-1 Minimum installation distances with intake duct	50
Fig. 5-2 Minimum installation distances with free intake	51
Fig. 5-3 Assembly of version 4 axial fans	51
Fig. 5-4 Assembly of version 1 axial fans	52
Fig. 5-5 Assembly of version 9 and 12 axial fans	53
Fig. 5-6 Assembly of version 8 axial fans	54
Fig. 5-7 Diagram of electrical connections for one-speed and two-speed motors	56
Fig. 5-8 Example of positioning of external terminal box	57
Fig. 5-9 – Assembly tolerances for flexible joints	57
Fig. 5-10 Minimum installation distances with intake duct	58
Fig. 8-1 Checking radial clearance on bearings	69
Fig. 8-2 Axial movement s	70

Fig. 8-3 Checking drive belt tension	71
Fig. 8-4 Axial play	72
Fig. 8-5 Angular misalignment	72
Fig. 8-6 Parallel misalignment	72
Fig. 9-1 ST supports versions A – AL – B - BL	75
Fig. 10-1 Blade angle adjustment for impellers with steel hubs.	84
Fig. 10-2 Hub with extraction groove	85
Fig. 10-3 Hub with threaded extraction holes	85
Fig. 10-4 Locking blades	91
Fig. 10-5 Pulley holes	92
Fig. 10-6 Angular misalignment	94
Fig. 10-7 Parallel misalignment	94
Fig. 10-8 ST...A... one-piece support with radial ball bearings both on impeller side and transmission side	98
Fig. 10-9 ST...B... one-piece support with radial ball bearings on impeller side and roller bearings on transmission side	99
Fig. 10-10 Support with cooling fan	99
Fig. 11-1 Exploded view of version 4 fan	110
Fig. 11-2 Exploded view of version 9 fan	111
Fig. 11-3 Exploded view of version 12 fan	112



Index of Charts

Chart 3-1 Installation types supplied and mesh guards used	20
Chart 3-2 Fasteners fixing mesh guards	24
Chart 3-3 Acoustic power emitted Lw(A) (dBA)	38
Chart 3-4 Acoustic power emitted Lw(A) (dBA)	39
Chart 3-5 Acoustic pressure emitted Lp(A) (dBA)	40
Chart 3-6 Acoustic pressure emitted Lp(A) (dBA)	41
Chart 5-1 Sequence of operations for assembly of version 4 fans	52
Chart 5-2 Sequence of operations for assembly of version 1 fans	53
Chart 5-3 Sequence of operations for assembly of version 9-12 fans	54
Chart 5-4 Sequence of operations for assembly of version 8 fans	54
Chart 8-1 Quantity of grease for first filling of supports and bearings on fans with transmission	67
Chart 8-2 Relubrication intervals and quantity of grease according to fan rotation speed	68
Chart 8-3 Checking radial clearance on bearings	69
Chart 8-4 Tightening angle, axial movement and minimum residual clearance on ball bearings	70
Chart 8-5 Setting drive belt tension: test load and deflection	71
Chart 8-6 Technical characteristics of flexible couplings	73
Chart 9-1 ST supports versions A – AL – B - BL	75
Chart 9-2 Standard supports and bearings installed on belt-driven fans	76
Chart 10-1 Tightening torques	95
Chart 11-1 Component materials of axial impellers	110
Chart 12-1 Tightening torques M for bolts with ISO metric threads	113
Chart 12-2 Tightening torques for blade fixing bolts on fans with steel hub	114

1 INTRODUCTION



1.1 Purpose of this manual

This manual contains instructions and warnings, and constitutes documentation that must **compulsorily** accompany the product. Otherwise the product is lacking one of its essential safety requisites.

The manual must be kept with care, and must be made available to all persons involved with the product.

The warnings are intended to safeguard the safety of persons exposed to residual risks.

The instructions provide indications for the most appropriate conduct for the correct use of fans as intended by the manufacturer.

	<p>WARNING:</p> <p><i>The safety precautions used for the fan must also be adapted to its specific destination of use.</i></p>
	<p><i>The safety precautions differ according to the type of fan installation, as specified in paragraph 3.1 below.</i></p> <p><i>The information given in this manual is therefore indispensable for the use of fans in conformity with the destination of use of the product and without risks.</i></p>



	<p><i>In this manual the letters "FVI" stand for "Ferrari Ventilatori Industriali S.p.A."</i></p>
---	---

No part of this manual may be copied, reproduced or transmitted in any form whatsoever and by any electronic, mechanical or photographic means without the express authorization of **FVI**.

	<p><i>The FVI Technical Office is fully at your disposal for all information required.</i></p>
---	--





1.2 Safety symbols used in this manual

Certain items of particular interest in this manual may be preceded by one of the following symbols:

	<p>DANGER: <i>Indicates situations that might cause personal injuries.</i></p>
	<p>DANGER: <i>Live electrical components.</i></p>
	<p>WARNING: <i>Indicates important information of particular general interest</i></p>

1.3 Safety symbols used on fans

The following safety symbols are used on **FVI** fans:

	<p>Prohibited to lubricate and/or adjust moving parts.</p>
	<p>Prohibited to remove guards.</p>
	<p>Hazard due to presence of moving parts. This symbol is applied near the inspection hatches provided on fans. It is permitted to open inspection hatches only when all moving parts have reached a complete standstill.</p>
	<p>Indication of a lifting point. This symbol is applied near the points identified by FVI for lifting and moving the fan.</p>
	<p>Hot surfaces >60 °C. Danger of burns or scalding. Hot surfaces – Emission of hot fluids. This symbol is applied if the fan is used to move hot fluids.</p>

2 GENERAL INFORMATION

2.1 Definitions, basic principles, terminology used and correlated documents

- Point 3.1 of the UNI EN ISO 13349 standard defines a fan as “rotary-bladed machine which receives mechanical energy and utilizes it by means of one or more impellers fitted with blades to maintain a continuous flow of air or other gas passing through it and whose work per unit mass does not normally exceed 25 kJ/kg.”
- Point 3.6.1 of the UNI EN ISO 13349 standard defines an axial-flow fan as “a fan in which the air enters and leaves the impeller along essentially cylindrical surfaces with the fan.”
- The blades may have the following shapes: flat (obtained directly by pressing sheet steel) or more frequently a wing profile (obtained with diecast aluminium).

The fundamental dimensions that define a fan are as follows:

- Volumetric flow: this is the volume of fluid passing through the fan in a certain period of time — one second (m^3/s), one minute (m^3/min) or one hour (m^3/h);
- Static pressure: this is the energy imparted by the impeller to overcome the resistance offered by the system to the passage of fluid (measured in mm of water column = mm w.c. or Pascal = Pa);
- Dynamic pressure: this is the energy possessed by the fluid as a result of the speed imparted by the impeller at the output opening of the fan (measured in mm w.c. or Pa);
- Total pressure: this is the arithmetical total of static pressure and dynamic pressure (measured in mm w.c. or Pa);
- Flow: two directions for the fluid moved are identified for an axial fan, either from the motor towards the impeller (flow A) or from the impeller towards the motor (flow B), see Fig. 2-2;
- Rotation speed: this is the rotation speed of the impeller, and is measured in revolutions per minute (RPM);
- Efficiency: this is the percentage ratio between the energy that the fan manages to transmit to the fluid and the energy supplied by the motor to the impeller; it depends on impeller characteristics, and has no measurement units;
- Power absorbed: this is the power needed (provided by the motor) by the fan for correct operation, and is measured in kW;
- Identification plate motor power: this is the nominal power that the motor can provide; it must always be greater than the power absorbed by the fan, and is measured in kW;
- Acoustic pressure level: this is the energy propagated into the channel of the external ear and that generates vibrations of the ear drum, namely the level of noise emitted by the fan; it is measured in decibels using scale A (a scale that allows the impact of noise on the human ear to be assessed, according to the frequency of the noise);
- Acoustic power: this is the index of emission of acoustic power, and constitutes an intrinsic and constant characteristic of a sound source; it is expressed in watts.

The following documents are correlated to this manual:

- SCHAT01 Technical Information Sheet for the fan, which lists dimensions, weights, rotation speeds, fluid types, acoustic pressure and data on flexible couplings and vibration dampeners.
- CART01 Transmission Information Card, which indicates the characteristics of the transmission installed on the fan.
- The instruction and warnings manual of the manufacturer of the electric motor (if supplied together with the fan).

2.2 Construction details of axial fans

2.2.1 Versions and motor positions

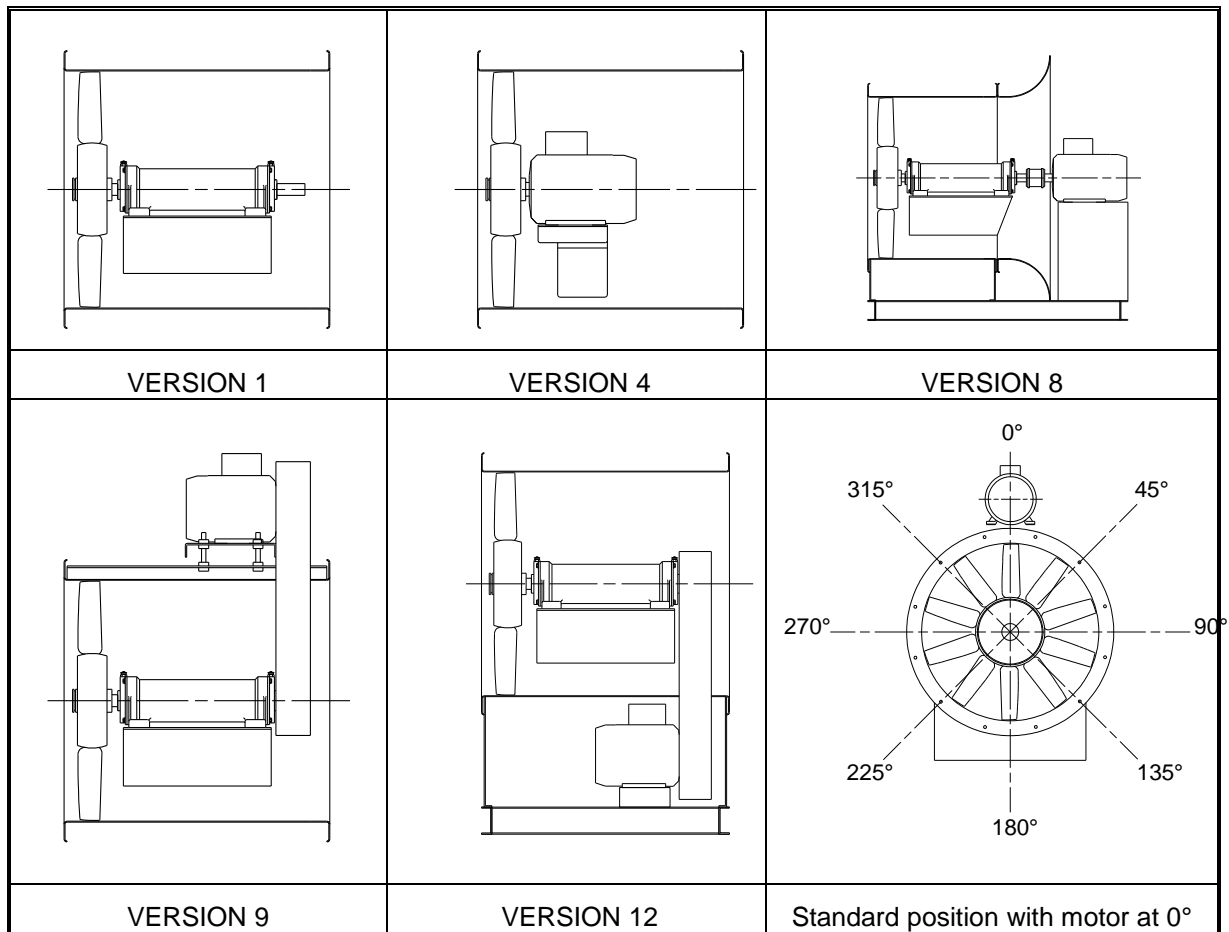

Fig. 2-1 Axial fan versions

2.2.2 Flow indications

The diagram refers to version 4, but is valid for all construction versions:

- A = Flow from motor to impeller
- B = Flow from impeller to motor
- U = Flow upwards
- D = Flow downwards

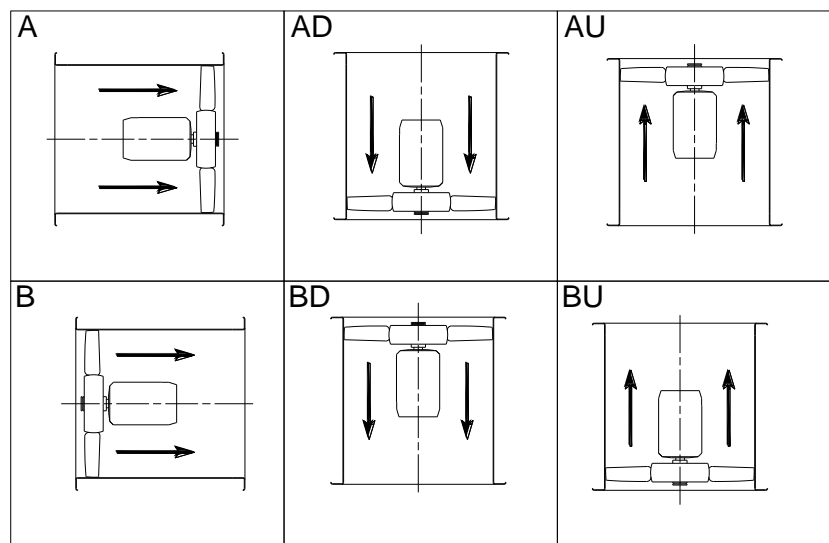

Fig. 2-2 Flow indications

2.3 Fan identification

The identification plate is the only means of fan identification recognized by the manufacturer. It must not be modified, and must not be removed or damaged. Fig. 2-3 shows the plate fitted to the fan.

FERRARI VENTILATORI INDUSTRIALI S.P.A. VIA MARCHETTI, 28-36071 ARZIGNANO (VICENZA) - ITALY T. +39 0444 471100 - F. +39 0444 471105 www.ferrariventilatori.com - info@ferrariventilatori.com		 MADE IN ITALY	
Tipo Type <input type="text"/>			
Codice Code <input type="text"/>		Matricola Serial Number <input type="text"/>	
Portata Volum. Flow Rate <input type="text"/> m ³ /s	Pressione Totale Total Pressure <input type="text"/> mm H ₂ O	Peso Weight <input type="text"/> kg	
Temp. Max Max Temp. <input type="text"/> °C	Vel. Max Max Speed <input type="text"/> r.p.m.	Anno di costr. Year of constr. <input type="text"/>	
Dati Motore Motor Data <input type="text"/>			Item <input type="text"/>
Cod. Cliente Customer Cod. <input type="text"/>		Comm. Job No. <input type="text"/>	
Grado di Efficienza al punto di efficienza ottimale Efficiency grade at optimum efficiency point		<input type="checkbox"/> N	Efficienza Efficiency <input type="text"/>
Grado di efficienza Efficiency grade <input type="checkbox"/> N	Categ. Misura/Efficienza Meas. /Efficiency Categ. <input type="text"/>	<input type="checkbox"/>	Inverter <input type="checkbox"/>

Fig. 2-3 Identification plate of fan described by this manual

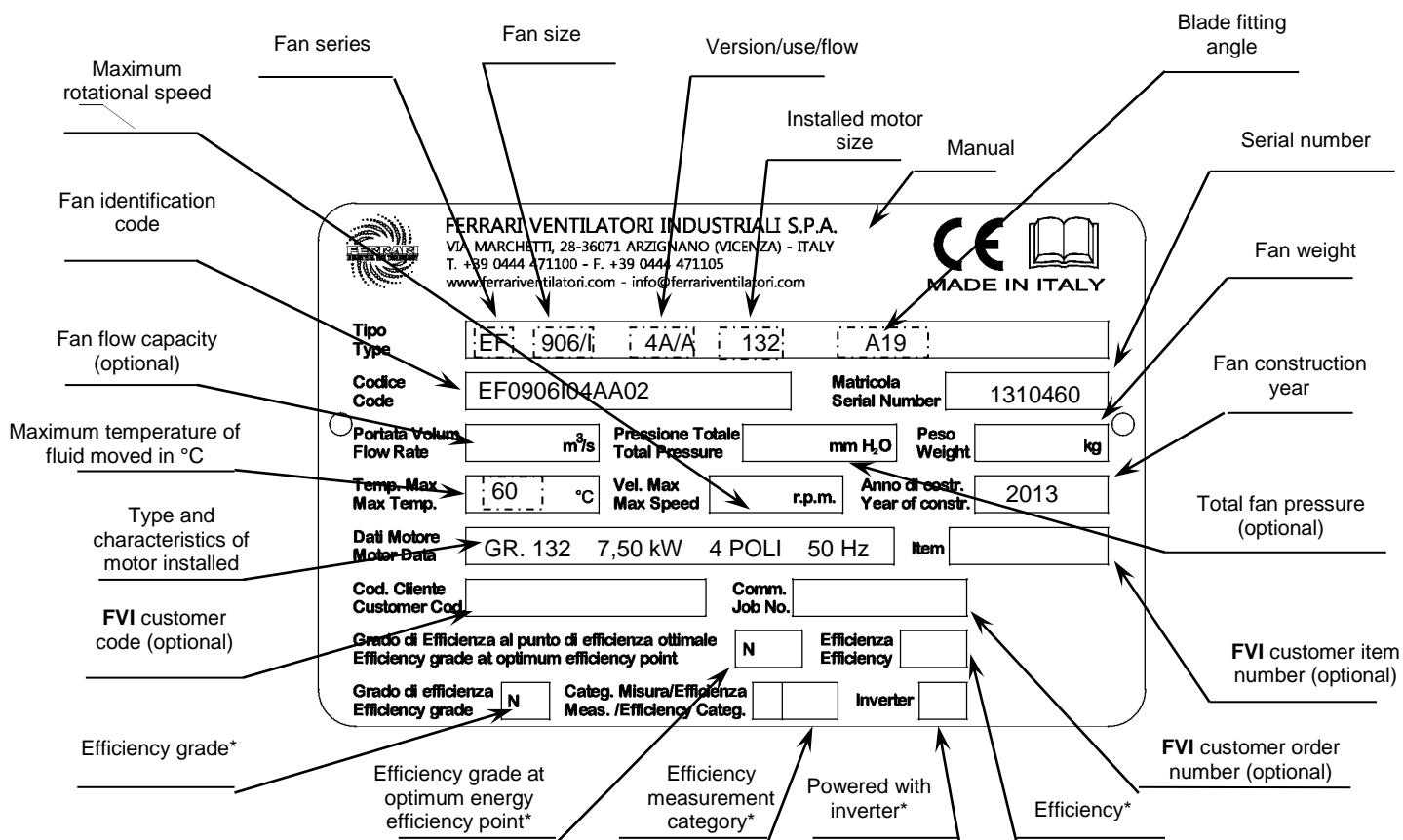

*In conformity with EU Regulation No. 327/2011

Fig. 2-4 Key to reading fan identification plate

2.4 Description of fan

Taking the fan shown in Fig. 2-5 as an example, an axial fan is generally constituted by the following components:

- an impeller that rotates to impart the necessary energy to the fluid (1);
- a casing housing the impeller, with a cylindrical shape (2);
- a motor support base with respective stays (3);
- guards to prevent accidental contact with all rotating parts (4);

The power that permits rotation of the impeller is provided therefore by a motor (5), usually but not exclusively electrically driven, linked to the impeller directly or by other organs of transmission, such as for example:

- a support complete with bearings and drive shaft (6);
- transmission by drive belts and trapezoidal pulleys (7) or flexible couplings to transfer the energy provided by the motor;
- a cooling fan between the impeller and the support, if the fluids are to be moved with an operating temperature greater than 60°C (8)

For versions 8 and 12 (see Fig. 2-1) a common base is normally provided to support the fan, the motor and the transmission.

Fans may be supplied with different construction characteristics that may also include other components not indicated in the above descriptions and that must be defined for each specific case. Fans may also be fitted with additional accessories (as shown on pages 187 to 204 of the “Axial Fan Catalogue”).

FVI fans are always supplied without control and monitoring systems.

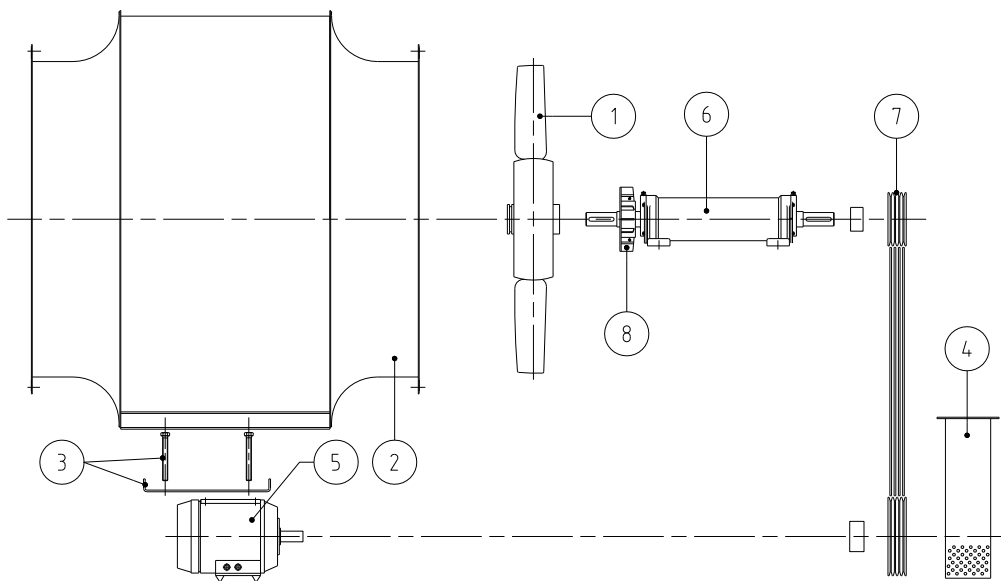

Fig. 2-5 Example of version 9 with fan components indicated

2.5 Envisaged use and foreseeable uses according to experience, and prohibited uses

The envisaged use for the fan with the identification plate as shown in Fig. 2-3 is as follows:

An industrial axial fan is a machine that serves to move a gaseous fluid inside a fluid movement system to which the fan is connected by means of ducts and technical chambers provided for this purpose. The flow of the fluid moved by the machine enters and leaves the fan in an axial direction.

The energy required to move the volumes of fluid entering the system from the suction intake is transferred by the rotation of the impeller inside the casing. Impeller rotation is obtained in most cases by the energy supplied by an electric motor, as indicated earlier in paragraph 2.4 of this manual.

The fan must be used in the flow range specified in the performance diagrams. Use of the fan with flows lower than the minimum value indicated in the diagrams may cause unstable fluid dynamic operation and vibrations.

Axial fans are used in many application associated prevalently with the development of industrial processes. Here is a list of some possible industrial sectors with application examples:

- Food processing sector (drying, cooking, circulation)
- Textile sector (air conditioning and treatment, drying)
- Steel sector (extraction of fumes)
- Brick products sector (extraction of fumes , drying)
- Woodworking sector (filtration, dust removal)
- Tobacco sector (conditioning, extraction of fumes)
- Paper sector (air conditioning and treatment, drying)
- Painting sector (filtration, dust removal)
- Transport sector such as maritime and railways (conditioning, motor cooling)
- Energy sector (turbine cooling, oil platform conditioning)
- Other applications not listed but agreed with our Engineering and/or Research & Development Area.

Some categories of use other than those described above are excluded, and more specifically:

- Operation of the fan with non-gaseous fluids or with fluids with characteristics different from those defined in the technical information sheet accompanying the fan, since structural damage may be caused to the fan with the possible risk of injury to persons and/or damage to things;
- Operation of the fan in all types of system with pressures (present or even partially generated by the fan) greater than 1.05 times standard atmospheric pressure, since structural damage may be caused to the fan with the possible risk of injury to persons and/or damage to things;
- Operation of the fan in all types of system classified in accordance with the ATEX 2014/34/EC Directive and that move potentially explosive fluids, since risks of ignition/explosion may occur with possible injury to persons and/or damage to things. Fans that are specifically constructed, classified and marked for ATEX conformity for a suitable category for the installation location are excluded, and these must be accompanied by the legally required documentation;
- Operation of the fan in industrial chemical plants where the fluid moved is highly corrosive for the materials used in fan construction, or in the presence of highly toxic fluids where the construction methods of casings and the types of seal used are not suitable for this specific application, since structural damage may be caused to the fan with the possible risk of injury to persons and/or damage to things;
- Operation of the fan in mining industry plants and with underground installations, since additional risks not considered in the use of the fan above ground may arise, with possible injury to persons and/or damage to things.



2.6 Life cycle of fan

The reliability of all components is guaranteed by a production process with ISO 9001 certification and by compliance with the programmed maintenance intervals indicated in paragraph 12.3 of this manual.

The components normally subject to wear are the following:

- bearings, calculated for a theoretical duration normally of 40,000 hours
- drive belts, calculated for a theoretical duration of 25,000 hours

For safety reasons, guards in electrowelded wire must be replaced every 2–3 years.

In the hypothesis of use of the fan at constant speed for two work shifts every day equivalent to 16 hours, calculated for 250 days per year, the expected life cycle for the impeller is equivalent to 40,000 hours.

In case of use in conditions of particularly difficult operation (medium, high), this limit must be reduced. Any such reduction must be assessed in collaboration with the **FVI** Technical Office. In the specific case of operation at variable speeds, the impeller life cycle must be assessed on a case-by-case basis, and must also be agreed with the **FVI** Technical Office.

	<p>CAUTION:</p> <ul style="list-style-type: none">• <i>Do not exceed the maximum rotation speed indicated by FVI.</i>• <i>Do not use ON-OFF operating cycles unless expressly approved by FVI.</i>• <i>Do not use variable-speed cycles unless expressly approved by FVI.</i>• <i>Do not subject the fan to thermal gradients greater than 3°C/minute.</i>
--	--

Even if it has never operated, an impeller that has been stored for more than ten years must be checked by **FVI** for possible defects before it can be used.

3 WARNINGS AND MAIN SAFETY INDICATIONS

3.1 Installation instructions: general information

	<p><i>Fans can be installed in four different ways, in conformity with the UNI EN ISO 13349 standard:</i></p> <ul style="list-style-type: none"> • <i>Type A: open intake and open exit;</i> • <i>Type B: open intake and exit connected to duct;</i> • <i>Type C: intake connected to duct and open exit;</i> • <i>Type D: intake and exit connected to ducts.</i>
---	---

Generally, FVI does not and cannot know which of the above installation types will be chosen and applied by the user, and unless otherwise specified by contract, the fan is supplied for installation types B, C or D, according to the fan series and flow (for a complete overview of installation types supplied see Chart 3-1). The person responsible for designing the system, together with the final user, must conduct an analysis of risks for the specific installation type chosen.

Depending on the way that it is intended to install and insert the fan in the fluid movement system, the following guards must be installed, according to installation type:

- Type A installation: fixed **FVI** guards installed on intake and exit;
- Type B installation: fixed **FVI** installed only on intake;
- Type C installation: fixed **FVI** guard installed only on exit;
- Type D installation: no fixed guards installed on intake and exit.

The system designer and the user must ensure that ducting systems are fitted with conformant guards for the duct connections made, as follows:

- Type A installation: no guards (no ducts are connected);
- Type B installation: fixed guard fitted on exit duct;
- Type C installation: fixed guard fitted on intake duct;
- Type D installation: fixed guards fitted both on intake and exit ducts.

	<p>CAUTION:</p> <p><i>Unless otherwise specified by contract, fans are supplied for installation types B, C or D in conformity with the UNI EN ISO 13349 standard and according to fan series and flow. Consult Chart 3-1.</i></p> <p><i>Always verify all safety aspects of the installation type chosen.</i></p>
---	---

	<p>CAUTION:</p> <p><i>Unless otherwise specified by contract, the fan and guards are suitable for installation as a single unit, and must not be subjected to effects of fluid dynamics caused by other machines installed in the same fluid movement system.</i></p>
---	--

With regard to guards to be fitted to ducts, in compliance with the design project, they must prevent access to parts of the fan and its accessories that could cause injuries. They must also be sufficiently robustly constructed to resist the stresses generated by the machine and environmental conditions.

FVI invites users and/or system designers to design, construct and install guards in conformity with the criteria of the UNI EN ISO 12499 standard.

	<p>CAUTION:</p> <p><i>Even with guards installed (regardless of the conditions of supply or installation), the fan may be dangerous due to the effects of indrawn or moved air.</i></p> <p><i>Depending on the dimensions of the fan, this type of danger may even CAUSE DEATH.</i></p> <p><i>The risk of being crushed against the intake grille may be fatal or may cause serious injuries (crushing of body parts, unconsciousness).</i></p>
---	---

	<p>CAUTION:</p> <p><i>It is advisable to adopt precautions that prevent access to the room containing the fan while it is operating, or to keep persons away with fixed guards that maintain a safe distance from the intake opening.</i></p> <p><i>For details consult the UNI EN ISO 13349 and UNI EN ISO 12499 standards.</i></p>
---	---

	<p>WARNING:</p> <p><i>Check the efficiency of all guards every month. In case of wear, damage or breakage, replace them immediately.</i></p>
---	---

Guards must be fixed securely in position using fixings that are not slackened by vibrations, and that require the use of a tool for their removal.

	<p>CAUTION:</p> <p><i>On starting and in compliance with programmed maintenance intervals, check that nuts and bolts are correctly tightened. Monitor vibration levels with a vibrometer, and establish an alarm threshold (see paragraph 12.3).</i></p>
---	---

It is always the responsibility of the installer to guarantee that there is an adequate level of protection against the risk of accidental contact with moving parts.

The installer and the user must also take other types of risk into consideration, and in particular those deriving from the entry of foreign bodies and the intake of explosive, inflammable or toxic gases or gases at a high temperature.

The risks involved in maintenance operations must also be taken into consideration. It must be possible to perform these operations in conditions of maximum safety, by isolating the fan from the motor or by taking other suitable precautions.

	<p>CAUTION:</p> <p><i>A safety procedure for access to the fan must be compiled, taking into consideration the indications provided by the manufacturer, information deriving from the analysis of risks at the installation point and safety requirements in workplaces.</i></p>
---	--

3.2 Installation type A: Instructions for assembly, installation and connections

In case of type A installations, since neither the intake nor exit of the fan are connected to ducts, guards must be fitted on both the intake and the exit.

Guard dimensions can be obtained from the dimensional drawing given in catalogues, from scale and non-scale drawing programs downloadable from the reserved area of the website, or from any dimensional drawings provided as documentation together with the products supplied.

	<p>CAUTION:</p> <p><i>Guards are designed to protect against accidental contacts and to resist the pressures generated only by the fan to which they are fitted.</i></p> <p><i>Each guard, if supplied individually, can be used only on the fan for which it was designed. If therefore a guard is ordered individually, it is compulsory to provide the reference details of the fan to which it will be fitted (serial number).</i></p>
---	---

Guards of the type shown in Chart 3-1 must be bolted to the fan intake and exit. Chart 3-1 also shows, highlighted with a grey background, the guards that depending on the installation type supplied constitute part of the fan itself.

Guard types are shown in Fig. 3.-1, Fig. 3-2, Fig. 3-3, Fig. 3-4, Fig. 3-5 and Fig. 3-6.

Fasteners for each type and size of guard are shown in Chart 3-2, and tightening torques in Chart 12-1.

Assembly diagrams for guards are shown in Fig. 3-7, Fig. 3-8, Fig. 3-9, Fig. 3-10, Fig. 3-11 and Fig. 3-12 respectively.

	<p><i>For flow definitions see Paragraph 2.1 Definitions, basic principles, terminology used and correlated documents.</i></p>
---	--

Series	Impeller hub material	Installation type supplied according to UNI EN ISO 13349	Flow	Intake guard (mesh)	Exit guard (mesh)
EF	aluminium	D	A	RC	RC
		D	B	RC	RC
ES	aluminium	B	A	RG	RC
		C	B	RC	RG
EB	aluminium	D	A	RC	RC
		D	B	RC	RC
EFR (version B)	aluminium	D	B	RC	RC
EK	aluminium	B	A	RE	RC
		C	B	RC	RE
EQ	aluminium	B	A	RD	RC
		C	B	RC	RD
EP	aluminium	B	A	RD	RC
		C	B	RC	RD
ET (version A)	aluminium	C	A	RG	RT
		B	B	RT	RG
EF	steel	D	A	RC	RC
		D	B	RC	RC
ES (version A)	steel	B	A	RS	RC
		C	B	RC	RS
EB	steel	D	A	RC	RC
		D	B	RC	RC
EFR (version B)	steel	D	B	RC	RC
AF	steel	D	A	RC	RC
		D	B	RC	RC

Chart 3-1 Installation types supplied and mesh guards used

(grey backgrounds show guards that depending on the installation type supplied constitute part of the fan itself)

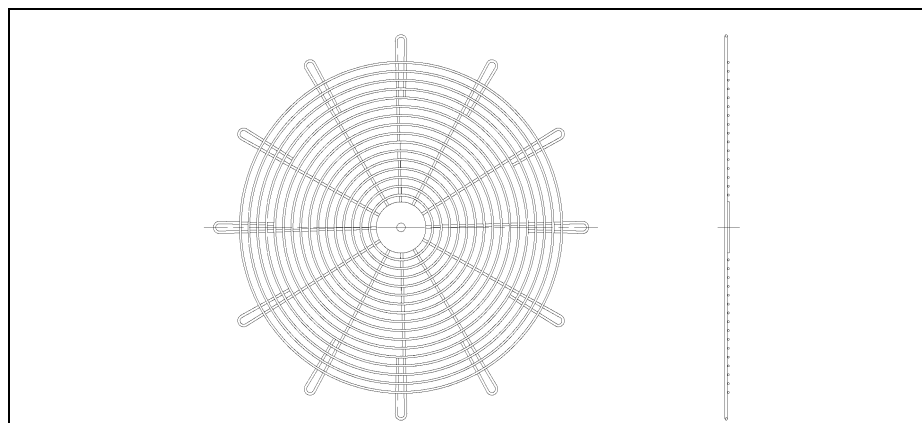

Fig. 3-1 RC mesh guard

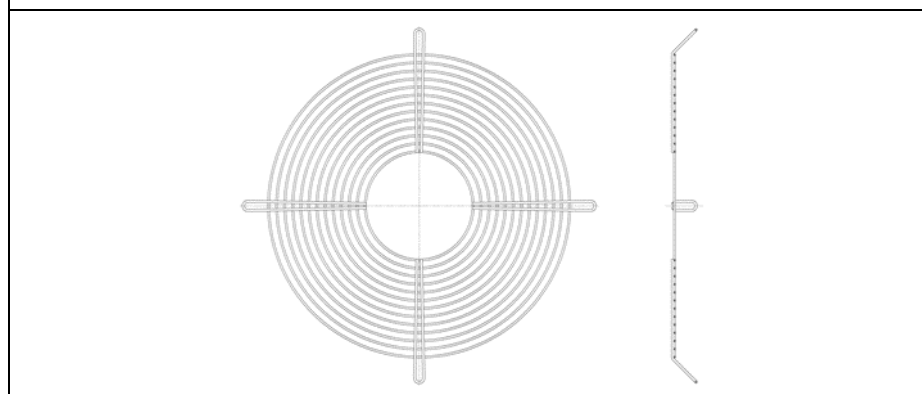

Fig. 3-2 RG mesh guard

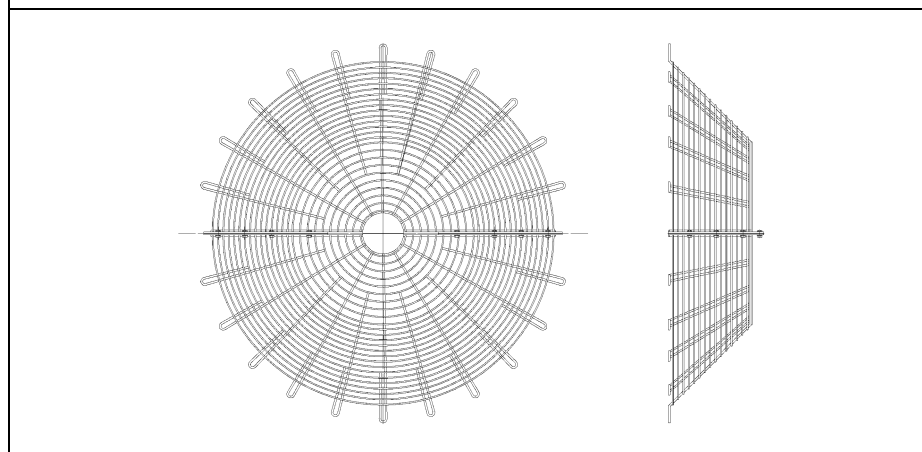

Fig. 3-3 RS mesh guard

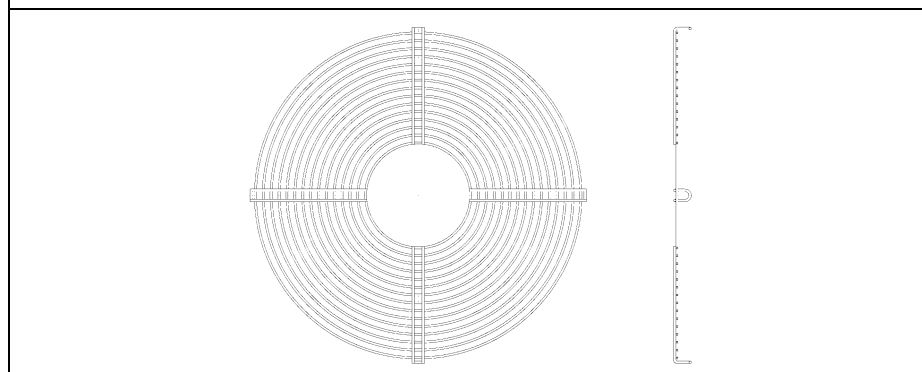

Fig. 3-4 RD mesh guard

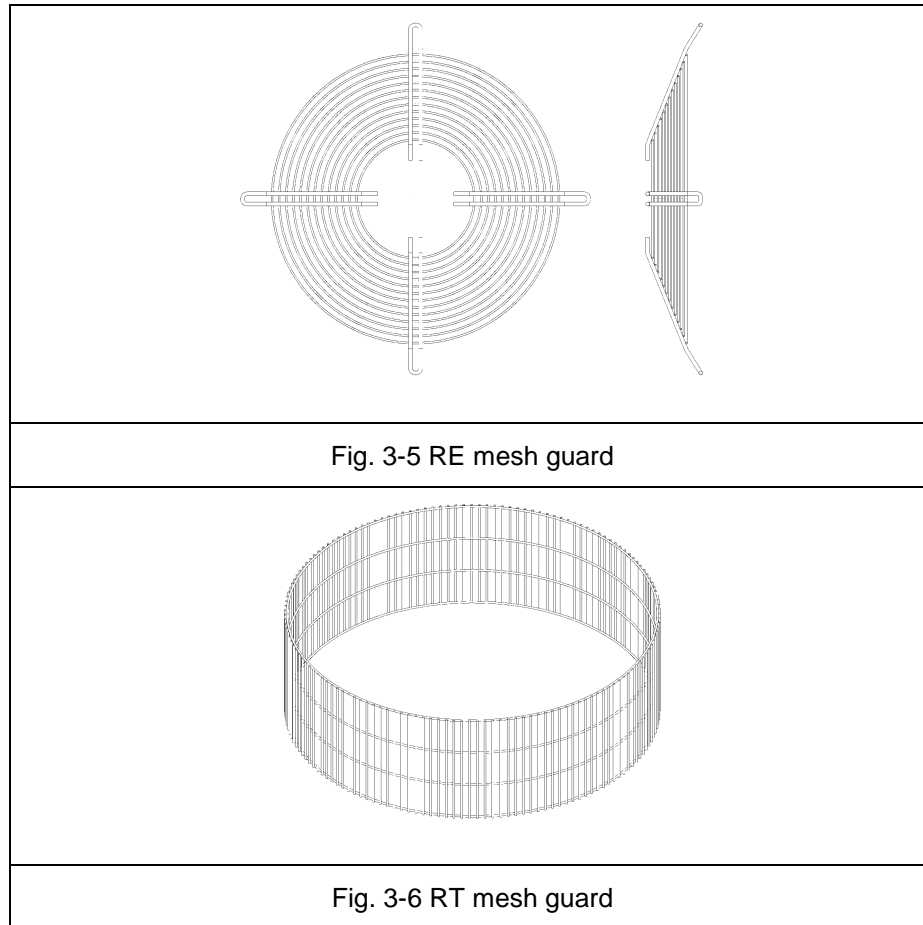

Fig. 3-5 RE mesh guard

Fig. 3-6 RT mesh guard

3.3 Installation type B: Instructions for assembly, installation and connections

In case of type B installations, since the fan intake is free and the exit is connected to a duct, a guard must be fitted on the intake.

Guard dimensions can be obtained from the dimensional drawings given in catalogues, from scale and non-scale drawing programs downloadable from the reserved area of the website, or from any dimensional drawings provided as documentation together with the products supplied.

	<p>CAUTION:</p> <p><i>Guards are designed to protect against accidental contacts and to resist the pressures generated only by the fan to which they are fitted.</i></p> <p><i>Each guard, if supplied individually, can be used only on the fan for which it was designed. If therefore a guard is ordered individually, it is compulsory to provide the reference details of the fan to which it will be fitted (serial number).</i></p>
--	---

A guard of the type shown in Chart 3-1 must be bolted to the fan intake. Chart 3-1 also shows, highlighted with a grey background, the guards that depending on the installation type supplied constitute part of the fan itself.

Guard types are shown in Fig. 3-1, Fig. 3-2, Fig. 3-3, Fig. 3-4, Fig. 3-5 and Fig. 3-6.

Fasteners for each type and size of guard are shown in Chart 3-2, and tightening torques in Chart 12-1.

Assembly diagrams for guards are shown in Fig. 3-7, Fig. 3-8, Fig. 3-9, Fig. 3-10, Fig. 3-11, Fig. 3-12 respectively.

3.4 Installation type C: Instructions for assembly, installation and connections

In case of type C installations, since the fan intake is connected to a duct and the exit is free, a guard must be fitted on the exit.

Guard dimensions can be obtained from the dimensional drawings given in catalogues, from scale and non-scale drawing programs downloadable from the reserved area of the website, or from any dimensional drawings provided as documentation together with the products supplied.

	<p>CAUTION:</p> <p><i>Guards are designed to protect against accidental contacts and to resist the pressures generated only by the fan to which they are fitted.</i></p> <p><i>Each guard, if supplied individually, can be used only on the fan for which it was designed. If therefore a guard is ordered individually, it is compulsory to provide the reference details of the fan to which it will be fitted (serial number).</i></p>
---	---

A guard of the type shown in Chart 3-1 must be bolted to the fan intake. Chart 3-1 also shows, highlighted with a grey background, the guards that depending on the installation type supplied constitute part of the fan itself.

Guard types are shown in Fig. 3-1, Fig. 3-2, Fig. 3-3, Fig. 3-4, Fig. 3-5, Fig. 3-6.

Fasteners for each type and size of guard are shown in Chart 3-2, and tightening torques in Chart 12-1.

Assembly diagrams for guards are shown in Fig. 3-7, Fig. 3-8, Fig. 3-9, Fig. 3-10, Fig. 3-11 and Fig. 3-12 respectively.



3.5 Assembly and fastener diagrams for fixing guards

According to fan size, guards are bolted onto the fan as shown in Fig. 3-7, Fig. 3-8, Fig. 3-9, Fig. 3-10, Fig. 3-11 and Fig. 3-12.

The fasteners necessary for assembly are shown in Chart 3-2.

Fan size	RC mesh	RG mesh	RS mesh	RE mesh	RD mesh	RT mesh
	Mesh fixing fasteners (no. x type)					No. pins
315	4xM8	4xM8	-	4xM8	4xM5	-
355	4xM8	4xM8	-	4xM8	4xM5	-
400	4xM8	4xM8	-	4xM8	4xM5	2
450	12xM8	4xM8	-	4xM8	4xM5	-
500	12xM8	4xM8	-	4xM8	4xM5	3
560	12xM8	4xM8	-	4xM8	4xM5	-
630	12xM8	4xM8	-	-	4xM5	3
710	16xM10	8xM10	-	-	8xM6	4
800	16xM10	8xM10	-	-	8xM6	4
900	16xM10	8xM10	22xM10	-	8xM6	5
1000	24xM10	8xM10	22xM10	-	8xM6	6
1120	24xM10	8xM10	30xM10	-	-	-
1250	24xM10	8xM10	30xM10	-	-	-
1400	30xM10	8xM10	30xM10	-	-	-
1600	30xM10	-	30xM10	-	-	-
1800	30xM10	-	30xM10	-	-	-
2000	30xM10	-	-	-	-	-

Chart 3-2 Fasteners fixing mesh guards

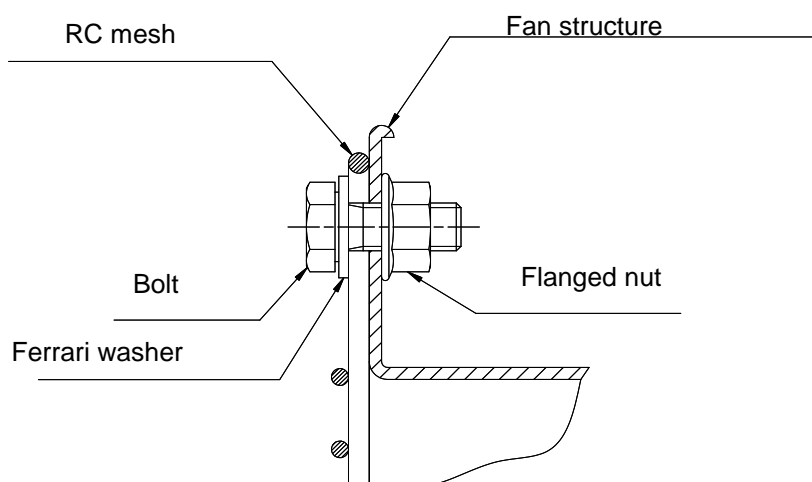

Fig. 3-7 Assembly diagram for RC mesh

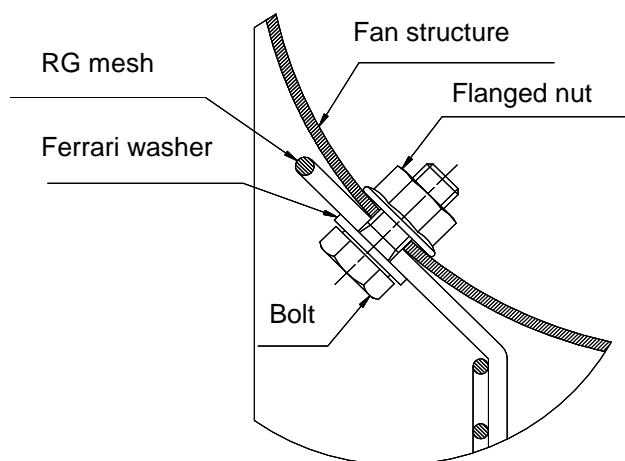

Fig. 3-8 Assembly diagram for RG mesh

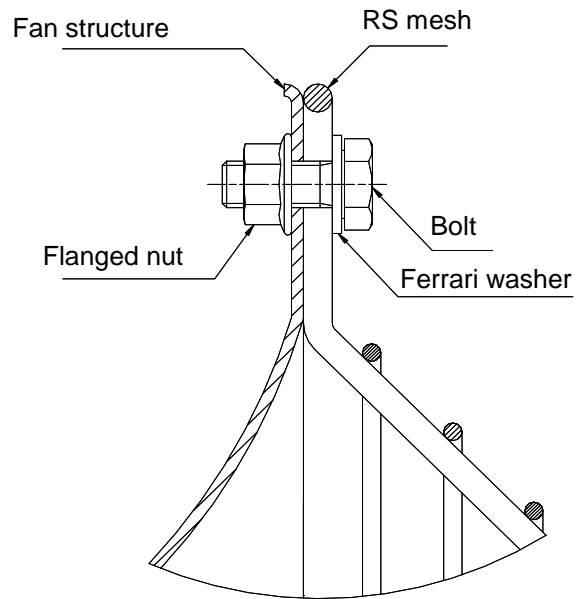

Fig. 3-9 Assembly diagram for RS mesh

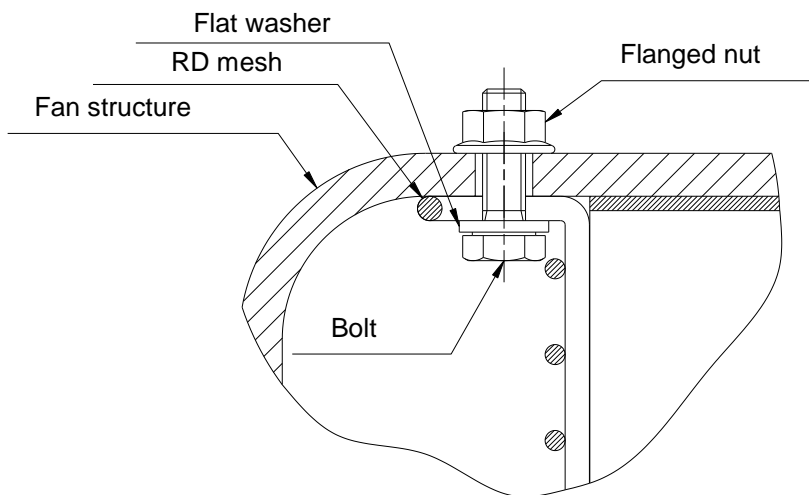

Fig. 3-10 Assembly diagram for RD mesh

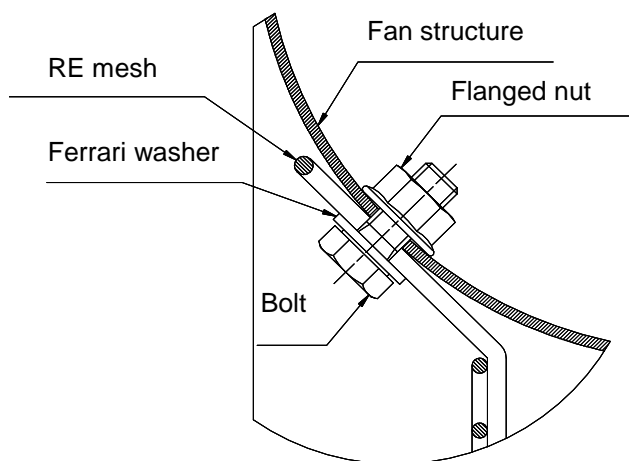

Fig. 3-11 Assembly diagram for RE mesh

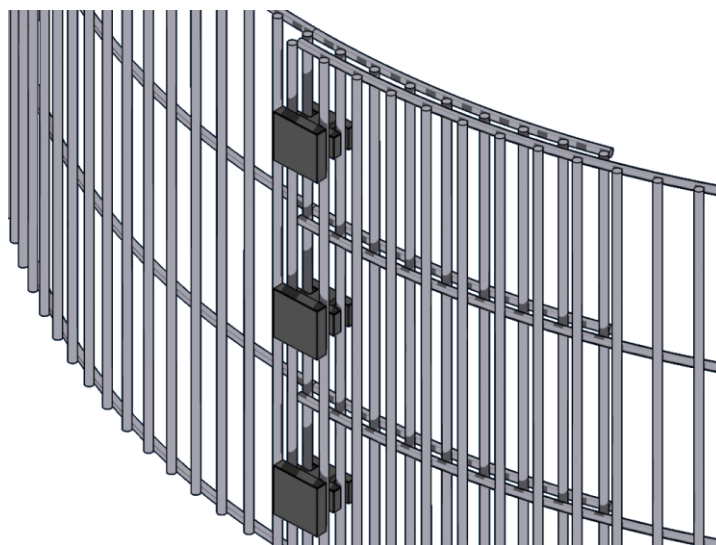

Fig. 3-12 Assembly diagram for RT mesh

3.6 Installation type D: Instructions for assembly, installation and connections

In case of type D installations, since both the fan intake and exit are connected to ducts, no guards need to be installed on either the intake or exit of the fan.

	<p>CAUTION:</p> <p><i>The system designer must assess the need to fit any necessary guards at the intake and exit ends of the system.</i></p>
--	--

	<p><i>For installation types B, C and D, it is advisable to insert an anti-vibration joint between the fan and ducts so as to compensate for any misalignments that may be present, to prevent the transmission of vibrations and to avoid structural stress.</i></p>
--	---

The choice of a standard anti-vibration joint for applications that are not particularly difficult depends on two fundamental factors:

- dust content of the fluid moved
- fluid temperature

Clean air	Type 2 joint < 60°C without anti-wear strip	Type 3 joint <180°C without anti-wear strip
Dusty air	Type 5 joint < 60°C with anti-wear strip	Type 6 joint <180°C anti-wear strip

Joints type 2, 3, 5 and 6 cannot be used on fans subject to the ATEX 2014/34/EC Directive.

	<p>CAUTION:</p> <p><i>Anti-vibration joints are suitable for installation on a single-stage fan, and must not be subjected to effects of fluid dynamics caused by other machines installed in the same fluid movement system.</i></p>
--	--

For special applications, such as for example the movement of fluids at a high temperature or that are particularly corrosive, or to guarantee perfect sealing of the joint, special joints must be used.



In this case the user and/or system designer must contact the **FVI** Technical Office.

3.7 Risks involved in foreseeable incorrect handling and/or abnormal uses based on experience

- When moving, lifting and installing the fan, always follow the instructions provided in this manual.
- It is absolutely prohibited to use the fan in conditions other than those indicated by the data on the identification plate.
- It is absolutely prohibited to deactivate, remove, modify or in any other way render inoperative safety devices, guards or control devices, either of individual components or of the fan itself.
- Do not position the hands, arms or any other part of the body near moving parts, even by forcing the opening of apertures.
- It is forbidden to extend parts of the body beyond protection structures. It is forbidden to use aids that may increase normal accessibility.
- It is forbidden to use fans in atmospheres or environments with the risk of explosions, with the exception of fans that are in conformity with the ATEX 2014/34/EC Directive.
- It is forbidden for unauthorized operators to work on any fan defects or malfunctions or to alter the type of operation or installation.
- Great care must be taken to ensure that fluids with characteristics other than those defined in this manual (technical information sheet) are not introduced into fans.
- After all repair work involving the removals of guards, barriers or other protection devices, these must be replaced and checked for correct positioning and efficiency before the fan is started again.
- All guards and safety devices must be maintained in conditions of perfect and constant efficiency. Warning signs, safety symbols and danger warnings must be also maintained in perfect efficiency and in their correct position.
- When tracing the causes of any faults or malfunctions with fans, take all the precautions described in this manual, intended to prevent all and any kind of injury to persons or damage to things.
- Remember to tighten all bolts, nuts and fixing rings on all mechanical components that are adjusted or serviced, following the indications given in Chart .
- Before starting the fan, check that all guards and safety devices are installed and in perfect operating condition. If they are not, it is absolutely prohibited to start the fan. The person responsible for plant safety or the department head must be informed immediately.
- Operators must be provided with Personal Protection Equipment (PPE) in conformity with legal requirements, such as for example safety footwear, a protective helmet (if suspended loads are to be moved), work gloves, insulated footwear and gloves (in case of work on electrical components) and all other items of PPE required by specific safety regulations. Bulky garments and various accessories (ties, wide sleeves, etc) are prohibited.
- The fluid moved by the fan must be adequately checked for the possible presence of toxic and/or inflammable substances, even if their presence is not envisaged in the use of the fan.

3.8 Other risks related to fans pursuant to UNI EN ISO 12499

The specific risks defined below are those deriving from mechanical aspects of the fan.



  	<p>A person may be injured as a result of:</p> <p>a) <i>being dragged between a moving part and a fixed part, for example a impeller and the casing or some other fixed part of the fan;</i></p> <p>b) <i>being dragged between two moving parts, for example a drive belt and a pulley;</i></p> <p>c) <i>being dragged into the fan through the air intake, with consequent contact with the shaft or impeller;</i></p> <p>d) <i>contact with a moving part, such as the impeller;</i></p> <p>e) <i>ejection from the fan exit of fragments deriving from the introduction of residual solids or liquids extraneous to the process, or deriving from the suction environment;</i></p> <p>f) <i>an object drawn into the fan mouth and ejected at high speed from the fan intake or exit;</i></p> <p>g) <i>structural defects of fan components;</i></p> <p>h) <i>contact with fan surfaces at dangerous temperatures, for example below -20°C or higher than +50°C;</i></p> <p>i) <i>when working with hot fluids, there may be losses of jets of hot fluid from the transmission shaft hole that may cause burns or scalds.</i></p> <p>l) <i>the potential harmfulness of the fluid being moved or the presence of substances that in case of leaks may be hazardous;</i></p> <p>m) <i>a hazard deriving from motor overspeed, which may cause the breakage of machine parts;</i></p> <p>n) <i>the intake of air at abnormal temperatures higher than those recommended may cause structural deformations, malfunctions and hazards.</i></p>
---	---

3.8.1 Specific risks with fans during installation

- The user must provide a well-levelled fixing surface. Incorrect levelling may cause abnormal fan vibrations that over time could cause deformation and/or breakage, with the detachment of fan parts, representing a hazard for exposed persons that may even be fatal.
- The user must also arrange electrical connections for the fan casing or structure to the main electrical grounding system of the place of use, to prevent any formation and accumulation of static electricity.
- All guards installed must remain correctly connected to the fan with all relative fasteners (bolts, nuts, etc). The removal of one or more fixing points may impair the functionality and solid fixing of the guard.
- Fans supplied as standard versions **are not** intended for use in potentially explosive environments.
- The place of installation of the fan must be kept clean. Any spills of oil or water not due to the fan must be cleaned away as quickly as possible.
- The minimum installation distances defined in this manual must always be respected to guarantee correct operation and the absence of additional risks. Incorrect positioning could impair the correct operation of the fan.

3.8.2 Specific risks with fans during maintenance

- During maintenance and cleaning operations on the impeller, take great care with rotations of the impeller, which could cause trapping or cutting injuries against fixed parts of the casing.
- A programmed maintenance schedule for the fan must be prepared and applied, so as to prevent mechanical failures or breakages caused by wear or inadequate maintenance (see paragraph 12.3).

	<p>CAUTION: IT IS ABSOLUTELY PROHIBITED TO:</p> <ul style="list-style-type: none"> • Carry out any type of maintenance operation without having first checked that the fan impeller is effectively at a standstill. • Proceed with any type of maintenance operation on the fan (including lubrication) without having first disconnected it from the mains powers supply. • Clean the fan while it is operating. • Open fan guards or inspection hatches while it is operating.
	<p>CAUTION:</p> <p><i>Even when the power supply to a fan is interrupted, its rotating parts may still move, due to air passing through the fan, either naturally or from fluid currents generated by a fan located in other parts of the system of linked ducts, or due to the inertia of the impeller after the machine has been switched off. In this case as well, there may be the risk of trapping or cutting injuries against fixed parts of the casing.</i></p>

3.8.3 Environmental risks

FVI fans are designed to operate in and to withstand ordinary conditions of working environments.

The presence of:

- vibrations
- Corrosive agents (dust, gas, fumes, mist)
- high temperatures
- condensation
- solid bodies
- abnormal turbulence
- currents of air
- voltage differences due to installation

can affect the lifespan of components, causing premature deterioration, above all with respect to guards.

Since it is impossible to establish all-inclusive criteria that can take into account all the possible combinations of these effects, it is advisable to implement a plan of periodical checks according to the effective deterioration noted, so that any variations in structural characteristics can be detected in subsequent checks.

3.8.4 Vibration risks

Vibrations are the main factor affecting the operational life and safety of fans, and for this reason it is essential to accurately monitor their level during fan operation and work cycles.

The ISO 1940/1 and ISO 2372 international standards establish the field of acceptability and the classification of rotating machines, and more specifically, the ISO 14694 standard establishes values for industrial fans.

The reference values for FVI products are established by category BV3 of this standard.

	<p>CAUTION:</p> <p><i>Failure to check vibration levels may generate high risk factors and compromise the operative lifespan of the fan.</i></p>
---	---

If ignored, vibrations can:

- cause the formation of cracks serious enough to cause structural failure, which may even be sudden
- cause difficult operating conditions for bearings, with malfunctions that may even include seizing (with dangerous overheating effects)
- cause slackening of tightening and fixing components (nuts and bolts)
- generate greater noise.

FVI strongly recommends the use of a control and monitoring system for the fan, with continuous monitoring of vibrations and bearing temperatures.

Depending on the specific application and use of the fan, it is advisable to define an "alarm threshold" for fan vibration levels and bearing operating temperatures.

	<p><i>The monitoring of vibrations and temperatures makes it easier to take preventive actions against accidents.</i></p>
--	---

3.8.5 Operating speed risks

Operating speeds greater than those envisaged by the fan design can create conditions of risk due to the reduction of the operative lifespan of moving parts.

In case of faults or malfunctions, overspeed conditions may be created due to:

- Errors in the control logic system
- Short circuits on monitoring components
- Driver or inverter malfunctions
- Mechanical breakage of components, and in particular on encoder shafts.

	<p>CAUTION:</p> <ul style="list-style-type: none"> • <i>Do not exceed the maximum rotation speed indicated by FVI.</i> • <i>Do not use ON-OFF operating cycles unless expressly approved by FVI.</i> • <i>Do not use variable-speed cycles unless expressly approved by FVI.</i> • <i>Do not subject the fan to thermal gradients greater than 3°C/minute.</i>
--	---

	<p>CAUTION:</p> <p><i>A condition of overspeed, even for a limited time, may cause irreversible damage and create situations of extreme risk hazards.</i></p>
--	--

During normal operation, conditions of overspeed attributable to the drive system or motor may occur, in particular if the fan is supplied "with shaft only" or with motor "without drive system".

In these cases, it is the responsibility of the user to verify and guarantee the correctness of additional installations.

The construction of the transmission by the user or installer is a critical point for safety.

The transmission is an integral part of the machine, and its construction requires a design process and awareness of the design parameters developed by **FVI**.

	<p>CAUTION:</p> <p><i>To construct the entire transmission and/or install the motor only, the user and/or installer must always request the transmission specifications document. It is absolutely prohibited to construct transmissions with the use of couplings, drive belts and pulleys of types other than those indicated by the transmission specifications document.</i></p>
---	---

	<p>CAUTION:</p> <p><i>If no inverter is used for gradual starting of the fan, it is absolutely prohibited to use toothed pulleys, as these can cause irreversible damage to fan structures. Consult the FVI Technical Office.</i></p>
---	---

	<p>CAUTION:</p> <p><i>Conditions of overspeed can be caused by drive system faults on fans with direct transmissions.</i></p>
---	--

In the case of directly-coupled fans of high power, starting is a moment of particular stress for rotating mechanical organs.

	<p>CAUTION:</p> <p><i>Above 11 kW, a gradual starting procedure must be used, to avoid overloading the transmission system and the impeller, with the consequent risk of breakages in these components.</i></p>
---	--

In the case of fans supplied without an electric motor, incorrect electrical connections to the motor or the wrong motor choice could be the cause of operation at speeds in excess of the original design speed, given that the rotation speed of an asynchronous motor depends on the frequency and the number of poles.

	<p>CAUTION:</p> <p><i>Fans are designed to be powered with a supply frequency of 50 Hz.</i></p> <p><i>The manufacturer must always be contacted in the case of use of a supply frequency other than the original design frequency. Do not proceed until authorized.</i></p>
---	--

The use of a supply frequency different from the original design frequency affects all fan characteristics. The modification of conditions of use requires a complete revision of the technical information sheet of the fan.

In the case of use at varying fan speeds or with frequent starting and stopping during operation, rotating organs are subject to mechanical stresses that may affect their operative lifespan.

	<p>CAUTION:</p> <p><i>In the case of fan operation with a variable speed cycle of less than 30 minutes, this cycle must be submitted to approval by the FVI Technical Office, which will give its approval and notify the consequent reduction of maintenance intervals and the fan lifespan.</i></p>
---	---

	<p>CAUTION:</p> <p><i>Fan operation within a very broad range of operating speeds may lead to increased vibration in correspondence with a specific resonance frequency of the system of which the fan is only a single component.</i></p> <p><i>Avoid working at speeds coinciding with structural resonance frequencies, and if this is not possible, modify some variable that can change the resonance frequency of the system, for example by using vibration dampers of a different type.</i></p>
---	--

If the rotation direction of a fan must be inverted, or if it must be restarted, this must be done only when the impeller is in the rest position (total standstill).

	<p>CAUTION:</p> <p><i>Inverting the fan rotation direction or starting it with the impeller turning in the opposite direction may cause breakage of the blades and/or the impeller hub, with the risk of ejection of metal parts.</i></p>
---	--

The replacement of moving parts with non-original spare parts may be the cause of different operating conditions with respect to the original design condition (e.g. AISI 304 stainless steel, AISI 316L stainless steel or Corten).

	<p>CAUTION:</p> <p><i>Respect the maximum speeds indicated in the catalogue for the applicable temperature. For transmission shafts in stainless steel, these speeds must be reduced by 20%. Comply with the information given on the transmission specifications document supplied with the fan.</i></p>
---	--

Operation at a speed significantly lower than up to 40% of nominal speed (unless otherwise specified by **FVI**) may affect the cooling of the motor and bearings, with possible malfunctions due to higher temperatures. For electrical components, the user and installer are advised to provide adequate protection for the drive system or motor, with the use of heat detection capsules if possible, and also using a servo-ventilated motor if necessary.

Resonance phenomena in the structure must be avoided. These may emerge at specific rotation speeds, and may cause damage to the structure.

	<p>CAUTION:</p> <p><i>Resonance phenomena at low frequencies may cause damage to the structure.</i></p>
---	--

3.8.6 Noise emission risks

FVI designs its fans dedicating attention to the elimination of the noise that they generate. Nevertheless, during normal operation fans act as a sound source.

The spectrum of frequencies of acoustic emission depends on the dimensional and structural characteristics of the fan, and also on its application of use (rotation speed, fluid moved, etc).

FVI, in collaboration with TUV, has measured the acoustic emissions of its fans in its own test laboratory in accordance with the EN ISO 3744 – EN ISO 3746 – ISO 13347 standards.

Tests were conducted with fans similar to those to which this manual refers, and relative values of acoustic power and pressure are shown in Chart 3-3, Chart 3-4, Chart 3-5, and Chart 3-6.

	<p>CAUTION:</p> <p><i>Vibrations and noise emission are directly correlated. Compliance with the instructions given for correct installation so as to reduce vibrations to a minimum is of equivalent importance for noise reduction.</i></p>
---	--

Since the noise emitted by a fan can be influenced by external factors that can affect the overall noise level, such as:

- the dimensions of the environment in which the fan is installed
- the presence of static elements near the fan (e.g. walls)
- the presence of other machines that are also sources of noise emission

FVI invites the user to measure ambient noise levels. It should be noted that the presence of other operating machines generates a "superimposition of effects" and resonance that multiply ambient noise.

In addition, in cases of restricted environments, or if the fan is installed against walls, the effect of reverberation and resonance on structures (walls and ceiling) is "exponential".

	<p>CAUTION:</p> <p><i>Avoid positioning fans in areas that could increase the noise risk.</i></p>
---	--

The definition of the risks to workers of exposure to noise is not the responsibility of **FVI**, which limits itself to indications of values, levels of uncertainty, standards or criteria used for noise emission measurements.

As envisaged by applicable legislation, it is the user that must assess the level of exposure of operatives to noise emissions using its own specific procedures, identifying:

- sources of noise and their relative importance
- average exposure times for each operative
- the level of direct and reflected noise
- the noise transmitted by structures and not through the air

	<p>CAUTION:</p> <p><i>Avoid working positions that increase the noise risk for operatives.</i></p>
---	---

	<p>CAUTION:</p> <p><i>Reducing exposure times and the use of Personal Protection Equipment will reduce the risks caused by exposure to noise emissions.</i></p>
---	--

If exposure to noise, in terms of sound pressure, exceeds 80 dBA, the employer must provide operatives with PPE for the hearing, such as earplugs or earmuffs. If exposure is equal to or higher than 85 dBA, the employer must take all possible action to ensure that PPE for the hearing is effectively used.

	<p>CAUTION:</p> <p><i>With sound pressures higher than 100 dBA, operatives may approach the fan only if it is not operating, even if wearing Personal Protection Equipment.</i></p>
---	--



3.8.7 General information on noise emission data

Level of acoustic power – L_wA

This is the average value of acoustic power expressed in dBA (value weighted according to scale A) emitted into the environment by a fan with ducting on both the intake and exit sides.

The value refers to channelled air with a density of 1.226 kg/m³, at the maximum permitted rotation speed of the impeller and with operation at the optimum point on the curve.

It is assumed that the fan is positioned in a free space, or in an area of dimensions such as to not cause significant reflection, and resting on a flat and rigid surface.

The possible contribution to the overall noise level of the noise caused by the motor, the transmission system and any accessories that may be present is not considered.

In addition, the value of background noise of the installation environment is not considered to be significant.

Level of acoustic pressure – L_pA

This is the average of the average temporal values of acoustic pressure emitted into the environment by a fan with ducting on both the intake and exit sides.

Pressure values are recorded on the measurement surface surrounding the fan (parallelepiped measurement surface).

Sound pressure measurements are obtained experimentally with 8 microphones located on the reference surface at a height equivalent to the fan rotation axis (see Fig. 3-13).

The pressure value is expressed in dBA (value weighted according to scale A).

The value refers to channelled air with a density of 1.226 kg/m³, at the maximum permitted rotation speed of the impeller and with operation at the optimum point on the performance curve.

The measured values refer to a measurement distance of one metre.

It is assumed that the fan is positioned in a free space, or in an area of dimensions such as to not cause significant reflection, and resting on a flat and rigid surface.

The possible contribution to the overall noise level of the noise caused by the motor, the transmission system and any accessories that may be present is not considered.

In addition, the value of background noise of the installation environment is not considered to be significant.

The point at which maximum acoustic pressure is found normally corresponds to the exit duct (external to the ducting), and its value is 3–4% higher than the average value.

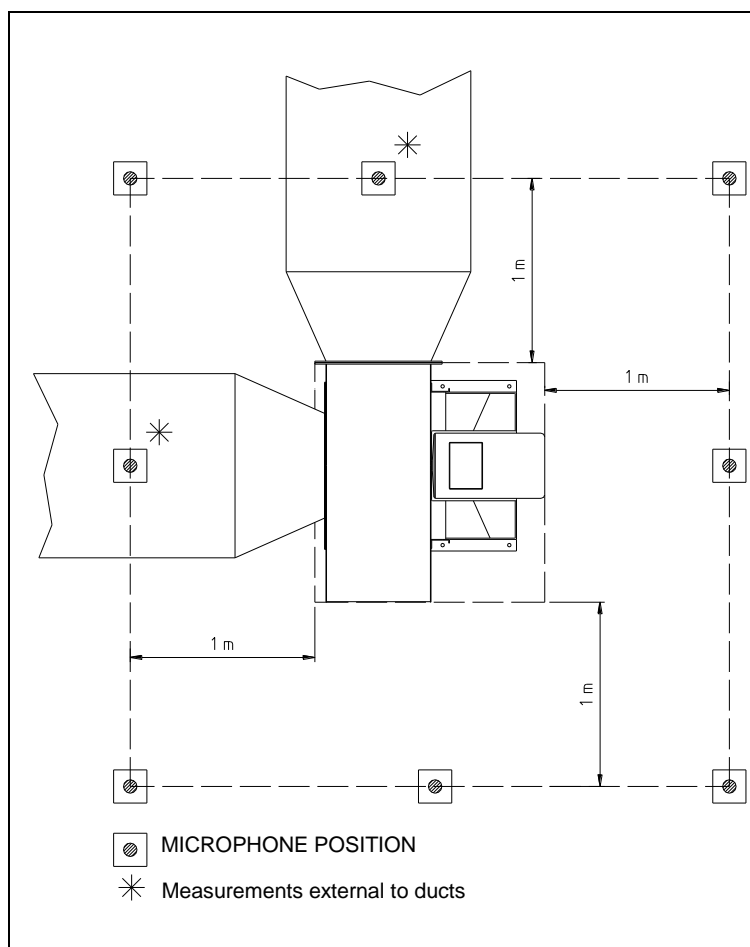

Fig. 3-13 Positions of measurement microphones

Reference standards

EN ISO 3744 - Determination of sound power levels of noise sources using sound pressure (engineering method in an essentially free field over a reflecting plane).

EN ISO 3746 - Determination of sound power levels of noise sources using sound pressure (survey method using an enveloping measurement surface over a reflecting plane).

ISO 13347 - Industrial fans - Determination of fan sound power level under standardized laboratory conditions.

ACOUSTIC POWER* EMITTED Lw(A) (dBA) (1/2) Axial fans – series with aluminium impeller hub									
size	ES ¹	EF ¹	EF vers.9	EB	EFR ²	EK ²	EQ ²	EP ²	ET ³
250					93				
280					97				
315	100	100	99		99	75	74	79	
355	100	100	98	102	103	77	77	85	
400	99	99	98	102	106	78	78	91	79
450	102	102	99	103	109	83	83	93	
500	102	102	100	103	112	86	84	96	85
560	107	107	101	105	116	89	88	87	
630	108	108	101	105	119		82	92	95
710	104	104	102	106	106		88		99
800	104	104	103	106	109		89		90
900	110	110	107	111			97		98
1000	110	110	106	110			99		99
1120	111	111	107	111					
1250	107	107	106	110					
1400	108	108	106	111					

* Uncertainty + 3 dB

Chart 3-3 Acoustic power emitted Lw(A) (dBA)

ACOUSTIC POWER* EMITTED Lw(A) (dBA) (2/2) Axial fans – series with steel impeller					
size	ES/H ¹	EF/H ¹	EF/H vers.9- 12	EB/H	EFR/P ²
560					115
630					118
710					122
800					110
900	111	111	111	115	113
1000	113	113	112	116	116
1120	115	115	113	117	120
1250	116	116	114	118	123
1400	117	117	114	119	126
1600	119	119	116	120	121
1800	122	122	117	121	
2000		123	118		

* Uncertainty + 3 dB

Chart 3-4 Acoustic power emitted Lw(A) (dBA)

¹ ducted only on exit

² ducted only on exit and at maximum synchronism speed

³ ducted only on intake and at maximum synchronism speed

ACOUSTIC PRESSURE* EMITTED Lp(A) (dBA) (1/2) Axial fans – series with aluminium impeller hub									
size	ES ¹	EF ¹	EF vers.9	EB	EFR ²	EK ²	EQ ²	EP ²	ET ³
250					80				
280					84				
315	87	87	86		86	62	62	67	
355	87	87	85	88	90	64	64	72	
400	86	86	85	88	93	65	65	78	65
450	89	89	86	89	96	70	70	80	
500	88	88	86	89	98	72	71	83	71
560	93	93	87	90	102	75	75	74	
630	94	94	87	90	105		68	78	80
710	90	90	88	91	91		74		84
800	89	89	88	91	94		75		74
900	95	95	92	95			83		82
1000	95	95	91	94			84		83
1120	95	95	91	94					
1250	91	91	90	93					
1400	92	92	90	93					

* Uncertainty + 3 dB

Chart 3-5 Acoustic pressure emitted Lp(A) (dBA)

ACOUSTIC PRESSURE* EMITTED Lp(A) (dBA)					
(2/2)					
Axial fans – series with steel impeller hub					
size	ES/H ¹	EF/H ¹	EF/H vers.9- 12	EB/H	EFR/P ²
560					101
630					104
710					107
800					95
900	96	96	96	99	98
1000	98	98	97	100	101
1120	99	99	97	100	104
1250	100	100	98	101	107
1400	101	101	98	101	109
1600	102	102	99	102	104
1800	104	104	99	102	
2000		105	100		

* *Uncertainty + 3 dB*

Chart 3-6 Acoustic pressure emitted Lp(A) (dBA)

¹ ducted only on exit

² ducted only on exit and at maximum synchronism speed

³ ducted only on intake and at maximum synchronism speed

4 TRANSPORT, MOVEMENT AND STORAGE

Lifting and movement operations with the fan may create hazardous situations for exposed persons. It is therefore advisable to follow the instructions provided by **FVI** and to use suitable equipment.

4.1 Lifting and movement

It is advisable to carry out all lifting and movement operations on the fan and its components with extreme care, avoiding impacts that may affect its correct operation or damage covered parts.

Use only the points indicated to lift the fan, distributing the load in a uniform manner.



Lifting points are identified with this symbol.



CAUTION:

The user assumes liability for the choice of the lifting equipment and ropes, straps or chains considered to be most suitable both for the purpose and for their lifting capacity. For lifting and movement, do not use zones or points other than those marked by a symbol.

4.2 General warnings for lifting separate fan parts

For reasons of transport, some fan parts may be delivered disassembled.



CAUTION:

- *All transport operations must be carried out only by qualified personnel, equipped with the correct PPE for protection against blows and/or falling objects.*
- *The movement of separate or disassembled parts of the machine must be carried out with suitable means of transport.*
- *For the correct movement of these parts, respect the indications on weight provided by **FVI**.*



Generally, special or specific equipment is not necessary for the lifting of fan parts.

4.3 Fan lifting instructions

4.3.1 Lifting version 1-9-12 axial fans

Lifting operations must be carried out by qualified personnel, suitably trained in the use of the equipment and equipped with the correct PPE for protection against blows and/or falling objects. Version 1 fans are supplied without motor. Version 9 fans are supplied with the motor supported by the casing. Version 12 fans have the motor fixed to the base. To lift them, the specific holes provided in the structure must be used (as shown in Fig. 4-1, Fig. 4-2, and Fig. 4-3). These holes are located on opposite sides above the centre of gravity, and are indicated by specific symbols.

In this case it is advisable to use a chain sling with two arms, the choice of which by the user must be compatible with the weight of the fan. In particular, the user must ensure that the weight load limit (WLL) of the sling is equal to or greater than the load to be lifted.

Slings with several arms (3 or 4) used with a number of arms that is less than the total number of arms composing the sling must be used with a lower WLL than the WLL marked on the sling, applying the factors indicated by standard UNI EN ISO 818-6 - A.1.3.7. It is advisable for unused arms to be gathered and hooked together, to reduce the risk of them swinging freely or being caught up during movement of the load.

Every time that a sling is used, it must be inspected beforehand for possible damage or evident signs of wear.

To connect the sling to the load, it is preferable to use the method with straight arms. In this case, the lower ends are connected directly to the attachment point. The hooks must be chosen so as to ensure that the load settles at the centre of the hook, preventing the tip of the hook from being loaded. The hook tips must also be oriented outwards, unless the hooks have been specifically designed for being used otherwise.

Before operating the lifting equipment, it is advisable to check that the load is free to move, and that it is not blocked by connection components or other obstacles to movement.

It is advisable to keep the hands and other body parts away from the chains, to prevent injuries when they are put under load. When lifting operations are ready to start, any slack must be taken up before lifting itself can start. The load must be lifted slowly, checking that it is firmly secured and that it moves into the required position. Reference must also be made to standard ISO 12480-1 to plan and manage lifting operations and to ensure that a safe working system is used.

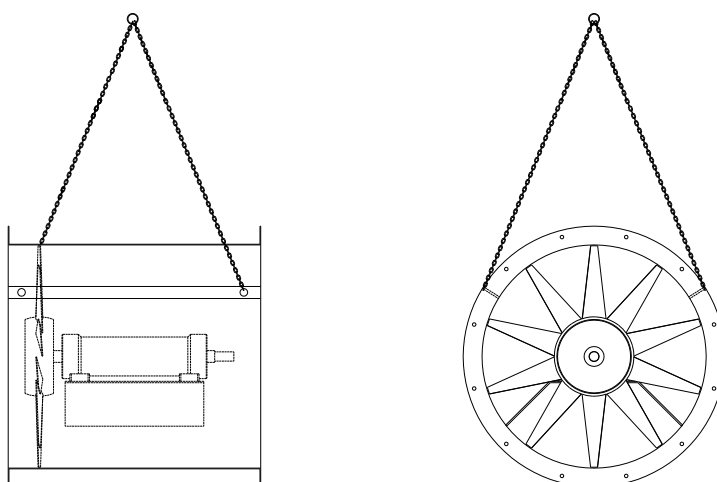

Fig. 4-1 Example of lifting version 1 axial fans

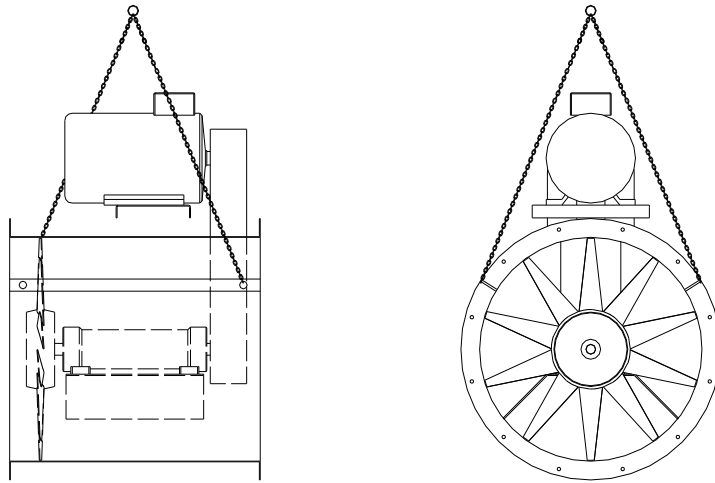

Fig. 4-2 Example of lifting version 9 EF axial fans

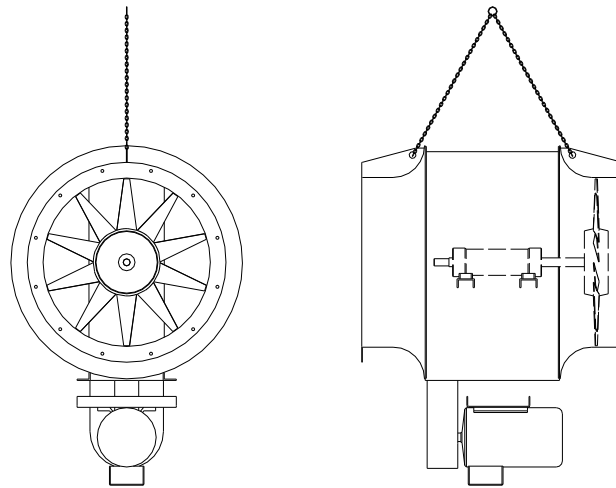

Fig. 4-3 Example of lifting version 9 EB axial fans

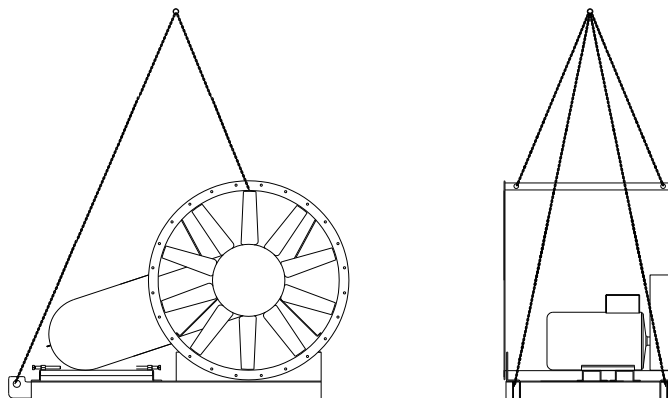

Fig. 4-4 Example of lifting version 12 axial fans

4.3.2 Lifting version 4 axial fans

Version 4 fans have the impeller fitted directly on top the motor shaft, and to lift them only the holes provided in the structure must be used (as shown in Fig. 4-5). These holes are located on opposite sides above the centre of gravity, and are indicated by specific symbols.

For the criteria to be applied in lifting operations the instructions provided in paragraph 4.3.1 must be followed.

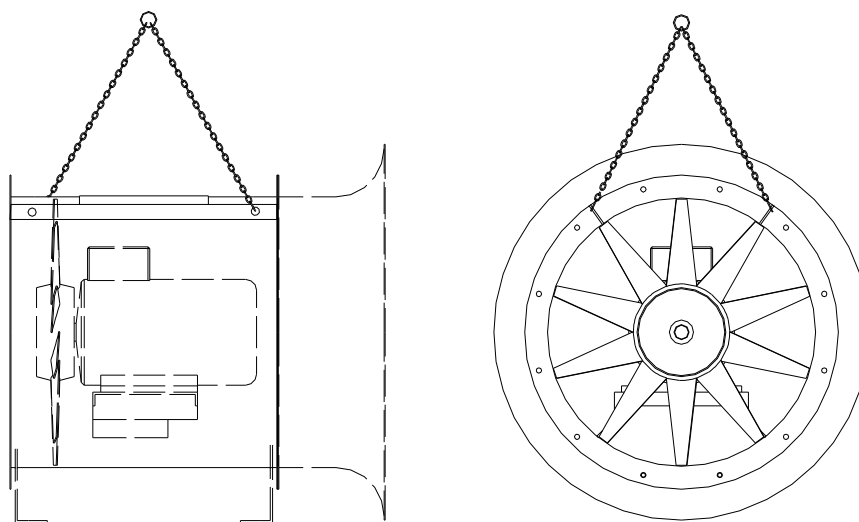

Fig. 4-5 Example of lifting version 4 EF axial fans

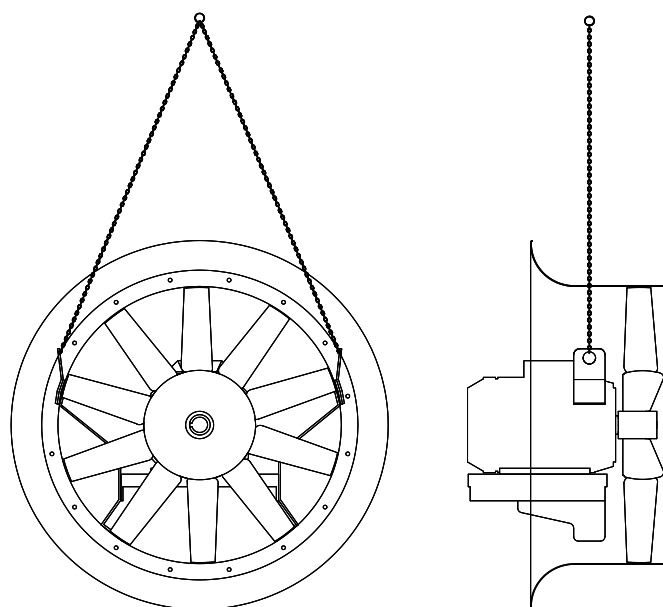

Fig. 4-6 Example of lifting version 4 A ES axial fans

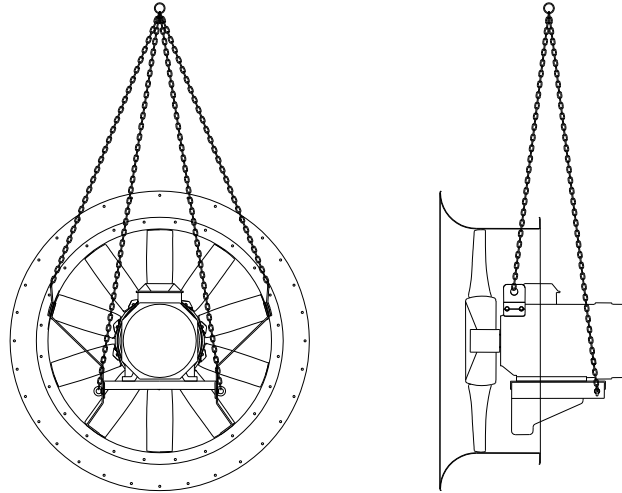

Fig. 4-7 Example of lifting version 4 B EF axial fans



CAUTION:

The lifting lugs on motors must never be used to lift the fan.

4.3.3 Lifting version 8 axial fans

The motor turns the impeller on version 8 fans by means of a flexible or a toothed coupling. To lift these fans only the specific holes provided in the structure must be used (as shown in Fig. 4.8).

The lifting symbols are located near the holes in the structure most suitable to balance the weight of the fan.

For the criteria to be applied in lifting operations the instructions provided in paragraph 4.3.1 must be followed.

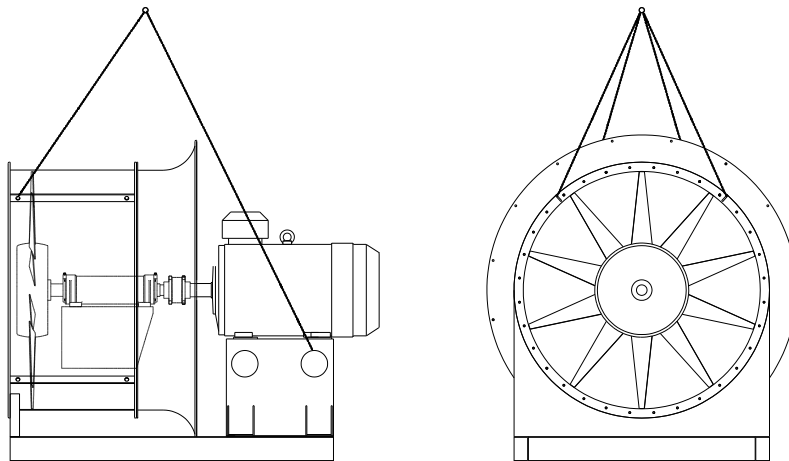

Fig. 4-8 Example of lifting version 8 axial fans



CAUTION:

The lifting lugs on motors must never be used to lift the fan.

4.3.4 Lifting fans packed in crate

The weight and centre of gravity of the crate are indicated on the outside of the package.

The lifting points for lifting the crate with a forklift truck are identified by two black triangles with the tip pointing downwards.

FVI ensures the stability of the fan or of fan components inside the case by means of rigid connections linked directly to the packing, so as to prevent any possible sudden movements of crate contents.

Nevertheless, while moving a crate with a forklift truck, the risk of instability or of the loss of stability caused by unforeseen movements of the forklift remains. To avoid this risk caused by unforeseen movements, care must be taken to carry out movement operations on a flat surface without projections or holes that could affect the stability of the loaded forklift truck. The speed of the forklift truck must also be reduced to a minimum, with the load at the minimum possible height.

Since the stability of the load is ensured when the position of the centre of gravity is located at a lower height vertically than the lifting point, whenever possible it is preferable to lift crates using lifting straps and/or chains.

	<p>CAUTION:</p> <p><i>Before lifting check:</i></p> <ul style="list-style-type: none"> • <i>that the capacity of the lifting equipment is compatible with the load</i> • <i>that the lifting equipment is in good condition</i> • <i>that the load has been correctly hooked up in safety</i> • <i>that the lifting point is vertically above the centre of gravity of the load</i> • <i>that the operator who carried out hooking up operations has moved away from the lifting areas</i>
--	--

	<p>CAUTION:</p> <p><i>Positioning of the lifting point at a significant distance from the vertical of the centre of gravity of the load can generate dangerous oscillations of the load when lifted.</i></p>
---	---

The load must be lifted away from the support surface with a very slow initial movement, so as to be able to identify any potential oscillations of the load. If residual oscillations of a nature that could be a hazard for persons or things during transport of the load are present after lifting it away from the support surface, it is advisable to wait for these oscillations to stop before starting transport operations.

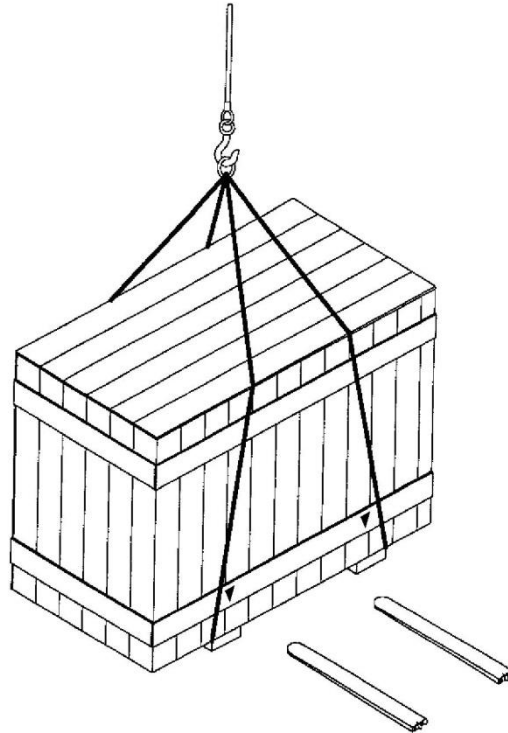

Fig. 4-9 Example of lifting fans packed in crate

4.4 Storage

If the fan is to be stored, it must be protected against weather conditions and damp, dust and the effects of atmospheric and environmental agents.



CAUTION:

Close intake and exit openings during storage.

It is advisable to periodically check the satisfactory state of conservation of the fan, and to manually rotate the impeller about once a month to prevent deformations to bearings.

5 INSTALLATION

5.1 General information



CAUTION:

All assembly operations must be carried out only by qualified personnel, equipped with the correct PPE for protection against blows and/or falling objects.



Generally, special or specific equipment is not necessary for the assembly of fan parts.

In the case of assembly of parts requiring a specific procedure, FVI will provide the additional information necessary for carrying out the operations correctly.

Special foundations are not necessary for positioning the fan. A well-levelled concrete support surface is sufficient, suitable to withstand the weight load of the fan and the dynamic stresses generated by its normal operation.

FVI designs and constructs its fans dedicating the greatest possible attention to the elimination of vibrations at their source. During installation, the user and/or installer must take the necessary measures to reduce vibrations from the overall system (fan and ducts).



It is advisable to use anti-vibration supports and joints to reduce to a minimum the transmission of vibrations during fan operation.

The support surface must be flat and horizontal, to prevent the bending and misalignment of supports. If necessary, suitable metal spacers must be placed between the fan base and the support surface to ensure perfect adherence. Use the fixing points provided, ensuring that the tightening of nuts and bolts does not deform fan structures.

The support surface must be sufficiently rigid to withstand normal fan vibrations, and must not be subject to phenomena of structural resonance.

If the fan is mounted on a structure raised above floor level, the vibration characteristics of this structure must be verified.

The necessary and sufficient parameters for the definition of the technical characteristics of the support structure to be used for fan installation are as follows:

- static load of the fan
- dynamic load of the fan
- position of the centre of gravity of the fan

These data are given in the SCHT01 technical information sheet supplied together with the fan described in this manual, or in the overall dimensions drawing.

The same information sheet also gives technical data for the type of vibration dampers and anti-vibration joints to be used.



FVI does not consider fixing by means of welding the fan structure to foundation plates to be an acceptable fixing method.

Ducting connected to the fan must be supported separately, and must be coaxial with respect to the intake and exit openings, so as to prevent deformation caused by the tightening of nuts and bolts.

	<p>CAUTION:</p> <p><i>All installation operations must be carried out only by qualified personnel, authorized, using suitable equipment and equipped with the correct PPE for protection against blows and/or falling objects.</i></p>
--	---

	<p>CAUTION:</p> <p><i>During installation, the conservation of the minimum access spaces requested for maintenance operations must be verified.</i></p>
--	--

	<p>CAUTION:</p> <p><i>The use of flow regulation devices connected directly to the fan intake may generate instable operation.</i></p>
--	---

5.1.1 Minimum installation distances

If possible in the available space, to guarantee correct entry of the fluid into the intake opening it is advisable on fans connected to ducting to leave a straight section of duct with a length about 2.5 times the fan size (given on the identification plate). The result of this calculation divided by 1000 gives the recommended length (in metres).

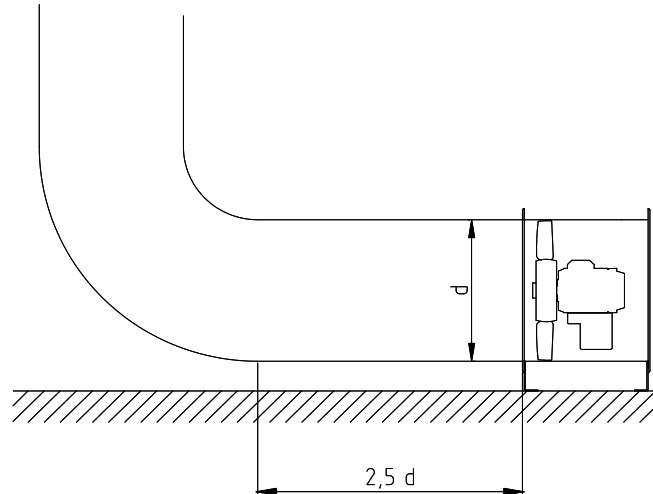

Fig. 5-1 Minimum installation distances with intake duct

If the fan is installed with a free intake opening, it must be positioned at a minimum distance from walls or other machinery of 1.5 times the fan size (given on the identification plate). The result of this calculation divided by 1000 gives the recommended minimum distance (in metres).

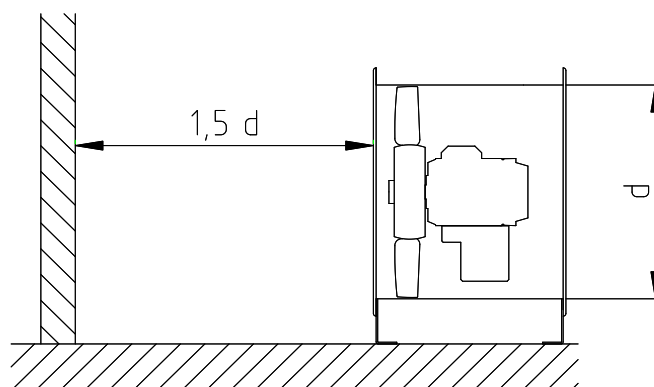

Fig. 5-2 Minimum installation distances with free intake

5.2 Assembly of axial fans

The main steps of the assembly of axial fans in the various versions supplied are illustrated below.

5.2.1 Version 4 axial fans

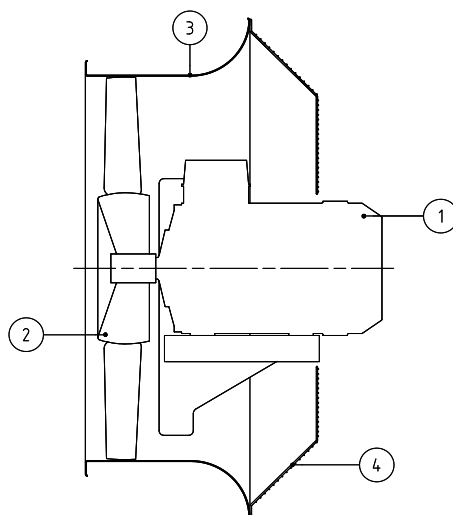

Fig. 5-3 Assembly of version 4 axial fans

Step	Operation	Description
1	Positioning of motor [1]	The motor must be positioned on its base without fully tightening its fixing fasteners.
2	Fitting of impeller [2] on motor shaft	 <p>IMPORTANT:</p> <p><i>If necessary, reduce the diameter of the motor shaft until its nominal size is reached with a tolerance of +0/+5 microns. Assembly with excessive play can cause vibrations. Forced assembly creates deformations and vibrations, also making it more difficult to remove the impeller.</i></p> <p>After the impeller has been fitted to the projection on the motor shaft and the head washer has been fully fixed, a check must be made to ensure that the clearance between the impeller and the casing (3) is constant around the entire circumference. If clearance is not constant, correct the position of the motor support base.</p>
3	Fixing of motor	Fully tighten the motor fixing nuts (see paragraphs 10.1.1 and 10.2.1 for details).
4	Fitting of guards [4]	Protect all moving parts with the envisaged guards.

Chart 5-1 Sequence of operations for assembly of version 4 fans
(refer to Fig. 5-3 for the identification of components)

5.2.2 Version 1 axial fans

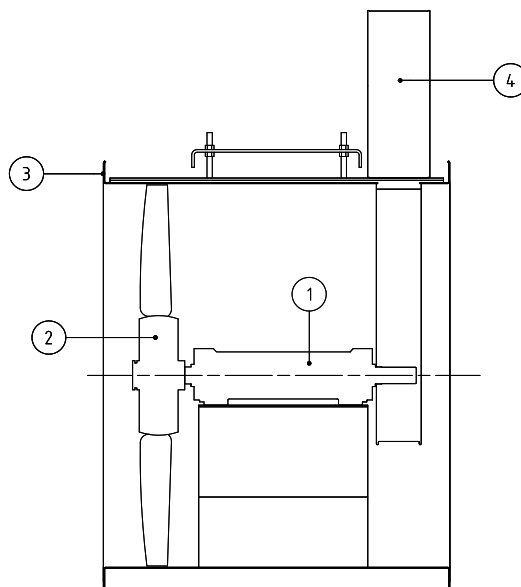

Fig. 5-4 Assembly of version 1 axial fans

Step	Operation	Description
1	Positioning of support [1]	The support must be positioned on its base without fully tightening its fixing fasteners.
2	Fitting of impeller [2] on support	 <p>IMPORTANT:</p> <p><i>If necessary, reduce the diameter of the motor shaft until its nominal size is reached with a tolerance of +0/+5 microns. Assembly with excessive play can cause vibrations. Forced assembly creates deformations and vibrations, also making it more difficult to remove the impeller.</i></p> <p>After the impeller has been fitted to the projection on the support shaft and the head washer has been fully fixed, a check must be made to ensure that the clearance between the impeller and the casing (3) is constant around the entire circumference. If clearance is not constant, insert compensation spacers beneath the support feet. Axial fans with FVI transmissions are all fitted with the type ST one-piece support as the standard version (see paragraph "9.1 ST supports versions A – AL – B -BL").</p>
3	Fixing of support	Fully tighten the support fixing nuts (see paragraphs 10.1.1 and 10.2.1 for details).
4	Fitting of guards [4]	Protect all moving parts with the envisaged guards.

Chart 5-2 Sequence of operations for assembly of version 1 fans
(refer to Fig. 5-4 for the identification of components)

5.2.3 Version 9-12 axial fans

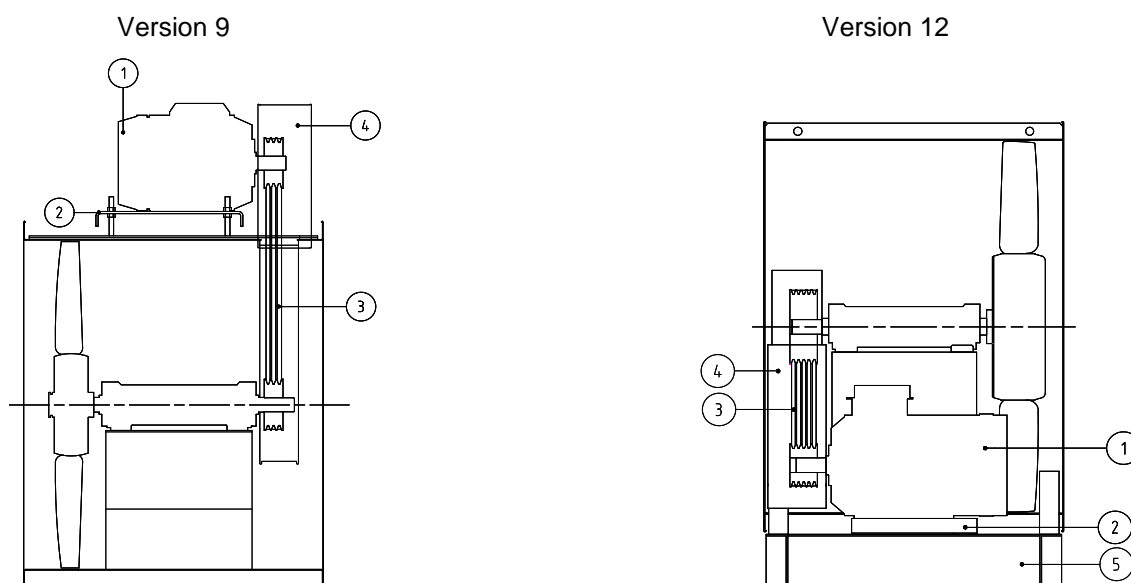

Fig. 5-5 Assembly of version 9 and 12 axial fans

After completing steps 1-2-3 indicated in paragraph 5.2.2, proceed with the installation of the transmission.

Step	Operation	Description
1	Installation of casing	Position the casing on the base [5] (only for version 12)
2	Installation of motor [1]	Position the motor on its base [2] complete with stays (version 9) or on the slides [2] of the base (version 12), without fully tightening fasteners.
3	Fitting of pulleys with tapered bush and fitting and positioning of V-belts [3]	Pulleys must be fitted so as to ensure their correct alignment and tightening. To do this, regulate motor position (see paragraphs 5.3 and 8.4 for fitting and tightening of drive belts). After identifying the correct position, motor fixing fasteners must be fully tightened.
4	Fitting of guards (4)	Protect all moving parts with the envisaged guards.

Chart 5-3 Sequence of operations for assembly of version 9-12 fans
(refer to Fig. 5-5 for the identification of components)

5.2.4 Version 8 axial fans

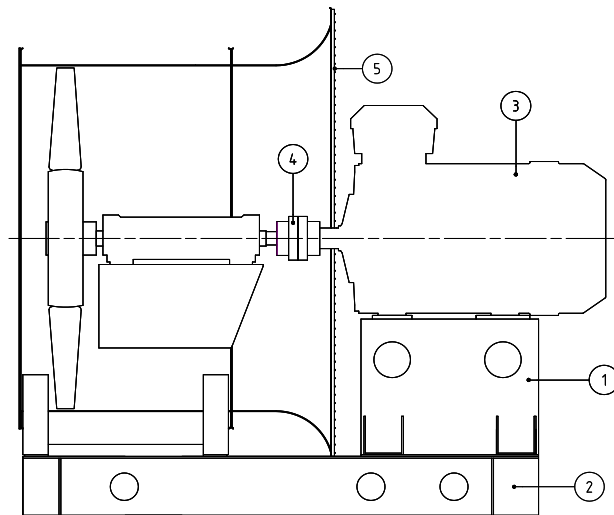

Fig. 5-6 Assembly of version 8 axial fans

After completing steps 1-2-3 indicated in paragraph 5.2.2, proceed with the installation of the transmission.

Step	Operation	Description
1	Installation of casing and motor pedestal [1]	Position the casing and motor pedestal on the base [2].
2	Installation of motor [3]	Position the motor on the motor pedestal without fully tightening fasteners.
3	Fitting of flexible or toothed coupling [4]	When fitting the coupling, alignment must be checked as indicated in paragraph 8.5. To do this, regulate motor position. After identifying the correct position, motor fixing fasteners must be fully tightened.
4	Fitting of guards [5]	Protect all moving parts with the envisaged guards.

Chart 5-4 Sequence of operations for assembly of version 8 fans
(refer to Fig. 5-6 for the identification of components)

5.3 Installing and adjusting drive belts and final checks

If the fan is fitted with a **V-belt drive**, the transmission is assembled as follows:

- Carefully clean tapered parts and the bush hole before fitting it onto the pulley.
- Fit the bush onto the pulley, taking care to align the threaded half-holes on the pulley with the unthreaded half-holes on the bush.
- Screw in the grubscrews by hand without fully tightening them.
- Fit the assembly onto the shaft, after carefully cleaning it.
- Position the pulleys and check their alignment with a straight edge.
- Lock in place, tightening screws alternately.
- Fit the belts.
- Do not force the belts with a lever, to avoid damaging the fibres of the internal reinforcement.
- Before tensioning the belts, mark a known length on the taut side (e.g. 100 mm) and, rotating the transmission, gradually tension the belts (as described in paragraph 8.4) until a relative increase in length is obtained of:

0.8% for uniform torque;

1% for irregular torque.

	<i>Excessive belt tension may damage bearings and cause shaft breakage.</i>
---	---

	<p>CAUTION:</p> <p><i>On transmissions with flexible couplings, alignment must be checked before starting the fan, as the motor pedestal could have been deformed during transport or due to tightening of the foundation bolts.</i></p>
---	--

5.4 Electrical connections

	<p>CAUTION:</p> <p><i>The fan is supplied in conformity with Directive 2014/30/EC on electromagnetic compatibility. In particular, the electric motor, if supplied with the fan, is guaranteed by its manufacturer to be conformant to this directive. It is the responsibility of the installer to check that the system in which the fan is inserted is conformant to the directive. If the motor is not supplied with the fan but is fitted by the customer, it is compulsory for the customer to check that it is conformant to the directive.</i></p>
---	---

The mains power supply line to the fan must be able to deliver sufficient power.

Connections to the mains power supply must be made by qualified personnel equipped with suitable PPE to protect against electrical hazards, remembering that the customer is always responsible for the electrical power supply through to the motor connection terminals.

Customers are reminded of the need to ensure all safety conditions for the grounding of the fan.

The grounding system must be conformant with applicable legislation in the country of installation, and must be regularly checked by qualified personnel.

Make the connection to the grounding connector before making all other connections.

Check that the connection layout (see Fig.) is suitable for the power supply voltage.

Standard electric motors can normally operate indifferently in both rotation directions. To invert the rotation direction, it is sufficient to exchange any two of the power supply cables directly on the terminal board.

	<p>CAUTION:</p> <p><i>It is the responsibility of the installer to provide an electrical power supply system for the fan in conformity with the EN 60204-1 standard.</i></p> <p><i>In particular, an electrical cut-off switch must be provided near the fan, so that maintenance personnel have direct control over power supply to the fan (see points 9.2.6.3 Enabling Control and 10.7 Emergency Stop Devices of the EN 60204-1 standard).</i></p>
--	---

In addition, the designer of the electrical system must provide controls for starting, normal stopping and emergency stopping, in conformity with Annex I of MACHINERY DIRECTIVE 2006/42/EC.

	<p>CAUTION:</p> <p><i>It is the responsibility of the customer and/or electrical installer to choose the correct size and type of the device and of cables used for electrical connections to the fan, depending on the motor installed and the mains power supply system.</i></p>
--	---

Work may be done on electrical components only with the fan at a standstill and disconnected from the electrical power supply.

Before installation and starting, check that the data on the motor identification plate are in conformity with the characteristics of the electrical power supply system.

<i>The layouts shown are merely indicative. Consult the connection layout provided by the motor manufacturer.</i>		
Triple-phase single-speed motors	Triple-phase motors Single winding Single voltage	Triple-phase motors Two separate windings Single voltage
Delta connection	Dahlander or PAM connection for high speed	Connection for high speed
Star connection	Dahlander or PAM connection for low speed	Connection for low speed

Fig. 5-7 Diagram of electrical connections for one-speed and two-speed motors

Openings for cable entries must be made in a way that prevents the cables from coming into contact with sharp edges or moving parts, and in particular the impeller. If openings for cable entries must be made in the casing, the openings must be fitted with suitable protective devices (grommets). In this case, consult the FVI Technical Office. These precautions are applicable in particular if an external terminal box is fitted (EF series: see fig. 5 – 8). On EFR series fans, the external terminal box is already provided by FVI.

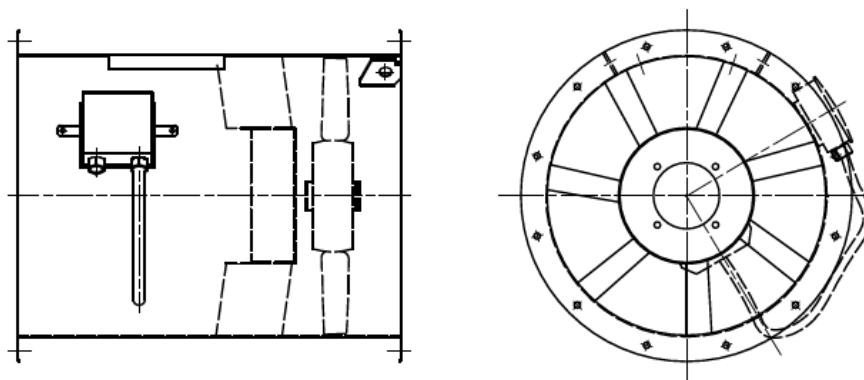

Fig. 5-8 Example of positioning of external terminal box

The type of sheath protecting cables must be chosen according to the fluid moved by the fan. Unless otherwise specified, FVI considers that the fan is used to move clean air.

Electrical connections to the external terminal box must be made with the same IP protection level as the motor.

5.5 Connection to ducts

The fan must be connected to ducting with all parts correctly aligned, without obstructions to air flow from gaskets or flexible components. The weight of ducting must not be supported by the fan, and deformations of parts of the machine by ducting connections must be avoided. Any flexible joints between the fan and intake and/or exit ducts must be installed in a way that prevents stress on flexible components, and that avoids contacts between metallic parts of the joints (see fig. 5-9 for assembly tolerances).

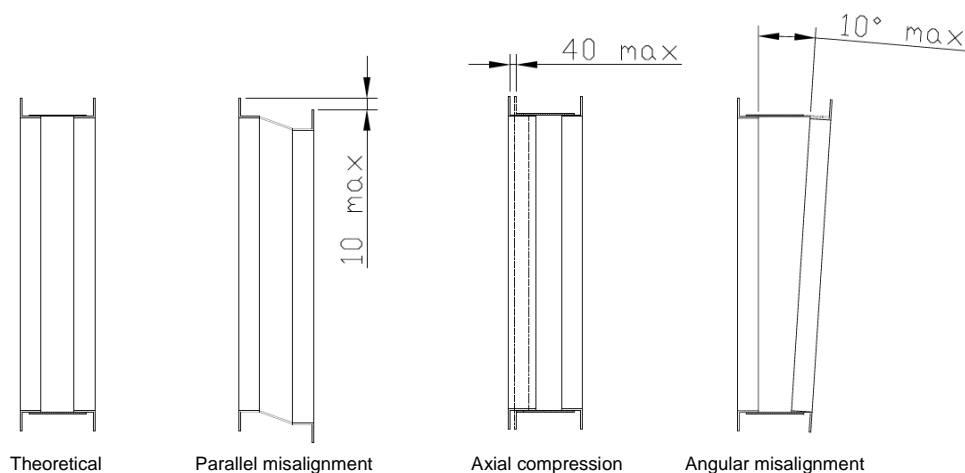

Fig. 5-9 – Assembly tolerances for flexible joints

If possible in the available space, to guarantee correct entry of the fluid into the intake opening it is advisable on fans connected to ducting to leave a straight section of duct with a length about 2.5 times the fan size (given on the identification plate). The result of this calculation divided by 1000 gives the recommended length (in metres).

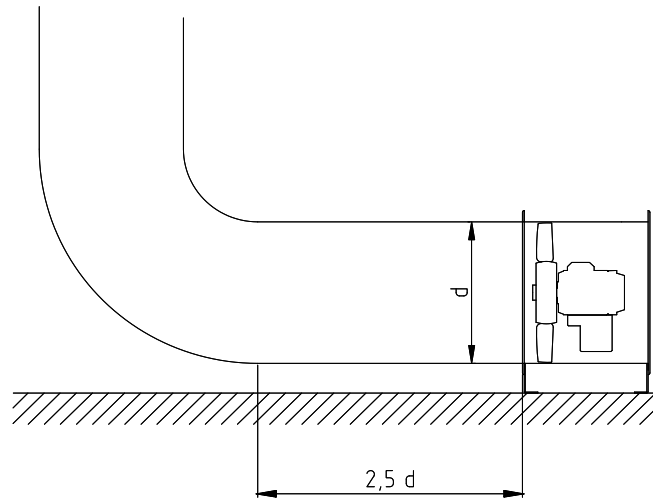



Fig. 5-10 Minimum installation distances with intake duct

6 CHECKS TO BE MADE BEFORE AND AFTER STARTING

6.1 Preliminary checks and first starting of the machine

	<p>CAUTION:</p> <p><i>Preliminary checks before the first starting must be made only with the fan at a standstill and disconnected from electrical power supplies.</i></p>
---	---

Before the fan is started for the first time a number of preliminary checks are necessary:

- Verify the compatibility of the fan for its intended application.
- In case of completion of the transmission by the installer, verify the compatibility of the fan identification plate with the transmission specifications document.
- Check that all guards are present.
- Check that all nuts, bolts and other fasteners envisaged by **FVI** are present.
- Check that all nuts, bolts and other fasteners (impeller, supports, foundation, transmission if present) are correctly tightened.
- Check the correct lubrication of the fan and motor bearings, and if necessary replace the grease (see chapter 8 MAINTENANCE).
- Check that all rotating parts can turn freely.
- Check for the absence of objects or foreign bodies inside the fan.
- Starting the machine requires no particular operations other than the supply of electrical power to the motor. Always check that the supply voltage corresponds to the voltage envisaged for use of the machine and is compatible with the voltage indicated on the motor identification plate. In case of use with an inverter, the fan must be started by gradually varying the frequency of the inverter from zero up to the value envisaged for normal operating speed. The same procedure must also be used every time the machine is started subsequently.
- Check that the rotation direction is correct. A short burst of electrical power is sufficient to check that the rotation direction is the same as that indicated on the fan casing. If necessary invert the rotation direction (see Electrical connections).

FVI recommends the use of the checklist given in paragraph 12.2 to record the necessary checks for safety conditions.

	<p>CAUTION:</p> <p><i>Operating trials must not be permitted before the checks of the checklist have been made (see paragraph 12.2).</i></p>
---	--

	<p>CAUTION:</p> <p><i>Axial fans must never operate with their openings completely closed.</i></p>
---	---



6.2 Checks to be made with fan fully operating

Check that power absorption does not exceed the value indicated on the motor identification plate. If it does, **immediately halt the fan and contact the manufacturer.**

Fan operation must be free from excessive vibrations and abnormal noise.

With the fan at a standstill, check that the temperature of the bearings does not exceed the limits of tolerance (with an ambient temperature of 20°C, the temperature of supports must be no higher than 70°C). It must be taken into consideration that in the first hours of operation, a higher temperature than that indicated may be normal, if it then falls to a lower value. In case of abnormal overheating of bearings, consult the **FVI** technical service.

After 3–4 hours of operation, with the fan at a standstill and disconnected from the power supply, repeat the checks on the tightness of nuts and bolts, bearing temperatures, and for fans with transmission, the temperature and tension of drive belts.

On request, **FVI** fans can be fitted with vibration and/or temperature sensors for support bearings (for fans with transmission). In this case, **FVI** installs the vibration sensor on the impeller side of the support, and the temperature probe on the transmission side of the support.

With regard to vibrations, the criterion for the verification of conditions of safety refers to standard ISO 14694:2003, which recommends the following limits for mechanical vibrations (vibration speed in mm/s RMS), measured in installation conditions:

- **alarm: 7.1 (rigid), 11.8 (flexible);**
- **stop: 9 (rigid), 12.5 (flexible);**

These limits are considered to be valid by **FVI** in general, with the exception of specific indications for individual applications.

Measurement point and direction: on fan supports or motor, in a direction perpendicular to the rotation axis, on the horizontal or vertical plane.

The use of the definition of rigid and flexible refers to the fact that the structure reaches its first critical speed higher or lower respectively than operating speed. **FVI** fans normally have a rigid structure with regard to this definition.

The type of vibration damper used affects the value of the first critical speed.

The reference limits for temperature on supports, measurable on the external bearing ring regardless of ambient temperature, are as follows:

- **alarm 100 °C;**
- **stop 120 °C;**

6.2.1 Visual checks on guards

For mesh guards, checks must be made for the following:

- Corrosion or dullness of galvanized surfaces
- Detachment of rivets/welds
- Evidence of noises typical of loose guards
- Impacts and permanent deformation of components
- Breakage of wires
- Corrosion of fasteners
- Slackening of fixing elements

For guards in pressed and painted sheet metal, checks must be made for the following:

- Corrosion or dullness of painted surfaces
- Detachment of rivets/welds
- Evidence of noises typical of loose guards
- Impacts and permanent deformation of components
- Mechanical deformation or breakage of guards
- Presence of cracks
- Corrosion of fasteners
- Slackening of fixing elements

	<p>CAUTION: <i>All guards must be inspected every month and replaced if necessary.</i></p>
---	--

	<p>CAUTION: <i>In case of doubts, carry out checks more frequently or replace the guard.</i></p>
---	--

6.2.2 Checking and cleaning parts in contact with fluids

The periodical cleaning of the impeller prevents vibrations that might be caused by any dust deposits that accumulate while the fan is running.

If the fan is used for the movement of even slightly dusty fluids, the Impeller must be inspected periodically for cleanness and/or wear.

Deposits of material or wear on impeller parts may cause abnormal fan vibrations.

6.2.3 Visual checks on impeller and casing

Periodical visual checks must be made for wear on impeller blades, given that deterioration of these parts can create a condition of extreme risk, due to the ejection of the blade or the failure of structural components, with consequences that may even be fatal.

	<p>CAUTION: <i>Axial fans must not be used for fluids containing abrasive agents.</i></p>
---	---

To monitor **phenomena of accidental abrasion** on impeller blades and the casing, use a portable lamp to visually inspect components, slowly rotating the impeller to allow all blades to be seen. Blades must be totally free from damage and must show no signs or abrasion or missing sections.

With regard to the **phenomenon of corrosion** on impeller blades and the casing, corrosive and acidic environments can reduce the thickness of fan safety components.

This phenomenon must not be underestimated, also because it does not depend solely on the concentration of aggressive agents.

Condensation may form during pauses in fan operation, and this may accelerate the phenomenon of chemical corrosion, which in turn may alter the thickness of components, affecting their integrity.



6.2.4 Dimensional checks

CHECKLIST – DIMENSIONAL CHECKS ON COMPONENTS			
COMPONENTS TO CHECK	TYPE OF CHECK/INSTRUMENT	CRITERIA FOR ACCEPTABILITY	RESULT
Impeller: presence of scratches or grooves on surfaces	Visual	Undamaged	OK <input type="checkbox"/>
Casing: sheeting thickness	Dimension/Caliper or equivalent	Reduction of thickness no greater than 10% in an area without wear	OK <input type="checkbox"/>
Intake: thickness (if present)	Dimension/Caliper	Reduction of thickness no greater than 20% in an area without wear or with paint undamaged	OK <input type="checkbox"/>
Anti-vibration joints: thickness of anti-wear sheeting (if present)	Dimension/Caliper	Reduction of thickness no greater than 20% in an area without wear or with paint undamaged	OK <input type="checkbox"/>
Welding (entire structure)	Visual	Absence of damage and cracks	OK <input type="checkbox"/>
Date:			
Signature:			

7 AXIAL FAN OPERATING MALFUNCTIONS

7.1 Most frequent malfunctions

The following chart lists the main problems that may be encountered:

PROBLEM	CAUSE	SOLUTION
Fan does not start	No electrical connection	Check that the motor and/or command inverter to the electrical power supply line and is correctly powered
	Motor malfunction	Check internal connections and motor components and replace if necessary
	No connection between command inverter and motor	Check for correct connection between inverter and motor
	Command inverter malfunction	Check internal inverter circuits and components and replace if necessary
Power absorption lower than design value	Rotation speed too low	Increase rotation speed
	Impeller partially blocked	Eliminate obstruction
	Resistance pressure of system lower than design value	Check the resistance pressure value of the system
	Fluid density lower than intended value	Check the fluid density value
Power absorption higher than design value	Incorrect blade angle	Increase blade angle
	Rotation speed too high	Reduce rotation speed
	Resistance pressure of system greater than design value	Check the resistance pressure value of the system
	Openings or ducting partially blocked	Eliminate obstruction Check the position of adjustment organs
	Pre-rotation of air in opposite direction to fan rotation	Check minimum installation distances (paragraph 5.1.1)
	Fluid density higher than intended value	Check the fluid density value
	Power supply to motor with voltage lower than shown on identification plate	Check for correct voltage of power supply to motor
	Defects in motor windings	Check for correct motor operation
Incorrect blade angle	Reduce blade angle	
Insufficient pressure	Rotation speed too low	Increase rotation speed
	Fluid density lower than intended value	Check the fluid density value
	Air flow greater than intended value	Check the resistance pressure value of the system
Pulsating operation	Instability of air flow	Check operating field envisaged by operating curve
	Fluctuations in flow due to other fans operating in parallel	Check for correct installation on system
	Intake air turbulence created by system near intake opening	Check minimum installation distances (paragraph 5.1.1)

PROBLEM	CAUSE	SOLUTION
Vibrations	Pulsating operation	See previous point "Pulsating operation"
	Structural resonance at specific rotation speeds	Use the inverter to avoid operation at these speeds or modify frequencies of the overall system
	Wear on impeller parts	Inspect the impeller
	Deposit of material on impeller	Inspect the impeller
	Friction between moving parts	Check for correct coupling between moving parts
	Intrinsic bearing defects	Check condition of bearings
	Bearing malfunctions due to unbalanced impeller or excessive belt tension	Check condition of bearings Check belt tension (see paragraph 8.4)
Excessive noise	Friction between moving parts	Check for correct coupling between moving parts
	Vibrations	See previous point "Vibrations"
	Pulsating operation	See point "Pulsating operation"
	Electromagnetic motor malfunctions	Check for correct conditions of power supply to motor (inverter)
	Presence of holes or sharp projections	Check for presence of rounded projections in points with high air speed

8 MAINTENANCE

	<p><i>Read this section carefully before carrying out maintenance operations on the fan. This will ensure greater conditions of safety for maintenance personnel and greater reliability of the work done.</i></p>
---	--

The safety rules to be respected during maintenance operations on the fan are as follows:

- Maintenance and/or lubrication operations must be carried out only by qualified and expert personnel, authorized by the technical management of the factory, in conformity with applicable safety directives and standards, using tools, equipment and products suitable for the purpose.
- During maintenance operations, suitable clothing must be worn, such as closely-fitting overalls and safety footwear, absolutely avoiding garments that are bulky or with loose parts.
- During maintenance operations on the fan, it is advisable to fence it off and to identify it with signs with the wording: "FAN UNDERGOING MAINTENANCE".

	<p>CAUTION:</p> <p><i>The fan must be disconnected and isolated from the electrical power supply during maintenance operations. Always check that the impeller and motor are at a standstill before accessing the fan and its components or opening the inspection hatch.</i></p> <p><i>In the case of fans that move hot fluids, wait for the fan to cool down before carrying out maintenance operations, so as to prevent contact with surfaces at high temperatures.</i></p>
--	---

In the case of maintenance operations on rotating parts or parts inside ducts, it is also necessary:

- where present, to disconnect the flexible motor coupling;
- where present, to remove drive belts from pulleys.

	<p>CAUTION:</p> <p><i>In the case of use of a multi-stage fan, disconnect the electrical power supply <u>from the entire multi-stage fan</u> and check that the impeller is at a total standstill before carrying out any maintenance operation.</i></p>
---	--

The person responsible for maintenance must use a team of persons so as to guarantee absolute coordination between the persons and the maximum safety for persons exposed to risk. All persons preparing to carry out maintenance operations must be in full visual contact to warn of possible hazards.

	<p>CAUTION:</p> <p><i>Any necessary movement of parts to be removed or disassembled from the machine must be made with suitable transport and lifting equipment.</i></p>
---	---

	<p><i>Generally, special or specific equipment is not necessary for the fan maintenance operations.</i></p>
---	---

	<p><i>Full systematic maintenance of the fan is necessary for its normal correct operation, and is also a factor of safety for operatives.</i></p>
---	--

To facilitate the planning of programmed maintenance, **FVI** has compiled a chart (see paragraph 12.3) with general indications of the points to be monitored and the frequency of checks.

	<i>Periodic cleaning and maintenance, together with lubrication, are essential to ensure correct fan operation and a longer operative lifespan of the fan.</i>
---	--

8.1 Bearing lubrication

	<i>Both type SN and type ST supports assembled by Ferrari already contain the correct quantity of lubricant, as indicated in Chart 8-1. No lubricant filling operations are therefore required during installation.</i>
---	---

Check bearing lubrication at the recommended intervals.

The bearing installed in the supports of fans with transmission must be lubricated at the intervals and using the quantity of grease indicated in the transmission specifications document attached to the fan documentation, if the fan has been supplied complete with transmission. For version 1 fans (shaft only, without transmission), consult Chart 8-2 for the correct lubrication interval. Lubricate using the recommended type of grease or an equivalent type. If the fan operates in a dusty, damp, hot or corrosive environment, lubrication intervals must be reduced by approximately 40% or more with respect to the value indicated on the transmission specifications document, depending on the harshness of the operating environment.

	<i>An excessive quantity of lubricant causes bearing overheating. Avoid filling supports with a quantity of grease greater than that recommended.</i>
--	---

Unless otherwise indicated, the grease used in the bearings of **FVI** fans on delivery is:



SHELL GADUS S3 V100 2

This is a lithium-based soap complex, with a dropping point of 250°C (IP 396) and a cone penetration value at 25°C – 0.1 mm (IP 50/ ASTM D217) of 265–295. Kinematic viscosity (IP 71/ ASTM D445): at 40°C, 100 cSt; at 100°C, 11.3 cSt.

The following greases have comparable characteristics:

	S.R.I. GREASE 2
	ALETIUM GREASE 2
	MOBIPLEX 47
	RUBENS
	GP GREASE
	CERAN WR 2
	CASTROL SUPER GREASE 2

<i>Support type</i>	<i>Quantity of grease for first filling (g)</i>
SN 507 ...	50
SN 508 ...	60
SN 509 ...	65
SN 510 ...	75
SN 511 ...	100
SN 512 ...	150
SN 513 ...	180
SN 516 ...	280
SN 517 ...	330
SN 518 ...	430
SN 520 ...	630
SN 522 ...	850
SN 524 ...	1000
SN 526 ...	1100
SN 528 ...	1400
SN 530 ...	1700
ST ...	Fill the bearing completely but fill the free space in the support only partially

Chart 8-1 Quantity of grease for first filling of supports and bearings on fans with transmission



Bearings on motors up to the size of 160 are normally life-long lubricated, and therefore do not require lubrication.

Check and lubricate bearings at the intervals recommended by the motor manufacturer. It is always advisable to periodically substitute bearings with replacements as indicated on the motor identification plate.



Use the type of grease recommended by the motor manufacturer to lubricate motor bearings.



Support type	Bearing type (pulley side)	Rotation speed (RPM)					Grease quantity (grams)	Bearing type (side opposite pulley)	Rotation speed (RPM)					Grease quantity (grams)
		1060	1500	2120	3000	4250			1060	1500	2120	3000	4250	
		Relubrication intervals in hours							Relubrication intervals in hours					
ST 47 A-AL	6204 Z	12500	8000	6300	4000	3150	4	6204 Z	12500	8000	6300	4000	3150	4
ST 62 A-AL	6305 Z	11200	7100	5600	3550	2800	5	6305 Z	11200	7100	5600	3550	2800	5
ST 80 A-AL	6307 Z	10000	6300	5000	3150	2500	7	6307 Z	10000	6300	5000	3150	2500	7
ST 90 A-AL	6308 Z	9000	5600	4500	2800	2240	9	6308 Z	9000	5600	4500	2800	2240	9
ST 90 B-BL	NU 308 ECP	4500	2800	2250	1400	1120	9	6308 Z	9000	5600	4500	2800	2240	9
ST 100 A-AL	6309 Z	8000	5000	4000	2500	2000	11	6309 Z	8000	5000	4000	2500	2000	11
ST 100 B-BL	NU 309 ECP	4000	2500	2000	1250	1000	11	6309 Z	8000	5000	4000	2500	2000	11
ST 110 A-AL	6310 Z	7100	4500	3550	2240	1800	14	6310 Z	7100	4500	3550	2250	1800	14
ST 110 B-BL	NU 310 ECP	3550	2250	1800	1120	900	14	6310 Z	7100	4500	3550	2250	1800	14
ST 120 A-AL	6311 Z	6300	4000	3150	2000	1600	18	6311 Z	6300	4000	3150	2000	1600	18
ST 120 B-BL	NU 311 ECP	3150	2000	1600	1000	-	18	6311 Z	6300	4000	3150	2000	1600	18
ST 130 A-AL	6312 Z	5600	3550	2800	1800	-	22	6312 Z	5600	3550	2800	1800	-	22
ST 130 B-BL	NU 312 ECP	2800	1800	1400	900	-	22	6312 Z	5600	3550	2800	1800	-	22
ST 150 A-AL	6314 Z	5000	3150	2500	1600	-	28	6314 Z	5000	3150	2500	1600	-	28
ST 150 B-BL	NU 314 ECP	2500	1600	1250	800	-	28	6314 Z	5000	3150	2500	1600	-	28
ST 180 A-AL	6317	4500	2800	2240	1400	-	36	6317 Z	4500	2800	2240	1400	-	36
ST 180 B-BL	NU 317 ECP	2250	1400	1120	-	-	36	6317 Z	4500	2800	2240	1400	-	36
ST 200 A-AL	6319	4000	2500	2000	-	-	45	6319 Z	4000	2500	2000	-	-	45
ST 200 B-BL	NU 319 ECP	2000	1250	1000	-	-	45	6319 Z	4000	2500	2000	-	-	45
Support type	Bearing type (pulley side)	Rotation speed (RPM)					Grease quantity (grams)	Bearing type (side opposite pulley)	Rotation speed (RPM)					Grease quantity (grams)
		750	1060	1500	2120	3000			750	1060	1500	2120	3000	
		Relubrication intervals in hours							Relubrication intervals in hours					
SN 507 B-BL	22207 EK	4000	2500	1600	1000	670	6	22207 EK	4000	2500	1600	1000	670	6
SN 508 B-BL	22208 EK	3750	2360	1500	950	600	7	22208 EK	3750	2360	1500	950	600	7
SN 509 B-BL	22209 EK	3550	2250	1400	900	560	9	22209 EK	3550	2250	1400	900	560	9
SN 509 C-CR-CS	22209 EK	3550	2250	1400	900	560	9	22209 EK	7100	4500	2800	1800	1120	9
SN 510 B-BL	22210 EK	3350	2120	1320	850	530	11	22210 EK	3350	2120	1320	850	530	11
SN 510 C-CR-CS	22210 EK	3350	2120	1320	850	530	11	22210 EK	6700	4250	2650	1700	1060	11
SN 511 C-CR-CS	22211 EK	3150	2000	1250	800	500	13	22211 EK	6300	4000	2500	1600	1000	13
SN 512 B-BL	22212 EK	3000	1900	1180	750	475	18	22212 EK	3000	1900	1180	750	475	18
SN 512 C-CR-CS	22212 EK	3000	1900	1180	750	475	18	22212 EK	6000	3750	2360	1500	950	18
SN 513 B-BL	22213 EK	2800	1800	1120	710	450	22	22213 EK	2800	1800	1120	710	450	22
SN 513 C-CR-CS	22213 EK	2800	1800	1120	710	450	22	22213 EK	5600	3550	2210	1400	900	22
SN 516 B-BL	22216 EK	2500	1600	1000	630	-	28	22216 EK	2500	1600	1000	630	-	28
SN 516 C-CR-CS	22216 EK	2500	1600	1000	630	-	28	22216 EK	5000	3150	2000	1250	-	28
SN 517 C-CR-CS	22217 EK	2360	1500	950	600	-	32	22217 EK	4750	3000	1900	1180	-	32
SN 518 B-BL	22218 EK	2250	1400	900	560	-	34	22218 EK	2250	1400	900	560	-	34
SN 518 C-CL-CR-CRL-CS-CSL	22218 EK	2250	1400	900	560	-	34	22218 EK	4500	2800	1800	1120	-	34
SN 520 B-BL-C	22220 EK	2000	1250	800	-	-	40	22220 EK	2000	1250	800	-	-	40
SN 522 B-BL-C	22222 EK	1800	1120	710	-	-	50	22222 EK	1800	1120	710	-	-	50
SN 524 B-BL-C	22224 EK	1600	1000	630	-	-	60	22224 EK	1600	1000	630	-	-	60
SN 526 C	22226 EK	1500	950	600	-	-	70	22226 EK	1500	950	600	-	-	70
SN 528 B-BL-C	22228 CCK/W33	1320	850	-	-	-	80	22228 CCK/W33	1320	850	-	-	-	80
SN 530 C	22230 CCK/W33	1180	750	-	-	-	90	22230 CCK/W33	1180	750	-	-	-	90

NOTES:
 Relubrication intervals calculated on basis of diagram taken from maintenance manual for SKF bearings, with temperature on the outer ring of 70°C.
 Quantity of grease in grams calculated according to SKF standards.

Chart 8-2 Relubrication intervals and quantity of grease according to fan rotation speed

8.2 Checking spherical roller bearings

Before fitting the bearing, the internal radial clearance above the roller located in the highest position must be checked with a feeler gauge (see Fig. 8-1 Checking radial clearance on bearings).

During fitting, check the reduction of internal clearance beneath the lowest roller several times.

Correct fitting is obtained with a reduction of internal clearance and minimum residual clearance corresponding to the indications given in Chart 8-3 Checking radial clearance on bearings

Roller bearing	Radial clearance reduction (mm)	Minimum residual clearance after fitting (mm)	
		Normal clearance	C3 clearance
22209 EK	from 0.025 to 0.030	0.020	0.030
22210 EK	from 0.025 to 0.030	0.020	0.030
22212 EK	from 0.030 to 0.040	0.025	0.035
22214 EK	from 0.040 to 0.050	0.025	0.040
22215 EK	from 0.040 to 0.050	0.025	0.040
22216 EK	from 0.040 to 0.050	0.025	0.040
22218 EK	from 0.045 to 0.060	0.035	0.050
22220 EK	from 0.045 to 0.060	0.035	0.050
22222 EK	from 0.050 to 0.070	0.050	0.065
22224 EK	from 0.050 to 0.070	0.050	0.065
22228 CCK/W33	from 0.065 to 0.090	0.055	0.080
22230 CCK/W33	from 0.075 to 0.100	0.055	0.090

Chart 8-3 Checking radial clearance on bearings

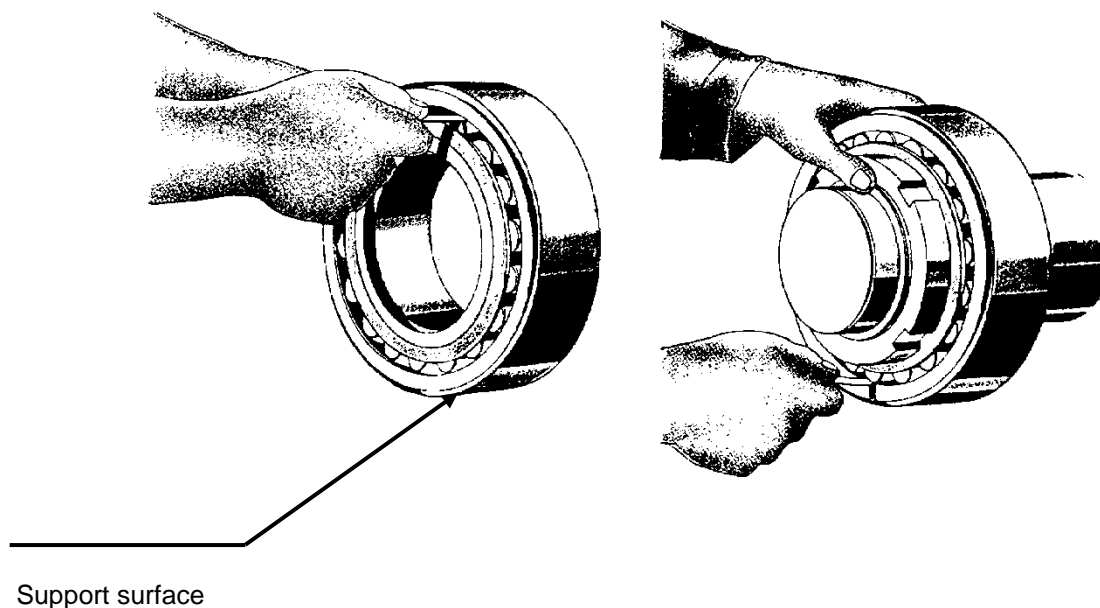

Fig. 8-1 Checking radial clearance on bearings

8.3 Checking self-aligning ball bearings

Correct fitting is obtained with a tightening angle, axial movement and minimum residual clearance corresponding to the indications of Chart 8-4.

Self-aligning ball bearing	Tightening angle (degrees)*	Axial movement s (mm)	Minimum residual clearance after fitting (mm)	
			Normal clearance	C3 clearance
2207 EK	70	0.30	0.010	0.020
2208 EK	70	0.30	0.010	0.020
2209 EK	80	0.35	0.015	0.025
2210 EK	80	0.35	0.015	0.025
2211 EK	75	0.40	0.015	0.030
2212 EK	75	0.40	0.015	0.030
2213 EK	80	0.40	0.015	0.030
2215 EK	85	0.45	0.020	0.040
2216 EK	85	0.45	0.020	0.040
2217 K	110	0.60	0.020	0.040
2218 K	110	0.60	0.020	0.040

- values higher by an average of 15–20° for C3 bearings

Chart 8-4 Tightening angle, axial movement and minimum residual clearance on ball bearings

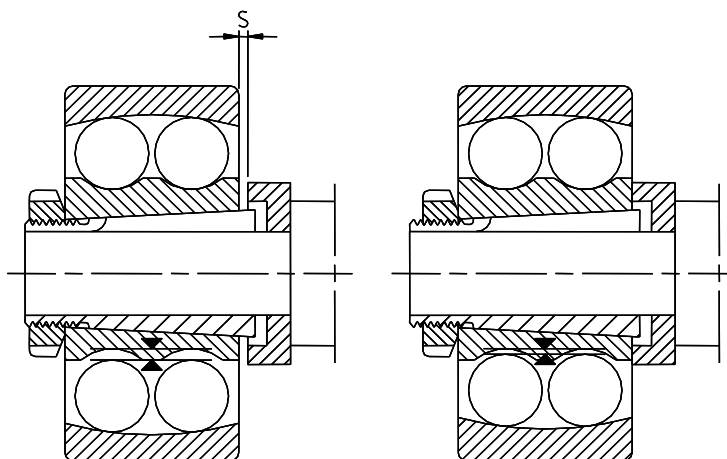

Fig. 8-2 Axial movement s

8.4 Adjusting drive belt tension and cleaning belts

A simplified method for setting the correct tension of V-belts is as follows: Chart 8-5 can be used to obtain the value P of the load for each belt for the profile type and the diameter of the smaller pulley. The value L can also be obtained from the same chart.

Use this formula:
$$L_e = \frac{LxI}{100}$$

to calculate the value L_e , where:

L_e = deflection [in mm] of the section at the centre point of distance I between pulley centres

L = deflection for distance between centres of 100 mm

I = distance between centres [in mm]

Applying load P perpendicularly to the section (Fig. 8-3) the transmission must be tightened until the calculated deflection L_e is reached.

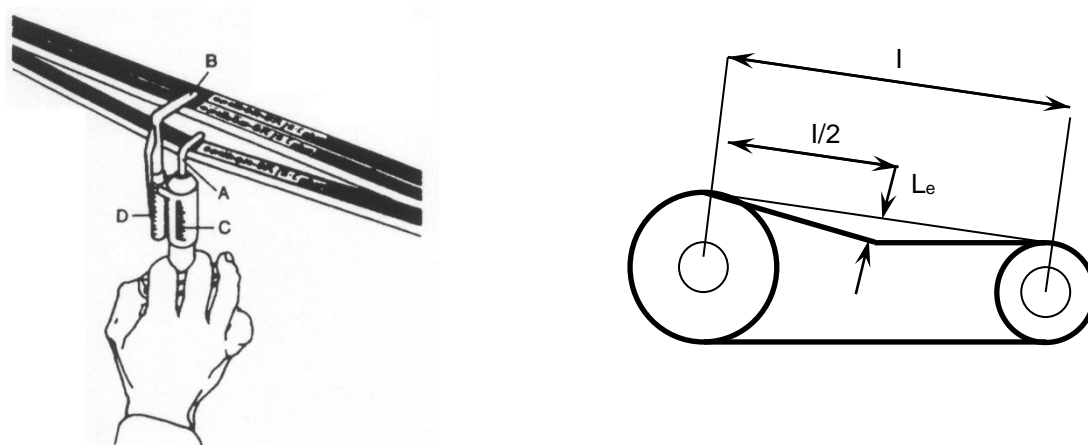

Fig. 8-3 Checking drive belt tension

Profile	Load on belt P [N]	Diameter of smaller pulley d [mm]	Deflection for distance between centres of 100 mm L
SPZ	25	from 63 to 71	2.45
		from 75 to 90	2.20
		from 95 to 125	2.05
		over 125	1.90
SPA	50	from 100 to 140	2.75
		from 150 to 200	2.55
		over 200	2.45
SPB	75	from 160 to 224	2.55
		from 236 to 355	2.22
		over 355	2.10
SPC	125	from 224 to 250	2.55
		from 265 to 355	2.20
		from 400 to 560	2.00
		over 560	1.90

Chart 8-5 Setting drive belt tension: test load and deflection

Check drive belt tension at least after about the first 8 hours of operation, and then follow the indications given for programmed maintenance (see paragraph 12.3).

Completely replace belts when worn to a degree that affects satisfactory operation of the transmission due to an insufficient value of pre-tension or if slipping is more than 4-5%. Belt wear depends on various factors, including environmental factors, the number of operation hours, and the number and type of start-ups.



The manufacturers of standard V-belts recommend that an ambient temperature of 80°C should not be exceeded. For higher temperatures, special belts are necessary.

Dirty belts must not be cleaned with solvents like petrol, benzene, turpentine, etc, or with abrasive or sharp instruments.

It is advisable to use a solution of alcohol and glycerine in a proportion of 1:10. The transmissions installed on **FVI** fans have two or more drive belts.



In the case of breakage of one or more belts, it is advisable to replace the entire set.

8.5 Flexible couplings

According to fan operating conditions, periodic checks should be made on axial play S , angular alignment A_{max} - A_{min} and parallel alignment R (Fig. 8-4, Fig. 8-5, Fig. 8-6). Check the condition of hubs, and lubricate every 3000 hours of operation using the lubricants and quantities recommended (see Chart 8-6).

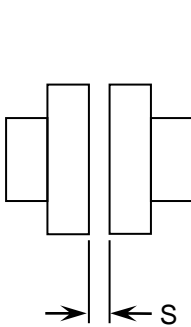

Fig. 8-4 Axial play

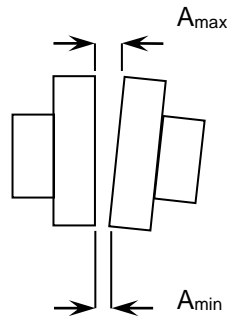

Fig. 8-5 Angular misalignment

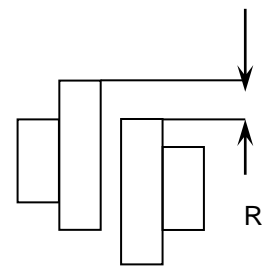

Fig. 8-6 Parallel misalignment

Type	S min [mm]	A _{max} -A _{min} on installation max. [mm]	A _{max} -A _{min} in operation max. [mm]	R max [mm]	Max speed [rpm]	Lubricant [kg]	Recommended lubricant
BT4	2	0.15	0.15	0.15	5000	-	No lubrication required
BT6	2	0.20	0.20	0.20	5000	-	
BT10	2	0.20	0.20	0.20	5000	-	
BT15	2	0.20	0.20	0.20	5000	-	
BT22	2	0.20	0.20	0.20	5000	-	
BT30	2	0.25	0.25	0.25	5000	-	
BT40	2	0.25	0.25	0.25	5000	-	
BT55	2	0.30	0.30	0.30	4900	-	
BT85	2	0.30	0.30	0.30	4300	-	
BT135	2	0.35	0.35	0.35	3700	-	
BT200	2	0.40	0.40	0.40	3400	-	
BT300	3	0.45	0.45	0.45	3000	-	
1020/2020	5.33	0.08	0.25	0.30	4500	0.027	Agip FI FIN 360 Amoco Amolith grease # 2 Chevron USA Chevron Dura-Lith EP2 Gulf Gulf crown grease # 2 Esso Italia Shield 2500 Mobil Mobilux EP 11 Shell Italia Cardium Compound Texaco Starplex HD 2 Valvoline Val-Lith EP
1030/2030	5.03	0.08	0.30	0.30	4500	0.04	
1040/2040	5.36	0.08	0.33	0.30	4500	0.054	
1050/2050	5.38	0.10	0.41	0.41	4500	0.073	
1060/2060	6.55	0.13	0.46	0.41	4350	0.090	
1070/2070	6.58	0.13	0.51	0.41	4125	0.110	
1080/2080	7.32	0.15	0.61	0.41	3600	0.170	
1090/2090	7.26	0.18	0.71	0.41	3600	0.25	
1100/2100	10.9	0.20	0.84	0.51	2440	0.430	
1110/2110	10.9	0.23	0.91	0.51	2250	0.510	
1120/2120	14.2	0.25	1.02	0.56	2025	0.740	
1130/2130	14	0.30	1.19	0.56	1800	0.910	
1140/2140	15.5	0.33	1.35	0.56	1650	1.140	

* The data indicated in charts contained in this manual are taken directly from the technical catalogues of the respective manufacturers.

Chart 8-6 Technical characteristics of flexible couplings

8.6 Filters and pressure gauges

If the fan is fitted with filters for the intake fluid, these must be periodically cleaned so as to prevent increases of load loss at the intake, which would reduce fan performance.

Checks and any necessary cleaning operations must be carried out at predetermined intervals. It is however advisable to use a differential pressure gauge to monitor the pressure gap caused by the filter. This gap must be no more than 400 Pa.



CAUTION:

Do not exceed the pressure value of 400 Pa, to avoid causing possible damage to the filter and the consequent sucking in of filter materials by the fan.

8.7 Flexible anti-vibration joints between the fan and ducting

Flexible joints located between the fan and exit and/or intake ducting must be checked visually to ensure that they are undamaged and that no flexible components have become detached. If these joints must be dismantled for maintenance of the system and/or the fan, they must be reassembled taking the precautions indicated for the first assembly/installation (see paragraph 5.5).

8.8 Checking and cleaning parts in contact with fluids

Periodic impeller cleaning makes it possible to avoid vibrations caused by any dust deposits that accumulate during fan operation.



If the fan is to be used to move fluids that are even slightly dusty, the impeller must be checked periodically for cleanness and/or wear.

Deposits of material or wear on some impeller parts can produce abnormal fan vibrations.

If there are parts that are excessively worn, it is essential to replace the impeller (for this operation contact the **FVI** Technical Service).



*For all information and for any modifications to be made on our products, please contact the **FVI** technical office in advance, specifying the machine type and serial number given on the fan identification plate.*

9 TECHNICAL CHARTS

9.1 ST supports versions A – AL – B - BL

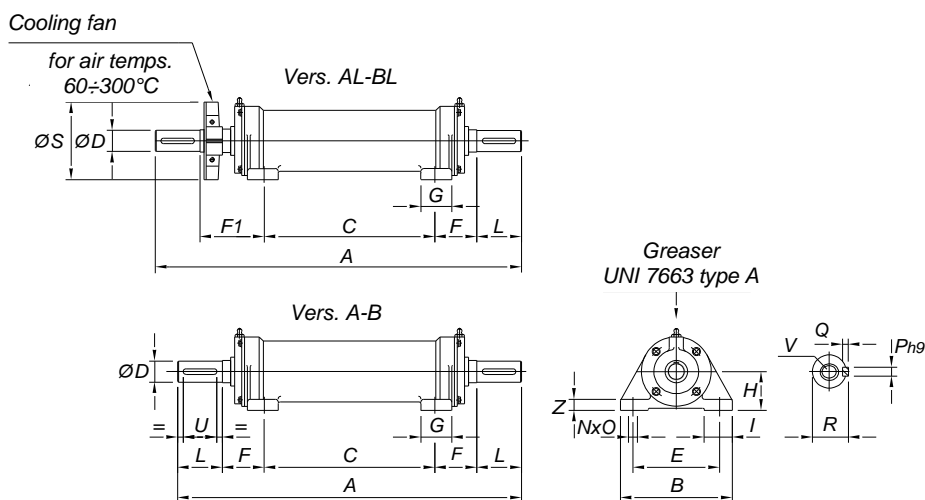

Fig. 9-1 ST supports versions A – AL – B - BL

SUPPORT TYPE	DIMENSIONS in mm																	WEIGHT Kg	
	A	B	C	D J6	E	F	F1	G	H	I	L	NxO	PxQ	R	S	U	V		Z
ST 47 A ST 47 AL	342 369	135	161	19	100	50.5	77.5	40	40	37.5	40	10x15	6x6	21.5	112	30	M6	16	5 5.05
ST 62 A ST 62 AL	422 454	160	210	24	125	56	88	45	55	40	50	13x18	8x7	27	112	40	M8	18	9.6 9.7
ST 80 A ST 80 AL	575 615	200	308	28	155	73.5	113.5	55	70	50	60	15x20	8x7	31	140	50	M10	21	18 18.3
ST 90 A-B ST 90 AL-BL	615 655	200	308	38	155	73.5	113.5	55	70	50	80	15x20	10x8	41	140	60	M12	21	20 20.4
ST 100 A-B ST 100 AL-BL	753 793	230	378	42	175	77.5	117.5	65	80	60	110	18x25	12x8	45	160	80	M16	24	33 33.5
ST 110 A-B ST 110 AL-BL	753 793	230	378	48	175	77.5	117.5	65	80	60	110	18x25	14x9	51.5	160	80	M16	24	34 34.6
ST 120 A-B ST 120 AL-BL	823 883	260	423	48	200	90	150	80	95	65	110	20x30	14x9	51.5	200	90	M16	26	53 54
ST 130 A-B ST 130 AL-BL	823 883	260	423	55	200	90	150	80	95	65	110	20x30	16x10	59	200	90	M20	26	54 55.3
ST 150 A-B ST 150 AL-BL	974 1034	290	470	65	210	112	172	90	105	80	140	22x35	18x11	69	250	120	M20	27	100 101.8
ST 180 A-B ST 180 AL-BL	1095 1165	340	520	80	260	117.5	187.5	90	125	100	170	25x35	22x14	85	315	140	M20	32	150 153
ST 200 A-B ST 200 AL-BL	1164 1234	370	564	90	290	130	200	100	140	105	170	25x35	25x14	95	315	140	M20	35	260 264

* CONSTRUCTION VERSIONS

Version A: short shaft, ball bearings. -- Version AL: long shaft, ball bearings.

Version B: short shaft, ball bearing on impeller side, roller bearing on transmission side.

Version BL long shaft, ball bearing on impeller side, roller bearing on transmission side.

Chart 9-1 ST supports versions A – AL – B - BL





9.2 Standard supports and bearings installed on fans with transmission

SUPPORT	BEARINGS for EF series (cannot be greased)	BEARINGS for EB series	SIZE
ST 47 A 19	6204-2RSH	6204-Z (clearance C3)	314/I 354/H 404/G 454/H
ST 62 A 24	6305-2RS1	6305-Z (clearance C3)	504/G 564/H
ST 80 A 28	6307-2RS1	6307-Z (clearance C3)	634/G 714/H
ST 90 A38	6308-2RS1	6308-Z (clearance C3)	804/G 904/I 904/H
ST 100 A 42	6309-2RS1	6309-Z (clearance C3)	1004/H 1004/K
ST 110 A 48	6310-2RS1	6310-Z (clearance C3)	1124/G 1124/H
ST 120 A 48	6311-2RS1	6311-Z (clearance C3)	1255/F 1254/H
ST 130 A 55	6312-2RS1	6312-Z (clearance C3)	1406/E 1404/H
ST 150 A 65	6314-2RS1	6314-Z (clearance C3)	1604/H
ST 180 A 80	6317-2RS1	6317-Z (clearance C3)	1804/H
ST 200 A 90	6319-2RS1	6319-Z (clearance C3)	2004/H

Chart 9-2 Standard supports and bearings installed on belt-driven fans

10 DISMANTLING AND REASSEMBLING ESSENTIAL COMPONENTS

	<p>CAUTION:</p> <p><i>All dismantling and reassembly operations indicated below must be carried out only by qualified and authorized personnel, equipped with the necessary PPE.</i></p>
---	---

	<p>CAUTION:</p> <p><i>All dismantling and reassembly operations described below must be carried out:</i></p> <ul style="list-style-type: none"> • <i>With the absolute certainty that the fan is at a complete standstill (impeller stationary); disconnect the power supply to the main control panel with the power switch and apply a lock with key to be consigned to the person responsible for maintenance.</i> • <i>After having created a work environment with all necessary equipment and free from all other activities that could dangerously interfere with dismantling and reassembly operations.</i> • <i>After carefully cleaning, degreasing or lubricating, according to use, all components dismantled and reassembled.</i>
---	--

10.1 Fan impellers with steel hub

	<p>CAUTION:</p> <p><i>The impeller must be moved with care, avoiding impacts that could alter its balance or deform it.</i></p>
---	--

	<p>CAUTION:</p> <p><i>For impellers with steel hub featuring cylindrical hole and without tapered bush, mounting/dismounting operations are the same used for impellers with aluminium hub featuring threaded extraction holes (par. 10.2.1 and 10.2.2).</i></p>
---	---

10.1.1 Assembling impeller

1.- Position the impeller (1) near the motor (2), already bolted to the base but not tightened (Photo 1): keeping the impeller raised with suitable lifting equipment (3) (Photo 2), move it towards the motor and fit the motor shaft (4) into the tapered hole in the hub (5) (Photo 3), checking that the pressed part of the hub is on the opposite side to the motor.

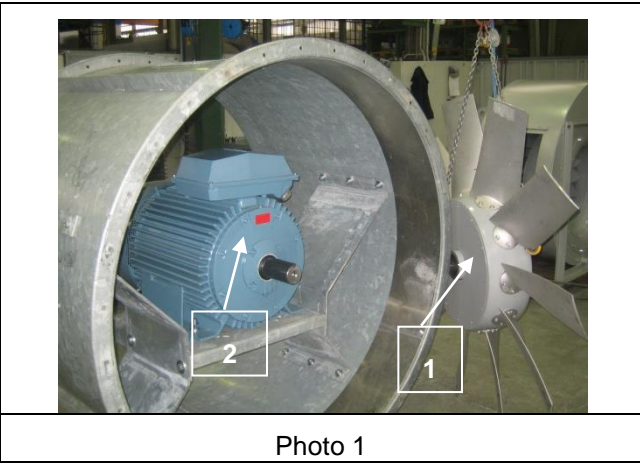

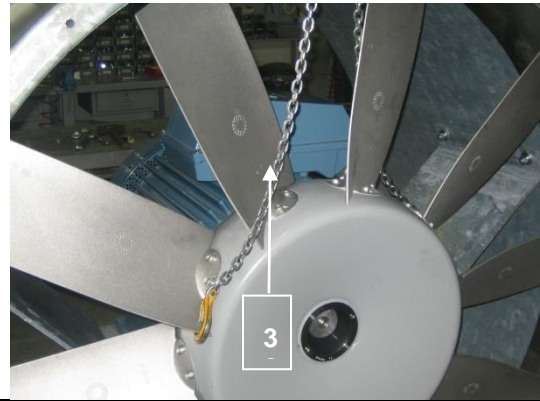

Photo 2

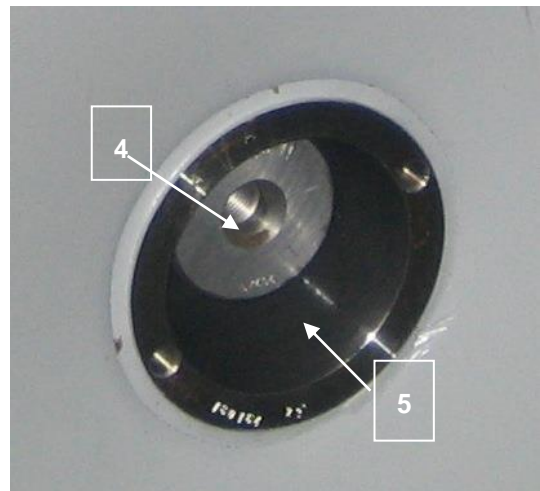

Photo 3

2.- Fit the tapered bush (6) between the impeller hole and the motor shaft (Photo 4): given that the hub hole and the external bush surface are tapered (the smaller diameter is on the motor side), the bush can be fitted only in one direction. To make this operation easier, widen the bush hole by inserting a suitable tool (7) into the bush slit (Photo 5).

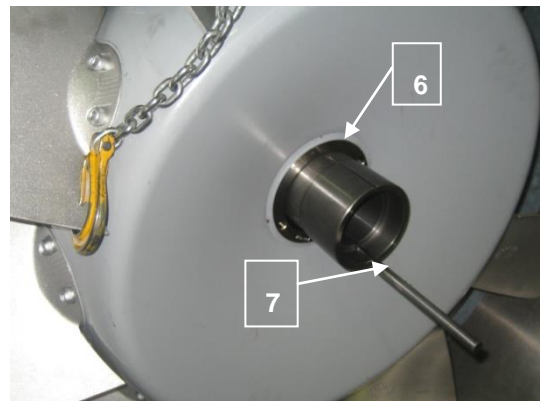

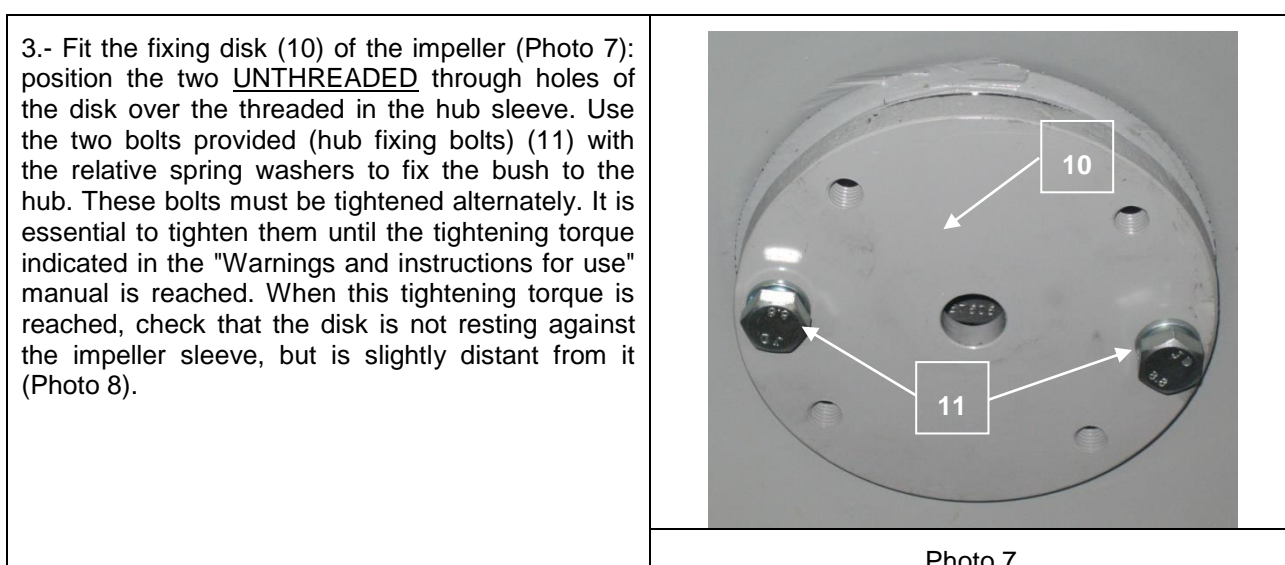
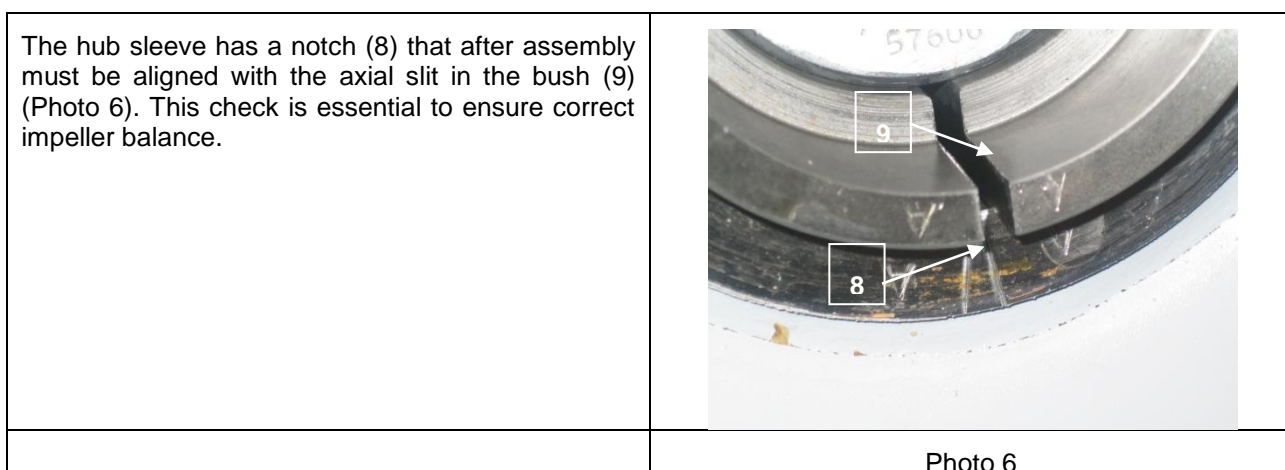
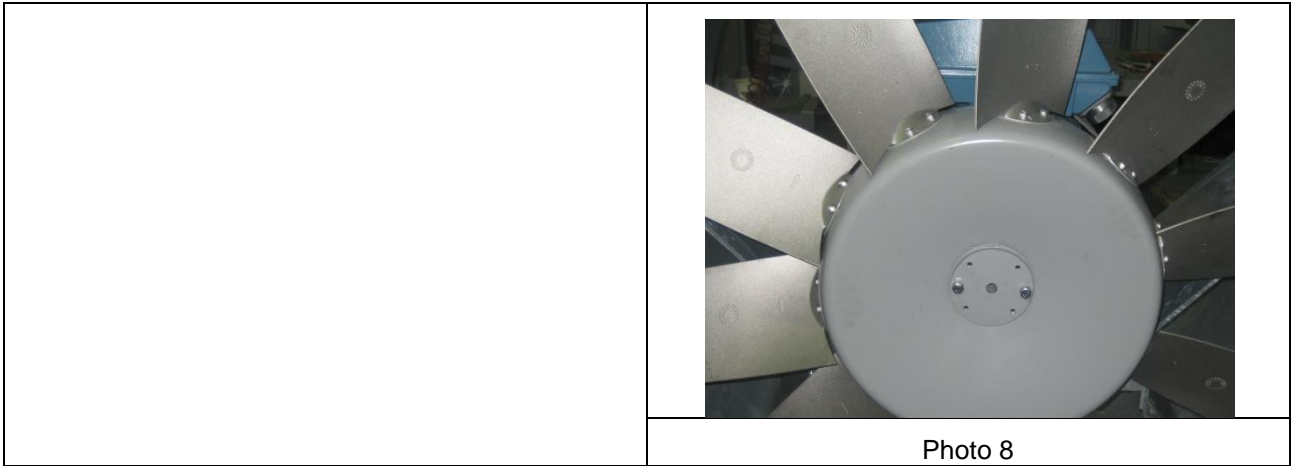

Photo 4



	<p>CAUTION: <i>Ensure that the bush is pushed home until it rests against the stop on the motor shaft.</i></p>
---	--





<p>4.- Fix the central bolt onto the motor shaft: fit the impeller fixing screw (12) with relative spring washer into the central unthreaded hole in the disk and fix it onto the motor shaft (Photo 9). Tighten the bolt until the tightening torque indicated in Chart 12.1 is reached.</p> <p>Note that the 4 threaded holes on the disk are not used. These holes are used only when the impeller is dismantled.</p>	
	Photo 9

<p>5.- Check clearance between the impeller and the casing: after assembly has been completed, check that the impeller is correctly centred with respect to the casing. If necessary, move the motor or adjust the motor base. When the impeller has been centred, tighten all fixing bolts of the base and the motor, respecting the tightening torque values indicated in Chart 12.1.</p>	
---	--

10.1.2 Dismantling impeller

1.- Unscrew the two hub fixing bolts (Photo 10).



Photo 10

2.- Removing the impeller: for this operation, use the two fixing bolts of the hub just dismantled (two additional identical bolts can also be used if available). Screw these bolts alternately into the 4 threaded holes in the disk. When these bolts are screwed in, the impeller is pushed towards the motor, detaching itself from the bush. For this operation, the central bolt (impeller fixing bolt) is still screwed in (Photos 11, 12 and 13).



Photo 11



Photo 12



Photo 13

3.- Secure the impeller with suitable lifting equipment (Photo 14).



Photo 14

4.- Unscrew the impeller fixing bolt and remove the disk (Photos 15 and 16).



Photo 15



Photo 16

5.- Extract the bush (Photo 17): to make this operation easier, insert a suitable tool into the bush slit.



Photo 17

6.- Lift and remove the impeller (Photo 18): when carrying out this operation, take care not to damage or deform the impeller blades.



Photo 18

10.1.3 Adjusting blade angle

Blade angle adjustments may alter impeller balance. It is therefore advisable to check impeller balance after adjusting blade angles, to prevent any abnormal vibration due to blade angle adjustment. Note that an increase in blade angle also produces higher power absorption by the fan.



CAUTION:

Check that the available installed power has not been exceeded by checking power absorption while running, and consult the data on fan characteristics to assess the permitted variation.

This operation can be carried out with the impeller still fitted to the fan. Without removing them, slacken the four fixing bolts (Fig. 10.1) at the base of each blade. Rotate the blade to alter its angle. The original angle is shown on the blade by a mark on the ring between the base of the blade and the hub. A Model G1 goniometer, if supplied, can be used, or any other instrument for measuring angles. Tighten the four blade fixing bolts in opposite pairs until the tightening torque indicated in 12.2 is reached.

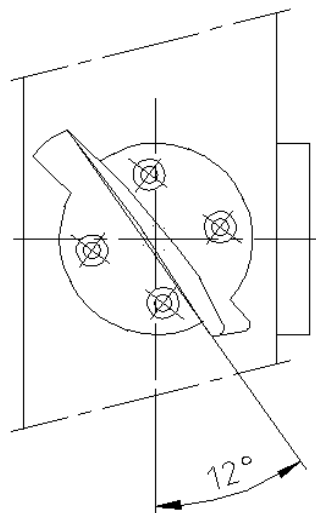



Fig. 10-1 Blade angle adjustment for impellers with steel hubs.

10.2 Fan impellers with aluminium hub

	<p>CAUTION: <i>The impeller must be moved with care, avoiding impacts that could alter its balance or deform it.</i></p>
---	--

10.2.1 Assembling impeller

	<p>CAUTION: <i>The impeller hub may have a circumferential extraction groove (Fig. 10-2) or threaded extraction holes (Fig. 10-3).</i></p>
---	--

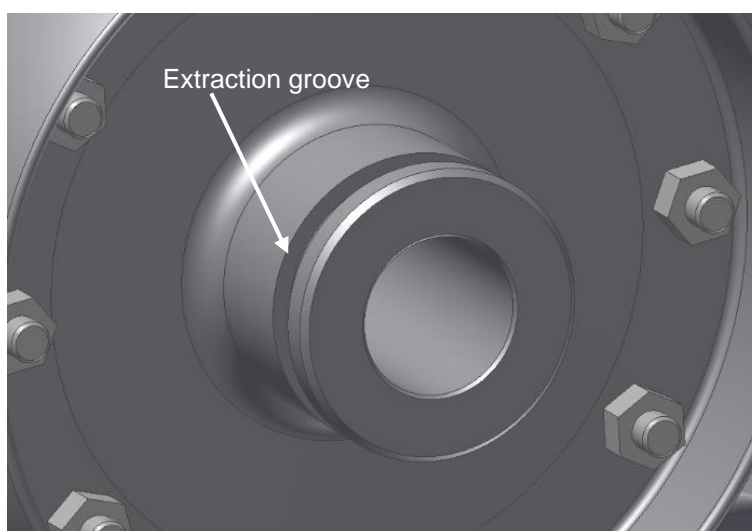

Fig. 10-2 Hub with extraction groove

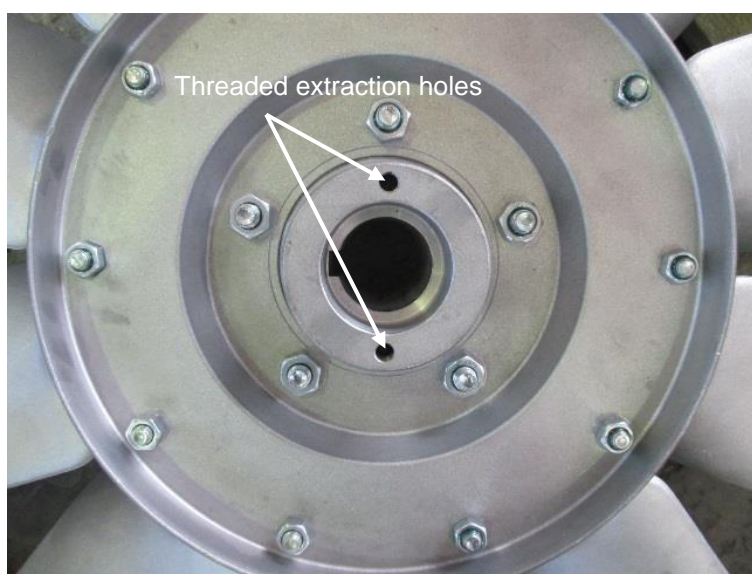

Fig. 10-3 Hub with threaded extraction holes

1.- If necessary, reduce the diameter of the motor shaft until its nominal size is reached with a tolerance of $+0/+5$ microns. Keeping the impeller raised with suitable lifting equipment, move it towards the motor and fit the motor shaft (Photo 19) into the hole in the hub bush.

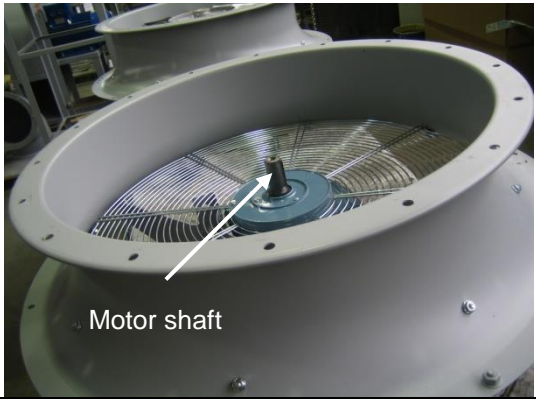

Photo 19

2.- Find the correct angle of rotation that allows the stub on the shaft to fit into the slot in the sleeve (Photo 20), and push the impeller until it fits fully onto the motor shaft. The extraction groove on the hub or the threaded extraction holes must be on the side of the free end of the shaft (Photos 21a and 21b).



Photo 20

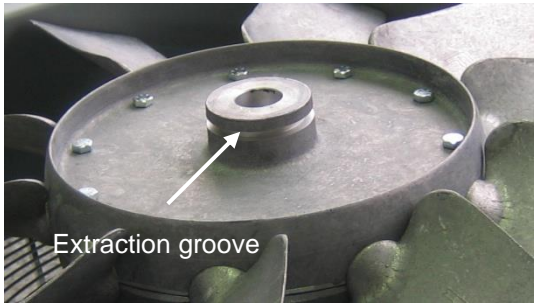

Photo 21a

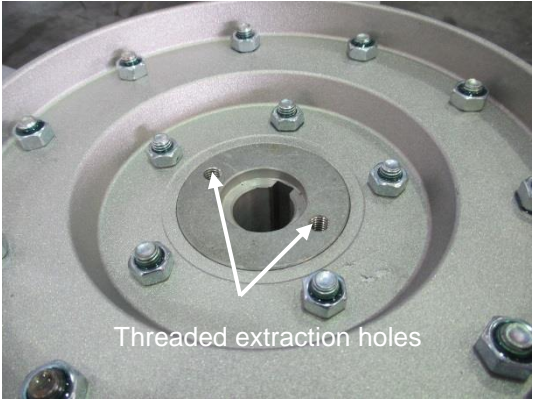

Photo 21b

3.- Fit a threaded rod with washer, spacer and nut into the hole in the impeller sleeve and screw it onto the motor shaft (Photo 22). Use the correct spanner to tighten the nut until the impeller fits into place, resting against the stop on the motor shaft (Photo 23).



Photo 22



Photo 23

4.- Unscrew and remove the threaded rod, washer, spacer and nut (Photo 24).



Photo 24

5.- Fit the impeller fixing bolt and the relative spring washer into the central unthreaded hole of the disk and fix it to the motor shaft (Photo 25).

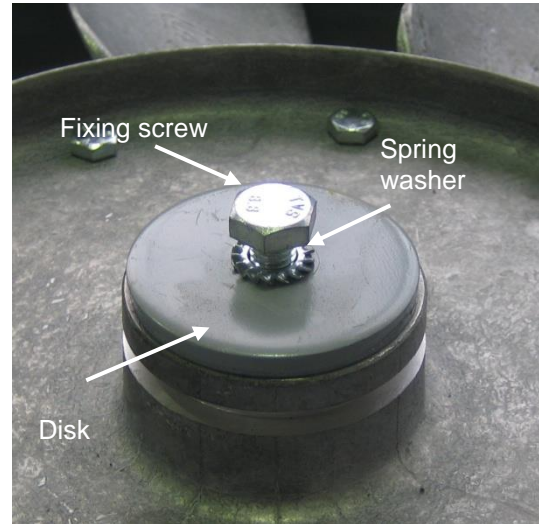

Photo 25

6.- Tighten the bolt until the tightening torque indicated in Chart 12.1 is reached (Photo 26).





Photo 26

7.- Turning the impeller by hand, check that it is correctly centred with respect to the casing. If necessary, move the motor or adjust the motor base. When the impeller has been centred, tighten all fixing bolts of the base and the motor, respecting the tightening torque values indicated in Chart 12.1 (Photo 27).



Photo 27

10.2.2 Dismantling impeller

<p>1.- Support the impeller with suitable lifting equipment.</p>	
<p>2.- <u>Hub with circumferential extraction groove</u>: remove the central impeller fixing bolt (Photo 28). <u>Hub with threaded extraction holes</u>: partially unscrew the central fixing bolt.</p>	 <p style="text-align: center;">Photo 28</p>
<p>3.- <u>Hub with circumferential extraction groove</u>: position the tip of the threaded rod of the extractor and hook the grips onto the extraction groove of the impeller hub (Photo 29a). <u>Hub with threaded extraction holes</u>: screw the peripheral bolts into the threaded holes on the hub and rest the tip of threaded rod of the extractor on the head of the impeller fixing bolt (Photo 29b).</p>	 <p style="text-align: center;">Photo 29a</p>
	 <p style="text-align: center;">Photo 29b</p>

<p>4.- On both hub types, turn the extractor handle to detach the impeller (Photo 30 – for reasons of simplicity only the impeller with an extraction groove is shown).</p>	
<p>5.- Lift and remove the impeller, after removing the fixing bolts in the case of the hub with threaded extraction holes.</p>	<p style="text-align: center;">Photo 30</p>

10.2.3 Adjusting blade angle

Blade angle adjustments may alter impeller balance. It is therefore advisable to check impeller balance after adjusting blade angles, to prevent any abnormal vibration due to blade angle adjustment. Note that an increase in blade angle also produces higher power absorption by the fan.

	<p>CAUTION: <i>Check that the available installed power has not been exceeded by checking power absorption while running, and consult the data on fan characteristics to assess the permitted variation.</i></p>
--	--

To facilitate this operation, the impeller must be removed from the shaft on which it is mounted (see previous paragraphs 10.2.1 and 10.2.2).

<p>Without removing them, slacken nuts 2 on the hub assembly. Rotate the blades to adjust blade angle as desired. Check that all blades are at the same angle. Tighten fixing nuts 2 (Photo 31) on the hub assembly until the tightening torque indicated in Chart 10.1 for bolts with class 8.8 resistance is reached, and then use a thread locking compound.</p>	
	<p style="text-align: center;">Photo 31</p>

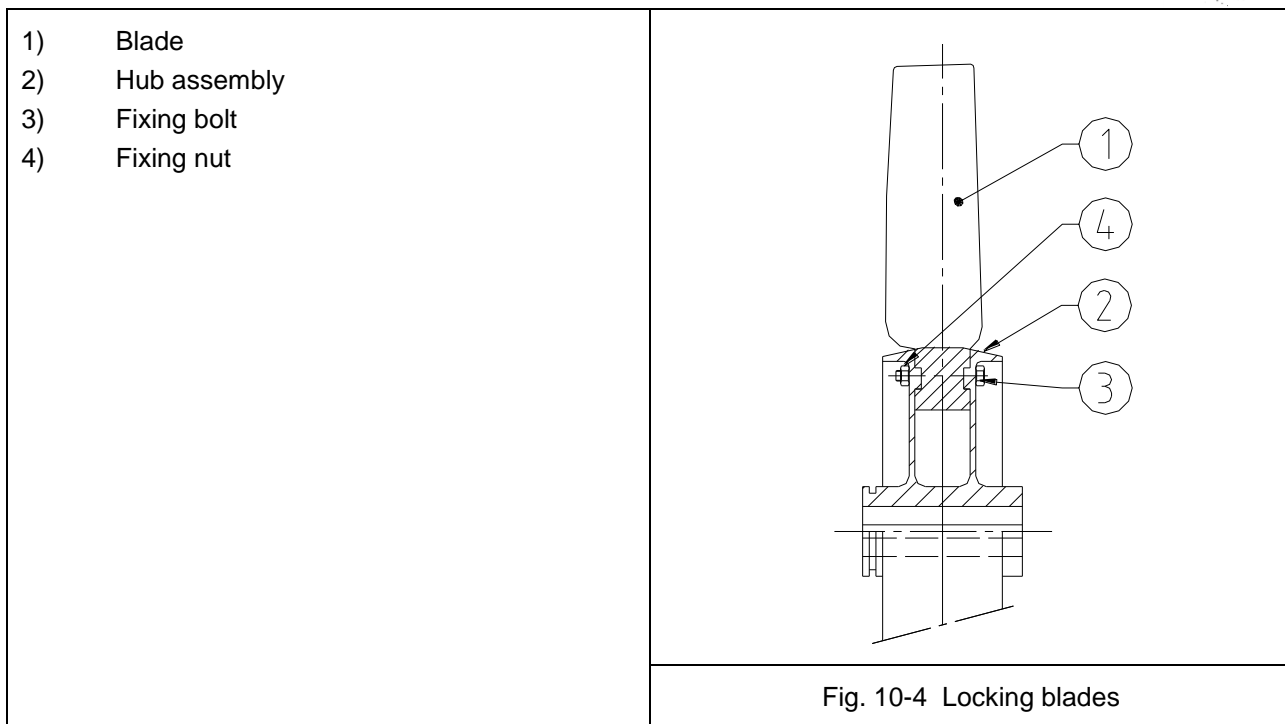

10.3 Replacing drive belts

10.3.1 Assembling and dismantling pulleys

<p>1.- Check that the motor shaft and the transmission shaft are parallel.</p>	
<p>2.- Before fitting the bush (Photo 32) into the pulley, carefully clean tapered parts and the bush hole.</p>	
<p>Photo 32</p>	

3.- Fit the bush into the hole in the pulley, taking care to align the threaded half-holes on the pulley with the unthreaded half-holes on the bush (Photo 32). There may be 2 or 3 of these holes (Fig. 10-5), as can also be seen in Chart 9.1, depending on pulley size.

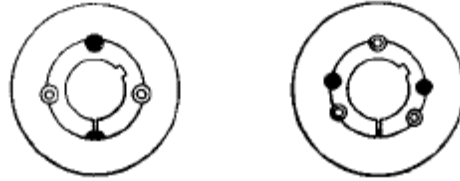

Fig. 10-5 Pulley holes

4.- Screw in the grub screws by hand without fully tightening them (Photo 33).

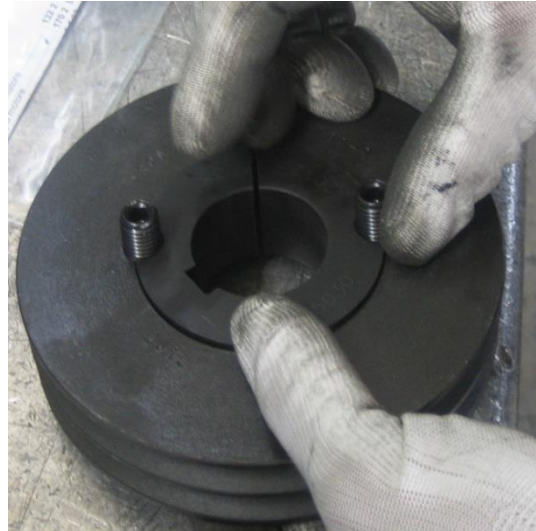

Photo 33

5.- Check that the shaft surface is totally clean, and insert the fixing spline into its slot (Photo 34).



Photo 34

6.- Fit the assembled bush, grub screws and pulley onto the motor shaft with the spline inserted in the corresponding slot in the bush hole. If necessary, widen the bush hole by inserting a suitable tool into the bush slit (Photos 35 and 36).



Photo 35

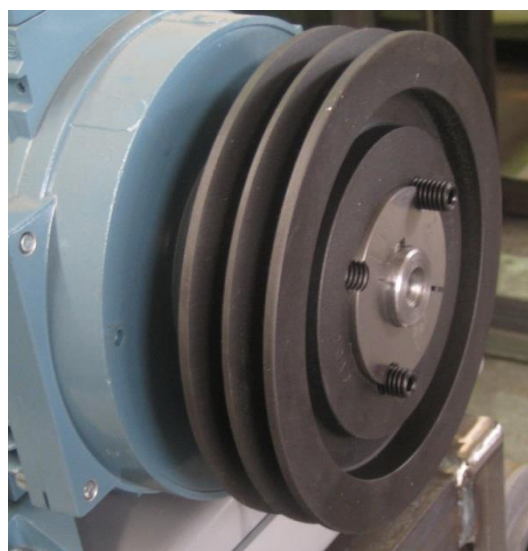

Photo 36

7.- Always check that there is a minimum of clearance between the spline and the corresponding slot (Photo 37).

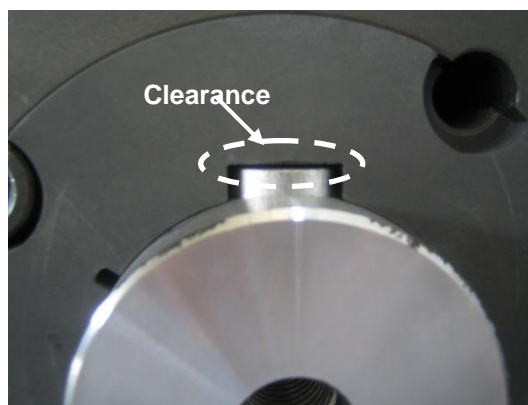

Photo 37

8.- Repeat operations 2 to 7 to fit the pulley onto the transmission shaft.

9.- Use a straight edge of a suitable length to check correct alignment of the pulleys (Photo 38). Use a rubber hammer to move pulleys axially until the parallel misalignment has been corrected (Photo 39).



Photo 38

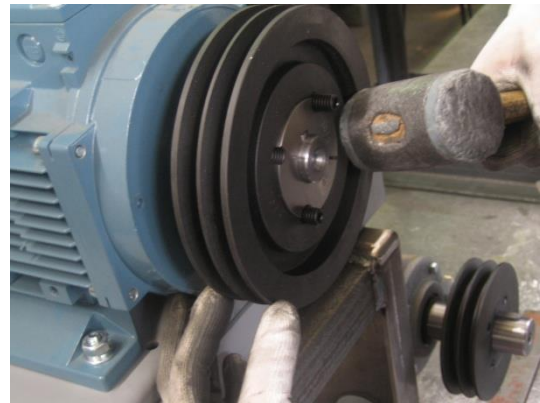

Photo 39

10.- Adjust motor position to correct misalignment (Figs. 10-6 and 10-7).

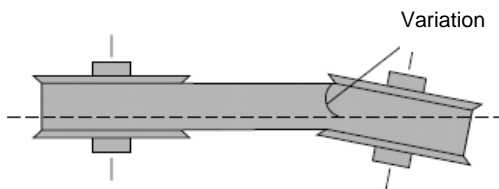

Fig. 10-6 Angular misalignment

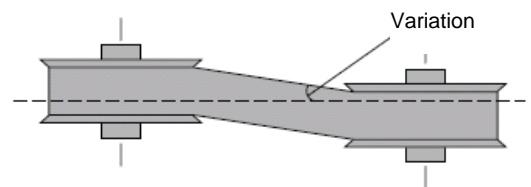



Fig. 10-7 Parallel misalignment

11.- Tighten the pulley grub screws alternately (Photo 40) until the tightening torque indicated in Chart 10.1 is reached.



Photo 40

12.- Check correct pulley alignment again.	
--	--

	<p>CAUTION:</p> <p><i>Incorrect alignment causes excessive wear and greater friction on drive belts, higher power absorption by the transmission, noise and vibrations that reduce the effective lifespan of the transmission.</i></p>
---	---

Generally, the tolerance in pulley alignment in V-belt drive transmissions may not be greater than 0.5 degrees or 5 mm for each 500 mm of distance between centres (Figs. 10-6 and 10-7).

	<p>CAUTION:</p> <p><i>To remove pulleys, unscrew the grubscrews used to fix them and insert one or two of them in the free holes, screwing them in until the bush is detached.</i></p>
---	---

Type	Bush		Grubscrews				
	Length [mm]	Max. diameter [mm]	N°	Whitworth	Length [mm]	Socket size	Tightening torques [N.m]
1008 (25.20)	22.3	35	2	1/4	13	3	5.5
1108 (28.20)	22.3	38	2	1/4	13	3	5.5
1210 (30.25)	25.4	47	2	3/8	16	5	20
1215 (30.40)	38.1	47	2	3/8	16	5	20
1310 (35.25)	25.4	52	2	3/8	16	5	20
1610 (40.25)	25.4	57	2	3/8	16	5	20
1615 (40.40)	38.1	57	2	3/8	16	5	20
2012 (50.30)	31.8	70	2	7/16	22	5	20
2517 (65.45)	44.5	85	2	1/2	25	6	50
3020 (75.50)	50.8	108	2	5/8	32	8	90
3030 (75.75)	76.2	108	2	5/8	32	8	90
3535 (90.90)	88.9	127	3	1/2	38	10	115
4040 (100.100)	101.6	146	3	5/8	44	14	170
4545 (115.115)	114.3	162	3	3/4	51	14	195
5050 (125.125)	127	178	3	7/8	57	17	275

Chart 10-1 Tightening torques

10.3.2 Assembling and dismantling drive belts

<p>1.- After checking correct pulley alignment, fit the belts. Tools should not be used to force the belts into place on the pulleys (Photos 41, 42 and 43). If necessary, reduce the distance between pulley centres by moving the motor closer.</p>	
<p>Photo 41</p>	
<p>Photo 42</p>	
<p>Photo 43</p>	<p>2.- Check belt tension. For this operation, see paragraph 8.4 of this manual.</p>
<p>3.- If the tension of belts is insufficient, the motor must be moved to tension them correctly.</p>	

For version 9 fans (motor supported on the side of the motor pedestal), use the stays to move the motor base (Photo 44).



Photo 44

For version 12 fans, (with motor resting on base), slightly slacken the motor fixing bolts on the motor base and adjust the stays on the sides to move the motor. Then tighten the motor fixing bolts again (Photo 45).

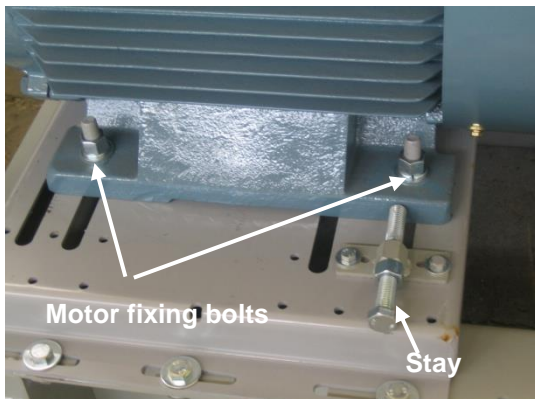

Photo 45

4. Check correct pulley alignment again.

5.- Fit the complete system of transmission protection devices.

	<p>CAUTION: <i>After the first 8 hours of operation, stop the fan and check that pulley assembly screws are still fully tightened.</i></p>
--	--

6.- To remove the drive belts, repeat the previous operations in the reverse order.

10.4 Replacing shaft and bearings on one-piece support

10.4.1 Dismantling shaft on one-piece support



CAUTION:

All the operations described below must be carried out in a perfectly clean environment, also avoiding introducing any source of contamination inside the support.

FVI one-piece supports for fans with transmission (Photo 46) can be of two types, according to the type of bearing fitted on the pulley side or the coupling side (LP transmission side):



Photo 46.- One-piece support.

- Type ST...A... support with rigid ball bearing on transmission side (Fig. 10-8).
- Type ST...B... support with rigid roller bearing on transmission side (Fig. 10-9). The side with the roller bearing is punched with "CR" on the shaft.

Both types of support are fitted with a ball bearing on the impeller side (LG).

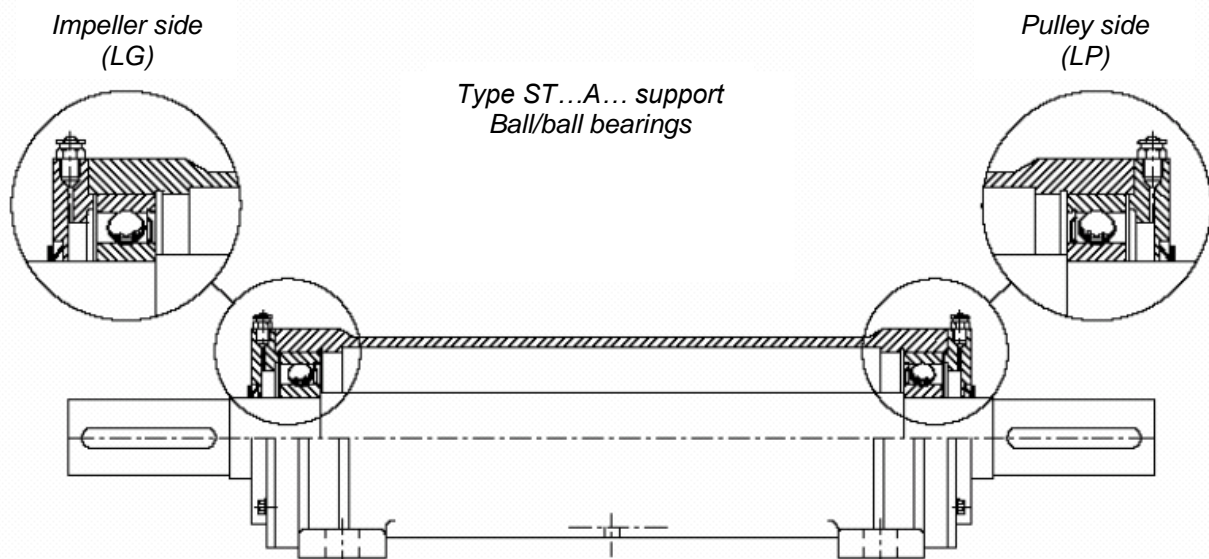

Fig. 10-8 ST...A... one-piece support with radial ball bearings both on impeller side and transmission side

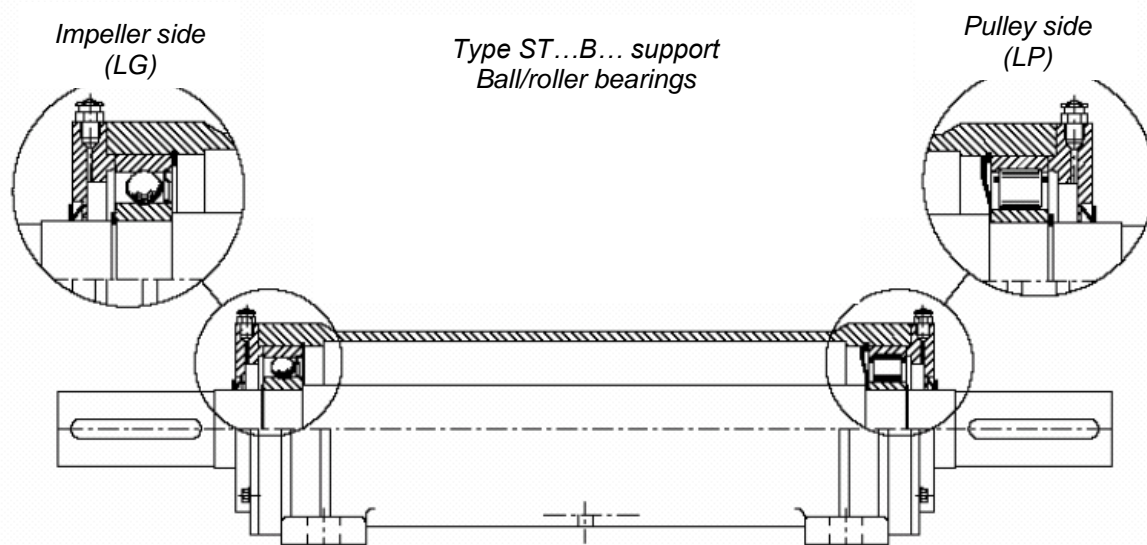

Fig. 10-9 ST...B... one-piece support with radial ball bearings on impeller side and roller bearings on transmission side

On Type ST...B... supports, the shaft must be extracted from the impeller side. On Type ST...A... supports, the shaft can be extracted from both sides. It is however advisable to always extract the shaft from the impeller side, above all when you are not certain of the type of support to be dismantled.

The steps for support shaft dismantling are as follows:

- 1.- For supports with a cooling fan installed, the cooling fan must first be dismantled (Fig. 10-10).

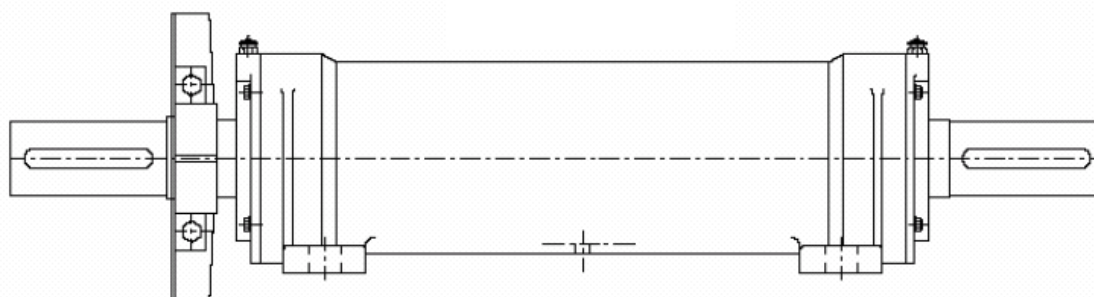

Fig. 10-10 Support with cooling fan

2.- Remove the two VA sealing rings located between the shaft and the two support end covers (Photo 47).

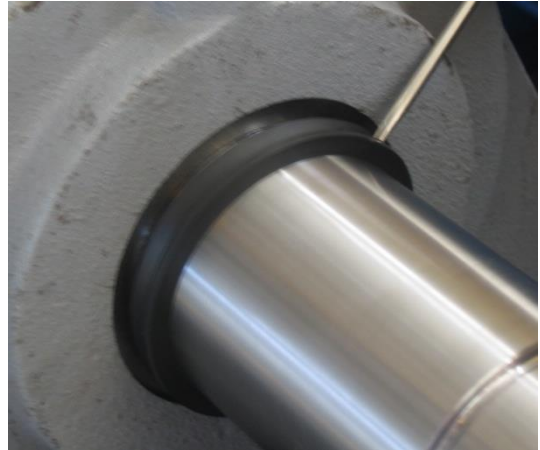

Photo 47

3.- Remove the fixing bolts and the cover on the impeller side (Photo 48).



Photo 48

4.- Extract the shaft.

For Type ST...A... supports, the last operation is to completely remove the shaft. When this is done, the two bearings, both on the impeller side and on the transmission side, are also extracted (Photo 49). To dismantle the radial bearings from the shaft use an extractor.



Photo 49

For Type ST...B... supports, extract the shaft only partially, resting it in an intermediate position (Photo 50).

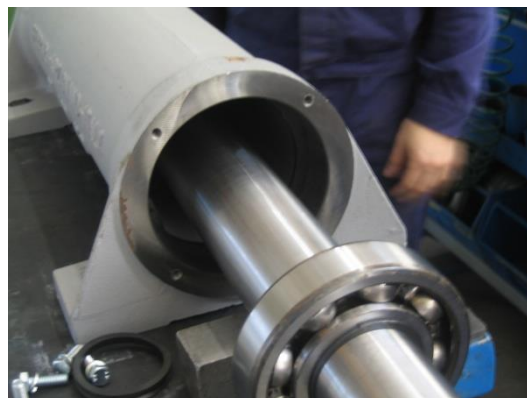

Photo 50

5.- With the shaft still partially inside the support, remove the spring locking ring located in the support from the impeller side, using suitable pliers (Photo 51).



Photo 51

6.- Completely extract the shaft. When this is done, the ball bearing on the impeller side, the spring locking ring that secures the ball bearing to the shaft, the internal roller bearing ring on the transmission side and the spring locking ring that secures the roller bearing to the shaft (if present) are also extracted (Photo 52).

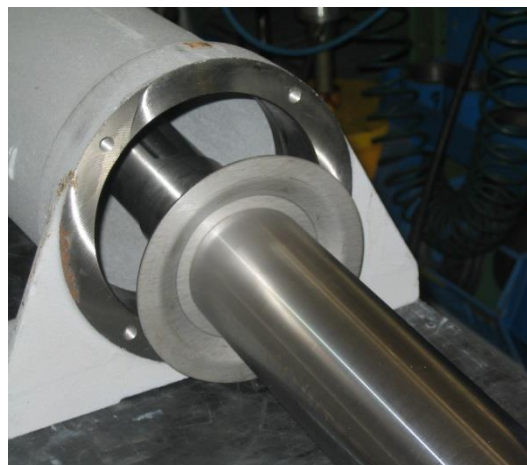

Photo 52

7.- Remove the bolts and the cover on the pulley side (Photo 53).

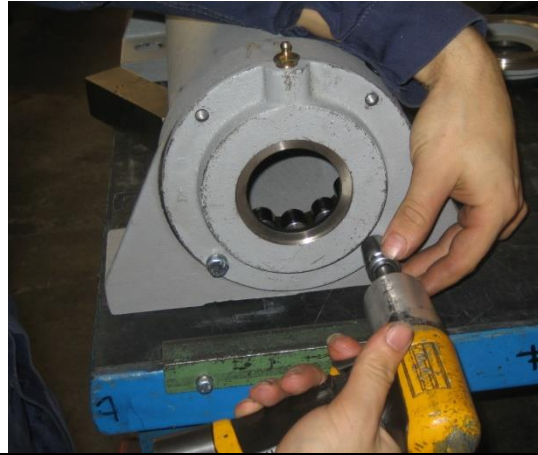

Photo 53

8.- Extract remaining components (casing, rollers and external ring) of the roller bearing (Photo 54).



Photo 54

9.- Remove the spring locking ring located on the transmission side of the support, using suitable pliers (Photo 55).

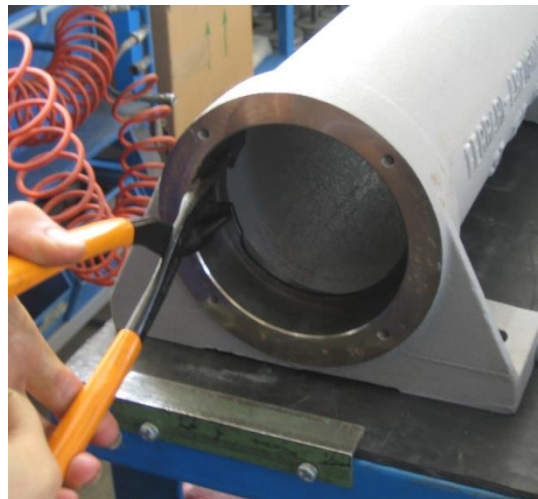



Photo 55

10.4.2 Reassembling shaft on one-piece support

All the operations described below must be carried out in a perfectly clean environment, also avoiding introducing any source of contamination inside the support.

10.4.2.1 Type ST... A... supports

<p>1.- Fit the two ball bearings onto the transmission shaft from both sides (Photo 56). Preheat the internal bearing rings to a temperature of about 70°C before carrying out this operation, or use a press or a hammer.</p>	 <p style="text-align: center;">Photo 56</p>
--	---

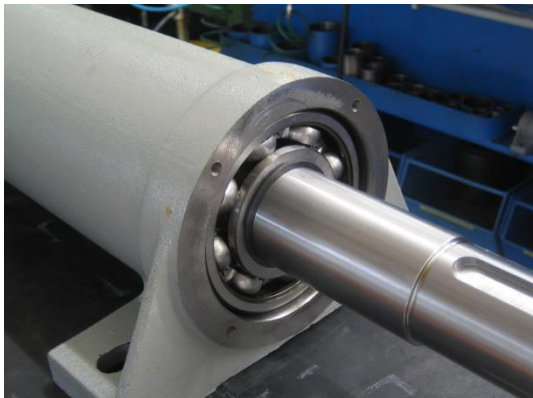
<p>2.- Fully insert the shaft, complete with the two bearings, into the support (Photo 57)</p>	 <p style="text-align: center;">Photo 57</p>
--	--

<p>3.- Grease the bearings using the type of grease recommended in paragraph 8.1, filling the bearing completely but the free space of the housing only partially.</p>	
--	--

4.- Bolt on the covers at both ends of the support (Photo 58).



Photo 58

5.- Insert the two VA sealing rings between the shaft and the support end covers (Photo 59).

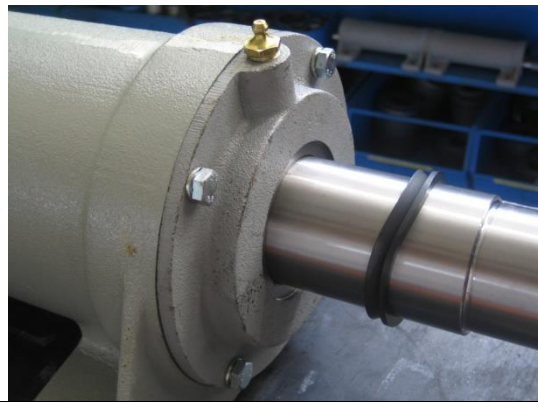

Photo 59

10.4.2.2 Type ST...B... supports

1.- Fit the grease sealing ring up to the stop on the shaft from the transmission side (Photo 55).

Take care to fit the grease sealing ring in the right direction (Fig. 10-9 and Photo 60).



Photo 60

2.- Fit the spring locking ring (to be fixed inside the support) onto the shaft from the impeller side. The ring will be suspended from the shaft, but is not fixed (Photo 61).



Photo 61

3.- Fit the ball bearing onto the shaft from the impeller side, and secure it axially using the spring locking ring (Photo 62).

Preheat the internal bearing ring to a temperature of about 70°C before carrying out this operation, or use a press or a hammer.



Photo 62

4.- Fit the internal ring of the roller bearing onto the shaft from the transmission side, and secure it axially using the spring locking ring (Photo 63). Preheat the internal bearing ring to a temperature of about 70°C before carrying out this operation, or use a press or a hammer.



Photo 63

5.- Fix the spring locking ring into the recess in the support from the transmission side (Photo 64)

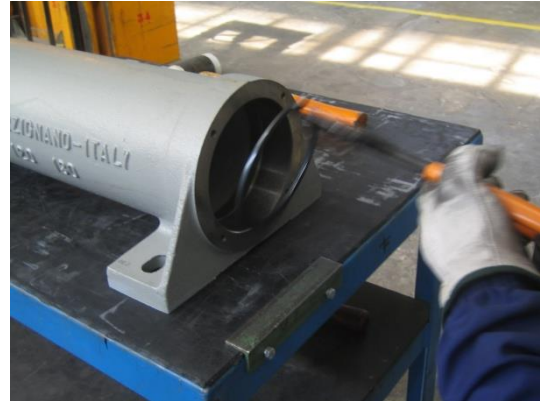

Photo 64

6.- Partially insert the shaft, complete with all components fitted, into the support. The shaft must be fitted from the impeller side, first inserting the end of the shaft with the internal ring of the roller bearing and the grease sealing ring (Photo 65).



Photo 65

7.- Before completely inserting the shaft, rest it in an intermediate position and fix the suspended spring locking ring in the recess on the impeller side of the support (Photo 66).



Photo 66

8.- Fully insert the shaft (Photo 67).

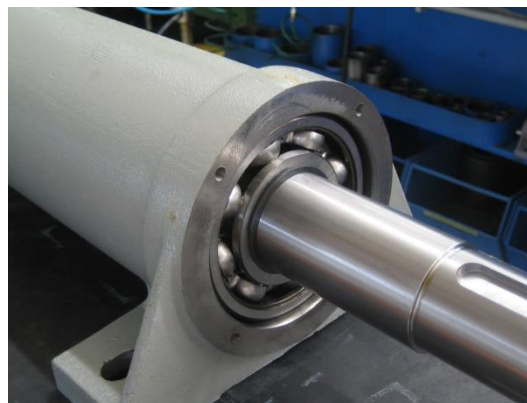

Photo 67

9.- From the transmission side, insert the remaining roller bearing components: casing, rollers and external ring (Photo 68).



Photo 68

10.- Grease the bearings using the type of grease recommended in paragraph 8.1, filling the bearing completely but the free space of the housing only partially (Photo 69).

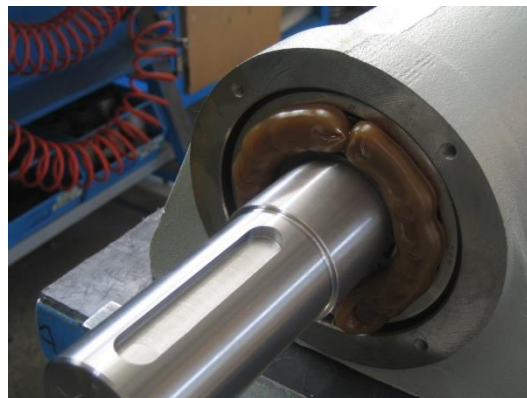

Photo 69

11.- Bolt on the covers at both ends of the support (Photo 70).



Photo 70

12.- Insert the two VA sealing rings between the shaft and the support end covers (Photo 71).

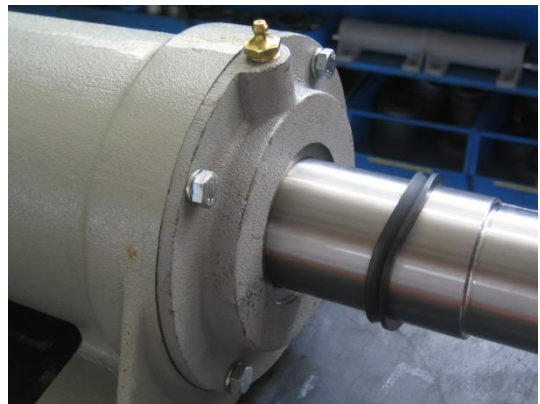



Photo 71

11 FINAL DISMANTLING AND DISPOSAL OF FANS

At the end of the life cycle of the fan, the machine and its accessories must be dismantled as indicated below, so as to allow the various components to be disposed of differently according to the type of material from which they are made. Before demolishing the machine, the user must drain the grease present in bearing supports and generally clean the various components.

	<p>CAUTION:</p> <p><i>Particular attention must be dedicated to the possible presence of residues of toxic and/or corrosive substances left by the fluid moved.</i></p>
---	--

Most of the components (casing, motor pedestal, intake, bearings, guards, pulleys, bushes) are made of metallic materials (steel and cast iron), and can therefore be disposed of together.

Impellers are made from the materials indicated in Chart 11-1.

The electric motor must instead be separated and disposed of at a facility specializing in the elimination of electrical wastes, together with any electric servomotors.

Drive belts are made from rubber, and vibration dampers are also made mainly from the same material.

Most of the accessories are also made from metals, except for anti-vibration joints, constituted by two metallic flanges bolted together and separated by a textile joint in PVC or aluminiumized glass fibre.

Fan dismantling operations can be carried out either in the place of installation, if the need for safe working conditions allows this, or in some other location, after removing and transporting the fan as indicated in Chapter 4 of this manual.

	<p>CAUTION:</p> <p><i>All dismantling operations must be carried out only by qualified and authorized personnel, equipped with the necessary PPE.</i></p>
---	--

	<p>CAUTION:</p> <p><i>All dismantling operations must be carried out</i></p> <ul style="list-style-type: none"> • <i>With the absolute certainty that the fan is at a complete standstill (impeller stationary), after the motor has been disconnected from the electrical power supply by qualified and authorized persons.</i> • <i>After having created a work environment with all necessary equipment and free from all other activities that could dangerously interfere with dismantling operations.</i> •
---	---

	<p><i>Special or specific equipment is not necessary for the dismantling of fan parts.</i></p>
---	--

Dismantling operations can be carried out following the detailed assembly instructions given in Chapter 10 in the reverse order.



CAUTION:

Regardless of the installation type, all components connected to the fan flange must be disconnected and removed before proceeding.

Fan series	Blade material	Hub material	Hub sleeve
EF, ES, EB, EFR, ESR, EQ, EK, ET	Aluminium	Aluminium	-
EF, ES, EB, EFR, ESR ... /H o .../K	Aluminium	Steel	Cast iron
AF	Steel	Steel	-
EP	Plastic	Aluminium	-

Chart 11-1 Component materials of axial impellers

11.1 Version 4 axial fans

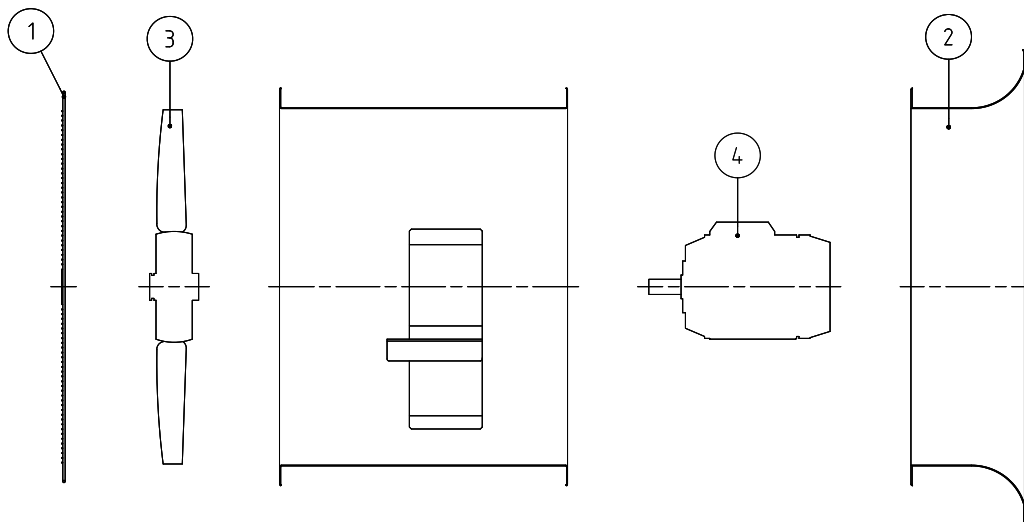

Fig. 11-1 Exploded view of version 4 fan

With reference to Fig. 11-1, the correct dismantling sequence for version 4 fans is as follows:

- Guards (1) (if present)
- Intake (2) (if present)
- Impeller (3) (paragraphs 10.1.2 and 10.2.2)
- Motor (4)

11.2 Version 1-9 axial fans

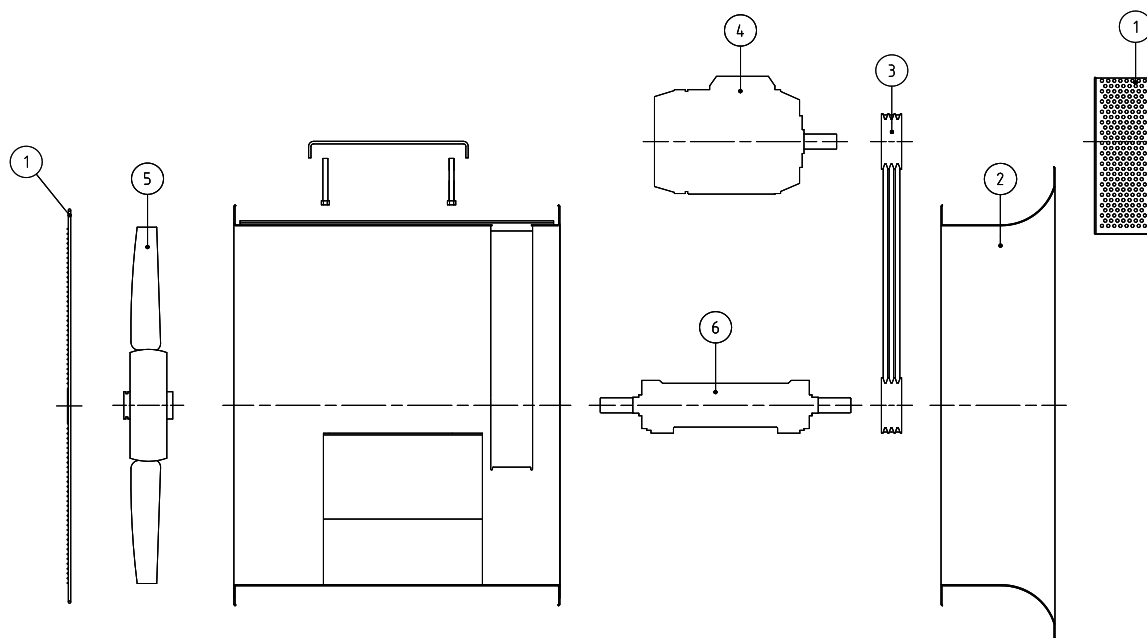

Fig. 11-2 Exploded view of version 9 fan

With reference to Fig. 11-2, the correct dismantling sequence for version 9 fans is as follows:

- Guards (1)
- Intake (2) (if present)
- Transmission components (3) (paragraph 10.3)
- Motor (4)
- Impeller (5) (paragraphs 10.1.2 and 10.2.2)
- Support (6) and cooling fan (if present) (paragraph 10.4.1)
- Seal (if present)

11.3 Version 12 axial fans

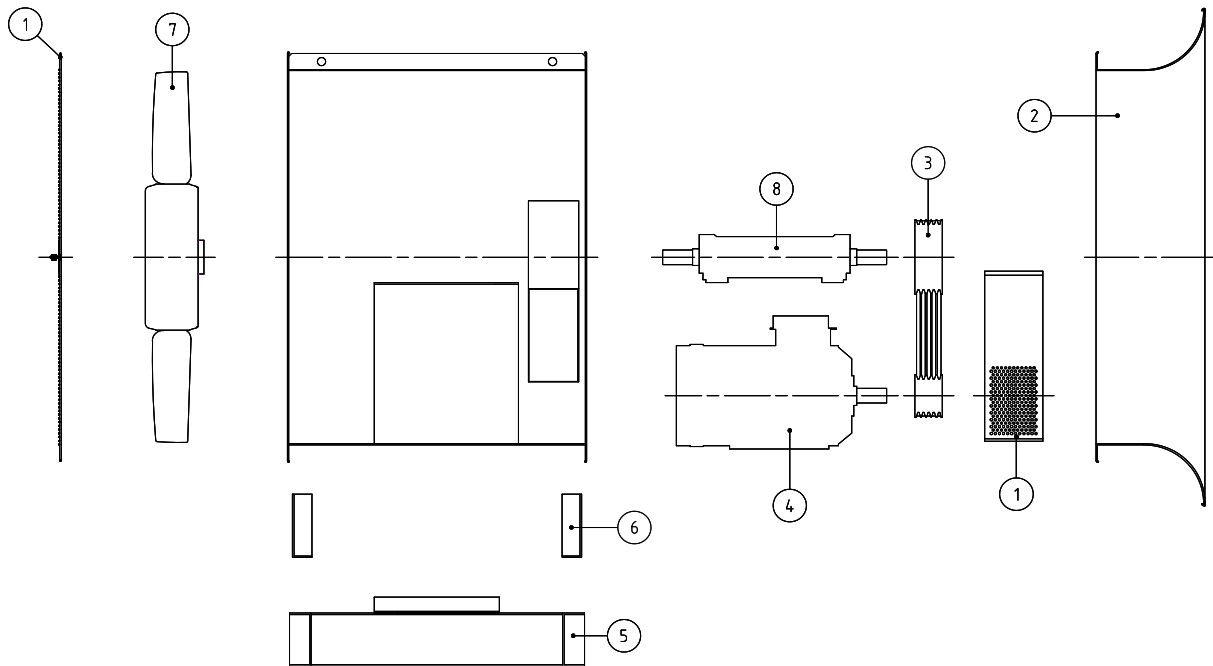

Fig. 11-3 Exploded view of version 12 fan

With reference to Fig. 11-3, the correct dismantling sequence for version 12 fans is as follows:

- Guards (1)
- Intake (2) (if present)
- Transmission components (3) (paragraph 10.3)
- Motor (4)
- Base (5)
- Feet (6)
- Impeller (7) (paragraphs 10.1.2 and 10.2.2)
- Support (8) and cooling fan (if present) (paragraph 10.4.1)
- Seal (if present)

12 TECHNICAL APPENDICES

12.1 Tightening torques for nuts and bolts

Tightening torques M of the chart 12-1 are valid under the following conditions:

- Type UNI 5737 bolts with hexagonal heads, type UNI 5931 and UNI 6107 screws with cylindrical head, in normal conditions of supply.
- Tightening torques are assumed to be applied slowly with a torque wrench.

While maintaining the same pre-stressing values, tightening torques must be varied as follows in these cases:

- increased by 5% for UNI 5712 bolts with extra-wide heads
- reduced by 10% for oiled galvanized bolts
- reduced by 20% for oiled phosphate-treated bolts
- reduced by 10% if bolts are tightened with an impact wrench.

D x pitch mm			Sr mm ²	8.8	10.9	12.9	A2/A4-70	A2/A4-80
				M Nm	M Nm	M Nm	M Nm	M Nm
6	x	1	20,1	10,4	15,3	17,9	8,8	11,8
7	x	1	28,9	17,2	25	30	-	-
8	x	1,25	36,6	25	37	44	21,4	28,7
10	x	1,5	58	50	73	86	44	58
12	x	1,75	84,3	86	127	148	74	100
14	x	2	115	137	201	235	119	159
16	x	2	157	214	314	368	183	245
18	x	2,5	192	306	435	509	260	346
20	x	2,5	245	432	615	719	370	494
22	x	2,5	303	592	843	987	488	650
24	x	3	353	744	1060	1240	608	810
27	x	3	459	1100	1570	1840	-	-
30	x	3,5	561	1500	2130	2500	-	-

Chart 12-1 Tightening torques M for bolts with ISO metric threads



Tightening torques valid for fixing bolts with 12.9 resistance class for aluminium blades on fans with steel hub		
Bolt	Torque (Nm)	Torque must be checked with a torque wrench. Do not use galvanized nuts or bolts.
M8	30	
M10	60	
M12	80	
M16	110	

Chart 12-2 Tightening torques for blade fixing bolts on fans with steel hub

12.2 Checklist before starting fans

The checks listed below are necessary, but could be insufficient in environments with particular types of risk.

CHECKLIST BEFORE STARTING FANS		
CODE	SERIAL NUMBER	YEAR
Identify installation type in accordance with paragraph 3.1.		A <input type="checkbox"/> B <input type="checkbox"/> C <input type="checkbox"/> D <input type="checkbox"/>
Check compatibility of fan with type of application.		OK <input type="checkbox"/>
Check that the fan and motor identification plate data are compatible with the data on the transmission information card (if present).		OK <input type="checkbox"/>
Check the compatibility of the electrical data of the motor identification plate with the electrical power supply (frequency, voltage, connections); for further checks consult the motor instruction manual.		OK <input type="checkbox"/>
Check the efficiency of any power switch installed for the electrical power supply to the motor and any auxiliary circuits (e.g. heaters).		OK <input type="checkbox"/>
Check for absence of foreign bodies inside fan.		OK <input type="checkbox"/>
Check for presence of all nuts, bolts and other fasteners envisaged.		OK <input type="checkbox"/>
Check tightness of nuts and bolts in accordance with Chart 12-1 (impeller, supports, foundations, transmission if present).		OK <input type="checkbox"/>
Check for the efficiency of interblock on access door to room or on safety barriers (if necessary).		OK <input type="checkbox"/>
Check lubrication conditions of bearings (including motor bearings if these can be lubricated)		OK <input type="checkbox"/>
Check alignment of flexible coupling (if present). See paragraph 8.5.		OK <input type="checkbox"/>
Check that all rotating parts can turn freely.		OK <input type="checkbox"/>
Check directions of fan rotation and fluid flow.		OK <input type="checkbox"/>
Check availability of safety procedure for access to fan.		OK <input type="checkbox"/>
Check that personnel have been instructed and trained.		OK <input type="checkbox"/>
Date:		
Signature:		



12.3 Programmed maintenance intervals

The intervals of time suggested constitute a working basis for the customer, who must according to circumstances make any modifications necessary for the specific operating conditions.

Programmed maintenance intervals according to intensity of use				
		Intensity of use		
		High	Medium	Low
For all fans				
1	Check perfect condition of all guards and warning symbols. See paragraph 1.3 and 6.2.1	1 month	1 month	1 month
2	Check correct tightness of all nuts and bolts in accordance with Chart 12-1, above all in presence of cyclical thermal gradients	1 month	3 months	6 months
3	Check that the impeller is free from defects due to wear and corrosion. See paragraphs 6.2.2 and 6.2.3	1 month	3 months	6 months
4	Check that impeller is clean	1 month	6 months	12 months
5	Check for absence of dangerous vibrations. See also paragraph 3.8.4	1 month	6 months	12 months
6	Check for absence of abnormal noise	1 month	6 months	12 months
7	Check for correct lubrication of motor bearings. See paragraph 8.1	1 month	6 months	12 months
8	Check electrical operating parameters of motor and servomotors installed	1 month	6 months	12 months
9	Check perfect condition of all accessories installed	1 month	6 months	12 months
Additional maintenance for fans with belt-drive transmission				
10	Check tension and wear of drive belts. See paragraph 8.4	1 month	3 months	6 months
11	Check condition of lubrication of bearings in accordance with paragraph 8.1	See also transmission information card		
12	Check temperature of supports containing bearings. After an initial increase due to running in, temperature values should remain constant over time.	1 month	3 months	6 months
Additional maintenance for fans with flexible coupling transmission				
13	Check alignment and lubrication of coupling. See paragraph 8.5	1 month	6 months	12 months

12.4 Energy efficiency measurement system

The energy efficiency of the fan in accordance with Directive 2009/125/EU – Regulation (EU) 327/2011 must be calculated by carrying out a performance trial on the machine in conformity with the ISO 5801 standard.

The measurement must be made with an intake chamber following the layout below (type e installation – measurement with multi-nozzle chamber pursuant to point 30 of the UNI EN ISO 5801 standard):

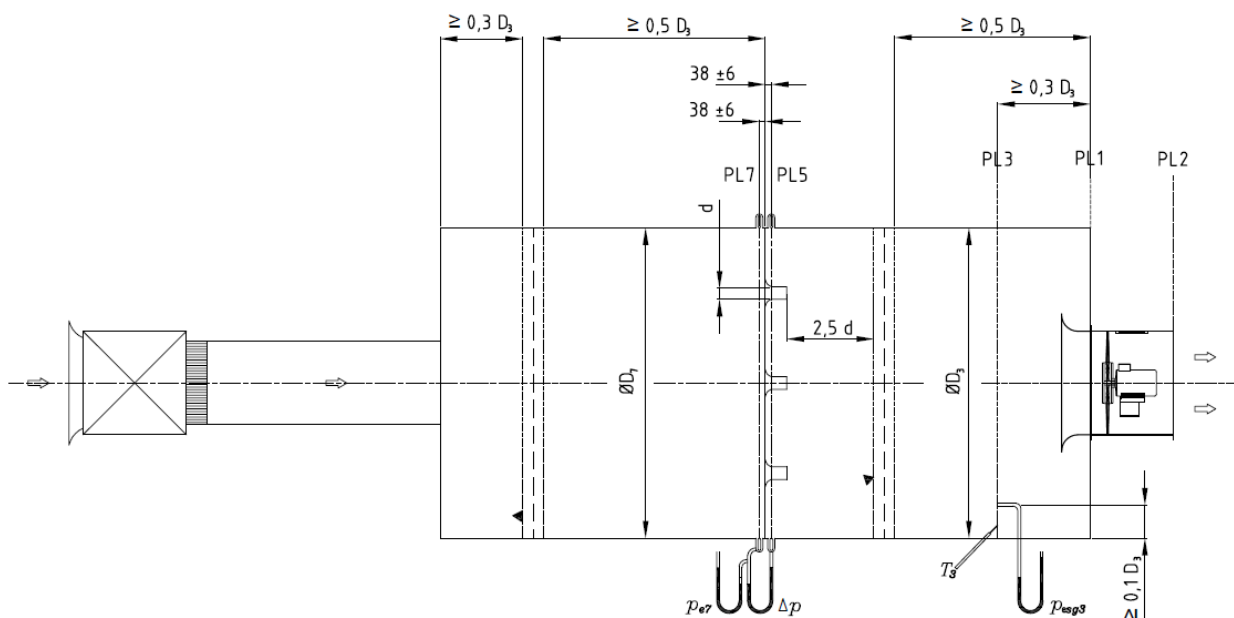



13 INDEX

- abrasion; 62
- accessories; 13; 17; 28; 35; 111; 118
- acoustics; 7; 10; 34; 37; 38; 39; 40
- air; 10; 14; 17; 29; 30; 35; 58; 65; 66
 - clean; 58
- alignment; 53; 54; 55; 74; 96; 97; 98; 99; 117; 118
- angle; 5; 65; 72; 87; 92
 - blade; 5; 65; 87; 92
- assembly; 3; 6; 7; 18; 21; 22; 23; 24; 25; 26; 27; 48; 51; 52; 53; 54; 55; 59; 71; 72; 76; 80; 82; 83; 99; 106; 111
- ATEX; 14; 27; 28
- balance; 80; 82; 87; 88; 92
- base; 3; 10; 13; 14; 16; 17; 18; 19; 21; 22; 28; 42; 48; 51; 52; 53; 54; 68; 80; 83; 87; 90; 99; 111; 118
- bearings; 4; 5; 6; 7; 13; 15; 31; 33; 47; 55; 60; 61; 66; 68; 69; 70; 71; 72; 78; 79; 100; 101; 102; 103; 104; 105; 107; 108; 109; 111; 117; 118
- belts; 4; 5; 7; 13; 15; 29; 32; 53; 55; 61; 66; 67; 73; 74; 93; 97; 98; 99; 111; 118
 - tension; 7; 53; 73; 74
- blades; 7; 10; 33; 62; 65; 87; 92; 93; 112; 116
- bushes; 53; 55; 81; 82; 84; 86; 93; 94; 95; 97; 111
- casing; 4; 6; 13; 14; 29; 30; 42; 46; 47; 51; 52; 53; 54; 57; 60; 62; 83; 90; 111
- chains; 41; 42; 46
- characteristics; 10; 14; 28; 30; 32; 34; 48; 56; 68; 74; 87; 92
- checks; 4; 13; 15; 28; 30; 31; 47; 48; 55; 56; 60; 61; 62; 64; 76; 82; 87; 92; 117
- classification; 30
- cleaning; 4; 30; 55; 62; 73; 74; 76; 77; 94; 111
- components; 6; 7; 13; 15; 29; 30; 31; 33; 51; 52; 53; 54; 109; 111; 112
- connection; 3; 4; 6; 13; 16; 18; 21; 22; 27; 29; 32; 42; 49; 56; 57; 58; 59; 76; 117
- connector; 56
 - grounding; 56
- control; 13; 31; 56; 80
- cooling fan; 13; 101; 113; 114
- corrosion; 62; 63; 118
- coupling; 4; 7; 32; 66; 74; 75
- couplings; 6; 7; 10; 13; 27; 32; 45; 48; 54; 55; 59; 67; 75; 76; 100; 111; 117; 118
 - anti-vibration; 27; 48; 111
 - flexible; 10; 13; 45; 54; 67; 118
 - flexible; 6; 7; 55; 59; 75; 76; 117
- covers; 102; 104; 106; 110
- cycle; 15; 30; 31; 33; 63; 111
 - life cycle; 15; 31; 33; 111
- diameter; 51; 52; 73; 81; 88
- directives; 14; 27; 28; 56; 67; 119
- dismantling; 5; 80; 83; 93; 98; 101; 111; 112; 113; 114
- ducts; 4; 6; 14; 16; 17; 18; 21; 22; 27; 30; 35; 49; 59; 65; 76
- duration; 15; 68
- dust; 14; 27; 30; 47; 62; 77
- efficiency; 5; 17; 28; 117; 119
 - energy; 5; 119
- emissions; 3; 34
 - acoustics; 3; 34
- energy; 10; 13; 14; 60; 61
- environment; 3; 28; 29; 30; 34; 35; 62; 80; 100; 105; 111; 117
- equipment; 41; 48; 49; 67; 80; 91; 111
- exit; 10; 16; 18; 19; 21; 22; 27; 29; 35; 38; 40; 49; 59; 76
- explosion; 14; 28
- fan; 1; 3; 4; 5; 6; 7; 8; 9; 10; 11; 12; 13; 14; 15; 16; 17; 18; 19; 21; 22; 23; 27; 28; 29; 30; 31; 32; 33; 34; 35; 41; 42; 43; 44; 45; 46; 47; 48; 49; 51; 52; 53; 54; 55; 56; 57; 58; 59; 60; 61; 62; 63; 65; 67; 68; 69; 70; 74; 76; 77; 79; 80; 87; 88; 92; 99; 100; 111; 112; 113; 114; 116; 117; 118; 119
- filters; 76
- fixing; 3; 7; 18; 21; 22; 23; 28; 29; 31; 48; 49; 51; 52; 53; 54; 55; 62; 82; 83; 84; 86; 87; 90; 91; 92; 93; 94; 99; 102; 116
- flange; 111; 112
- flow capacity; 41; 46; 65
- flow; 3; 6; 10; 11; 14; 16; 18; 49; 65; 117
- fluid; 4; 9; 10; 13; 14; 27; 28; 29; 34; 49; 58; 59; 62; 65; 67; 76; 77; 111
 - hot; 9; 29; 67
- friction; 97
- gaskets; 59
- grease; 7; 60; 68; 69; 70; 105; 109; 111
- grounding; 56
- guards; 3; 4; 7; 9; 13; 15; 16; 17; 18; 19; 21; 22; 23; 27; 28; 29; 30; 51; 52; 53; 54; 60; 61; 62; 111; 118
- holes; 29; 42; 44; 45; 55; 57; 80; 81; 82; 83; 84; 88; 89; 90; 93; 94; 95; 97
- hub; 5; 7; 19; 33; 37; 38; 39; 40; 80; 81; 82; 84; 87; 88; 89; 91; 112; 116

identification plate; 1; 6; 10; 12; 14; 28; 49; 56; 59; 60; 61; 65; 69; 77; 117
 imbalance; 66
 impeller; 4; 5; 10; 11; 13; 14; 15; 19; 29; 30; 32; 33; 35; 44; 45; 47; 51; 52; 57; 60; 61; 62; 66; 67; 77; 78; 80; 81; 82; 83; 84; 85; 86; 87; 88; 89; 90; 91; 92; 100; 101; 102; 103; 107; 108; 111; 117; 118
 inspection; 9; 30; 62; 66; 67
 installation; 3; 7; 8; 14; 16; 17; 18; 19; 21; 22; 27; 28; 29; 30; 32; 34; 35; 48; 49; 53; 54; 56; 61; 65; 75; 76; 111; 112; 117; 119
 intake; 6; 14; 16; 17; 18; 19; 21; 22; 27; 29; 35; 38; 40; 49; 50; 59; 65; 76; 111; 119
 interference; 80; 111
 inverter; 31; 32; 66
 lifting lugs; 45
 lifting; 3; 6; 9; 28; 41; 42; 43; 44; 45; 46; 47; 67; 91
 load; 7; 41; 42; 46; 48; 73; 76
 lubricants; 68; 70; 74
 lubrication; 9; 30; 60; 67; 68; 69; 74; 75; 117; 118
 interval; 68; 69
 maintenance; 3; 15; 17; 30; 33; 49; 56; 67; 68; 70; 74; 76; 80
 materials; 14; 33; 62; 63; 66; 76; 77; 111
 meshes; 6; 7; 17; 19; 20; 21; 23; 24; 25; 26; 56; 61
 misalignment; 48; 96
 motor pedestal; 54; 55; 99; 111
 motor; 3; 10; 11; 13; 14; 17; 29; 32; 33; 35; 42; 44; 45; 51; 52; 53; 54; 56; 57; 58; 60; 61; 65; 66; 67; 69; 80; 81; 82; 83; 84; 88; 89; 90; 93; 95; 96; 98; 99; 111; 117; 118
 electric; 10; 14; 32; 56; 111
 movement; 3; 9; 28; 41; 46; 67; 80; 88
 multi-stage; 67
 noise/noisiness; 3; 10; 31; 34; 35; 61; 97; 118
 nuts and bolts; 3; 5; 17; 18; 21; 22; 23; 31; 48; 49; 51; 52; 53; 54; 60; 61; 62; 92; 99; 111; 115; 116; 117; 118
 nuts; 51; 52; 89; 92
 oil; 29
 operation; 10; 13; 15; 28; 29; 30; 31; 32; 33; 34; 35; 41; 48; 49; 60; 61; 62; 65; 66; 68; 74; 75; 77; 99; 118
 paint/paintwork; 14; 62; 64
 parts; 9; 13; 17; 28; 29; 31; 32; 33; 49; 51; 52; 53; 54; 62; 65; 80; 85; 88
 lifting equipment; 80; 85; 88
 personal protective equipment (PPE); 28; 34; 41; 42; 48; 49; 54; 76; 108;
 play; 6; 7; 51; 52; 71; 72; 74; 83; 95
 positions; 3; 11; 17; 33; 34; 42; 46; 48; 51; 53; 54; 65; 88; 96; 103; 108
 power supply; 30; 32; 56; 66; 67; 117
 voltage; 56; 65
 power; 10; 32; 34; 35; 56; 65; 87; 92; 97
 acoustic; 10; 35
 absorbed; 10; 97
 installed; 87; 92
 nominal; 10
 pressure; 4; 10; 14; 34; 35; 65; 76
 acoustic; 10; 34; 35
 atmospheric; 14
 dynamic; 10
 resistance; 65
 static; 10
 pre-tension; 74
 pulleys; 5; 13; 29; 32; 53; 55; 67; 70; 73; 93; 94; 95; 96; 97; 98; 99; 100; 104; 111
 qualified personnel; 41; 48; 49; 56; 67; 80; 111
 range; 10; 17; 33; 58
 reassembly; 76; 80
 recess; 89; 94; 103; 104; 108
 reliability; 15; 67
 removal; 9; 17; 28; 29
 ring; 61; 70; 87; 102; 103; 104; 105; 106; 107; 108; 109; 110
 spring locking ring; 103; 104; 107; 108
 external ring; 61; 70; 104; 109
 internal ring; 103; 105; 107; 108
 spring locking ring; 103
 risks; 3; 8; 14; 16; 17; 28; 29; 30; 31; 34; 35; 42; 46; 62; 117
 rotation direction; 33; 46
 rotation; 10; 13; 14; 15; 30; 31; 32; 33; 35; 56; 60; 61; 65; 66; 70
 direction; 56; 60; 65; 117
 safety; 3; 8; 9; 15; 16; 17; 28; 30; 32; 46; 56; 60; 61; 62; 67; 68; 111; 117
 screws; 7; 28; 29; 55; 82; 83; 84; 86; 87; 90; 91; 92; 95; 96; 97; 99; 102; 104; 115; 116
 seals; 14; 27; 29; 102; 106; 110
 sensors; 61
 serial number; 18; 21; 22; 77
 series; 4; 7; 16; 37; 38; 39; 40; 57; 74; 79; 112
 shaft; 5; 13; 29; 32; 44; 51; 52; 55; 68; 78; 80; 81; 82; 83; 88; 89; 90; 92; 93; 94; 95; 100; 101; 102; 103; 105; 106; 107; 108; 109; 110
 slipping; 74



speed; 3; 6; 10; 15; 29; 31; 32; 33; 35; 38; 40; 46; 57;
61; 65; 66

nominal; 33

spline; 88; 94; 95

standards; 30; 34; 56; 119

steel; 5; 7; 10; 19; 33; 38; 40; 80; 87; 111; 116

stainless steel; 33

supports; 5; 7; 13; 48; 52; 55; 60; 61; 68; 69; 100; 101;
102; 103; 104; 105; 106; 107; 108; 110; 111; 117; 118

one-piece; 5; 52; 100; 105

surfaces; 10; 29; 35; 46; 64; 67; 81; 94

symbols; 9; 28; 42; 44; 45; 118

system; 14; 16; 17; 27; 29; 56; 60; 65; 76

temperature; 13; 27; 29; 31; 33; 61; 67; 70; 74; 105;
107; 118

high; 17; 27; 30

thickness; 64

tightening torques; 115

tightening; 5; 7; 17; 48; 49; 55; 60; 61; 72; 97; 115; 116;
117; 118

tools; 17; 81; 86; 95; 98

transmission; 4; 5; 7; 10; 13; 15; 27; 29; 32; 33; 35; 52;
53; 54; 55; 60; 61; 67; 68; 69; 73; 74; 78; 79; 93; 95;
97; 99; 100; 101; 102; 103; 104; 105; 106; 107; 108;
109; 111; 113; 114; 117; 118

transport; 41; 55; 62; 67; 77

use; 3; 10; 14; 15; 17; 23; 28; 29; 32; 33; 42; 48; 49; 56;
61; 67; 74; 77; 80; 82; 87; 88; 92; 116; 118

conditions of; 32

improper; 3; 28

intended; 14

intense; 118

version; 3; 4; 5; 6; 7; 11; 13; 19; 42; 43; 44; 45; 48; 51;
52; 53; 54; 55; 68; 78; 99; 112; 113; 114

vibrations; 3; 10; 14; 17; 27; 29; 30; 31; 33; 34; 48; 51;
52; 61; 62; 77; 87; 92; 97; 118

washer; 51; 52; 82; 83; 84; 86; 89; 90

spring; 83; 90

wear; 15; 17; 30; 62; 74; 77; 97; 118

welds; 49; 61; 62