



Centrifugal fans
Warnings and instructions for use
Translation from the original language



Excerpt from the Declaration of Conformity



Ferrari Ventilatori Industriali S.p.A
36071 Arzignano (Vicenza)
Via Marchetti, 28
Tel. +39 0444 471100
Fax +39 0444 471105
<http://www.ferrariventilatori.it>

DECLARATION OF CONFORMITY

Pursuant to Annex IIA of Machinery Directive 2006/42/EC

The Manufacturer: Ferrari Ventilatori Industriali S.p.A.
Via Marchetti, 28
36071 Arzignano (VI) – Italy

DECLARES

under its own responsibility that the machine denominated “industrial fan”:



Main Index

1	INTRODUCTION	9
1.1	Purpose of this manual	9
1.2	Safety symbols used in this manual	9
1.3	Safety symbols used on fans	10
2	GENERAL INFORMATION	11
2.1	Definitions, basic principles, terminology used and correlated documents	11
2.2	Construction details of centrifugal fans	12
2.2.1	Versions, motor positions and working temperatures	12
2.2.2	Fan orientations	13
2.2.3	Standard motor positions for different fan orientations	14
2.3	Fan identification	15
2.4	Description of fan	16
2.5	Envisaged use and foreseeable uses according to experience, and prohibited uses	17
2.6	Life cycle of fan	18
3	WARNINGS AND MAIN SAFETY INDICATIONS	19
3.1	Installation instructions: general information	19
3.2	Installation type A: Instructions for assembly, installation and connections	21
3.3	Installation type B: Instructions for assembly, installation and connections	22
3.4	Installation type C: Instructions for assembly, installation and connections	23
3.5	Assembly and fastener diagrams for fixing guards RC, RQ and BP	24
3.6	Installation type D: Instructions for assembly, installation and connections	29
3.7	Risks involved in foreseeable incorrect handling and/or abnormal uses based on experience	30
3.8	Other risks related to fans pursuant to UNI EN ISO 12499	31
3.8.1	Specific risks with fans during installation	31
3.8.2	Specific risks with fans during maintenance	31
3.8.3	Environmental risks	32
3.8.4	Vibration risks	32
3.8.5	Operating speed risks	33
3.8.6	Noise emission risks	36
3.8.7	General information on noise emission data	37
4	TRANSPORT, MOVEMENT AND STORAGE	43
4.1	Lifting and movement	43
4.2	General warnings for lifting separate fan parts	43
4.3	Fan lifting instructions	44
4.3.1	Lifting version 1-9-12 centrifugal fans	44



4.3.2	Lifting version 4 centrifugal fans	45
4.3.3	Lifting centrifugal fans with double intake	47
4.3.4	Lifting version 8 centrifugal fans	48
4.3.5	Lifting fans packed in crate	49
4.4	Storage	50
5	INSTALLATION	51
5.1	General information	51
5.1.1	Minimum installation distances	52
5.2	Installation of centrifugal fans	53
5.2.1	Centrifugal fans with single intake	53
5.2.2	Centrifugal fans with double intake	57
5.3	Installing and adjusting drive belts and final checks	58
5.4	Electrical connections	59
5.5	Connection to ducts	60
6	CHECKS TO BE MADE BEFORE AND AFTER STARTING	62
6.1	Preliminary checks and first starting of the machine	62
6.2	Checks to be made with fan fully operating	62
6.2.1	Visual checks on guards	63
6.2.2	Checking and cleaning parts in contact with fluids	64
6.2.3	Visual inspections on blades and casing	64
6.2.4	Dimensional checks	65
7	CENTRIFUGAL FAN OPERATING MALFUNCTIONS	66
7.1	Most frequent malfunctions	66
8	MAINTENANCE	68
8.1	Bearing lubrication	69
8.2	Checking spherical roller bearings	72
8.3	Checking self-aligning ball bearings	73
8.4	Adjusting drive belt tension and cleaning belts	74
8.5	Flexible couplings	75
8.6	Filters and pressure gauges	77
8.7	Flexible anti-vibration joints between the fan and ducting	77
8.8	Checking and cleaning parts in contact with fluids	78
9	TECHNICAL CHARTS	79
9.1	ST supports versions A – AL – B - BL	79
9.2	SN supports versions A – AL - B - BL	80
9.3	Standard supports and bearings installed on fans with transmission	81

10	DISMANTLING AND REASSEMBLING ESSENTIAL COMPONENTS	84
10.1	Replacement of intake on centrifugal fans	84
10.1.1	Dismantling intake	84
10.1.2	Reassembling intake	86
10.2	Casing	88
10.3	Replacement of impeller	89
10.3.1	Dismantling impeller	90
10.3.2	Reassembling impeller	94
10.4	Replacing drive belts	97
10.4.1	Assembling and dismantling pulleys	97
10.4.2	Assembling and dismantling drive belts	101
10.5	Replacing shaft and bearings on one-piece support	103
10.5.1	Dismantling shaft on one-piece support	103
10.5.2	Reassembling shaft on one-piece support	108
10.6	Replacement of bearings and flexible coupling on version 8 fans	113
10.7	Replacement of stuffing box seal	116
10.7.1	Dismantling stuffing box seal	116
10.7.2	Reassembling stuffing box seal	118
11	FINAL DISMANTLING AND DISPOSAL OF FANS	120
11.1	Centrifugal fans with single intake versions 1-9-12	121
11.2	Centrifugal fans with double intake versions 6 -18	121
11.3	Version 8 centrifugal fans	122
12	TECHNICAL APPENDICES	123
12.1	Tightening torques for nuts and bolts	123
12.2	Checklist before starting fans	124
12.3	Programmed maintenance intervals	125
12.4	Energy efficiency measurement system	126
13	INDEX	127



Index of Diagrams

Fig. 2-1 Centrifugal fan versions	12
Fig. 2-2 Centrifugal fan versions with double intakes	13
Fig. 2-3 Fan orientations	13
Fig. 2-4 Standard motor positions for different fan orientations	14
Fig. 2-5 Identification plate of fan described by this manual	15
Fig. 2-6 Key to reading fan identification plate	15
Fig. 2-7 Example of version 12 with fan components indicated	16
Fig. 3-1 BP mesh guard	21
Fig. 3-2 RC mesh guard	22
Fig. 3-3 RQ mesh guard	22
Fig. 3-4 Assembly diagram for RC or RQ mesh guards on intake studs	24
Fig. 3-5 Assembly diagram for RC or RQ mesh guards on threaded holes in casing	26
Fig. 3-6 Assembly diagram for BP guard	27
Fig. 3-7 Positions of measurement microphones	38
Fig. 4-1 Example of lifting version 1 centrifugal fans	44
Fig. 4-2 Example of lifting version 9 centrifugal fans	45
Fig. 4-3 Example of lifting version 12 centrifugal fans	45
Fig. 4-4 Example of lifting version 4 centrifugal fans	46
Fig. 4-5 Example of lifting centrifugal fans with double intake	47
Fig. 4-6 Example of lifting for fans with double intakes with a flexible coupling	48
Fig. 4-7 Example of lifting version 8 centrifugal fans	48
Fig. 4-8 Example of lifting fans packed in crate	50
Fig. 5-1 Examples of fan fixing points	51
Fig. 5-2 Minimum installation distances with intake duct	52
Fig. 5-3 Minimum installation distances with free intake	53
Fig. 5-4 Assembly of version 12 fans	56
Fig. 5-5 Assembly of version 8 fans	56
Fig. 5-6 Assembly of centrifugal fans with double intake	57
Fig. 5-7 Diagram of electrical connections for one-speed and two-speed motors	60
Fig. 5-8 Assembly tolerances for flexible joints	60
Fig. 5-9 Minimum installation distances with intake duct	61
Fig. 8-1 Checking radial clearance on bearings	72
Fig. 8-2 Axial movements	73
Fig. 8-3 Checking drive belt tension	74
Fig. 8-4 Setting drive belt tension	74
Fig. 8-5 Axial play	75
Fig. 8-6 Angular misalignment	75
Fig. 8-7 Parallel misalignment	75
Fig. 9-1 ST supports versions A – AL – B - BL	79

Fig. 9-2 SN supports versions A – AL – B - BL	80
Fig. 10-1 Centring of impeller intake on high-pressure series – VCM	87
Fig. 10-2 Centring of impeller intake on series MEC – ART	87
Fig. 10-3 Centring of impeller intake on series FQ-FR-DFR-FS-DFS	87
Fig. 10-4 Hub with circumferential extraction groove	89
Fig. 10-5 Hub with threaded extraction holes	89
Fig. 10-6 Securing impeller lifting tube	92
Fig. 10-7 Pulley holes	97
Fig. 10-8 Angular misalignment	99
Fig. 10-9 Parallel misalignment	99
Fig. 10-10 ST...A... one-piece support with radial ball bearings both on impeller side and transmissionside	103
Fig. 10-11 ST...B... one-piece support with radial ball bearings on impeller side and roller bearings on transmission side	104
Fig. 10-12 Support with cooling fan	104
Fig. 10-13 Components of version 8 fans driven by flexible coupling	113
Fig. 10-14 Flexible coupling	114
Fig. 10-15 Detail of seal	116
Fig. 10-16 Sealing ring slits	118
Fig. 11-1 Exploded view of version 12 fan	121
Fig. 11-2 Exploded view of centrifugal fan with double intake	121
Fig. 11-3 Exploded view of version 8 fan	122



Index of Charts

Chart 3-1 Dimensions and number of fixing nuts for RC and RQ mesh guards on studs	25
Chart 3-2 Dimensions and number of fixing bolts for RC and RQ mesh guards for threaded holes in casing	26
Chart 3-3 Dimensions and number of fixing bolts for BP guard	27
Chart 3-4 Acoustic power emitted Lw(A) (dBA)	39
Chart 3-5 Acoustic power emitted Lw(A) (dBA)	40
Chart 3-6 Acoustic pressure emitted Lw(A) (dBA)	41
Chart 3-7 Acoustic pressure emitted Lw(A) (dBA)	42
Chart 5-1 Assembly of version 1-8-9-12 fans	55
Chart 5-2 Assembly of centrifugal fans with double intake	57
Chart 8-1 Quantity of grease for first filling of supports and bearings on fans with transmission	70
Chart 8-2 Relubrication intervals and quantity of grease according to fan rotation speed	71
Chart 8-3 Checking radial clearance on bearings	72
Chart 8-4 Tightening angle, axial movement and minimum residual clearance on ball bearings	73
Chart 8-5 Setting drive belt tension: test load and deflection	74
Chart 8-6 Technical characteristics of flexible couplings	76
Chart 9-1 ST supports versions A – AL – B – BL	79
Chart 9-2 SN supports versions A – AL – B – BL	80
Chart 9-3 Standard supports and bearings installed on fans with transmission	81
Chart 9-4 Standard supports and bearings installed on fans with transmission	82
Chart 9-5 Standard supports and bearings installed on fans with transmission	83
Chart 10-1 Tightening torques	100
Chart 12-1 Tightening torques M for bolts with ISO metric threads	123

1 INTRODUCTION



1.1 Purpose of this manual


This manual contains instructions and warnings, and constitutes documentation that must **compulsorily** accompany the product. Otherwise the product is lacking one of its essential safety requisites.

The manual must be kept with care, and must be made available to all persons involved with the product.


The warnings are intended to safeguard the safety of persons exposed to residual risks.

The instructions provide indications for the most appropriate conduct for the correct use of fans as intended by the manufacturer.

	<p>WARNING:</p> <p><i>The safety precautions used for the fan must also be adapted to its specific destination of use.</i></p>
	<p><i>The safety precautions differ according to the type of fan installation, as specified in paragraph 3.1 below.</i></p> <p><i>The information given in this manual is therefore indispensable for the use of fans in conformity with the destination of use of the product and without risks.</i></p>




	<p><i>In this manual the letters "FVI" stand for "Ferrari Ventilatori Industriali S.p.A."</i></p>
---	---

No part of this manual may be copied, reproduced or transmitted in any form whatsoever and by any electronic, mechanical or photographic means without the express authorization of **FVI**.

	<p><i>The FVI Technical Office is fully at your disposal for all information required.</i></p>
---	--






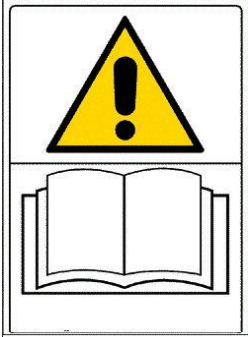
1.2 Safety symbols used in this manual

Certain items of particular interest in this manual may be preceded by one of the following symbols:

	<p>DANGER: <i>Indicates situations that might cause personal injuries.</i></p>
	<p>DANGER: <i>Live electrical components.</i></p>
	<p>WARNING: <i>Indicates important information of particular general interest</i></p>

1.3 Safety symbols used on fans

The following safety symbols are used on **FVI** fans:

	<p>Prohibited to lubricate and/or adjust moving parts.</p>
	<p>Prohibited to remove guards.</p>
	<p>Hazard due to presence of moving parts. This symbol is applied near the inspection hatches provided on fans. It is permitted to open inspection hatches only when all moving parts have reached a complete standstill.</p>
	<p>Indication of a lifting point. This symbol is applied near the points identified by FVI for lifting and moving the fan.</p>
	<p>Hot surfaces >60 °C. Danger of burns or scalding. Hot surfaces – Emission of hot fluids. This symbol is applied if the fan is used to move hot fluids.</p>
	<p>Generic hazard warning. Positioned near the condensation discharge plug (if present), to warn of the possible presence of hazardous substances and/or substances at a high temperature.</p>

2 GENERAL INFORMATION

2.1 Definitions, basic principles, terminology used and correlated documents

- Point 3.1 of the UNI EN ISO 13349 standard defines a fan as “rotary-bladed machine which receives mechanical energy and utilizes it by means of one or more impellers fitted with blades to maintain a continuous flow of air or other gas passing through it and whose work per unit mass does not normally exceed 25 kJ/kg.”
- Point 3.6.1 of the UNI EN ISO 13349 standard defines a radial-flow (or centrifugal) fan as “a fan in which the air enters the impeller with an essentially axial direction and leaves it in a direction perpendicular to this axis.”
- The blades may have the following shapes: negative (the blade moves the fluid with the rear or convex part), positive (the blade moves the fluid with the front or concave part), radial (straight, the blade can move the fluid with the rear or front part indifferently, unless reinforcements are provided on one side of the blade).

The fundamental dimensions that define a fan are as follows:

- Volumetric flow: this is the volume of fluid passing through the fan in a certain period of time — one second (m^3/s), one minute (m^3/min) or one hour (m^3/h);
- Static pressure: this is the energy imparted by the impeller to overcome the resistance offered by the system to the passage of fluid (measured in mm of water column = mm w.c. or Pascal = Pa);
- Dynamic pressure: this is the energy possessed by the fluid as a result of the speed imparted by the impeller at the output opening of the fan (measured in mm w.c. or Pa);
- Total pressure: this is the arithmetical total of static pressure and dynamic pressure (measured in mm w.c. or Pa);
- Rotation speed: this is the rotation speed of the impeller, and is measured in revolutions per minute (RPM);
- Efficiency: this is the percentage ratio between the energy that the fan manages to transmit to the fluid and the energy supplied by the motor to the impeller; it depends on impeller characteristics, and has no measurement units;
- Power absorbed: this is the power needed (provided by the motor) by the fan for correct operation, and is measured in kW;
- Identification plate motor power: this is the nominal power that the motor can provide; it must always be greater than the power absorbed by the fan, and is measured in kW;
- Acoustic pressure level: this is the energy propagated into the channel of the external ear and that generates vibrations of the ear drum, namely the level of noise emitted by the fan; it is measured in decibels using scale A (a scale that allows the impact of noise on the human ear to be assessed, according to the frequency of the noise);
- Acoustic power: this is the index of emission of acoustic power, and constitutes an intrinsic and constant characteristic of a sound source; it is expressed in watts.

The following documents are correlated to this manual:

- SCHAT01 Technical Information Sheet for the fan, which lists dimensions, weights, rotation speeds, fluid types, acoustic pressure and data on flexible couplings and vibration dampeners.
- CART01 Transmission Information Card, which indicates the characteristics of the transmission installed on the fan.
- The instruction and warnings manual of the manufacturer of the electric motor (if supplied together with the fan).

2.2 Construction details of centrifugal fans

2.2.1 Versions, motor positions and working temperatures

<p>Version 1</p> <p>Belt drive. Overhanging impeller fitted on shaft. Supports mounted on motor pedestal outside air flow. Maximum air temperature 60°C without cooling fan, 300 °C with cooling fan.</p>		<p>Version 4</p> <p>Direct drive. Impeller fitted directly to shaft of motor, which is supported by the motor pedestal. Maximum air temperature 60°C without cooling fan; 150 °C with cooling fan.</p>	
<p>Version 5</p> <p>Direct drive. Impeller fitted directly to shaft of motor, which is fixed to the motor pedestal disk. Maximum air temperature 60°C without cooling fan; 150 °C with cooling fan.</p> <p>CAUTION! VERSION 5 FANS ARE NORMALLY INSTALLED WITH A VERTICAL OPERATING AXIS, AS INDICATED IN THE ILLUSTRATION. FOR APPLICATIONS WITH A HORIZONTAL AXIS (FIXING ON OUTPUT OPENING OR INTAKE OPENING), FIRST CONSULT THE FVI TECHNICAL OFFICE.</p>		<p>Version 8</p> <p>Drive with flexible coupling. Overhanging impeller fitted on shaft. Supports and motor mounted on motor pedestal outside air flow. Maximum air temperature 60°C without cooling fan, 300°C with cooling fan.</p>	
<p>Version 9</p> <p>Belt drive. Same as version 1 with motor supported to side of motor pedestal. Maximum air temperature 60°C without cooling fan, 300°C with cooling fan.</p>		<p>Version 12</p> <p>Belt drive. Same as version 1 with fan and motor supported by foundation frame. Maximum air temperature 60°C without cooling fan, 300°C with cooling fan.</p>	
		<p>Plan of motor positions for belt-drive transmissions.</p> <p>(positions X and Y are possible only with special constructions)</p>	

Fig. 2-1 Centrifugal fan versions

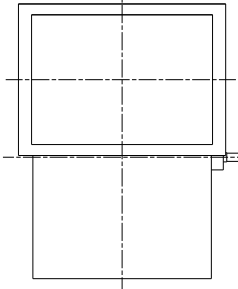
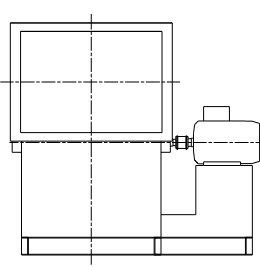
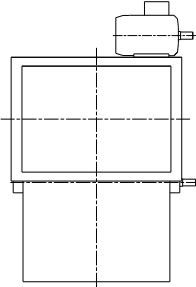
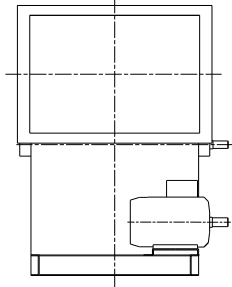
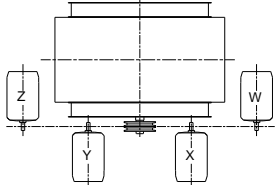
<p>Version 6</p> <p>Belt drive. Impeller fitted between supports, mounted on posts inside the air flow. Maximum air temperature 40°C, with bearings with C3 clearance maximum 60°C.</p>		<p>Version 17</p> <p>Drive with flexible coupling. Impeller fitted between supports, mounted on posts inside the air flow. Motor supported by same pedestal as fan. Maximum air temperature 40°C, with bearings with C3 clearance maximum 60°C.</p>	
<p>Version 19</p> <p>Belt drive. Same as version 6 with motor mounted on base and supported by the casing. Maximum air temperature 40°C, with bearings with C3 clearance maximum 60°C.</p>		<p>Version 18</p> <p>Belt drive. Same as version 6 with fan and motor supported by the foundation frame. Maximum air temperature 40°C, with bearings with C3 clearance maximum 60°C.</p>	
		<p>Plan of motor positions for belt-drive transmissions.</p> <p>(positions X and Y are possible only with special constructions)</p>	

Fig. 2-2 Centrifugal fan versions with double intakes

2.2.2 Fan orientations

Centrifugal fans can be supplied with 16 different orientations (8 in clockwise direction RD and 8 in anticlockwise direction LG).

The rotation direction of a fan is defined for an observer located on the transmission side.

Orientations RD, LG 180 and 225 are possible only with special constructions.


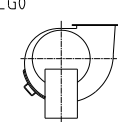
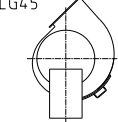
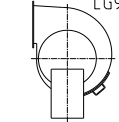
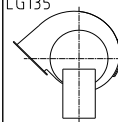
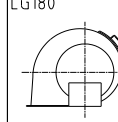
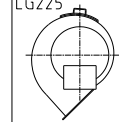
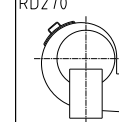
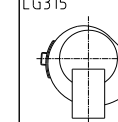

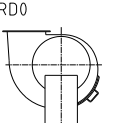
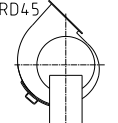
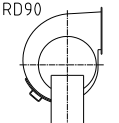
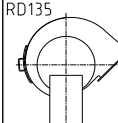
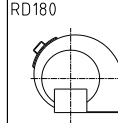
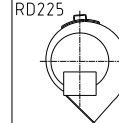
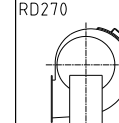
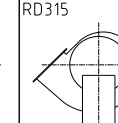
<p>ANTICLOCKWISE ROTATION LG</p> 	<p>LG0</p> 	<p>LG45</p> 	<p>LG90</p> 	<p>LG135</p> 	<p>LG180</p> 	<p>LG225</p> 	<p>RD270</p> 	<p>LG315</p> 
<p>CLOCKWISE ROTATION RD</p> 	<p>RD0</p> 	<p>RD45</p> 	<p>RD90</p> 	<p>RD135</p> 	<p>RD180</p> 	<p>RD225</p> 	<p>RD270</p> 	<p>RD315</p> 

Fig. 2-3 Fan orientations

2.2.3 Standard motor positions for different fan orientations

FVI uses the standard motor positions shown in Fig. 2-4. For reasons of space, series DFR and DFS are exceptions, where the motor is mounted in position W with orientations LG90–LG135, and in position Z with orientations RD90–RD135.

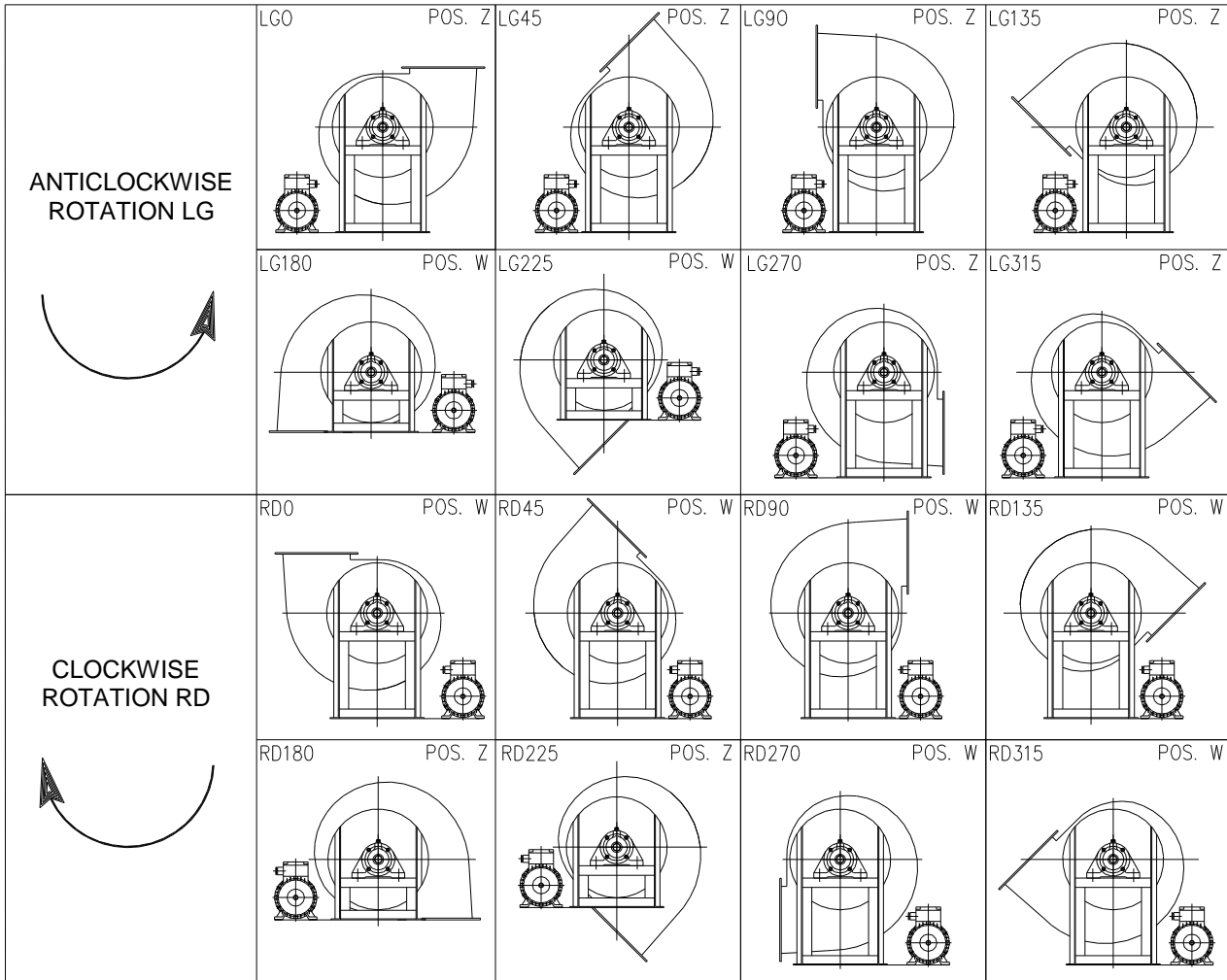


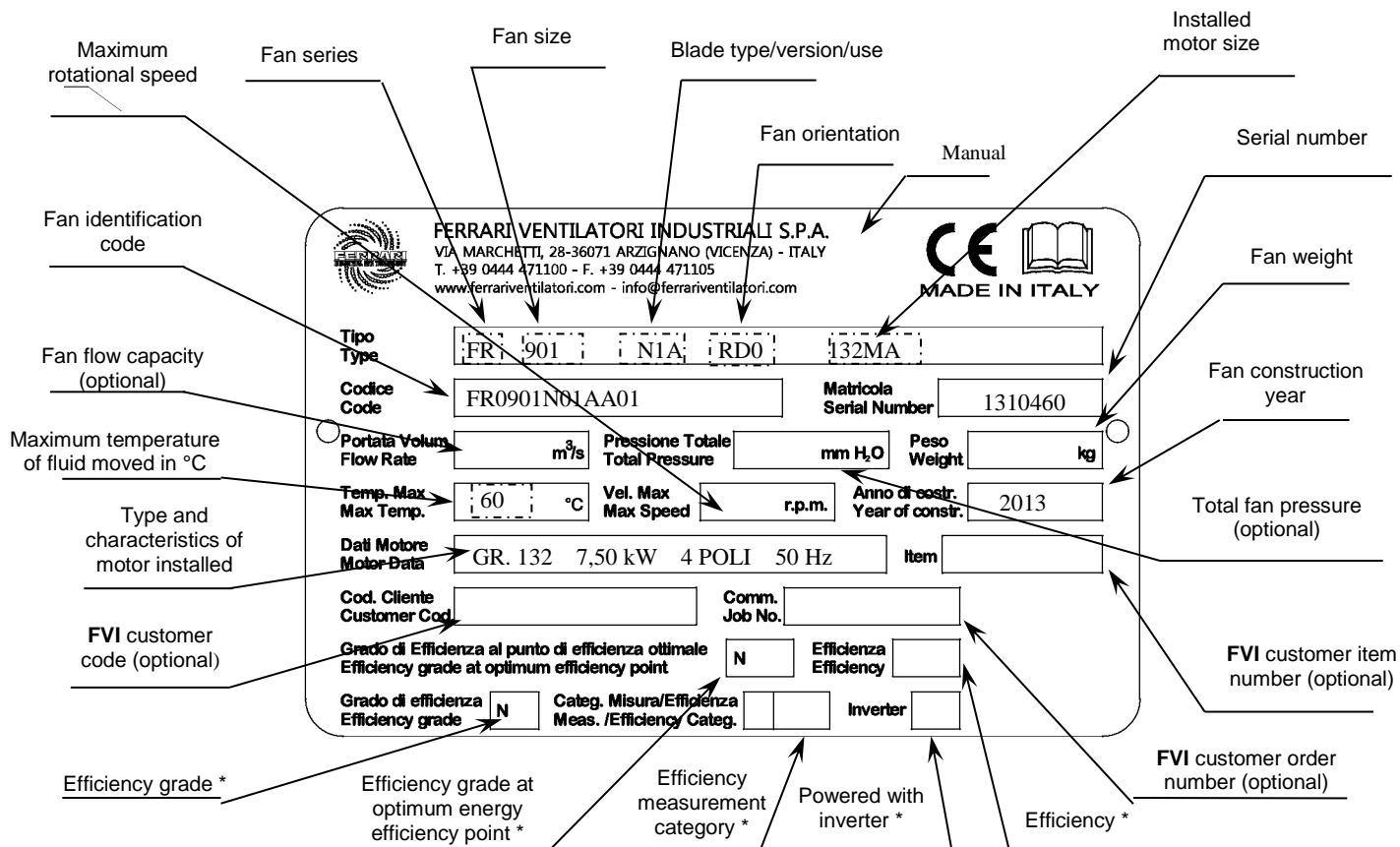
Fig. 2-4 Standard motor positions for different fan orientations

2.3 Fan identification

The identification plate is the only means of fan identification recognized by the manufacturer. It must not be modified, and must not be removed or damaged. Fig. 2-5 shows the plate fitted to the fan.

FERRARI VENTILATORI INDUSTRIALI S.P.A. VIA MARCHETTI, 28-36071 ARZIGNANO (VICENZA) - ITALY T. +39 0444 471100 - F. +39 0444 471105 www.ferrariventilatori.com - info@ferrariventilatori.com		 MADE IN ITALY	
Tipo Type			
Codice Code		Matricola Serial Number	
Portata Volum. Flow Rate	m ³ /s	Pressione Totale Total Pressure	mm H ₂ O
Temp. Max Max Temp.	°C	Vel. Max Max Speed	r.p.m.
Dati Motore Motor Data		Anno di costr. Year of constr.	
Cod. Cliente Customer Cod.	Comm. Job No.		Item
Grado di Efficienza al punto di efficienza ottimale Efficiency grade at optimum efficiency point		N	Efficienza Efficiency
Grado di efficienza Efficiency grade	Categ. Misura/Efficienza Meas. /Efficiency Categ.	Inverter	

Fig. 2-5 Identification plate of fan described by this manual



*In conformity with EU Regulation No. 327/2011

Fig. 2-6 Key to reading fan identification plate

2.4 Description of fan

A centrifugal fan is generally constituted by the following components (identification of components as shown in Fig. 2-7):

- an impeller that rotates to impart the necessary energy to the fluid (2);
- an intake that channels the fluid on the suction side (1);
- a casing housing the impeller, with a spiral shape (5);
- a pedestal to support the motor (4);
- a cooling fan between the impeller and the motor, if the fluids are to be moved with an operating temperature greater than 60°C (24)
- guards to prevent accidental contact with all rotating parts (23-25);

The power that permits rotation of the impeller is provided therefore by a motor (11), usually but not exclusively electrically driven, linked to the impeller directly rather than by other organs of transmission, such as for example:

- transmission by drive belts and trapezoidal pulleys or flexible couplings to transfer the energy provided by the motor (18-19-20-21-22);

For these versions (see also 2.2.1) the following are normally provided:

- a support complete with bearings and transmission shaft for connecting to the impeller and transmission (12);
- a common base to support the fan, the motor and the transmission (10-11);

Fans may be supplied with different construction characteristics that may also include other components not indicated in the above descriptions and that must be defined for each specific case. Fans may also be fitted with additional accessories (as shown on pages 359 to 369 of the “Centrifugal Fan Catalogue”).

FVI fans are always supplied without control and monitoring systems.

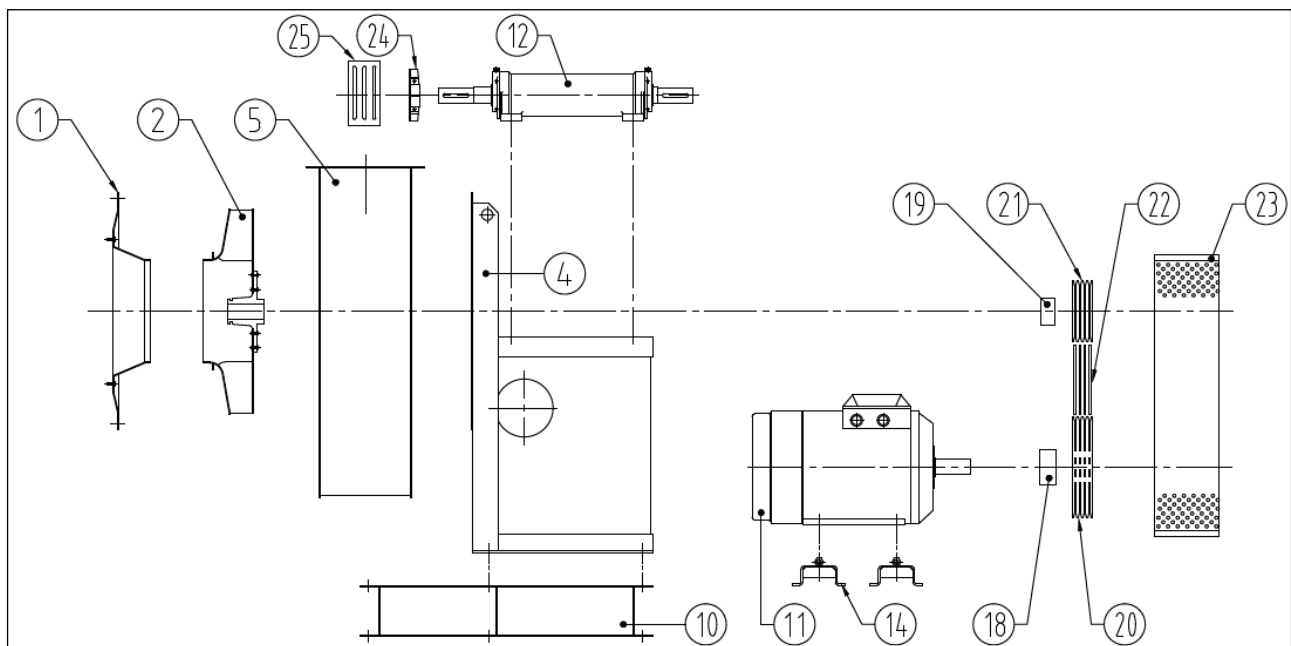


Fig. 2-7 Example of version 12 with fan components indicated

2.5 Envisaged use and foreseeable uses according to experience, and prohibited uses

The envisaged use for the fan with the identification plate as shown in Fig. 2-5 is as follows:

An industrial centrifugal fan is a machine that serves to move a gaseous fluid inside a fluid movement system to which the fan is connected by means of ducts and technical chambers provided for this purpose. The flow of the fluid moved by the machine enters the fan in an axial direction from the intake end, and leaves in a perpendicular direction from the delivery section.

The energy required to move the volumes of fluid entering the system from the suction intake is transferred by the rotation of the impeller inside the casing. Impeller rotation is obtained in most cases by the energy supplied by an electric motor, as indicated earlier in paragraph 2.4 of this manual.

The fan must be used in the flow range specified in the performance diagrams. Use of the fan with flows lower than the minimum value indicated in the diagrams may cause unstable fluid dynamic operation and vibrations.

Centrifugal fans are used in many application associated prevalently with the development of industrial processes. Here is a list of some possible industrial sectors with application examples:

- Cereal milling sector (pneumatic transport in mills) (series MEC, VCM, ART, FQ)
- Food processing sector (drying, cooking, circulation)
- Textile sector (air conditioning and treatment, drying)
- Glass sector (tempering treatments, air supply for burners, circulation)
- Steel sector (air supply for burners and extraction of fumes) (series FA, FC, FE, FG /P; series FS; series K, KA, KB, KC, KM)
- Brick products sector (air supply for burners, circulation, extraction of fumes)
- Woodworking sector (filtration, dust removal) (series FA, FC, FE, FG /P; series FS; series K, KA, KB, KC, KM)
- Tobacco sector (product conditioning and filtration, extraction of fumes) (series FA, FC, FE, FG /P; series FS; series K, KA, KB, KC, KM)
- Paper sector (filtration, dust removal) (series FA, FC, FE, FG /P; series FS; series K, KA, KB, KC, KM)
- Painting sector (filtration, dust removal) (series FA, FC, FE, FG /P; series FR, FS; series K, KA, KB, KC, KM)
- Transport sector such as maritime and railways (conditioning, motor cooling)
- Energy sector (turbine cooling, oil platform conditioning)
- Other applications not listed but agreed with our Engineering and/or Research % Development Area.

Some categories of use other than those described above are excluded, and more specifically:

- Operation of the fan with non-gaseous fluids or with fluids with characteristics different from those defined in the technical information sheet accompanying the fan, since structural damage may be caused to the fan with the possible risk of injury to persons and/or damage to things;
- Operation of the fan in all types of system with pressures (present or even partially generated by the fan) greater than 1.2 times standard atmospheric pressure, since structural damage may be caused to the fan with the possible risk of injury to persons and/or damage to things;
- Operation of the fan in all types of system classified in accordance with the ATEX 2014/34/EC Directive and that move potentially explosive fluids, since risks of ignition/explosion may arise with possible injury to persons and/or damage to things. Fans that are specifically constructed, classified and marked for ATEX conformity for a suitable category for the installation location are excluded, and these must be accompanied by the legally required documentation;
- Operation of the fan in industrial chemical plants where the fluid moved is highly corrosive for the materials used in fan construction, or in the presence of highly toxic fluids where the construction methods of casings and the types of seal used are not suitable for this specific application, since structural damage may be caused to the fan with the possible risk of injury to persons and/or damage to things;



- Operation of the fan in mining industry plants and with underground installations, since additional risks not considered in the use of the fan above ground may arise, with possible injury to persons and/or damage to things.

2.6 Life cycle of fan

The reliability of all components is guaranteed by a production process with ISO 9001 certification and by compliance with the programmed maintenance intervals indicated in paragraph 12.3 of this manual.

The components normally subject to wear are the following:

- bearings, calculated for a theoretical duration normally of 40,000 hours
- drive belts, calculated for a theoretical duration of 25,000 hours

For safety reasons, guards in electrowelded wire must be replaced every 2–3 years.

In the hypothesis of use of the fan at constant speed for two work shifts every day equivalent to 16 hours, calculated for 250 days per year, the expected life cycle for the impeller is equivalent to 40,000 hours.


In case of use in conditions of particularly difficult operation (medium, high), this limit must be reduced. Any such reduction must be assessed in collaboration with the **FVI** Technical Office.

In the specific case of operation at variable speeds, the impeller life cycle must be assessed on a case-by-case basis, and must also be agreed with the **FVI** Technical Office.

Even if it has never operated, an impeller that has been stored for more than ten years must be checked by **FVI** for possible defects before it can be used.

3 WARNINGS AND MAIN SAFETY INDICATIONS

3.1 Installation instructions: general information

	<p>Fans can be installed in four different ways, in conformity with the UNI EN ISO 13349 standard:</p> <ul style="list-style-type: none"> • Type A: open intake and open exit; • Type B: open intake and exit connected to duct; • Type C: intake connected to duct and open exit; • Type D: intake and exit connected to ducts.
---	---


Generally, FVI does not and cannot know which of the above installation types will be chosen and applied by the user, and unless otherwise specified by contract, the fan is supplied for installation type D. The person responsible for designing the system, together with the final user, must conduct an analysis of risks for the specific installation type chosen.


Depending on the way that it is intended to install and insert the fan in the fluid movement system, the following guards must be installed, according to installation type:

- Type A installation: fixed **FVI** guards installed on intake and exit;
- Type B installation: fixed **FVI** guard installed only on intake;
- Type C installation: fixed **FVI** guard installed only on exit;
- Type D installation: no fixed guards installed on intake and exit.

The system designer and the user must ensure that ducting systems are fitted with conformant guards for the duct connections made, as follows:


- Type A installation: no guards (no ducts are connected);
- Type B installation: fixed guard fitted on exit duct;
- Type C installation: fixed guard fitted on intake duct;
- Type D installation: fixed guards fitted both on intake and exit ducts.


	<p>CAUTION:</p> <p><i>Unless otherwise specified by contract, fans are supplied for installation type D in conformity with the UNI EN ISO 13349 standard.</i></p> <p><i>Always verify all safety aspects of the installation type chosen.</i></p>
---	--


	<p>CAUTION:</p> <p><i>Unless otherwise specified by contract, the fan and guards are suitable for installation as a single unit, and must not be subjected to effects of fluid dynamics caused by other machines installed in the same fluid movement system.</i></p>
---	--

With regard to guards to be fitted to ducts, in compliance with the design project, they must prevent access to parts of the fan and its accessories that could cause injuries. They must also be sufficiently robustly constructed to resist the stresses generated by the machine and environmental conditions.


FVI invites users and/or system designers to design, construct and install guards in conformity with the criteria of the UNI EN ISO 12499 standard.

	<p>CAUTION:</p> <p><i>Even with guards installed (regardless of the conditions of supply or installation), the fan may be dangerous due to the effects of indrawn or moved air.</i></p> <p><i>Depending on the dimensions of the fan, this type of danger may even CAUSE DEATH.</i></p> <p><i>The risk of being crushed against the intake grille may be fatal or may cause serious injuries (crushing of body parts, unconsciousness).</i></p>
---	---

	<p>CAUTION:</p> <p><i>It is advisable to adopt precautions that prevent access to the room containing the fan while it is operating, or to keep persons away with fixed guards that maintain a safe distance from the intake opening.</i></p> <p><i>For details consult the UNI EN ISO 13349 and UNI EN ISO 12499 standards.</i></p>
---	---

	<p>WARNING:</p> <p><i>Check the efficiency of all guards every month. In case of wear, damage or breakage, replace them immediately.</i></p>
---	---


Guards must be fixed securely in position using fixings that are not slackened by vibrations, and that require the use of a tool for their removal.

	<p>CAUTION:</p> <p><i>On starting and in compliance with programmed maintenance intervals, check that nuts and bolts are correctly tightened. Monitor vibration levels with a vibrometer, and establish an alarm threshold (see paragraph 12.3).</i></p>
---	---

It is always the responsibility of the installer to guarantee that there is an adequate level of protection against the risk of accidental contact with moving parts.

The installer and the user must also take other types of risk into consideration, and in particular those deriving from the entry of foreign bodies and the intake of explosive, inflammable or toxic gases or gases at a high temperature.


The risks involved in maintenance operations must also be taken into consideration. It must be possible to perform these operations in conditions of maximum safety, by isolating the fan from the motor or by taking other suitable precautions.

	<p>CAUTION:</p> <p><i>A safety procedure for access to the fan must be compiled, taking into consideration the indications provided by the manufacturer, information deriving from the analysis of risks at the installation point and safety requirements in workplaces.</i></p>
---	--

3.2 Installation type A: Instructions for assembly, installation and connections

In case of type A installations, since neither the intake nor exit of the fan are connected to ducts, guards must be fitted on both the intake and the exit.

Guard dimensions can be obtained from the dimensional drawings given in catalogues, from scale and non-scale drawing programs downloadable from the reserved area of the website, or from any dimensional drawings provided as documentation together with the products supplied.

	<p>CAUTION:</p> <p><i>Guards are designed to protect against accidental contacts and to resist the pressures generated only by the fan to which they are fitted.</i></p> <p><i>Each guard, if supplied individually, can be used only on the fan for which it was designed. If therefore a guard is ordered individually, it is compulsory to provide the reference details of the fan to which it will be fitted (serial number).</i></p>
---	---

A BP guard must be bolted to the fan exit, composed of a mesh with square apertures welded to a flange with the same dimensions as the exit flange of the fan (see Fig. 3-1).

The type and number of bolts necessary are shown in Chart 3-3, and tightening torques are shown in Chart 12-1.

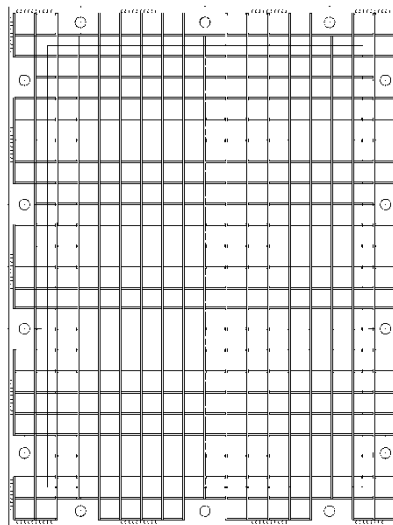
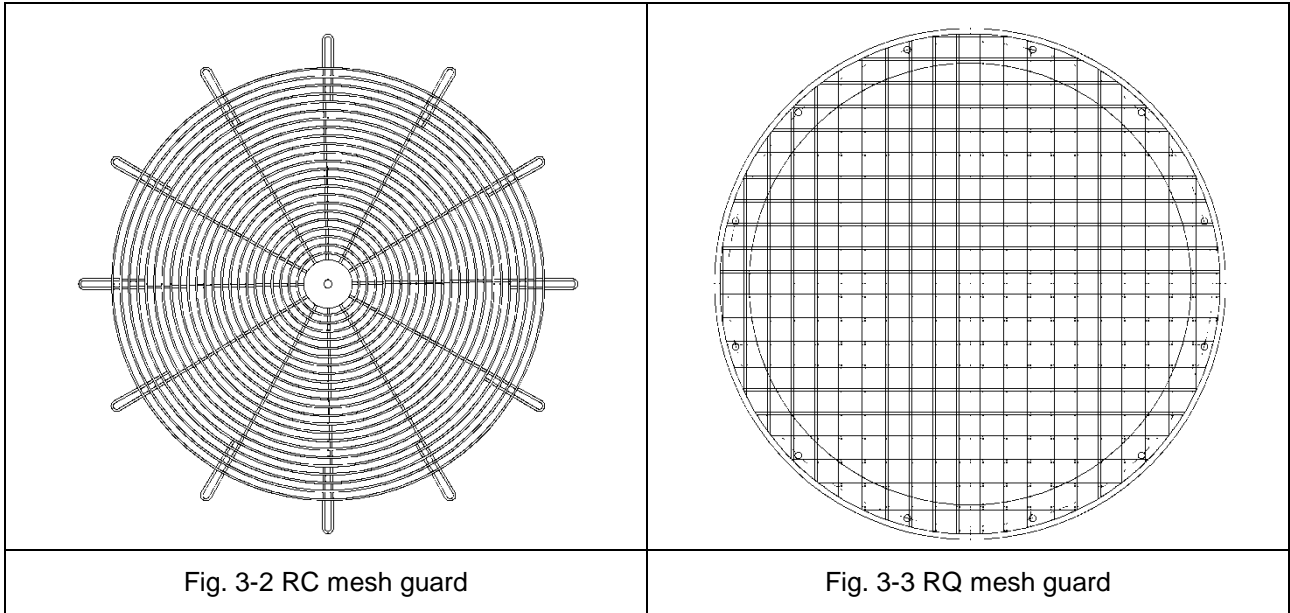


Fig. 3-1 BP mesh guard

An RC or RQ mesh must be bolted to the fan intake, depending on the fan size and series (see Fig. 3-2 and Fig. 3-3).

The type and number of nuts or bolts necessary to fit the guards are shown in Chart 3-1 and Chart 3-2 and for tightening torques reference must always be made to Chart 12-1.


Assembly diagrams for RC, RQ and BP guards are shown in Fig. 3-4, Fig. 3-5, and Fig. 3-6 respectively.



3.3 Installation type B: Instructions for assembly, installation and connections

In case of type B installations, since the fan intake is free and the exit is connected to a duct, a guard must be fitted on the intake.

Guard dimensions can be obtained from the dimensional drawings given in catalogues, from scale and non-scale drawings downloadable from the reserved area of the website, or from any dimensional drawings provided as documentation together with the products supplied.

	<p>CAUTION:</p> <p><i>Guards are designed to protect against accidental contacts and to resist the pressures generated only by the fan to which they are fitted.</i></p> <p><i>Each guard, if supplied individually, can be used only on the fan for which it was designed. If therefore a guard is ordered individually, it is compulsory to provide the reference details of the fan to which it will be fitted (serial number).</i></p>
---	---

A series RC or RQ mesh guard must be bolted to the intake, according to fan size and series (see Fig. 3-2 and Fig. 3-3).


The type and number of nuts or bolts necessary to fit the guards are shown in Chart 3-1 and Chart 3-2, and for tightening torques reference must always be made to Chart 12-1.

Assembly diagrams for RC and RQ guards are shown in Fig. 3-4 and Fig. 3-5 respectively.

3.4 Installation type C: Instructions for assembly, installation and connections

In case of type C installations, since the fan intake is connected to a duct and the exit is free, a guard must be fitted on the exit.

Guard dimensions can be obtained from the dimensional drawings given in catalogues, from scale and non-scale drawings downloadable from the reserved area of the website, or from any dimensional drawings provided as documentation together with the products supplied.

	<p>CAUTION:</p> <p><i>Guards are designed to protect against accidental contacts and to resist the pressures generated only by the fan to which they are fitted.</i></p> <p><i>Each guard, if supplied individually, can be used only on the fan for which it was designed. If therefore a guard is ordered individually, it is compulsory to provide the reference details of the fan to which it will be fitted (serial number).</i></p>
---	---

A BP guard must be bolted to the fan exit, composed of a mesh with square apertures welded to a flange with the same dimensions as the exit flange of the fan (see Fig. 3-1).

The type and number of bolts necessary are shown in Chart 3-3 and tightening torques are shown in Chart 12-1

The assembly diagram for BP guards is shown in Fig. 3-6.

3.5 Assembly and fastener diagrams for fixing guards RC, RQ and BP

Depending on fan size, RC/RQ guards can be fitted to intakes by using studs or bolts as shown in Fig. 3-4 and Fig. 3-5.

The fasteners necessary are shown in Chart 3-1 and Chart 3-2 respectively.

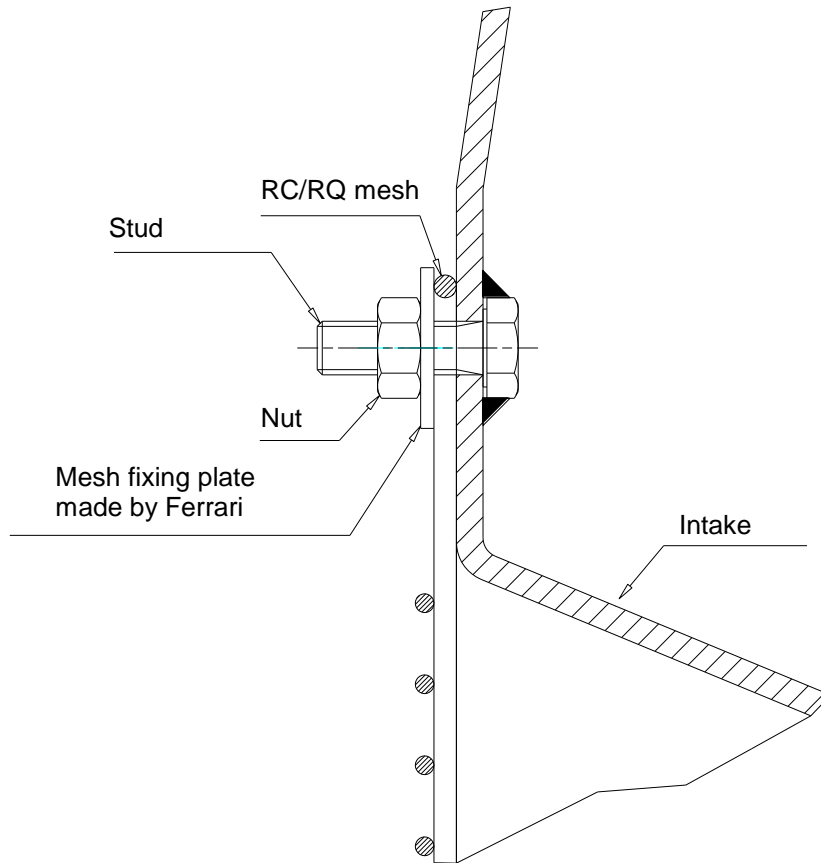


Fig. 3-4 Assembly diagram for RC or RQ mesh guards on intake studs

FLANGE	NUT	No.
125	M6	4
140	M6	4
160	M6	4
180	M6	4
200	M6	4
224	M6	4
250	M8	4
280	M8	4
315	M8	4
355	M8	4
400	M8	4
450	M8	12
500	M8	12
560	M8	12
630	M8	12
710	M10	16
800	M10	16
900	M10	16
1000	M10	24
1120	M10	24
1250	M10	24
1400	M10	30
1600	M12	30
1800	M12	30
2000	M12	30

Chart 3-1 Dimensions and number of fixing nuts for RC and RQ mesh guards on studs

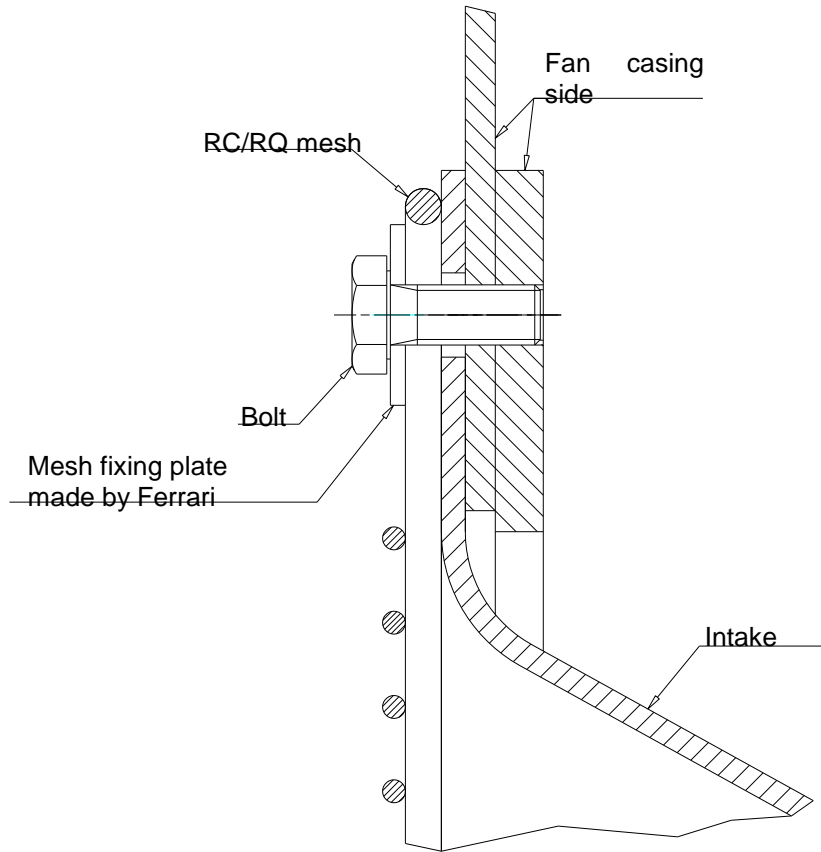


Fig. 3-5 Assembly diagram for RC or RQ mesh guards on threaded holes in casing

FLANGE	BOLTS *	No.
1120	M10	24
1250	M10	24
1400	M10	30
1600	M12	30
1800	M12	30
2000	M12	30

* Bolt length depends on mesh model and fan model

Chart 3-2 Dimensions and number of fixing bolts for RC and RQ mesh guards for threaded holes in casing

The BP mesh guard is fitted on the exit as shown here:

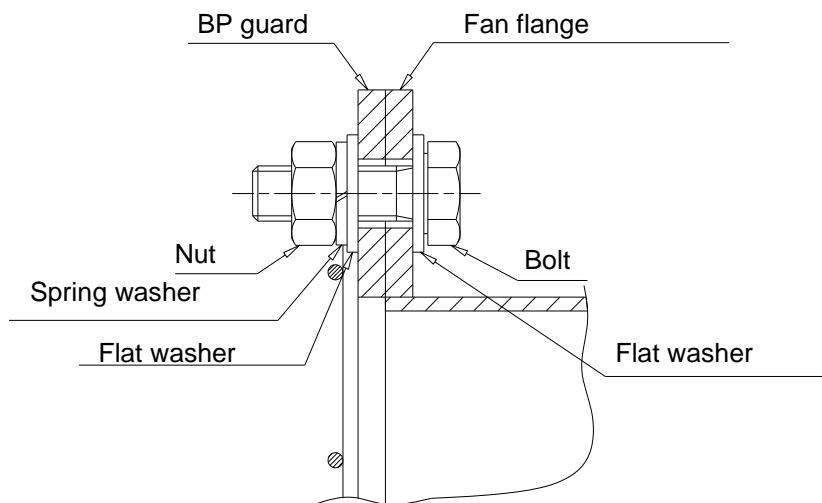


Fig. 3-6 Assembly diagram for BP guard

FLANGE	BOLTS	No.
90x63	M8x25	4
100x71	M8x25	4
112x80	M8x25	4
125x90	M8x25	6
140x100	M10x30	6
160x112	M10x30	6
180x125	M10x30	6
200x140	M10x30	8
224x160	M10x30	8
250x180	M10x30	10
280x200	M10x30	10
315x224	M10x30	10
355x250	M10x30	10
400x280	M10x30	14
450x315	M10x30	14
500x355	M10x30	14
560x400	M12x40	14
630x450	M12x40	14
710x500	M12x40	16
800x560	M12x45	14
900x630	M12x45	18
1000x710	M12x45	18
1120x800	M16x50	20
1250x900	M16x50	24
1400x1000	M16x50	24
1600x1120	M20x60	28
1800x1250	M20x60	32
2000x1400	M20x60	34
2240x1600	M20x60	40
2500x1800	M20x60	44
2800x2000	M20x60	48

Chart 3-3 Dimensions and number of fixing bolts for BP guard

Correct assembly:



OK




NO




Check that the guard is in the correct direction.

3.6 Installation type D: Instructions for assembly, installation and connections

In case of type D installations, since both the fan intake and exit are connected to ducts, no guards need to be installed on either the intake or exit of the fan.

	<p>CAUTION:</p> <p><i>The system designer must assess the need to fit any necessary guards at the intake and exit ends of the system.</i></p>
---	--


	<p><i>For installation types B, C and D, it is advisable to insert an anti-vibration joint between the fan and ducts so as to compensate for any misalignments that may be present, to prevent the transmission of vibrations and to avoid structural stress.</i></p>
---	---

The choice of a standard anti-vibration joint for applications that are not particularly difficult depends on two fundamental factors:

- dust content of the fluid moved
- fluid temperature

Clean air	Type 2 joint < 60°C without anti-wear strip	Type 3 joint <300°C without anti-wear strip
Dusty air	Type 5 joint < 60°C with anti-wear strip	Type 6 joint <300°C with anti-wear strip

Joints type 2, 3, 5 and 6 cannot be used on fans subject to the ATEX 2014/34/EC Directive.

	<p>CAUTION:</p> <p><i>Anti-vibration joints are suitable for installation on a single-stage fan, and must not be subjected to effects of fluid dynamics caused by other machines installed in the same fluid movement system.</i></p>
---	--

For special applications, such as for example the movement of fluids at a high temperature or that are particularly corrosive due to the presence of chemical compounds, or if it is necessary to guarantee perfect sealing of the joint, special joints must be used.

In this case the user and/or system designer must contact the **FVI** Technical Office.






3.7 Risks involved in foreseeable incorrect handling and/or abnormal uses based on experience

- When moving, lifting and installing the fan, always follow the instructions provided in this manual.
- It is absolutely prohibited to use the fan in conditions other than those indicated by the data on the identification plate.
- It is absolutely prohibited to deactivate, remove, modify or in any other way render inoperative safety devices, guards or control devices, either of individual components or of the fan itself.
- Do not position the hands, arms or any other part of the body near moving parts, even by forcing the opening of apertures.
- It is forbidden to extend parts of the body beyond protection structures. It is forbidden to use aids that may increase normal accessibility.
- It is forbidden to use fans in atmospheres or environments with the risk of explosions, with the exception of fans that are in conformity with the ATEX /EC Directive.
- It is forbidden for unauthorized operators to work on any fan defects or malfunctions or to alter the type of operation or installation.
- Great care must be taken to ensure that fluids with characteristics other than those defined in this manual (technical information sheet) are not introduced into fans.
- After all unprogrammed maintenance work involving the removals of guards, barriers or other protection devices, these must be replaced and checked for correct positioning and efficiency before the fan is started again.
- All guards and safety devices must be maintained in conditions of perfect and constant efficiency. Warning signs, safety symbols and danger warnings must be also maintained in perfect efficiency and in their correct position.
- When tracing the causes of any faults or malfunctions with fans, take all the precautions described in this manual, intended to prevent all and any kind of injury to persons or damage to things.
- Remember to tighten all bolts, nuts and fixing rings on all mechanical components that are adjusted or serviced, following the indications given in Chart 12-1.
- Before starting the fan, check that all guards and safety devices are installed and in perfect operating condition. If they are not, it is absolutely prohibited to start the fan. The person responsible for plant safety or the department head must be informed immediately.
- Operators must be provided with Personal Protection Equipment (PPE) in conformity with legal requirements, such as for example safety footwear, a protective helmet (if suspended loads are to be moved), work gloves, insulated footwear and gloves (in case of work on electrical components) and all other items of PPE required by specific safety regulations. Bulky garments and various accessories (ties, wide sleeves, etc) are prohibited.
- The fluid moved by the fan must be adequately checked for the possible presence of toxic and/or inflammable substances, even if their presence is not envisaged in the use of the fan.

3.8 Other risks related to fans pursuant to UNI EN ISO 12499

The specific risks defined below are those deriving from mechanical aspects of the fan.


  	<p>A person may be injured as a result of:</p> <p>a) <i>being dragged between a moving part and a fixed part, for example a impeller and the casing or some other fixed part of the fan;</i></p> <p>b) <i>being dragged between two moving parts, for example a drive belt and a pulley;</i></p> <p>c) <i>being dragged into the fan through the air intake, with consequent contact with the shaft or impeller;</i></p> <p>d) <i>contact with a moving part, such as the impeller;</i></p> <p>e) <i>ejection from the fan exit of fragments deriving from the introduction of residual solids or liquids extraneous to the process, or deriving from the suction environment;</i></p> <p>f) <i>an object drawn into the fan mouth and ejected at high speed from the fan intake or exit;</i></p> <p>g) <i>structural defects of fan components;</i></p> <p>h) <i>contact with fan surfaces at dangerous temperatures, for example below -20°C or higher than +50°C;</i></p> <p>i) <i>when working with hot fluids, there may be losses of jets of hot fluid from the transmission shaft hole that may cause burns or scalds.</i></p> <p>j) <i>the potential harmfulness of the fluid being moved or the presence of substances that in case of leaks may be hazardous (toxic and/or inflammable);</i></p> <p>k) <i>a hazard deriving from motor overspeed, which may cause the breakage of machine parts;</i></p> <p>l) <i>the intake of air at abnormal temperatures higher than those recommended may cause structural deformations, malfunctions and hazards.</i></p>
---	--

3.8.1 Specific risks with fans during installation


- The user must provide a well-levelled fixing surface. Incorrect levelling may cause abnormal fan vibrations that over time could cause deformation and/or breakage, with the detachment of fan parts, representing a hazard for exposed persons that may even be fatal.
- The user must also arrange electrical connections for the fan casing or structure to the main electrical grounding system of the place of use, to prevent any formation and accumulation of static electricity.
- All guards installed must remain correctly connected to the fan with all relative fasteners (bolts, nuts, etc). The removal of one or more fixing points may impair the functionality and solid fixing of the guard.
- Fans supplied as standard versions **are not** intended for use in potentially explosive environments.
- The place of installation of the fan must be kept clean. Any spills of oil or water not due to the fan must be cleaned away as quickly as possible.
- The minimum installation distances defined in this manual must always be respected to guarantee correct operation and the absence of additional risks. Incorrect positioning could impair the correct operation of the fan.

3.8.2 Specific risks with fans during maintenance

- During maintenance and cleaning operations on the impeller, take great care with rotations of the impeller, which could cause trapping or cutting injuries against fixed parts of the casing.

	<p>CAUTION:</p> <p>Even when the power supply to a fan is interrupted, its rotating parts may still move, due to air passing through the fan, either naturally or from fluid currents generated by a fan located in other parts of the system of linked ducts, or due to the inertia of the impeller after the machine has been switched off. In this case as well, there may be the risk of trapping or cutting injuries against fixed parts of the casing.</p>
---	--

- A programmed maintenance schedule for the fan must be prepared and applied, so as to prevent mechanical failures or breakages caused by wear or inadequate maintenance (see paragraph 12.3).

	<p>CAUTION: IT IS ABSOLUTELY PROHIBITED TO:</p> <ul style="list-style-type: none"> • <i>Carry out any type of maintenance operation without having first checked that the fan impeller is effectively at a standstill. The impeller takes several minutes to stop after the drive system has been switched off.</i> • <i>Proceed with any type of maintenance operation on the fan (including lubrication) without having first disconnected it from the mains powers supply.</i> • <i>Clean the fan while it is operating.</i> • <i>Open fan guards or inspection hatches while it is operating.</i>
---	--

3.8.3 Environmental risks

FVI fans are designed to operate in and to withstand ordinary conditions of working environments.

The presence of:

- vibrations
- corrosive agents (dust, gas, fumes, mist)
- high temperatures
- condensation
- solid bodies
- abnormal turbulence
- currents of air
- voltage differences due to installation

can affect the lifespan of components, causing premature deterioration, above all with respect to guards.


Since it is impossible to establish all-inclusive criteria that can take into account all the possible combinations of these effects, it is advisable to implement a plan of periodical checks according to the effective deterioration noted, so that any variations in structural characteristics can be detected in subsequent checks.

3.8.4 Vibration risks

Vibrations are the main factor affecting the operational life and safety of fans, and for this reason it is essential to accurately monitor their level during fan operation and work cycles.

The ISO 1940/1 and ISO 2372 international standards establish the field of acceptability and the classification of rotating machines, and more specifically, the ISO 14694 standard establishes values for industrial fans.

The reference values for FVI products are established by category BV3 of this standard.


	<p>CAUTION:</p> <p><i>Failure to check vibration levels may generate high risk factors and compromise the operative lifespan of the fan.</i></p>
---	---

If ignored, vibrations can:

- cause the formation of cracks serious enough to cause structural failure, which may even be sudden
- cause difficult operating conditions for bearings, with malfunctions that may even include seizing (with dangerous overheating effects)
- cause slackening of tightening and fixing components (nuts and bolts)
- generate greater noise.

FVI strongly recommends the use of a control and monitoring system for the fan, with continuous monitoring of vibrations and bearing temperatures.

Depending on the specific application and use of the fan, it is advisable to define an "alarm threshold" for fan vibration levels and bearing operating temperatures.


	<p><i>The monitoring of vibrations and temperatures makes it easier to take preventive actions against accidents.</i></p>
---	---


3.8.5 Operating speed risks

Operating speeds greater than those envisaged by the fan design can create conditions of risk due to the reduction of the operative lifespan of moving parts.

In case of faults or malfunctions, overspeed conditions may be created due to:


- Errors in the control logic system
- Short circuits on monitoring components
- Driver or inverter malfunctions
- Mechanical breakage of components, and in particular on encoder shafts.

	<p>CAUTION:</p> <ul style="list-style-type: none"> • <i>Do not exceed the maximum rotation speed indicated by FVI.</i> • <i>Do not use ON-OFF operating cycles unless expressly approved by FVI.</i> • <i>Do not use variable-speed cycles unless expressly approved by FVI.</i> • <i>Do not subject the fan to thermal gradients greater than 3°C/minute.</i>
---	---

	<p>CAUTION:</p> <p><i>A condition of overspeed, even for a limited time, may cause irreversible damage and create situations of extreme risk hazards. The maximum speeds indicated by FVI must never be exceeded.</i></p>
---	--


During normal operation, conditions of overspeed attributable to the drive system or motor may occur, in particular if the fan is supplied "with shaft only" or with motor "without drive system".


In these cases, it is the responsibility of the user to verify and guarantee the correctness of additional installations.


	<p>CAUTION:</p> <p><i>If the motor is operated with an inverter or an electronic speed control system, to prevent speeds in excess of those indicated by FVI, the control and monitoring circuit must be fitted with specific devices that detect, indicate and limit impeller rotation speed.</i></p>
---	---

The construction of the transmission by the user or installer is a critical point for safety.


The transmission is an integral part of the machine, and its construction requires a design process and awareness of the design parameters developed by **FVI**.

	<p>CAUTION:</p> <p><i>To construct the entire transmission and/or install the motor only, the user and/or installer must always request the transmission specifications document. It is absolutely prohibited to construct transmissions with the use of couplings, drive belts and pulleys of types other than those indicated by the transmission specifications document.</i></p>
---	---


	<p>CAUTION:</p> <p><i>If no inverter is used for gradual starting of the fan, it is absolutely prohibited to use toothed pulleys, as these can cause irreversible damage to fan structures. Consult the FVI Technical Office.</i></p>
---	---

	<p>CAUTION:</p> <p><i>Conditions of overspeed can be caused by drive system faults on fans with direct transmissions.</i></p>
---	--

In the case of directly-coupled fans of high power, starting is a moment of particular stress for rotating mechanical organs.


	<p>CAUTION:</p> <p><i>Above 15 kW, a gradual starting procedure must be used, to avoid overloading the transmission system and the impeller, with the consequent risk of breakages in these components.</i></p>
---	--


In the case of fans supplied without an electric motor, incorrect electrical connections to the motor or the wrong motor choice could be the cause of operation at speeds in excess of the original design speed, given that the rotation speed of an asynchronous motor depends on the frequency and the number of poles.

	<p>CAUTION:</p> <p><i>Fans are designed to be powered with a supply frequency of 50 Hz.</i></p> <p><i>The manufacturer must always be contacted in the case of use of a supply frequency other than the original design frequency. Do not proceed until authorized.</i></p>
---	--


The use of a supply frequency different from the original design frequency affects all fan characteristics. The modification of conditions of use requires a complete revision of the technical information sheet of the fan.

In the case of use at varying fan speeds or with frequent starting and stopping during operation, rotating organs are subject to mechanical stresses that may affect their operative lifespan.


	<p>CAUTION:</p> <p><i>In the case of fan operation with a variable speed cycle of less than 30 minutes, this cycle must be submitted to approval by the FVI Technical Office, which will give its approval and notify the consequent reduction of maintenance intervals and the fan lifespan.</i></p>
---	---

	<p>CAUTION:</p> <p><i>Fan operation within a very broad range of operating speeds may lead to increased vibration in correspondence with a specific resonance frequency of the system of which the fan is only a single component.</i></p> <p><i>Avoid working at speeds coinciding with structural resonance frequencies, and if this is not possible, modify some variable that can change the resonance frequency of the system, for example by using vibration dampers of a different type.</i></p>
---	--

If the rotation direction of a fan must be inverted, or if it must be restarted, this must be done only when the impeller is in the rest position (total standstill).


	<p>CAUTION:</p> <p><i>Inverting the fan rotation direction or starting it with the impeller turning in the opposite direction may cause breakage of the blades and/or the impeller hub, with the risk of ejection of metal parts.</i></p>
---	--

The replacement of moving parts with non-original spare parts may be the cause of different operating conditions with respect to the original design condition (e.g. AISI 304 stainless steel, AISI 316L stainless steel or Corten).

	<p>CAUTION:</p> <p><i>Respect the maximum speeds indicated in the catalogue for the applicable temperature. For impellers in stainless steel, these speeds must be reduced by 10%, and for transmission shafts in stainless steel by 20%. Comply with the information given on the transmission specifications document supplied with the fan.</i></p>
---	---

Operation at a speed significantly lower than up to 40% of nominal speed (unless otherwise specified by **FVI**) may affect the cooling of the motor and bearings, with possible malfunctions due to higher temperatures. For electrical components, the user and installer are advised to provide adequate protection for the drive system or motor, with the use of heat detection capsules if possible, and also using a servo-ventilated motor if necessary.

Resonance phenomena in the structure must be avoided. These may emerge at specific rotation speeds, and may cause damage to the structure.

	<p>CAUTION:</p> <p><i>Resonance phenomena at low frequencies may cause damage to the structure.</i></p>
---	--

3.8.6 Noise emission risks

FVI designs its fans dedicating attention to the elimination of the noise that they generate. Nevertheless, during normal operation fans act as a sound source.

The spectrum of frequencies of acoustic emission depends on the dimensional and structural characteristics of the fan, and also on its application of use (rotation speed, fluid moved, etc).

FVI, in collaboration with TUV, has measured the acoustic emissions of its fans in its own test laboratory in accordance with the EN ISO 3744 – EN ISO 3746 – ISO 13347 standards.

Tests were conducted with fans similar to those to which this manual refers, and relative values of acoustic power and pressure are shown in Chart 3-4, Chart 3-5, Chart 3-6 and Chart 3-7.

	<p>CAUTION:</p> <p><i>Vibrations and noise emission are directly correlated. Compliance with the instructions given for correct installation so as to reduce vibrations to a minimum is of equivalent importance for noise reduction.</i></p>
--	--

Since the noise emitted by a fan can be influenced by external factors that can affect the overall noise level, such as:

- the dimensions of the environment in which the fan is installed
- the presence of static elements near the fan (e.g. walls)
- the presence of other machines that are also sources of noise emission

FVI invites the user to measure ambient noise levels. It should be noted that the presence of other operating machines generates a "superimposition of effects" and resonance that multiply ambient noise.

In addition, in cases of restricted environments, or if the fan is installed against walls, the effect of reverberation and resonance on structures (walls and ceiling) is "exponential".

	<p>CAUTION:</p> <p><i>Avoid positioning fans in areas that could increase the noise risk.</i></p>
--	--

The definition of the risks to workers of exposure to noise is not the responsibility of **FVI**, which limits itself to indications of values, levels of uncertainty, standards or criteria used for noise emission measurements.

As envisaged by applicable legislation, it is the user that must assess the level of exposure of operatives to noise emissions using its own specific procedures, identifying:

- sources of noise and their relative importance
- average exposure times for each operative
- the level of direct and reflected noise
- the noise transmitted by structures and not through the air

	<p>CAUTION:</p> <p><i>Avoid working positions that increase the noise risk for operatives.</i></p>
--	---

	<p>CAUTION:</p> <p><i>Reducing exposure times and the use of Personal Protection Equipment will reduce the risks caused by exposure to noise emissions.</i></p>
--	--

If exposure to noise, in terms of sound pressure, exceeds 80 dBA, the employer must provide operatives with PPE for the hearing, such as earplugs or earmuffs. If exposure is equal to or higher than 85 dBA, the employer must take all possible action to ensure that PPE for the hearing is effectively used.



CAUTION:

With sound pressures higher than 100 dBA, operatives may approach the fan only if it is not operating, even if wearing Personal Protection Equipment.

3.8.7 General information on noise emission data

Level of acoustic power – L_{wA}

This is the average value of acoustic power expressed in dBA (value weighted according to scale A) emitted into the environment by a fan with ducting on both the intake and exit sides.

The value refers to channelled air with a density of 1.226 kg/m³, at the maximum permitted rotation speed of the impeller and with operation at the optimum point on the curve.

It is assumed that the fan is positioned in a free space, or in an area of dimensions such as to not cause significant reflection, and resting on a flat and rigid surface.

The possible contribution to the overall noise level of the noise caused by the motor, the transmission system and any accessories that may be present is not considered.

In addition, the value of background noise of the installation environment is not considered to be significant.

Level of acoustic pressure – L_{pA}

This is the average of the average temporal values of acoustic pressure emitted into the environment by a fan with ducting on both the intake and exit sides.

Pressure values are recorded on the measurement surface surrounding the fan (parallelepiped measurement surface).

Sound pressure measurements are obtained experimentally with 8 microphones located on the reference surface at a height equivalent to the fan rotation axis (see Fig. 3-7).

The pressure value is expressed in dBA (value weighted according to scale A).

The value refers to channelled air with a density of 1.226 kg/m³, at the maximum permitted rotation speed of the impeller and with operation at the optimum point on the performance curve.

The measured values refer to a measurement distance of one metre.

It is assumed that the fan is positioned in a free space, or in an area of dimensions such as to not cause significant reflection, and resting on a flat and rigid surface.

The possible contribution to the overall noise level of the noise caused by the motor, the transmission system and any accessories that may be present is not considered.

In addition, the value of background noise of the installation environment is not considered to be significant.

The point at which maximum acoustic pressure is found normally corresponds to the exit duct (external to the ducting), and its value is 3–4% higher than the average value.

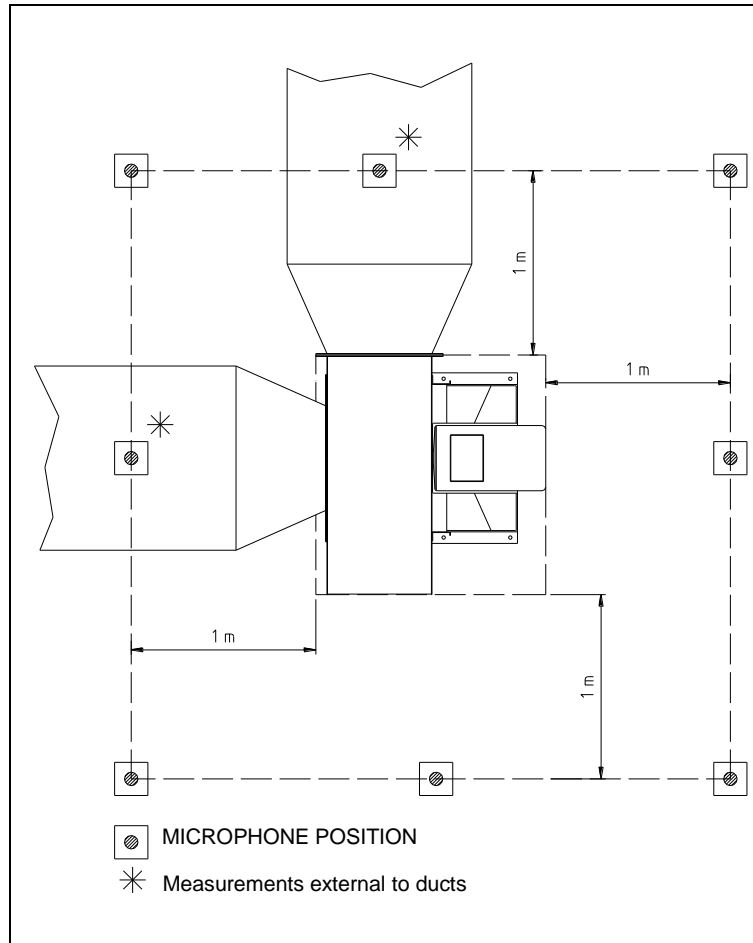


Fig. 3-7 Positions of measurement microphones

Reference standards

EN ISO 3744 - Determination of sound power levels of noise sources using sound pressure (engineering method in an essentially free field over a reflecting plane).

EN ISO 3746 - Determination of sound power levels of noise sources using sound pressure (survey method using an enveloping measurement surface over a reflecting plane).

ISO 13347 - Industrial fans - Determination of fan sound power level under standardized laboratory conditions.

ACOUSTIC POWER EMITTED Lw(A) (dBA) – Centrifugal fans													
Size	Series												
	FA/R	FC/P	FE/P	FG/P	FC/N	FE/N	FG/N	FI/N	FP/N	VCM	ART	FQ	MEC
221													94
251												87	95
281												90	96
311	83											92	97
351	85			94					94	94		94	97
401	88		92	95				96	96	97	103	97	98
451	90		95	98			96	99	98	98	106	98	99
501	92	93	96	99	91	94	97	100	101	101	107	101	100
561	94	97	99	102	94	97	100	103	103	103	107	103	100
631	96	98	101	104	96	99	102	105	106	105	108	106	102
711	99	101	104	107	99	102	105	108	108	107	109	106	102
801	102	103	106	109	101	104	107	110	111	111	110	108	104
901	103	106	109	112	104	107	110	113	112	112	111	108	105
1001		107			105	108	112	115		116	111	110	107
1121					109	112	114	116		116	112	110	107
1251							116	117		117	114	112	109
1401							116	118		117	114	112	109
1601							118	119		118	116	114	111
1801							118	120		119	116	116	111
2001							119	121		120	118	116	113

Uncertainty + 3 dB

Chart 3-4 Acoustic power emitted Lw(A) (dBA)



ACOUSTIC POWER EMITTED Lw(A) (dBA) Centrifugal fans

Size	Series												
	FR	TFR ¹	DFM	DFR	CFR	FS	K	KA	KB	KC	KM	PFB	PFM
181						97							
201						97							
221						97					96		
251	99					97					96		
281	100	77				98					97		
311	101	78				99	91				97		
351	101	83				100	93				98	102	95
401	103	87		106	104	101	97	105	108	105	99	105	100
451	104	89		106	104	102	99	105	108	106	100	110	104
501	106	94		107	103	103	101	106	109	107	100	113	108
561	104	99	106	109	104	102	103	107	110	107	101	100	111
631	106	92	108	110	104	105	105	108	111	109	103	105	115
711	106	96	108	110	102	105	108	108	111	109	103	109	102
801	108		109	112	104	107	110	110	113	110	105	113	106
901	109		109	112	104	107	111	110	113	112	108	118	110
1001	111		111	113	106	108		111	115	113	109	121	114
1121	111		111	112	105							114	117
1251	113		113	113								119	122
1401	113			112									
1601	115			113									
1801	115			114									
2001	117			115									

1) ducted only on intake side and at maximum synchronism speed

Uncertainty + 3 dB

Chart 3-5 Acoustic power emitted Lw(A) (dBA)

ACOUSTIC PRESSURE EMITTED Lp(A) (dBA) Centrifugal fans													
Size	Series												
	FA/R	FC/P	FE/P	FG/P	FC/N	FE/N	FG/N	FI/N	FP/N	VCM	ART	FQ	MEC
													81
251												74	82
281												76	82
311	70											78	83
351	72			80					80	80		80	83
401	74		78	81				82	82	83	89	82	84
451	76		81	84			82	85	83	84	91	83	84
501	78	79	82	85	77	80	83	86	86	87	92	86	85
561	80	82	84	87	79	82	85	88	88	88	92	87	85
631	82	83	86	89	81	84	87	90	90	90	92	90	86
711	84	86	89	92	84	87	90	93	92	92	93	90	86
801	87	87	90	93	85	88	91	94	94	95	94	91	87
901	88	90	93	96	88	91	94	97	95	96	94	91	88
1001		91			89	92	95	98		99	94	92	89
1121					92	95	97	99		99	94	92	89
1251							98	100		99	95	93	90
1401							98	100		99	95	93	90
1601							99	100		99	96	94	91
1801							99	101		100	96	95	91
2001							99	101		100	97	95	92

Uncertainty + 3 dB

Chart 3-6 Acoustic pressure emitted Lw(A) (dBA)

ACOUSTIC PRESSURE EMITTED Lp(A) (dBA) Centrifugal fans													
	Series												
Size	FR	TFR ¹	DFM	DFR	CFR	FS	K	KA	KB	KC	KM	PFB	PFM
181						84							
201						84							
221						84					83		
251	86					84					83		
281	86	64				84					83		
311	87	65				85	78				83		
351	87	69				86	80				84	83	76
401	88	73		92	91	86	83	91	94	91	85	86	80
451	89	75		91	89	87	85	91	94	91	85	90	83
501	91	80		92	89	88	87	92	95	92	85	93	87
561	89	84	89	93	89	87	89	92	95	92	86	77	90
631	90	77	92	94	88	89	91	93	96	93	87	81	94
711	90	81	92	94	87	89	93	93	96	93	87	85	79
801	91		92	95	87	90	95	94	97	94	88	89	83
901	92		92	95	87	90	96	94	97	95	91	93	86
1001	93		93	95	88	90		95	98	96	92	96	90
1121	93		93	94	87							89	93
1251	94		94	94								93	97
1401	94			93									
1601	95			93									
1801	95			93									
2001	96			94									

1) ducted only on intake side and at maximum synchronism speed
 Uncertainty + 3 dB

Chart 3-7 Acoustic pressure emitted Lw(A) (dBA)

4 TRANSPORT, MOVEMENT AND STORAGE

Lifting and movement operations with the fan may create hazardous situations for exposed persons. It is therefore advisable to follow the instructions provided by **FVI** and to use suitable equipment.

4.1 Lifting and movement

It is advisable to carry out all lifting and movement operations on the fan and its components with extreme care, avoiding impacts that may affect its correct operation or damage covered parts.

Use only the points indicated to lift the fan, distributing the load in a uniform manner.



Lifting points are identified with this symbol.



CAUTION:

The user assumes liability for the choice of the lifting equipment and ropes, straps or chains considered to be most suitable both for the purpose and for their lifting capacity. For lifting and movement, do not use zones or points other than those marked by a symbol.

4.2 General warnings for lifting separate fan parts

For reasons of transport, some fan parts may be delivered disassembled.



CAUTION:

- *All transport operations must be carried out only by qualified personnel, equipped with the correct PPE for protection against blows and/or falling object.*
- *The movement of separate or disassembled parts of the machine must be carried out with suitable means of transport.*
- *For the correct movement of these parts, respect the indications on weight provided by **FVI**.*



Generally, special or specific equipment is not necessary for the lifting of fan parts.

4.3 Fan lifting instructions

4.3.1 Lifting version 1-9-12 centrifugal fans

Lifting operations must be carried out by qualified personnel, suitably trained in the use of the equipment and equipped with the correct PPE for protection against blows and/or falling objects. Version 1 fans are supplied without motor. To lift them, the specific holes provided in the structure must be used (as shown in Fig. 4-1). These holes are located on opposite sides above the centre of gravity, and are indicated by specific symbols.

In this case it is advisable to use a chain sling with two arms, the choice of which by the user must be compatible with the weight of the fan. In particular, the user must ensure that the weight load limit (WLL) of the sling is equal to or greater than the load to be lifted.

Slings with several arms (3 or 4) used with a number of arms that is less than the total number of arms composing the sling must be used with a lower WLL than the WLL marked on the sling, applying the factors indicated by standard UNI EN ISO 818-6 - A.1.3.7. It is advisable for unused arms to be gathered and hooked together, to reduce the risk of them swinging freely or being caught up during movement of the load.

Every time that a sling is used, it must be inspected beforehand for possible damage or evident signs of wear.

To connect the sling to the load, it is preferable to use the method with straight arms. In this case, the lower ends are connected directly to the attachment point. The hooks must be chosen so as to ensure that the load settles at the centre of the hook, preventing the tip of the hook from being loaded. The hook tips must also be oriented outwards, unless the hooks have been specifically designed for being used otherwise.

Before operating the lifting equipment, it is advisable to check that the load is free to move, and that it is not blocked by connection components or other obstacles to movement.

It is advisable to keep the hands and other body parts away from the chains, to prevent injuries when they are put under load. When lifting operations are ready to start, any slack must be taken up before lifting itself can start. The load must be lifted slowly, checking that it is firmly secured and that it moves into the required position. Reference must also be made to standard ISO 12480-1 to plan and manage lifting operations and to ensure that a safe working system is used.

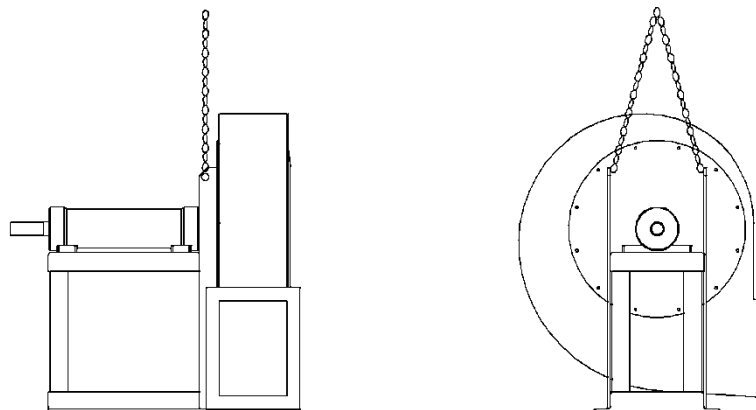


Fig. 4-1 Example of lifting version 1 centrifugal fans

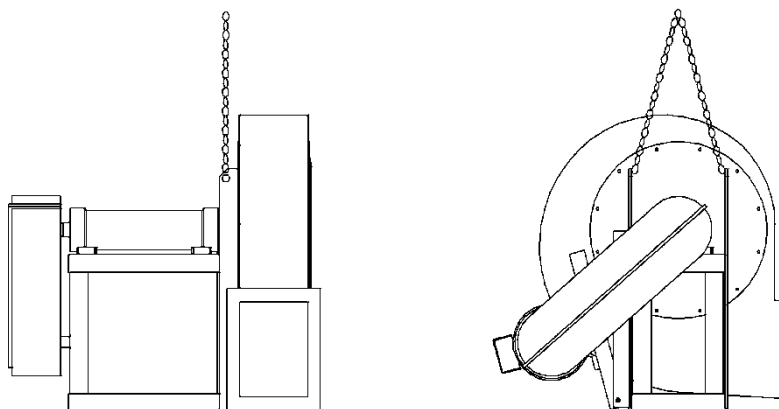


Fig. 4-2 Example of lifting version 9 centrifugal fans

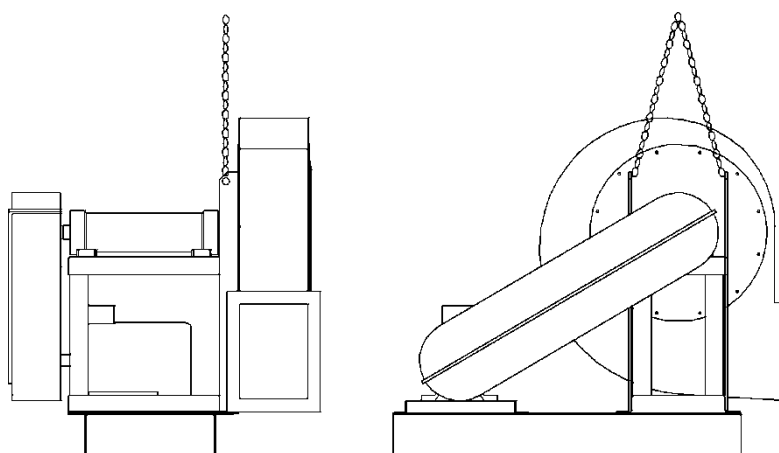


Fig. 4-3 Example of lifting version 12 centrifugal fans

4.3.2 Lifting version 4 centrifugal fans

Version 4 fans are complete with motor. To lift them, only the specific holes provided in the structure should be used (as shown in Fig. 4-4). These holes are located on opposite sides above the centre of gravity, and are indicated by specific symbols.

For the criteria to be applied in lifting operations the instructions provided in paragraph 4.3.1 must be followed.

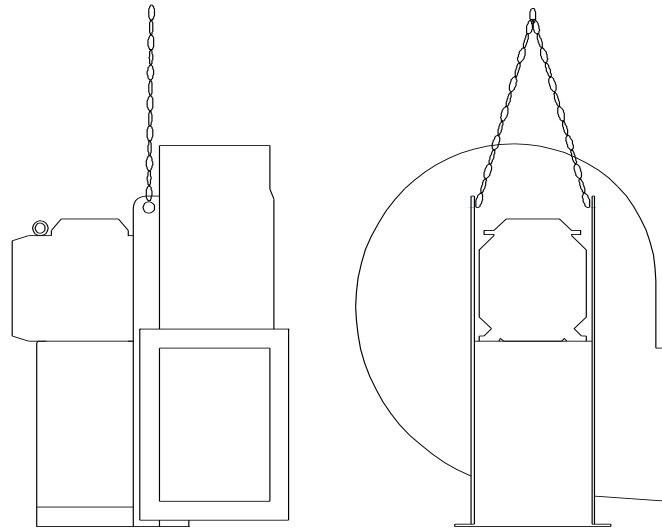


Fig. 4-4 Example of lifting version 4 centrifugal fans



CAUTION:

The lifting lugs on motors must never be used to lift the fan.

4.3.3 Lifting centrifugal fans with double intake

Fans with double intakes are complete with motor. To lift them, only the specific holes provided in the structure should be used (as shown in Fig. 4-5). These holes are distributed around the centre of gravity, and are indicated by specific symbols.

In this case, it is advisable to use a chain sling with four arms, the choice of which by the user must be compatible with the weight of the fan. In particular, the user must ensure that the weight load limit (WLL) of the sling is equal to or greater than the load to be lifted.

Although the general instructions on lifting methods given in paragraph 4.3.1 still apply, attention is drawn to the fact that since the lifting points are not located on the same level and are not symmetrically positioned with respect to the centre of gravity, the load could be asymmetrical.

In accordance however with standard UNI EN ISO 818-6, it can be assumed that the load is symmetrical if all the following conditions are satisfied:

- a) the load is less than 80% of the marked WLL;
- b) all angles of the arms of the chain sling with respect to the vertical are not less than 15°;
- c) all angles of the arms of the chain sling with respect to the vertical are included in an arc of 15° with respect to each other;
- d) in the case of slings with three or four arms, the flat angles are included in an arc of 15° with respect to each other.

If the conditions indicated above are not satisfied simultaneously, the load must be considered to be asymmetrical, and lifting must be assigned to an expert person for the identification of the safe load for the sling. Alternatively, in the case of an asymmetrical load, the maximum lifting load of the sling must be assumed to be equivalent to half of the marked WLL.

If the load tends to tilt, it must be lowered so that the hooking arrangement can be changed. This can be done by placing suitable shortening devices on one or more of the arms. Shortening devices must be used in accordance with the instructions provided by the manufacturer.

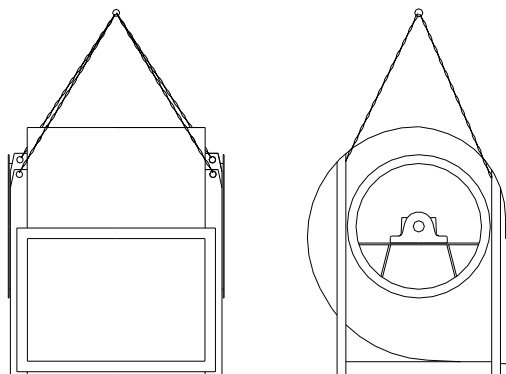


Fig. 4-5 Example of lifting centrifugal fans with double intake

In the case of fans with double intakes with a flexible coupling (version 17), if the lifting points are located not only on the casing but also on the end of the pedestal, lifting equipment complete with a spreader bar should be used (Figure 4-6).

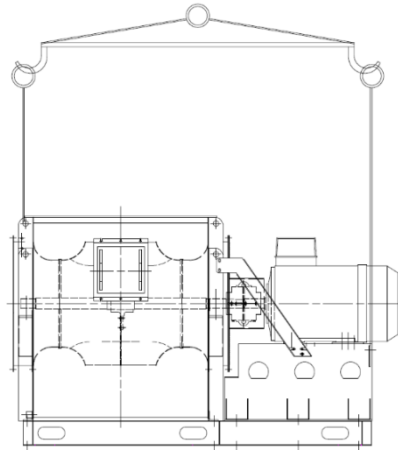


Fig. 4-6 Example of lifting for fans with double intakes with a flexible coupling

	<p>CAUTION: <i>The lifting lugs on motors must never be used to lift the fan.</i></p>
--	---

4.3.4 Lifting version 8 centrifugal fans

Version 8 fans are complete with motor. To lift them, only the specific holes provided in the structure should be used (as shown in Fig. 4-7).

The lifting symbols are located near the holes in the structure most suitable to balance the weight of the fan.

For the criteria to be applied in lifting operations the instructions provided in paragraph **Error! Reference source not found.** must be followed, even in case of lifting holes at the end of the pedestal (lifting with a spreader bar).

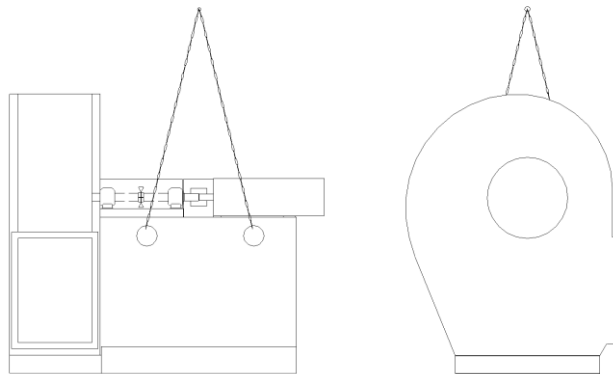


Fig. 4-7 Example of lifting version 8 centrifugal fans

	<p>CAUTION: <i>The lifting lugs on motors must never be used to lift the fan.</i></p>
--	---

4.3.5 Lifting fans packed in crate


The weight and centre of gravity of the crate are indicated on the outside of the package.


The lifting points for lifting the crate with a forklift truck are identified by two black triangles with the tip pointing downwards.

FVI ensures the stability of the fan or of fan components inside the case by means of rigid connections linked directly to the packing, so as to prevent any possible sudden movements of crate contents.

Nevertheless, while moving a crate with a forklift truck, the risk of instability or of the loss of stability caused by unforeseen movements of the forklift remains. To avoid this risk caused by unforeseen movements, care must be taken to carry out movement operations on a flat surface without projections or holes that could affect the stability of the loaded forklift truck. The speed of the forklift truck must also be reduced to a minimum, with the load at the minimum possible height.

Since the stability of the load is ensured when the position of the centre of gravity is located at a lower height vertically than the lifting point, whenever possible it is preferable to lift crates using lifting straps and/or chains.

	<p>CAUTION:</p> <p><i>Before lifting check:</i></p> <ul style="list-style-type: none"> • <i>that the capacity of the lifting equipment is compatible with the load</i> • <i>that the lifting equipment is in good condition</i> • <i>that the load has been correctly hooked up in safety</i> • <i>that the lifting point is vertically above the centre of gravity of the load</i> • <i>that the operator who carried out hooking up operations has moved away from the lifting areas</i>
---	--

	<p>CAUTION:</p> <p><i>Positioning of the lifting point at a significant distance from the vertical of the centre of gravity of the load can generate dangerous oscillations of the load when lifted.</i></p>
---	---

The load must be lifted away from the support surface with a very slow initial movement, so as to be able to identify any potential oscillations of the load. If residual oscillations of a nature that could be a hazard for persons or things during transport of the load are present after lifting it away from the support surface, it is advisable to wait for these oscillations to stop before starting transport operations.

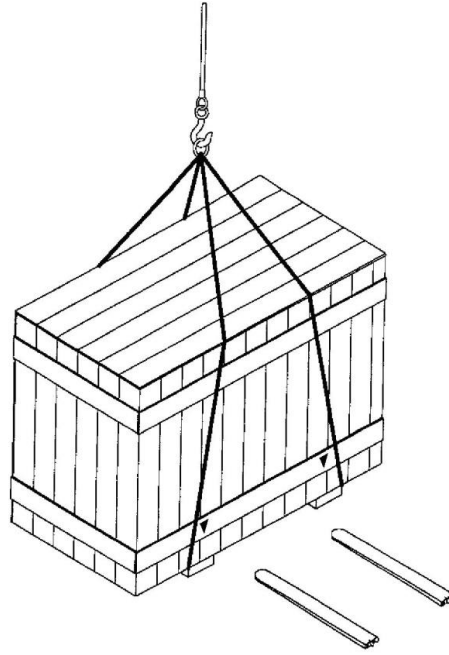


Fig. 4-8 Example of lifting fans packed in crate

4.4 Storage

If the fan is to be stored, it must be protected against weather conditions and damp, dust and the effects of atmospheric and environmental agents.



CAUTION:

Close intake and exit openings during storage.

It is advisable to periodically check the satisfactory state of conservation of the fan, and to manually rotate the impeller about once a month to prevent deformations to bearings.

5 INSTALLATION

5.1 General information



CAUTION:

All assembly operations must be carried out only by qualified personnel, equipped with the correct PPE for protection against blows and/or falling objects.



Generally, special or specific equipment is not necessary for the assembly of fan parts.

*In the case of assembly of parts requiring a specific procedure, **FVI** will provide the additional information necessary for carrying out the operations correctly.*

Special foundations are not necessary for positioning the fan. A well-levelled concrete support surface is sufficient, suitable to withstand the weight load of the fan and the dynamic stresses generated by its normal operation.

FVI designs and constructs its fans dedicating the greatest possible attention to the elimination of vibrations at their source. During installation, the user and/or installer must take the necessary measures to reduce vibrations from the overall system (fan and ducts).



It is advisable to use anti-vibration supports and joints to reduce to a minimum the transmission of vibrations during fan operation.



It is advisable to fix the fan using the specific fixing points provided, so as to prevent the fan from turning over or moving during starting.

The support surface must be flat and horizontal, to prevent the bending and misalignment of supports. If necessary, suitable metal spacers must be placed between the fan base and the support surface to ensure perfect adherence. Use the fixing points provided, ensuring that the tightening of nuts and bolts does not deform fan structures.

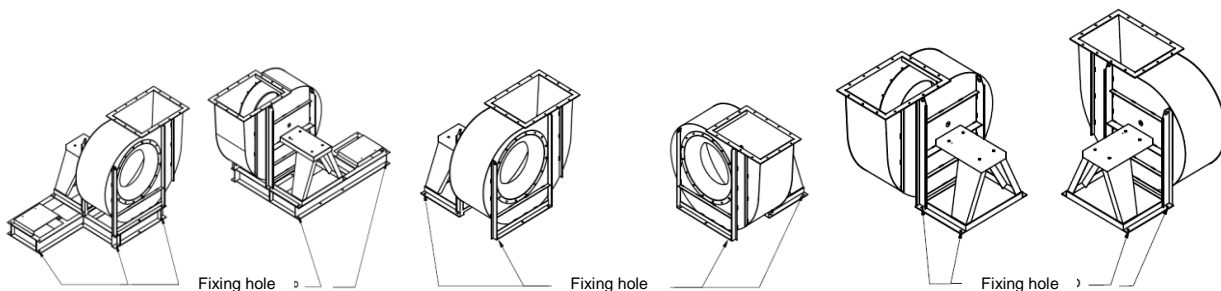


Fig. 5-1 Examples of fan fixing points

The support surface must be sufficiently rigid to withstand normal fan vibrations, and must not be subject to phenomena of structural resonance.


If the fan is mounted on a structure raised above floor level, the vibration characteristics of this structure must be verified.

The necessary and sufficient parameters for the definition of the technical characteristics of the support structure to be used for fan installation are as follows:


- static load of the fan
- dynamic load of the fan
- position of the centre of gravity of the fan


These data are given in the SCHT01 technical information sheet supplied together with the fan described in this manual, or in the overall dimensions drawing.


The same information sheet also gives technical data for the type of vibration dampers and anti-vibration joints to be used.

	<p>FVI does <i>not</i> consider fixing by means of welding the fan structure to foundation plates to be an acceptable fixing method.</p>
---	---

Ducting connected to the fan must be supported separately, and must be coaxial with respect to the intake and exit openings, so as to prevent deformation caused by the tightening of nuts and bolts.

	<p>CAUTION:</p> <p><i>All installation operations must be carried out only by qualified personnel, authorized, using suitable equipment and equipped with the correct PPE for protection against blows and/or falling objects.</i></p>
---	---

	<p>CAUTION:</p> <p><i>During installation, the conservation of the minimum access spaces requested for maintenance operations must be verified.</i></p>
---	--

	<p>CAUTION:</p> <p><i>Remember that version 5 fans are usually installed with a vertical axis. Other types of installation must be approved in advance by the FVI Technical Office (see paragraph 2.2.1).</i></p>
---	--

5.1.1 Minimum installation distances

If possible in the available space, to guarantee correct entry of the fluid into the intake opening it is advisable on fans connected to ducting to leave a straight section of duct with a length about 2.5 times the fan size (given on the identification plate). The result of this calculation divided by 1000 gives the recommended length (in metres).

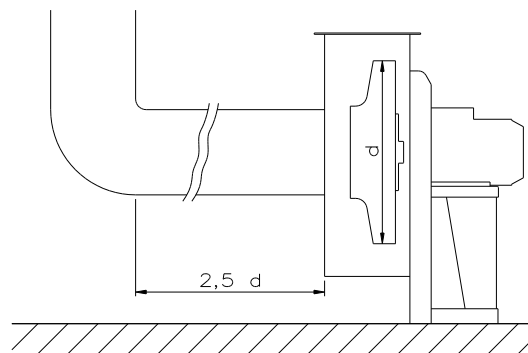


Fig. 5-2 Minimum installation distances with intake duct

If the fan is installed with a free intake opening, it must be positioned at a minimum distance from walls or other machinery of 1.5 times the fan size (given on the identification plate). The result of this calculation divided by 1000 gives the recommended minimum distance (in metres).

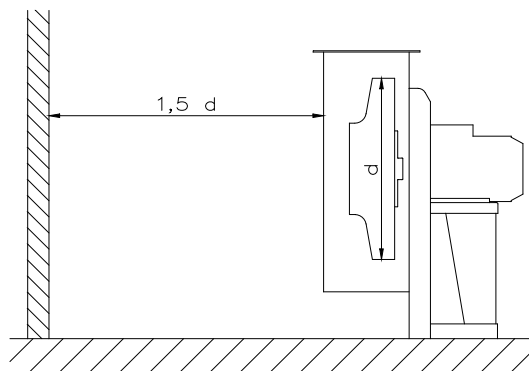


Fig. 5-3 Minimum installation distances with free intake



 	<p>CAUTION:</p> <p><i>The access of personnel, even if qualified, to the intake area of fans capable of developing, with zero flow, a negative pressure greater than 5000 Pa, must be prohibited.</i></p>
------	--

5.2 Installation of centrifugal fans

5.2.1 Centrifugal fans with single intake

For version 1-8-9-12 fans delivered disassembled in two or more parts, proceed as follows (numbers refer to Fig. 5-4 for version 1-9-12 fans and Fig. 5-5 for version 8 fans):

Step	Operation	Description
1	Positioning of casing [1] (or of lower casing [1b], Fig. 5-5, if divided into two or more parts)	The casing must be positioned on the foundation in a way that prevents fixing with bolts from causing stresses or deformation, inserting spacers beneath support points if necessary.
2	Positioning of motor pedestal [2] (if separate from the casing)	Proceed as in step 1.
3	Positioning of supports [3] (except for version 4)	<p>FVI fans are fitted with one of the following types of support:</p> <p>Type ST single-piece supports con with ball bearings and/or roller bearings (see Chart 9-1).</p> <p>Type SN plummer-block supports with self-aligning ball bearings and/or spherical roller bearings (see Chart 9-2).</p> <p>When fitting the bearings onto the shaft, the following guidelines should be followed:</p> <p>for plummer-block supports with ball bearings or roller bearings, fit the bearings into the correct position on the shaft without fixing them.</p> <p>Position the lower part of the support onto the motor pedestal, inserting the fixing bolts without tightening them. Position the shaft so that the bearing fits into the recess provided in the support, and</p>

Step	Operation	Description
		<p>secure the bearing, checking residual clearance according to the values shown in Chart 8-3 and Chart 8-4, while fixing the tapered bushes. The caps on plummer-block supports are not interchangeable. Finally, secure the supports to the pedestal by tightening the fasteners.</p> <p>The position of the supports must permit shaft levelling and the respect of the correct distance between the impeller and the intake (see step 7).</p>
4	Fitting impeller onto shaft [4]	<p>Check that all coupling surfaces are free from burrs or defects, which must be removed if present with a fine file or emery cloth. Check shaft diameter.</p> <p></p> <p><i>If necessary, reduce the diameter of the motor shaft until its nominal size is reached with a tolerance of +0/+5 microns. Assembly with excessive play can cause vibrations. Forced assembly creates deformations and vibrations, also making it more difficult to remove the impeller.</i></p> <p>Fit the spline into the slot provided and lubricate shaft surfaces with a thin layer of grease. Fit the impeller, checking that it is perpendicular to the axis of the motor or support shaft. It is essential for this operation to be done without encountering resistance, and using only the force applied by the fixing bolt. Do not fully tighten the bolt on the sleeve until final alignment has been checked.</p>
5	Completion of assembly of casing (only for casings in two or more parts: e.g. [1a] in Fig. 5-5)	<p>This must be done after assembly of the impeller. Spread adhesive on the contact surfaces and position the sealing cord (both supplied with the fan). Position casing parts, tightening all bolts.</p> <p></p> <p><i>When positioning the impeller, take care to avoid violent impacts, as these could affect impeller balance.</i></p>
6	Assembling intake [5] (only for fans with this feature)	<p>The intake must be secured between the side of the casing and the flange of the intake duct. It can be moved both horizontally and vertically to obtain optimum centring with respect to the impeller (see paragraph 10.1.2 in Fig. 10-1, Fig. 10-2 and Fig. 10-3).</p> <p>Fasteners must be fully tightened only after the intake has been centred with respect to the impeller, also rotating the impeller by hand to ensure that there are no contacts between parts. For fans with a separate motor pedestal that operate at high temperature (higher than 300°C), the minimum clearance possible must be obtained beneath the lower part of the intake and the impeller disk.</p> <p>On the intake of fans with a casing divided in two parts and on series FR, FS and DFR fans, if installed directly by FVI, after the intake has been centred, Allen screws are inserted as a reference, to facilitate correct centring after any necessary dismantling and reassembly operations.</p>
7	Levelling of shaft (except for version 4)	<p>This check must be done after all fixing fasteners have been fully tightened.</p>



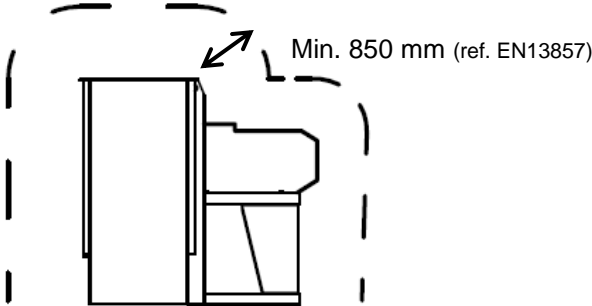
Step	Operation	Description
		 <p>IMPORTANT:</p> <p><i>For fans with a separate motor pedestal intended for high temperature operation (over 300°C), the fasteners anchoring the casing to the pedestal must be definitively tightened only when operating temperature has been reached.</i></p> <p>Check that the shaft is perpendicular to the casing, and that it is level. Check the exact and constant distance between the impeller and the intake. Precise positioning is obtained by lifting and slightly moving the supports. All bearings are self-aligning, but for perfect fan operation and adequate sealing of gaskets, the shaft must be sufficiently centred in the seats of plummer-block supports.</p>
8a	Assembling pulleys and belts for version 1, 9 and 12 fans [6, Fig. 5-4] and setting belt tension (except for version 4 fans)	Only for version 1, 9 and 12 fans: see Fig. 5-4. Detailed operations are described in paragraph 5.3 and paragraph 10.4. Then see paragraph 8.4 for belt tensioning instructions.
8b	Assembly of flexible coupling [6, Fig. 5-5] for version 8 fans and respective adjustments	Only for version 8 fans: see Fig. 5-5. For details on the operations to be carried out, refer to the specific instructions provided by the manufacturer of the coupling, which are part of the documentation supplied by FVI together with the fan.
9	 <p>For fans operating at high temperatures, it may be necessary to fit guards that prevent contact with surfaces with temperatures > 70°C</p>	
10	Assembly of any connection brackets between the casing and the pedestal for version 8 fans [7, 8 Fig. 5-5]	Proceed to fit the brackets, lining up their fixing holes with the holes in the pedestal. After fitting, the assembly must resemble that shown in Photo 67 in paragraph 10.6.
11	Assembly of any support and coupling protections for version 8 fans [10, 11 Fig. 5-5]	Proceed to fit the protections, lining up their fixing holes with the holes in the pedestal

Chart 5-1 Assembly of version 1-8-9-12 fans

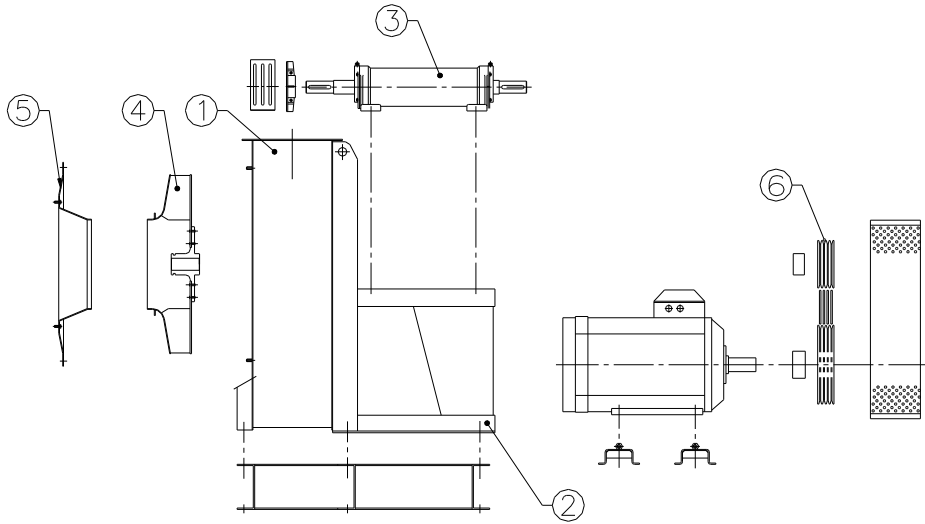


Fig. 5-4 Assembly of version 12 fans

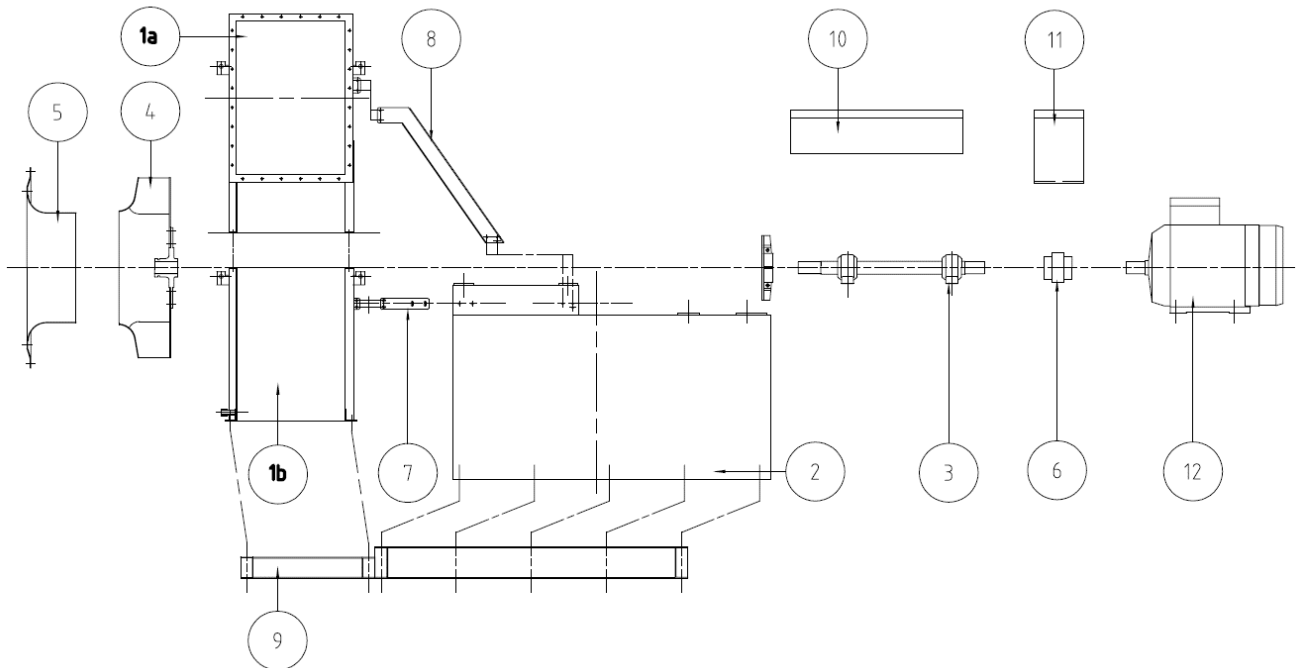


Fig. 5-5 Assembly of version 8 fans

5.2.2 Centrifugal fans with double intake

For version 6 fans, the assembly sequence is as follows (numbers refer to Fig. 5-6).


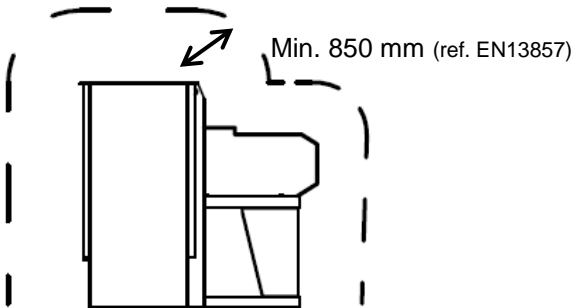
Step	Operation	Description
1	Positioning of casing [1] (or of lower casing if divided into two or more parts).	Proceed as in step 1 for centrifugal fans with single intake.
2	Completion of assembly of casing (only for casings in two or more parts)	Spread adhesive on the contact surfaces and position the sealing cord (both supplied with the fan). Position casing parts, tightening all bolts.
3	Positioning of intake [6] and support holder drum [7]	Fit these parts from the transmission side.
4	Positioning of supports on shaft [3]	Type SN plummer-block supports are always installed (follow the instructions given in step 3 for centrifugal fans with single intake).
5	Installation of shaft [8]	Fit the shaft into the casing with the impeller mounted.
6	Positioning of intake [9] and support holder drum [10]	Fit these parts from the side opposite to the transmission.
7	Levelling of shaft	Proceed as in step 7 for centrifugal fans with single intake.
8	Assembling pulleys and belts [11] and setting belt tension	Only for version 6 and 18 fans, see Fig. 5-6 and paragraph 8.4 for belt tensioning instructions.
9	 For fans operating at high temperatures, it may be necessary to fit guards that prevent contact with surfaces with temperatures > 70°C	

Chart 5-2 Assembly of centrifugal fans with double intake

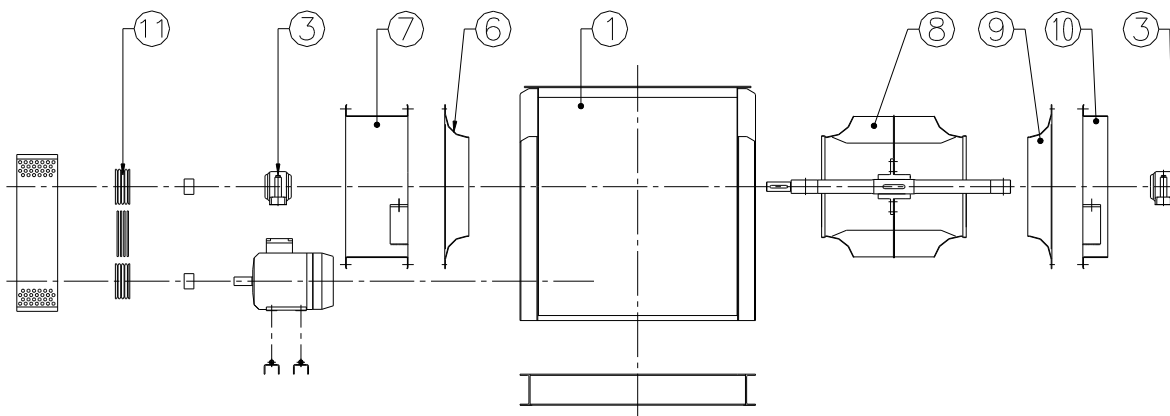


Fig. 5-6 Assembly of centrifugal fans with double intake


5.3 Installing and adjusting drive belts and final checks


If the fan is fitted with a **V-belt drive**, the transmission is assembled as follows:

- Carefully clean tapered parts and the bush hole before fitting it onto the pulley.
- Fit the bush onto the pulley, taking care to align the threaded half-holes on the pulley with the unthreaded half-holes on the bush.
- Screw in the grubscrews by hand without fully tightening them.
- Fit the assembly onto the shaft, after carefully cleaning it.
- Position the pulleys and check their alignment with a straight edge.
- Lock in place, tightening screws alternately.
- Fit the belts.
- Do not force the belts with a lever, to avoid damaging the fibres of the internal reinforcement.
- Before tensioning the belts, mark a known length on the taut side (e.g. 100 mm) and, rotating the transmission, gradually tension the belts (as described in paragraph 8.4) until a relative increase in length is obtained of:


0.8% for uniform torque;

1% for irregular torque.

	<p><i>Excessive belt tension may damage bearings and cause shaft breakage.</i></p>
---	--

	<p>CAUTION: <i>On transmissions with flexible couplings, alignment must be checked before starting the fan, as the motor pedestal</i></p>
---	--

5.4 Electrical connections

	<p>CAUTION:</p> <p><i>The fan is supplied in conformity with Directive 2014/30/EC on electromagnetic compatibility. In particular, the electric motor, if supplied with the fan, is guaranteed by its manufacturer to be conformant to this directive. It is the responsibility of the installer to check that the system in which the fan is inserted is conformant to the directive. If the motor is not supplied with the fan but is fitted by the customer, it is compulsory for the customer to check that it is conformant to the directive.</i></p>
---	---

The mains power supply line to the fan must be able to deliver sufficient power.

Connections to the mains power supply must be made by qualified personnel equipped with suitable PPE to protect against electrical hazards, remembering that the customer is always responsible for the electrical power supply through to the motor connection terminals.


Customers are reminded of the need to ensure all safety conditions for the grounding of the fan.

The grounding system must be conformant with applicable legislation in the country of installation, and must be regularly checked by qualified personnel.


Make the connection to the grounding connector before making all other connections.

Check that the connection layout (see Fig.) is suitable for the power supply voltage.

Standard electric motors can normally operate indifferently in both rotation directions. To invert the rotation direction, it is sufficient to exchange any two of the power supply cables directly on the terminal board.

	<p>CAUTION:</p> <p><i>It is the responsibility of the installer to provide an electrical power supply system for the fan in conformity with the EN 60204-1 standard.</i></p> <p><i>In particular, an electrical cut-off switch must be provided near the fan, so that maintenance personnel have direct control over power supply to the fan (see points 9.2.6.3 Enabling Control and 10.7 Emergency Stop Devices of the EN 60204-1 standard).</i></p>
---	---

In addition, the designer of the electrical system must provide controls for starting, normal stopping and emergency stopping, in conformity with Annex I of MACHINERY DIRECTIVE 2006/42/EC.

	<p>CAUTION:</p> <p><i>It is the responsibility of the customer and/or electrical installer to choose the correct size and type of the device and of cables used for electrical connections to the fan, depending on the motor installed and the mains power supply system.</i></p>
---	---

Work may be done on electrical components only with the fan at a standstill and disconnected from the electrical power supply.

Before installation and starting, check that the data on the motor identification plate are in conformity with the characteristics of the electrical power supply system.

The layouts shown are merely indicative. Consult the connection layout provided by the motor manufacturer.

Triple-phase single-speed motors	Triple-phase motors Single winding Single voltage	Triple-phase motors Two separate windings Single voltage
Delta connection	Dahlander or PAM connection for high speed	Connection for high speed
Star connection	Dahlander or PAM connection for low speed	Connection for low speed

Fig. 5-7 Diagram of electrical connections for one-speed and two-speed motors

5.5 Connection to ducts

The fan must be connected to ducting with all parts correctly aligned, without obstructions to air flow from gaskets or flexible components. The weight of ducting must not be supported by the fan, and deformations of parts of the machine by ducting connections must be avoided. Any flexible joints between the fan and intake and/or exit ducts must be installed in a way that prevents stress on flexible components, and that avoids contacts between metallic parts of the joints (see Fig. 5-8 for assembly tolerances).

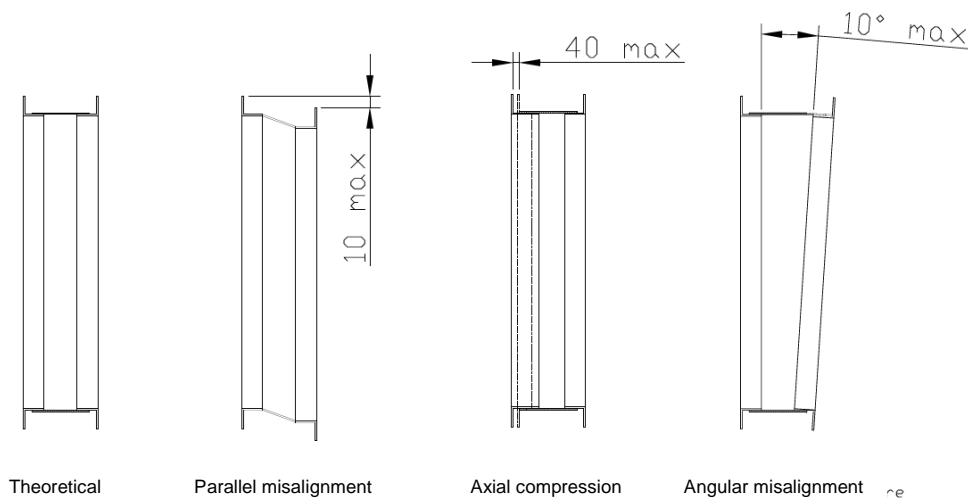


Fig. 5-8 Assembly tolerances for flexible joints

If possible in the available space, to guarantee correct entry of the fluid into the intake opening it is advisable on fans connected to ducting to leave a straight section of duct with a length about 2.5 times the fan size (given on the identification plate). The result of this calculation divided by 1000 gives the recommended length (in metres).

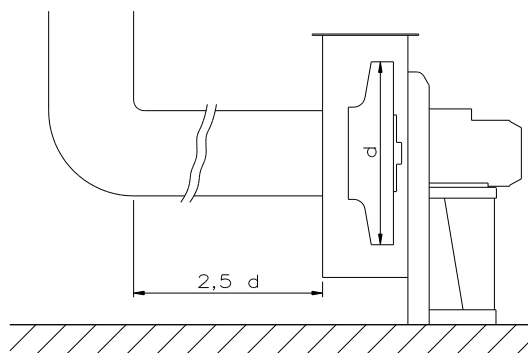


Fig. 5-9 Minimum installation distances with intake duct

6 CHECKS TO BE MADE BEFORE AND AFTER STARTING

6.1 Preliminary checks and first starting of the machine



CAUTION:

Preliminary checks before the first starting must be made only with the fan at a standstill and disconnected from electrical power supplies.

Before the fan is started for the first time a number of preliminary checks are necessary:

- Verify the compatibility of the fan for its intended application.
- In case of completion of the transmission by the installer, verify the compatibility of the fan identification plate with the transmission specifications document.
- Check that all guards are present.
- Check that all nuts, bolts and other fasteners envisaged by **FVI** are present.
- Check that all nuts, bolts and other fasteners (impeller, supports, foundation, transmission if present) are correctly tightened.
- Check the correct lubrication of the fan and motor bearings, and if necessary replace the grease (see Chapter 8 MAINTENANCE).
- Check that all rotating parts can turn freely.
- Check for the absence of objects or foreign bodies inside the fan.
- Starting the machine requires no particular operations other than the supply of electrical power to the motor. Always check that the supply voltage corresponds to the voltage envisaged for use of the machine and is compatible with the voltage indicated on the motor identification plate. In case of use with an inverter, the fan must be started by gradually varying the frequency of the inverter from zero up to the value envisaged for normal operating speed. The same procedure must also be used every time the machine is started subsequently.
- Check that the rotation direction is correct. A short burst of electrical power is sufficient to check that the rotation direction is the same as that indicated on the fan casing. If necessary invert the rotation direction (see paragraph 5.4 – Electrical connections).

FVI recommends the use of the checklist given in paragraph 12.2 to record the necessary checks for safety conditions.



CAUTION:

Operating trials must not be permitted before the checks of the checklist have been made (see paragraph 12.2).

6.2 Checks to be made with fan fully operating

Check that power absorption does not exceed the value indicated on the motor identification plate. If it does, **immediately halt the fan and contact the manufacturer.**

Fan operation must be free from excessive vibrations and abnormal noise.

With the fan at a standstill, check that the temperature of the bearings does not exceed the limits of tolerance (with an ambient temperature of 20°C, the temperature of supports must be no higher than 70°C). It must be taken into consideration that in the first hours of operation, a higher temperature than that indicated may be

normal, if it then falls to a lower value. In case of abnormal overheating of bearings, consult the **FVI** technical service.

After 3–4 hours of operation, with the fan at a standstill and disconnected from the power supply, repeat the checks on the tightness of nuts and bolts, bearing temperatures, and for fans with transmission, the temperature and tension of drive belts.

On request, **FVI** fans can be fitted with vibration and/or temperature sensors for support bearings (for fans with transmission). In this case, **FVI** installs the vibration sensor on the impeller side of the support, and the temperature probe on the transmission side of the support.

With regard to vibrations, the criterion for the verification of conditions of safety refers to standard ISO 14694:2003. Which recommends the following limits for mechanical vibrations (vibration speed in mm/s RMS), measured in installation conditions:

- **alarm: 7.1 (rigid), 11.8 (flexible);**
- **stop: 9 (rigid), 12.5 (flexible);**

These limits are considered to be valid by **FVI** in general, with the exception of specific indications for individual applications.

Measurement point and direction: on fan supports, in a direction perpendicular to the rotation axis, on the horizontal or vertical plane.

The use of the definition of rigid and flexible refers to the fact that the structure reaches its first critical speed higher or lower respectively than operating speed. **FVI** fans normally have a rigid structure with regard to this definition.

The reference limits for temperature on supports, measurable on the external bearing ring regardless of ambient temperature, are as follows:

- **alarm 100 °C;**
- **stop 120 °C;**

6.2.1 Visual checks on guards

For mesh guards, checks must be made for the following:

- Corrosion or dullness of galvanized surfaces
- Detachment of rivets/welds
- Evidence of noises typical of loose guards
- Impacts and permanent deformation of components
- Breakage of wires
- Corrosion of fasteners
- Slackening of fixing elements

For guards in pressed and painted sheet metal, checks must be made for the following:

- Corrosion or dullness of painted surfaces
- Detachment of rivets/welds
- Evidence of noises typical of loose guards
- Impacts and permanent deformation of components
- Mechanical deformation or breakage of guards
- Presence of cracks



- Corrosion of fasteners
- Slackening of fixing elements



CAUTION:

All guards must be inspected every month and replaced if necessary.



CAUTION:

In case of doubts, carry out checks more frequently or replace the guard.

6.2.2 Checking and cleaning parts in contact with fluids

The periodical cleaning of the impeller prevents vibrations that might be caused by any dust deposits that accumulate while the fan is running.

If the fan is used for the movement of even slightly dusty fluids containing abrasive dust, or for pneumatic transport, the impeller must be inspected periodically for cleanness and/or wear.

Deposits of material or wear on impeller parts may cause abnormal fan vibrations.

6.2.3 Visual inspections on blades and casing

Periodical visual checks must be made for wear on impeller blades, given that deterioration of these parts can create a condition of extreme risk, due to the ejection of the blade or the failure of structural components, with consequences that may even be fatal.

To monitor **phenomena of abrasion** on impeller blades and the casing, use a portable lamp to visually inspect components, slowly rotating the impeller to allow all blades to be seen. Blades must be totally free from damage and must show no signs of abrasion or missing sections.

With regard to the **phenomenon of corrosion** on impeller blades and the casing, corrosive and acidic environments can reduce the thickness of fan safety components.

This phenomenon must not be underestimated, also because it does not depend solely on the concentration of aggressive agents.

Condensation may form during pauses in fan operation, and this may accelerate the phenomenon of chemical corrosion, which in turn may alter the thickness of components, affecting their integrity.

6.2.4 Dimensional checks

CHECKLIST – DIMENSIONAL CHECKS ON COMPONENTS			
COMPONENTS TO CHECK	TYPE OF CHECK/INSTRUMENT	CRITERIA FOR ACCEPTABILITY	RESULT
Impeller: blade thickness	Dimension/Caliper	Reduction of thickness no greater than 10% in an area without wear or with paint undamaged	OK <input type="checkbox"/>
Impeller: thickness of impeller disk	Dimension/Caliper	Reduction of thickness no greater than 10% in an area without wear or with paint undamaged	OK <input type="checkbox"/>
Casing: thickness of sides and sheeting	Dimension/Caliper or equivalent	Reduction of thickness no greater than 10% in an area without wear	OK <input type="checkbox"/>
Intake: thickness	Dimension/Caliper	Reduction of thickness no greater than 20% in an area without wear or with paint undamaged	OK <input type="checkbox"/>
Anti-vibration joints: thickness of anti-wear sheeting (if present)	Dimension/Caliper	Reduction of thickness no greater than 20% in an area without wear or with paint undamaged	OK <input type="checkbox"/>
Welding (entire structure)	Visual	Absence of damage and cracks	OK <input type="checkbox"/>
Date:			
Signature:			

7 CENTRIFUGAL FAN OPERATING MALFUNCTIONS

7.1 Most frequent malfunctions

The following chart lists the main problems that may be encountered:

PROBLEM	CAUSE	SOLUTION
Fan does not start	No electrical connection	Check that the motor and/or command inverter to the electrical power supply line and is correctly powered
	Motor malfunction	Check internal connections and motor components and replace if necessary
	No connection between command inverter and motor	Check for correct connection between inverter and motor
	Command inverter malfunction	Check internal inverter circuits and components and replace if necessary
Power absorption much lower than design value	Rotation speed too low	Increase rotation speed
	Openings or ducting partially blocked	Eliminate obstruction Check the position of regulation organs
	Impeller partially blocked	Eliminate obstruction
	Resistance pressure of system lower than design value	Check the resistance pressure value of the system
	Fluid density lower than intended value	Check the fluid density value
High power absorption	Rotation speed too high	Reduce rotation speed
	Resistance pressure of system lower than design value	Check the resistance pressure value of the system
	Incorrect impeller rotation direction	Check impeller rotation direction and orientation
	Pre-rotation of air in opposite direction to fan rotation	Check minimum installation distances (paragraph 5.1.1) or correct orientation of intake with predistributors
	Fluid density higher than intended value	Check the fluid density value
	Power supply to motor with voltage lower than shown on identification plate	Check for correct voltage of power supply to motor
	Defects in motor windings	Check for correct motor operation
Insufficient pressure	Rotation speed too low	Increase rotation speed
	Fluid density lower than intended value	Check the fluid density value
	Air flow greater than intended value	Check the resistance pressure value of the system
Pulsating operation	Instability of air flow	Check operating field envisaged by operating curve
	Fluctuations in flow due to other fans operating in parallel	Check for correct installation on system
	Intake air turbulence created by system near intake opening	Check minimum installation distances (paragraph 5.1.1)

PROBLEM	CAUSE	SOLUTION
Vibrations	Pulsating operation	See previous point "Pulsating operation"
	Structural resonance at specific rotation speeds	Use the inverter to avoid operation at these speeds or modify frequencies of the overall system
	Wear on impeller parts	Inspect the impeller
	Deposit of material on impeller	Inspect the impeller
	Friction between moving parts	Check for correct coupling between moving parts
	Intrinsic bearing defects	Check condition of bearings
	Bearing malfunctions due to unbalanced impeller or excessive belt tension	Check condition of bearings Check belt tension (see paragraph 8.4)
Excessive noise	Friction between moving parts	Check for correct coupling between moving parts
	Vibrations	See previous point "Vibrations"
	Pulsating operation	See point "Pulsating operation"
	Electromagnetic motor malfunctions	Check for correct conditions of power supply to motor (inverter)
	Presence of holes or sharp projections	Check for presence of rounded projections in points with high air speed

8 MAINTENANCE



Read this section carefully before carrying out maintenance operations on the fan. This will ensure greater conditions of safety for maintenance personnel and greater reliability of the work done.

The safety rules to be respected during maintenance operations on the fan are as follows:

- Maintenance and/or lubrication operations must be carried out only by qualified and expert personnel, authorized by the technical management of the factory, in conformity with applicable safety directives and standards, using tools, equipment and products suitable for the purpose.
- During maintenance operations, suitable clothing must be worn, such as closely-fitting overalls and safety footwear, absolutely avoiding garments that are bulky or with loose parts.
- During maintenance operations on the fan, it is advisable to fence it off and to identify it with signs with the wording: "FAN UNDERGOING MAINTENANCE".



CAUTION:

The fan must be disconnected and isolated from the electrical power supply during maintenance operations. Always check that the impeller and motor are at a standstill before accessing the fan and its components or opening the inspection hatch.

In the case of fans that move hot fluids, wait for the fan to cool down before carrying out maintenance operations, so as to prevent contact with surfaces at high temperatures.

In the case of maintenance operations on rotating parts or parts inside ducts, it is also necessary:

- where present, to disconnect the flexible motor coupling;
- where present, to remove drive belts from pulleys.



CAUTION:

*In the case of use of a multi-stage fan, disconnect the electrical power supply **from the entire multi-stage fan** and check that the impeller is at a total standstill before carrying out any maintenance operation.*

The person responsible for maintenance must use a team of persons so as to guarantee absolute coordination between the persons and the maximum safety for persons exposed to risk. All persons preparing to carry out maintenance operations must be in full visual contact to warn of possible hazards.



CAUTION:

Any necessary movement of parts to be removed or disassembled from the machine must be made with suitable transport and lifting equipment.



Generally, special or specific equipment is not necessary for the fan maintenance operations.



Full systematic maintenance of the fan is necessary for its normal correct operation, and is also a factor of safety for operatives.

To facilitate the planning of programmed maintenance, **FVI** has compiled a chart (see paragraph 12.3) with general indications of the points to be monitored and the frequency of checks.

	<i>Periodic cleaning and maintenance, together with lubrication, are essential to ensure correct fan operation and a longer operative lifespan of the fan.</i>
--	--

8.1 Bearing lubrication

	<i>Both type SN and type ST supports assembled by Ferrari already contain the correct quantity of lubricant, as indicated in Chart 8-1. No lubricant filling operations are therefore required during installation.</i>
--	---

Check bearing lubrication at the recommended intervals.

The bearing installed in the supports of fans with transmission must be lubricated at the intervals and using the quantity of grease indicated in the transmission specifications document attached to the fan documentation, if the fan has been supplied complete with transmission. For version 1 or 6 fans (shaft only, without transmission), consult Chart 8-2 for the correct lubrication interval. Lubricate using the recommended type of grease or an equivalent type. If the fan operates in a dusty, damp, hot or corrosive environment, lubrication intervals must be reduced by approximately 40% or more with respect to the value indicated on the transmission specifications document, depending on the harshness of the operating environment.

	<i>An excessive quantity of lubricant causes bearing overheating. Avoid filling supports with a quantity of grease greater than that recommended.</i>
--	---

Unless otherwise indicated, the grease used in the bearings of **FVI** fans on delivery is:



SHELL GADUS S3 V100 2

This is a lithium-based soap complex, with a dropping point of 250°C (IP 396) and a cone penetration value at 25°C – 0.1 mm (IP 50/ ASTM D217) of 265–295. Kinematic viscosity (IP 71/ ASTM D445): at 40°C, 100 cSt; at 100°C, 11.3 cSt.

The following greases have comparable characteristics:

	S.R.I. GREASE 2
	ALETIUM GREASE 2
	MOBIPLEX 47
	RUBENS
	GP GREASE
	CERAN WR 2
	CASTROL SUPER GREASE 2

<i>Support type</i>	<i>Quantity of grease for first filling (g)</i>
SN 507 ...	50
SN 508 ...	60
SN 509 ...	65
SN 510 ...	75
SN 511 ...	100
SN 512 ...	150
SN 513 ...	180
SN 516 ...	280
SN 517 ...	330
SN 518 ...	430
SN 520 ...	630
SN 522 ...	850
SN 524 ...	1000
SN 526 ...	1100
SN 528 ...	1400
SN 530 ...	1700
ST ...	Fill the bearing completely but fill the free space in the support only partially

Chart 8-1 Quantity of grease for first filling of supports and bearings on fans with transmission



Bearings on motors up to the size of 160 are normally life-long lubricated, and therefore do not require lubrication.

Check and lubricate bearings at the intervals recommended by the motor manufacturer. It is always advisable to periodically substitute bearings with replacements as indicated on the motor identification plate.



Use the type of grease recommended by the motor manufacturer to lubricate motor bearings.

Support type	Bearing type (pulley side)	Rotation speed (RPM)					Grease quantity (grams)	Bearing type (side opposite pulley)	Rotation speed (RPM)					Grease quantity (grams)
		1060	1500	2120	3000	4250			1060	1500	2120	3000	4250	
		Relubrication intervals in hours							Relubrication intervals in hours					
ST 47 A-AL	6204 Z	12500	8000	6300	4000	3150	4	6204 Z	12500	8000	6300	4000	3150	4
ST 62 A-AL	6305 Z	11200	7100	5600	3550	2800	5	6305 Z	11200	7100	5600	3550	2800	5
ST 80 A-AL	6307 Z	10000	6300	5000	3150	2500	7	6307 Z	10000	6300	5000	3150	2500	7
ST 90 A-AL	6308 Z	9000	5600	4500	2800	2240	9	6308 Z	9000	5600	4500	2800	2240	9
ST 90 B-BL	NU 308 ECP	4500	2800	2250	1400	1120	9	6308 Z	9000	5600	4500	2800	2240	9
ST 100 A-AL	6309 Z	8000	5000	4000	2500	2000	11	6309 Z	8000	5000	4000	2500	2000	11
ST 100 B-BL	NU 309 ECP	4000	2500	2000	1250	1000	11	6309 Z	8000	5000	4000	2500	2000	11
ST 110 A-AL	6310 Z	7100	4500	3550	2240	1800	14	6310 Z	7100	4500	3550	2250	1800	14
ST 110 B-BL	NU 310 ECP	3550	2250	1800	1120	900	14	6310 Z	7100	4500	3550	2250	1800	14
ST 120 A-AL	6311 Z	6300	4000	3150	2000	1600	18	6311 Z	6300	4000	3150	2000	1600	18
ST 120 B-BL	NU 311 ECP	3150	2000	1600	1000	-	18	6311 Z	6300	4000	3150	2000	1600	18
ST 130 A-AL	6312 Z	5600	3550	2800	1800	-	22	6312 Z	5600	3550	2800	1800	-	22
ST 130 B-BL	NU 312 ECP	2800	1800	1400	900	-	22	6312 Z	5600	3550	2800	1800	-	22
ST 150 A-AL	6314 Z	5000	3150	2500	1600	-	28	6314 Z	5000	3150	2500	1600	-	28
ST 150 B-BL	NU 314 ECP	2500	1600	1250	800	-	28	6314 Z	5000	3150	2500	1600	-	28
ST 180 A-AL	6317	4500	2800	2240	1400	-	36	6317 Z	4500	2800	2240	1400	-	36
ST 180 B-BL	NU 317 ECP	2250	1400	1120	-	-	36	6317 Z	4500	2800	2240	1400	-	36
ST 200 A-AL	6319	4000	2500	2000	-	-	45	6319 Z	4000	2500	2000	-	-	45
ST 200 B-BL	NU 319 ECP	2000	1250	1000	-	-	45	6319 Z	4000	2500	2000	-	-	45
Support type	Bearing type (pulley side)	Rotation speed (RPM)					Grease quantity (grams)	Bearing type (side opposite pulley)	Rotation speed (RPM)					Grease quantity (grams)
		750	1060	1500	2120	3000			750	1060	1500	2120	3000	
		Relubrication intervals in hours							Relubrication intervals in hours					
SN 507 B-BL	22207 EK	4000	2500	1600	1000	670	6	22207 EK	4000	2500	1600	1000	670	6
SN 508 B-BL	22208 EK	3750	2360	1500	950	600	7	22208 EK	3750	2360	1500	950	600	7
SN 509 B-BL	22209 EK	3550	2250	1400	900	560	9	22209 EK	3550	2250	1400	900	560	9
SN 509 C-CR-CS	22209 EK	3550	2250	1400	900	560	9	2209 EK	7100	4500	2800	1800	1120	9
SN 510 B-BL	22210 EK	3350	2120	1320	850	530	11	22210 EK	3350	2120	1320	850	530	11
SN 510 C-CR-CS	22210 EK	3350	2120	1320	850	530	11	2210 EK	6700	4250	2650	1700	1060	11
SN 511 C-CR-CS	22211 EK	3150	2000	1250	800	500	13	2211 EK	6300	4000	2500	1600	1000	13
SN 512 B-BL	22212 EK	3000	1900	1180	750	475	18	22212 EK	3000	1900	1180	750	475	18
SN 512 C-CR-CS	22212 EK	3000	1900	1180	750	475	18	2212 EK	6000	3750	2360	1500	950	18
SN 513 B-BL	22213 EK	2800	1800	1120	710	450	22	22213 EK	2800	1800	1120	710	450	22
SN 513 C-CR-CS	22213 EK	2800	1800	1120	710	450	22	2213 EK	5600	3550	2210	1400	900	22
SN 516 B-BL	22216 EK	2500	1600	1000	630	-	28	22216 EK	2500	1600	1000	630	-	28
SN 516 C-CR-CS	22216 EK	2500	1600	1000	630	-	28	2216 EK	5000	3150	2000	1250	-	28
SN 517 C-CR-CS	22217 EK	2360	1500	950	600	-	32	2217 EK	4750	3000	1900	1180	-	32
SN 518 B-BL	22218 EK	2250	1400	900	560	-	34	22218 EK	2250	1400	900	560	-	34
SN 518 C-CL-CR-CRL-CS-CSL	22218 EK	2250	1400	900	560	-	34	2218 EK	4500	2800	1800	1120	-	34
SN 520 B-BL-C	22220 EK	2000	1250	800	-	-	40	22220 EK	2000	1250	800	-	-	40
SN 522 B-BL-C	22222 EK	1800	1120	710	-	-	50	22222 EK	1800	1120	710	-	-	50
SN 524 B-BL-C	22224 EK	1600	1000	630	-	-	60	22224 EK	1600	1000	630	-	-	60
SN 526 C	22226 EK	1500	950	600	-	-	70	22226 EK	1500	950	600	-	-	70
SN 528 B-BL-C	22228 CCK/W33	1320	850	-	-	-	80	22228 CCK/W33	1320	850	-	-	-	80
SN 530 C	22230 CCK/W33	1180	750	-	-	-	90	22230 CCK/W33	1180	750	-	-	-	90

NOTES:
 Relubrication intervals calculated on basis of diagram taken from maintenance manual for SKF bearings, with temperature on the outer ring of 70°C.
 Quantity of grease in grams calculated according to SKF standards.

Chart 8-2 Relubrication intervals and quantity of grease according to fan rotation speed

8.2 Checking spherical roller bearings

Before fitting the bearing, the internal radial clearance above the roller located in the highest position must be checked with a feeler gauge (see Fig. 8-1 Checking radial clearance on bearings).

During fitting, check the reduction of internal clearance beneath the lowest roller several times.

Correct fitting is obtained with a reduction of internal clearance and minimum residual clearance corresponding to the indications given in Chart 8-3.

Roller bearing	Radial clearance reduction (mm)	Minimum residual clearance after fitting (mm)	
		Normal clearance	C3 clearance
22209 EK	from 0.025 to 0.030	0.020	0.030
22210 EK	from 0.025 to 0.030	0.020	0.030
22212 EK	from 0.030 to 0.040	0.025	0.035
22214 EK	from 0.040 to 0.050	0.025	0.040
22215 EK	from 0.040 to 0.050	0.025	0.040
22216 EK	from 0.040 to 0.050	0.025	0.040
22218 EK	from 0.045 to 0.060	0.035	0.050
22220 EK	from 0.045 to 0.060	0.035	0.050
22222 EK	from 0.050 to 0.070	0.050	0.065
22224 EK	from 0.050 to 0.070	0.050	0.065
22228 CCK/W33	from 0.065 to 0.090	0.055	0.080
22230 CCK/W33	from 0.075 to 0.100	0.055	0.090

Chart 8-3 Checking radial clearance on bearings

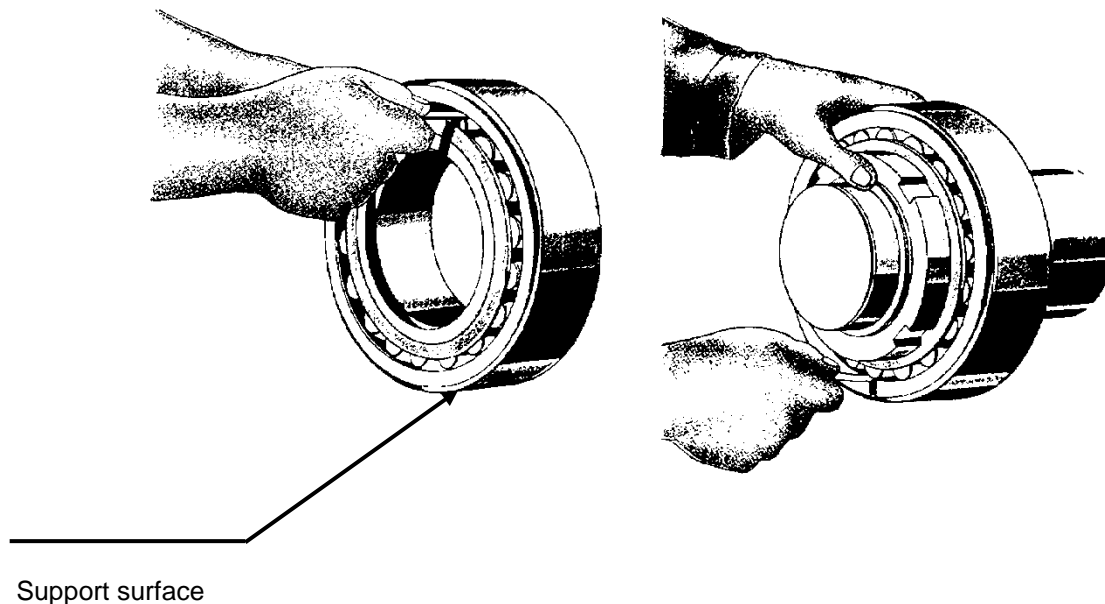


Fig. 8-1 Checking radial clearance on bearings

8.3 Checking self-aligning ball bearings

Correct fitting is obtained with a tightening angle, axial movement and minimum residual clearance corresponding to the indications of Chart 8-4.

Self-aligning ball bearing	Tightening angle (degrees)*	Axial movement s (mm)	Minimum residual clearance after fitting (mm)	
			Normal clearance	C3 clearance
2207 EK	70	0.30	0.010	0.020
2208 EK	70	0.30	0.010	0.020
2209 EK	80	0.35	0.015	0.025
2210 EK	80	0.35	0.015	0.025
2211 EK	75	0.40	0.015	0.030
2212 EK	75	0.40	0.015	0.030
2213 EK	80	0.40	0.015	0.030
2215 EK	85	0.45	0.020	0.040
2216 EK	85	0.45	0.020	0.040
2217 K	110	0.60	0.020	0.040
2218 K	110	0.60	0.020	0.040

- values higher by an average of 15–20° for C3 bearings

Chart 8-4 Tightening angle, axial movement and minimum residual clearance on ball bearings

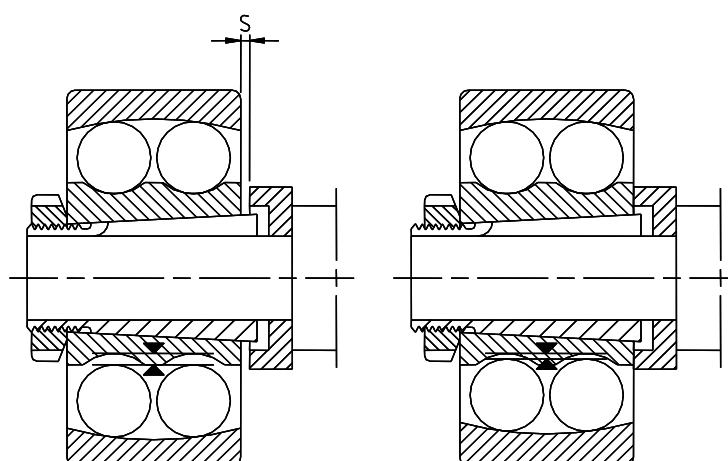


Fig. 8-2 Axial movements

8.4 Adjusting drive belt tension and cleaning belts

A simplified method for setting the correct tension of V-belts is as follows: Chart 8-5 can be used to obtain the value P of the load for each belt for the profile type and the diameter of the smaller pulley. The value L can also be obtained from the same chart.

Use this formula:

$$L_e = \frac{LxI}{100}$$

to calculate the value L_e , where:

L_e = deflection [in mm] of the section at the centre point of distance I between pulley centres

L = deflection for distance between centres of 100 mm

I = distance between centres [in mm]

Applying load P perpendicularly to the section (Fig. 8-3 and Fig. 8-4) the transmission must be tightened until the calculated deflection L_e is reached.

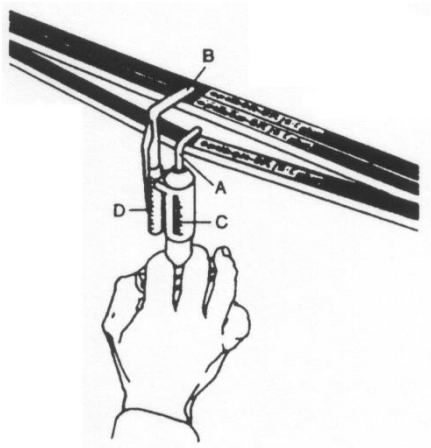


Fig. 8-3 Checking drive belt tension

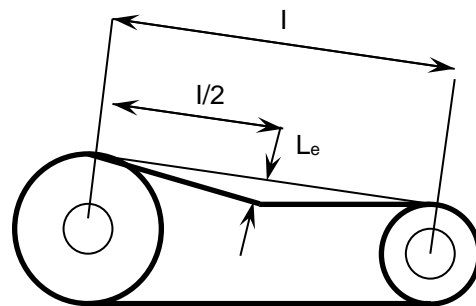



Fig. 8-4 Setting drive belt tension

Profile	Load on belt P [N]	Diameter of smaller pulley d [mm]	Deflection for distance between centres of 100 mm L_e
SPZ	25	from 63 to 71	2.45
		from 75 to 90	2.20
		from 95 to 125	2.05
		over 125	1.90
SPA	50	from 100 to 140	2.75
		from 150 to 200	2.55
		over 200	2.45
SPB	75	from 160 to 224	2.55
		from 236 to 355	2.22
		over 355	2.10
SPC	125	from 224 to 250	2.55
		from 265 to 355	2.20
		from 400 to 560	2.00
		over 560	1.90

Chart 8-5 Setting drive belt tension: test load and deflection


Check drive belt tension at least after about the first 8 hours of operation, and then follow the indications given for programmed maintenance (see paragraph 12.3).

Completely replace belts when worn to a degree that affects satisfactory operation of the transmission due to an insufficient value of pre-tension or if slipping is more than 4-5%. Belt wear depends on various factors, including environmental factors, the number of operation hours, and the number and type of start-ups.

	<p><i>The manufacturers of standard V-belts recommend that an ambient temperature of 80°C should not be exceeded. For higher temperatures, special belts are necessary.</i></p>
---	---

Dirty belts must not be cleaned with solvents like petrol, benzene, turpentine, etc, or with abrasive or sharp instruments.

It is advisable to use a solution of alcohol and glycerine in a proportion of 1:10. The transmissions installed on **FVI** fans have two or more drive belts.

	<p><i>In the case of breakage of one or more belts, it is advisable to replace the entire set.</i></p>
---	--

8.5 Flexible couplings

According to fan operating conditions, periodic checks should be made on axial play S , angular alignment $A_{max}-A_{min}$ and parallel alignment R (Fig. 8-5, Fig. 8-6, Fig. 8-7). Check the condition of hubs, and lubricate every 3000 hours of operation using the lubricants and quantities recommended (see Chart 8-6).

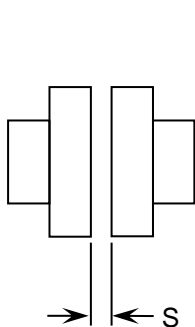


Fig. 8-5 Axial play

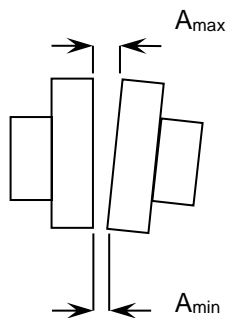


Fig. 8-6 Angular misalignment

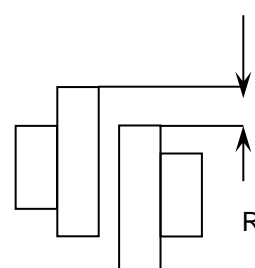


Fig. 8-7 Parallel misalignment

Type	S min [mm]	A _{max} -A _{min} on installation max. [mm]	A _{max} -A _{min} in operation max. [mm]	R max [mm]	Max speed [rpm]	Lubricant [kg]	Recommended lubricant
BT4	2	0.15	0.15	0.15	5000	-	No lubrication required
BT6	2	0.20	0.20	0.20	5000	-	
BT10	2	0.20	0.20	0.20	5000	-	
BT15	2	0.20	0.20	0.20	5000	-	
BT22	2	0.20	0.20	0.20	5000	-	
BT30	2	0.25	0.25	0.25	5000	-	
BT40	2	0.25	0.25	0.25	5000	-	
BT55	2	0.30	0.30	0.30	4900	-	
BT85	2	0.30	0.30	0.30	4300	-	
BT135	2	0.35	0.35	0.35	3700	-	
BT200	2	0.40	0.40	0.40	3400	-	
BT300	3	0.45	0.45	0.45	3000	-	
1020/2020	5.33	0.08	0.25	0.30	4500	0.027	Agip FI FIN 360 Amoco Amolith grease # 2 Chevron USA Chevron Dura-Lith EP2 Gulf Gulf crown grease # 2 Esso Italia Shield 2500 Mobil Mobilux EP 11 Shell Italia Cardium Compound Texaco Starplex HD 2 Valvoline Val-Lith EP
1030/2030	5.03	0.08	0.30	0.30	4500	0.04	
1040/2040	5.36	0.08	0.33	0.30	4500	0.054	
1050/2050	5.38	0.10	0.41	0.41	4500	0.073	
1060/2060	6.55	0.13	0.46	0.41	4350	0.090	
1070/2070	6.58	0.13	0.51	0.41	4125	0.110	
1080/2080	7.32	0.15	0.61	0.41	3600	0.170	
1090/2090	7.26	0.18	0.71	0.41	3600	0.25	
1100/2100	10.9	0.20	0.84	0.51	2440	0.430	
1110/2110	10.9	0.23	0.91	0.51	2250	0.510	
1120/2120	14.2	0.25	1.02	0.56	2025	0.740	
1130/2130	14	0.30	1.19	0.56	1800	0.910	
1140/2140	15.5	0.33	1.35	0.56	1650	1.140	

* The data indicated in charts contained in this manual are taken directly from the technical catalogues of the respective manufacturers.

Chart 8-6 Technical characteristics of flexible couplings

8.6 Filters and pressure gauges

If the fan is fitted with filters for the intake fluid, these must be periodically cleaned so as to prevent increases of load loss at the intake, which would reduce fan performance.

Checks and any necessary cleaning operations must be carried out at predetermined intervals. It is however advisable to use a differential pressure gauge to monitor the pressure gap caused by the filter. This gap must be no more than 400 Pa.



CAUTION:

Do not exceed the pressure value of 400 Pa, to avoid causing possible damage to the filter and the consequent sucking in of filter materials by the fan.

8.7 Flexible anti-vibration joints between the fan and ducting

Flexible joints located between the fan and exit and/or intake ducting must be checked visually to ensure that they are undamaged and that no flexible components have become detached. If these joints must be dismantled for maintenance of the system and/or the fan, they must be reassembled taking the precautions indicated for the first assembly/installation (see paragraph 5.5).

8.8 Checking and cleaning parts in contact with fluids

Periodic impeller cleaning makes it possible to avoid vibrations caused by any dust deposits that accumulate during fan operation.



If the fan is to be used to move fluids that are even slightly dusty, containing abrasive dust, or for pneumatic transport, the impeller must be checked periodically for cleanness and/or wear.

Deposits of material or wear on some impeller parts can produce abnormal fan vibrations.

If there are parts that are excessively worn, it is essential to replace the impeller (for this operation contact the **FVI** Technical Service).



For all information and for any modifications to be made on our products, please contact the **FVI** technical office in advance, specifying the machine type and serial number given on the fan identification plate.

FVI fans can be fitted with a hole and plug for the discharge of any condensation that may form inside the casing. The plug must be opened with the machine at a standstill.



CAUTION:

Opening of the discharge plug may cause the escape of liquid and/or gaseous fluids that may strike the operator, with the consequent risk of injuries to the eyes or other sensitive body parts.

In addition to these risks, on fans operating with fluids at high temperatures, the escape of fluid from the discharge plug may also cause burns or scalding to the skin.



Before starting the fan, always check that the condensation discharge plug is correctly inserted and closed.

9 TECHNICAL CHARTS

9.1 ST supports versions A – AL – B - BL

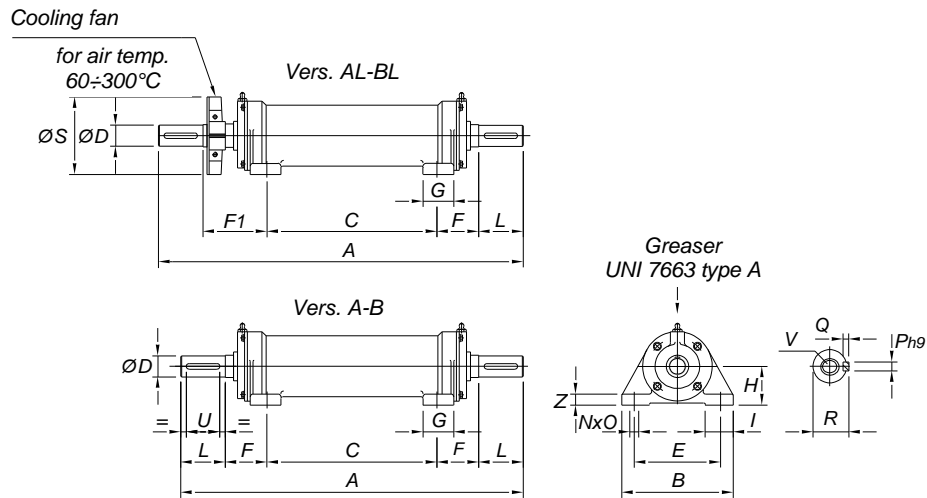


Fig. 9-1 ST supports versions A – AL – B - BL

SUPPORT	DIMENSIONS in mm																	WEIGHT	
	TYPE	A	B	C	D J6	E	F	F1	G	H	I	L	NxO	PxQ	R	S	U		V
ST 47 A ST 47 AL	342 369	135	161	19	100	50.5	77.5	40	40	37.5	40	10x15	6x6	21.5	112	30	M6	16	5 5.05
ST 62 A ST 62 AL	422 454	160	210	24	125	56	88	45	55	40	50	13x18	8x7	27	112	40	M8	18	9.6 9.7
ST 80 A ST 80 AL	575 615	200	308	28	155	73.5	113.5	55	70	50	60	15x20	8x7	31	140	50	M10	21	18 18.3
ST 90 A-B ST 90 AL-BL	615 655	200	308	38	155	73.5	113.5	55	70	50	80	15x20	10x8	41	140	60	M12	21	20 20.4
ST 100 A-B ST 100 AL-BL	753 793	230	378	42	175	77.5	117.5	65	80	60	110	18x25	12x8	45	160	80	M16	24	33 33.5
ST 110 A-B ST 110 AL-BL	753 793	230	378	48	175	77.5	117.5	65	80	60	110	18x25	14x9	51.5	160	80	M16	24	34 34.6
ST 120 A-B ST 120 AL-BL	823 883	260	423	48	200	90	150	80	95	65	110	20x30	14x9	51.5	200	90	M16	26	53 54
ST 130 A-B ST 130 AL-BL	823 883	260	423	55	200	90	150	80	95	65	110	20x30	16x10	59	200	90	M20	26	54 55.3
ST 150 A-B ST 150 AL-BL	974 1034	290	470	65	210	112	172	90	105	80	140	22x35	18x11	69	250	120	M20	27	100 101.8
ST 180 A-B ST 180 AL-BL	1095 1165	340	520	80	260	117.5	187.5	90	125	100	170	25x35	22x14	85	315	140	M20	32	150 153
ST 200 A-B ST 200 AL-BL	1164 1234	370	564	90	290	130	200	100	140	105	170	25x35	25x14	95	315	140	M20	35	260 264

* CONSTRUCTION VERSIONS

Version A: short shaft, ball bearing. -- Version AL: long shaft, ball bearing.

Version B: short shaft, ball bearing on impeller side, roller bearing on transmission side.

Version BL: long shaft, ball bearing on impeller side, roller bearing on transmission side.

Chart 9-1 ST supports versions A – AL – B – BL

9.2 SN supports versions A – AL - B - BL

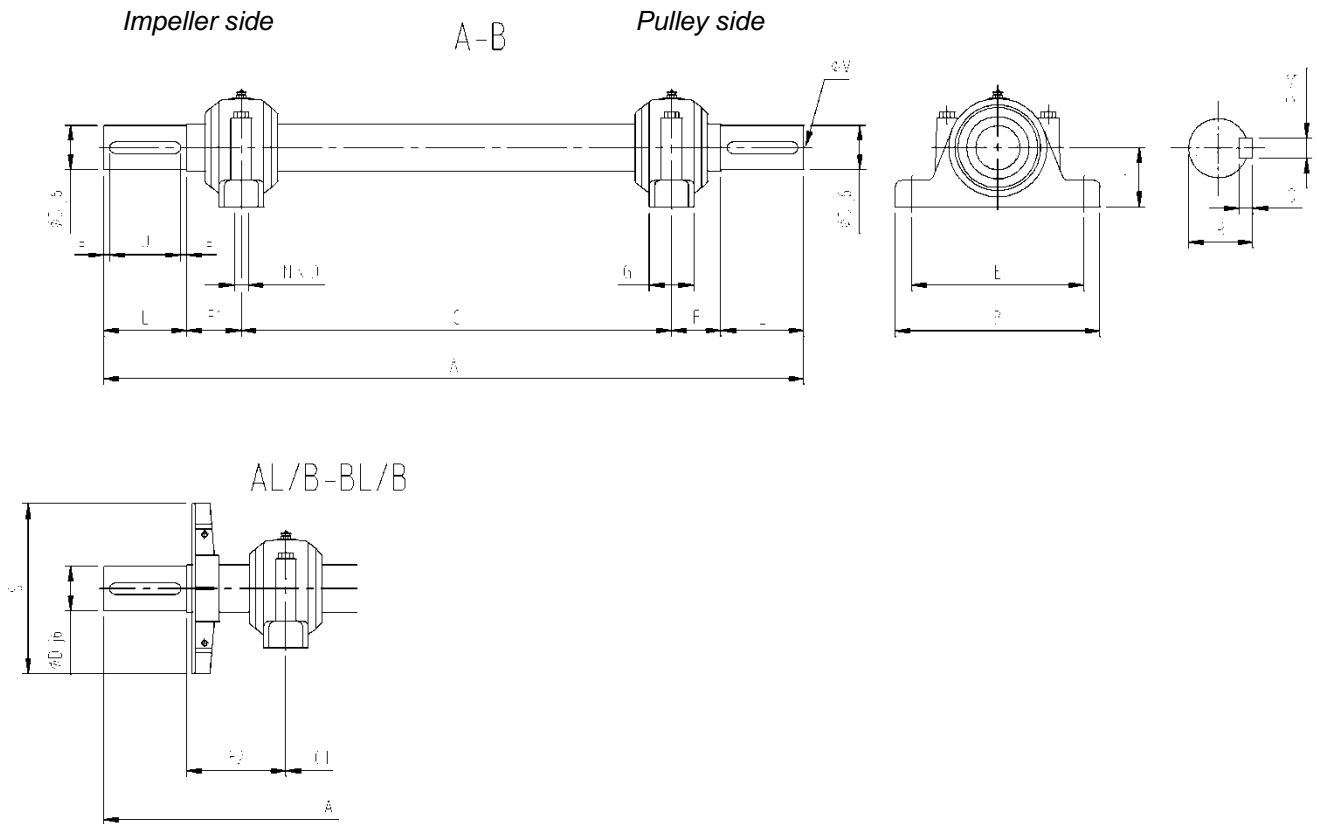


Fig. 9-2 SN supports versions A – AL – B - BL

TYPE	DIMENSIONS IN mm																	WEIGHT Kg	
	A	B	C	C1	D j6	E	F	F1	F2	G	H	L	NxO	PxQ	R	S	U		V
SN 507	422	185	211	171	24	150	53	58	98	52	50	50	15x20	8x7	27	140	40	M8	8
SN 508	575	205	344	304	28	170	53	58	98	60	60	60	15x20	8x7	31	140	50	M10	12
SN 509	615	205	335	295	38	170	57	63	103	60	60	80	15x20	10x8	41	160	60	M12	16
SN 510	753	205	413	373	42	170	57	63	103	60	60	110	15x20	12x8	45	160	90	M16	20
SN 512	865	255	510	450	48	210	63	72	132	70	70	110	18x24	14x9	51.5	200	90	M16	30
SN 513	895	275	535	475	55	230	65	75	135	80	80	110	18x24	16x10	59	200	90	M20	35
SN 516	995	315	560	500	65	260	75	80	140	90	95	140	22x28	18x11	69	250	120	M20	56
SN 518	1180	345	725	650	75	290	83	92	167	100	100	140	22x28	20x12	79.5	315	120	M20	81
SN 520	1285	380	755	680	80	320	90	100	175	110	112	170	26x32	22x14	85	315	140	M20	112
SN 522	1460	410	900	825	90	350	108	112	187	120	125	170	26x32	25x14	95	400	140	M24	150
SN 524	1540	410	900	825	100	350	108	112	187	120	140	210	26x32	28x16	106	400	180	M24	200
SN 528	1750	500	1090	1015	110	420	118	122	197	150	150	210	35x42	28x16	116	400	180	M24	280

Chart 9-2 SN supports versions A – AL – B – BL

9.3 Standard supports and bearings installed on fans with transmission

SUPPORT	Bearing + bush	FA R1 K R1	FC P1 FC N1	KA P1	FE P1 FE N1	KB P1	FG P1 FG N1 VCM N1	FI N1
ST 47 A 19	6204 - Z	351 501						
ST 62 A 24	6305 - Z	631		401 451	401 451		351	
ST 80 A 28	6307 - Z	711 801	501 561	501 561	501 561	401	401	401
ST 90 A 38	6308 - Z	901	631	631	631	451 501	451 501	451 501
ST 100 A 42	6309 - Z		711 801	711 801	711 801	561	561	561
ST 110 B 48	NU 310 ECP 6310 - Z		901	901	901	631	631	631
ST 120 B 48	NU 311 ECP 6311 - Z		1001	1001	1001	711	711	711
ST 130 B 55	NU 312 ECP 6312 - Z		1121		1121	801	801	801
ST 150 B 65	NU 314 ECM 6314 - Z					901	901	901
ST 180 B 80	NU 317 ECM 6317 - Z					1001	1001 1121	1001 1121
ST 200 B 90	NU 319 ECM 6319 - Z						1251	1251
SN 520 B 80	H 320 22220 EK						1401	1401
SN 522 B 90	H 322 22222 EK						1601	1601
SN 524 B 100	H 3124 22224 EK						1801 2001	1801 2001

Chart 9-3 Standard supports and bearings installed on fans with transmission



SUPPORT	Bearing + bush	ART N1 KC R1*	FP N1	MEC N1 FQ N1 KM R1*	FR N1	FS P1	PFB N13 PFM N13
ST 47 AL 19	6204 - Z			251	251	201 221 251	
ST 62 AL 24	6305 - Z			281 311	281 311	281 311	
ST 80 AL 28	6307 - Z		351	351	351	351	351
ST 90 AL 38	6308 - Z	401 451	401 451	401 451	401 451	401 451	401 451
ST 100 AL 42	6309 - Z	501	501	501	501	501	501
AL ST 110 ---- 48 BL	NU 310 ECP 6310 - Z	AL 561 AL 631	AL 561 BL 631	AL 561 AL 631	AL 561 AL 631	AL 561 AL 631	AL 561 AL 631
ST 120 BL 48	NU 311 ECP 6311 - Z	711	711	711	711	711	
ST 513 BS 55	H 313 22213 EK						711
ST 130 BL 55	NU 312 ECP 6312 - Z	801 901	801	801 901	801 901	801 901	801
ST 150 B 65	NU 314 ECP 6314 - Z		901				
ST 516 BS 65	H 316 22216 EK						901
SN 516 BL 65	H 316 22216 EK	1001		1001	1001	1001	1001
SN 518 BL 75	H 318 22218 EK	1121 1251	1001	1121 1251	1121 1251		
SN 518 BL/S 75	H 318 22218 EK						PFB 1121
SN 520 B 80	H 320 22220 EK	1401	1121 1251	1401	1401		PFM 1121 1251
SN 522 B 90	H 322 22222 EK	1601	1401	1601	1601		
SN 524 B 100	H 3124 22224 EK	1801 2001	1601 1801	1801 2001	1801 2001		
SN 528 B 110	H 3128 22228 CCK/W33		2001				

* KC-KM only up to size 1001

Chart 9-4 Standard supports and bearings installed on fans with transmission

SUPPORT	Bearing+ bush	DFR N	DFM N
28 SN 509 C 42 -- 38	H 309 2209EK 22209EK	1 401 -- 2-3	*
32 SN 510 C 48 -- 42	H 310 2210EK 22210EK	1 451 -- 2-3	*
38 SN 511 C 55 -- 48	H 311 2211EK 22211EK	1 501 -- 2-3	*
38 SN 512 C 60 -- 48	H 312 2212EK 22212EK	1 561 -- 2-3	561
42 SN 513 C 65 -- 55	H 313 2213EK 22213EK	1 631 -- 2-3	631
48 SN 516 C 75 -- 60	H 316 2216EK 22216EK	1 711 -- 2-3	711
55 SN 517 C 80 -- 65	H 317 2217K 22217EK	1 801 -- 2-3	801
60 SN 518 C 90 -- 75	H 318 2218K 22218EK	1 901 -- 2-3	901
65 SN 518 CL 90 -- 75	H 318 2218K 22218EK	1 1001 -- 2-3	*
75 SN 520 C 100 -- 80	H 320 22220EK	1 1121 -- 2-3	1001
80 SN 522 C 110 -- 90	H 322 22222EK	1 1251 -- 2-3	1121
90 SN 524 C 120 -- 100	H 3124 22224EK	1 1401 -- 2-3	1251
100 SN 526 C 130 -- 110	H 3126 22226EK	1 1601 -- 2-3	*
110 SN 528 C 140 -- 120	H 3128 22228CCK/W33	1 1801 -- 2-3	*
120 SN 530 C 160 -- 130	H 3130 22230CCK/W33	1 2001 -- 2-3	*

Chart 9-5 Standard supports and bearings installed on fans with transmission

10 DISMANTLING AND REASSEMBLING ESSENTIAL COMPONENTS



CAUTION:

All dismantling and reassembly operations indicated below must be carried out only by qualified and authorized personnel, equipped with the necessary PPE.



CAUTION:

All dismantling and reassembly operations described below must be carried out:

- *With the absolute certainty that the fan is at a complete standstill (impeller stationary); disconnect the power supply to the main control panel with the power switch and apply a lock with key to be consigned to the person responsible for maintenance.*
- *After having created a work environment with all necessary equipment and free from all other activities that could dangerously interfere with dismantling and reassembly operations.*
- *After carefully cleaning, degreasing or lubricating, according to use, all components dismantled and reassembled.*

10.1 Replacement of intake on centrifugal fans

10.1.1 Dismantling intake

1.- Screw the lifting lugs onto two of the bolts welded onto the intake for connection to ducting (Photos 1 and 2).



Photo 1



Photo 2

2.- Fix the intake to the lifting equipment using the lifting lugs (Photo 3).



Photo 3

3.- Unscrew all the bolts securing the intake to the casing (Photo 4).

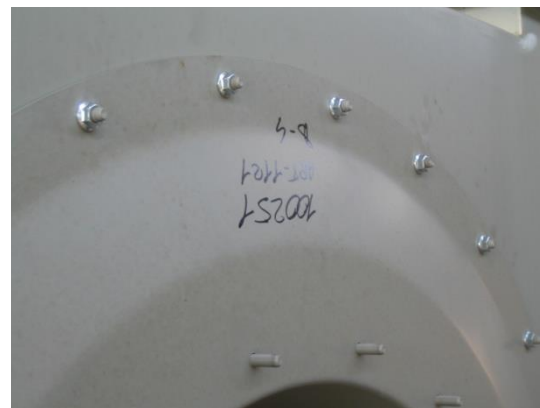


Photo 4

4.- Lift and remove the intake, taking care to avoid damage to the threads of the bolts welded to the casing (Photo 5).



Photo 5

10.1.2 Reassembling intake

1.- Screw the lifting lugs onto two of the bolts welded onto the intake for connection to ducting (Photo 6).



Photo 6

2.- Fit the sealing gasket around the ring of bolts welded to the fan casing (Photo 7).



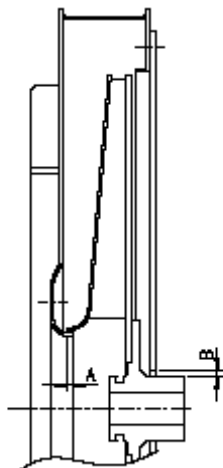
Photo 7

3.- Lift the intake and align the ring of holes with the ring of bolts welded to the fan casing (Photo 8).



Photo 8

4.- Screw on the nuts that fix the intake to the casing, tightening them in diametrically opposite pairs (Photo 4).

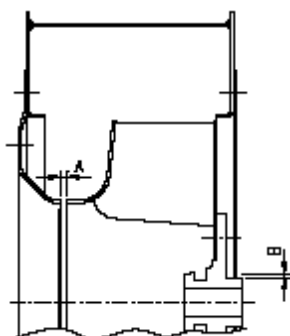


SERIES	High pressure - VCM	
SIZE	A	B
311 ÷ 501	4 ÷ 7	2
561 ÷ 801	5 ÷ 9	2 ÷ 2.5
901 ÷ 1121	7 ÷ 12	2.5

A and B in millimetres

Fig. 10-1 Centring of impeller intake on high-pressure series – VCM

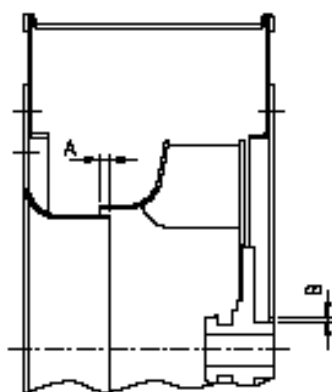
5.- Before definitively tightening the nuts, check that the intake is correctly centred with respect to the impeller, as shown in Fig. 10-1, Fig. 10-2 and Fig. 10-3, making any necessary adjustments to the intake position.



SERIES	MEC - ART	
SIZE	A	B
251 ÷ 901	3 ÷ 4	2 ÷ 2.5
1001 ÷ 2001	5 ÷ 9	2.5

A and B in millimetres

Fig. 10-2 Centring of impeller intake on series MEC – ART



SERIES	FQ-FR-DFR-FS-DFS	
SIZE	A	B
181 ÷ 501	4 ÷ 7	2
561 ÷ 801	5 ÷ 9	2 ÷ 2.5
901 ÷ 1121	6 ÷ 10	2.5
1251 2001	7 ÷ 12	2.5

A and B in millimetres

Fig. 10-3 Centring of impeller intake on series FQ-FR-DFR-FS-DFS

10.2 Casing

All orientable fans have a ring of welded bolts. To remove this, unscrew the nuts fixing it to the motor pedestal disk from the bolts welded to the casing (Photo 9).

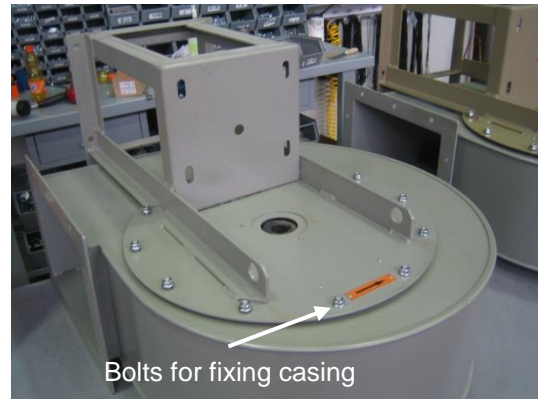


Photo 9

Fans with an integral non-orientable casing cannot be disassembled (Photo 10).



Photo 10

On some construction versions, the casing is divided into two or more parts, joined by bolted flanges (Photo 11).



Photo 11

10.3 Replacement of impeller

This section describes the procedure followed by **FVI** to dismantle and then reassemble centrifugal fan impellers. The description of these operations includes references to tools made by **FVI** (in particular the extractor bush and the impeller lifting tube), used to facilitate operations. Although these tools are useful, they are not indispensable for the operations described. **FVI** is therefore not obliged to supply these tools, because the same functions can be carried out with similar commercially available tools.

CAUTION! The impeller hub may have a circumferential extraction groove (Fig. 10-4) or threaded extraction holes (Fig. 10-5).

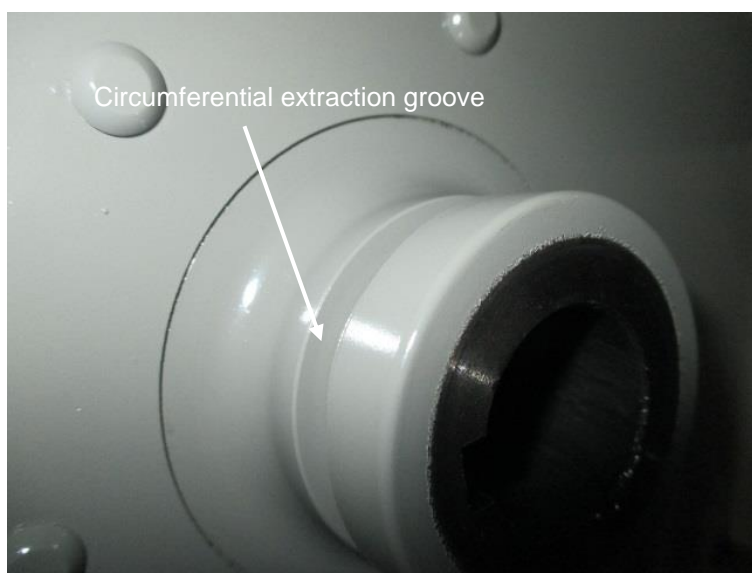


Fig. 10-4 Hub with circumferential extraction groove

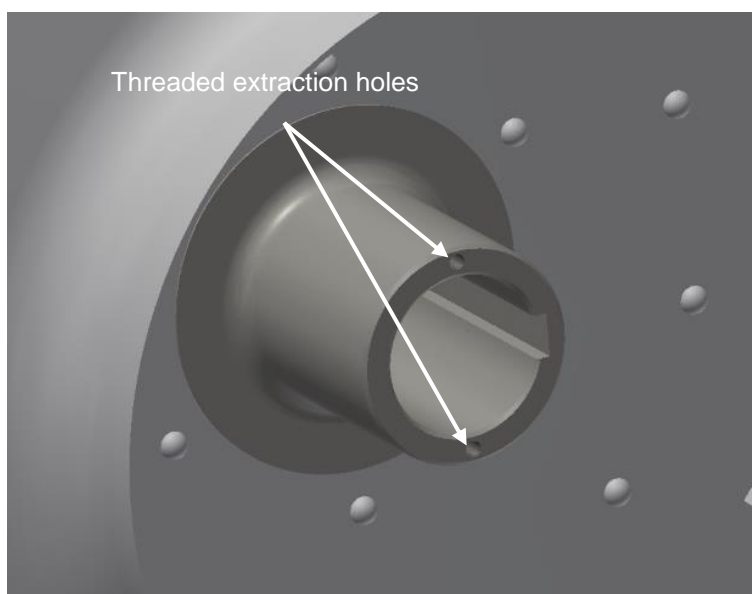


Fig. 10-5 Hub with threaded extraction holes

10.3.1 Dismantling impeller

1.- Unscrew the central impeller fixing bolt and remove the fixing disk (Photo 12).

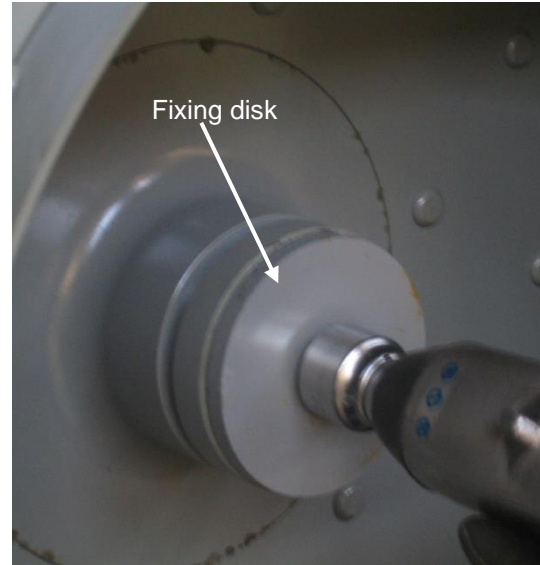


Photo 12

2.- Hub with circumferential extraction groove: screw the extractor bush into the threaded hole in the motor shaft (Photo 13).

Hub with threaded extraction holes: screw a measurement screw of the same size as the impeller fixing bolt into the threaded hole in the motor shaft.



Photo 13

3.- Hub with circumferential extraction groove: rest the tip of the threaded rod of the extractor against the threaded rod of the extractor bush, placing an anti-friction washer between them. Hook the grips of the extractor into the extraction groove on the impeller hub (Photo 14a).

Hub with threaded extraction holes: screw the peripheral bolts into the threaded holes on the hub and rest the tip of threaded rod of the extractor on the head of the bolt screwed into the motor shaft (Photo 14b).



Photo 14a



Photo 14b

4.- Turn the head of the threaded rod of the extractor, preferably using a pneumatic wrench, until the impeller is pulled away from the motor shaft (Photos 15a and 15b). In the case of a hub with an extraction groove, the impeller rests partially on the extractor bush, which is already present. In the case of a hub with threaded holes, remove the extractor and the bolt screwed into the motor shaft, and then insert the extraction bush as shown in Photo 13.



Photo 15a



Photo 15b

5.- After removing the extractor from the impeller and inserting the extraction bush if necessary, fit the impeller lifting tube onto the extractor bush (Photo 16).



Photo 16

	<p>CAUTION:</p> <p><i>The external diameter of the tube must be a few millimetres less than the diameter of the hole in the hub. Its thickness must ensure the fitting of an adequate length of the tube onto the extractor bush and at the same time it must be sufficiently strong to safely support the weight of the impeller.</i></p>
--	---

	<p>CAUTION:</p> <p><i>Secure the free end of the impeller lifting tube at point A.</i></p> <div style="text-align: center;"> </div>
--	--

Fig. 10-6 Securing impeller lifting tube

6.- Keeping end A of the lifting tube secured (see Fig. 10-6) slide the impeller along the tube until it is outside the casing, allowing suitable lifting equipment to be attached (Photo 17).

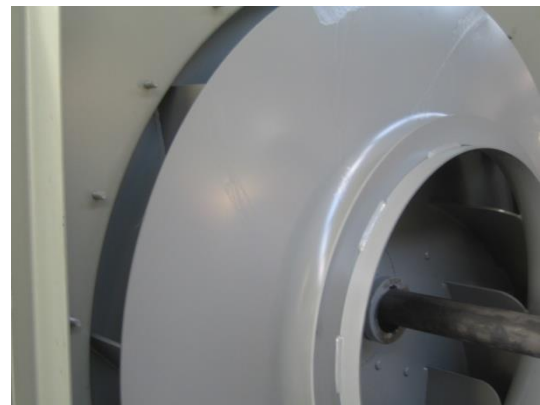


Photo 17

7.- Support the impeller with suitable lifting equipment (Photo 18).

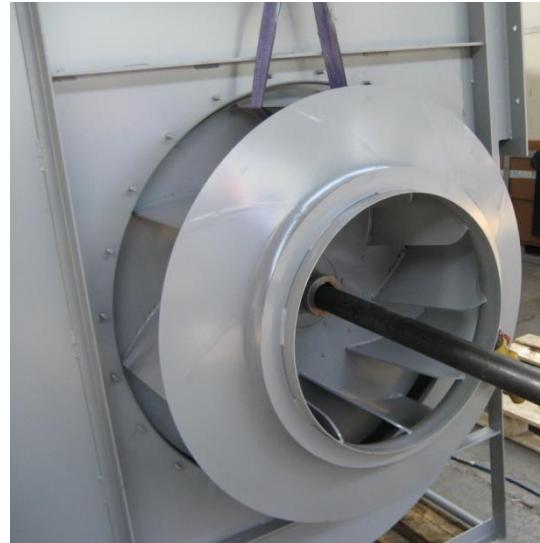


Photo 18

8.- Pull out the lifting tube.

9.- Lift and extract the impeller (Photo 19).



Photo 19

10.- Unscrew and remove the extractor bush.

10.3.2 Reassembling impeller



IMPORTANT:

If necessary, reduce the diameter of the motor shaft until its nominal size is reached with a tolerance of +0/+5 microns. Assembly with excessive play can cause vibrations. Forced assembly creates deformations and vibrations, also making it more difficult to remove the impeller.

1.- Screw the impeller extractor bush onto the motor shaft (Photo 20).



Photo 20

2.- Check that the spline on the motor shaft is correctly inserted.

3.- Lubricate the shaft surface with a thin layer of grease.

4.- Lift the impeller and fit it as far into the casing as the lifting equipment allows (Photo 21).



Photo 21

5.- Fit the lifting tube into the hole in the impeller hub and fit it onto the extractor bush (Photo 22).

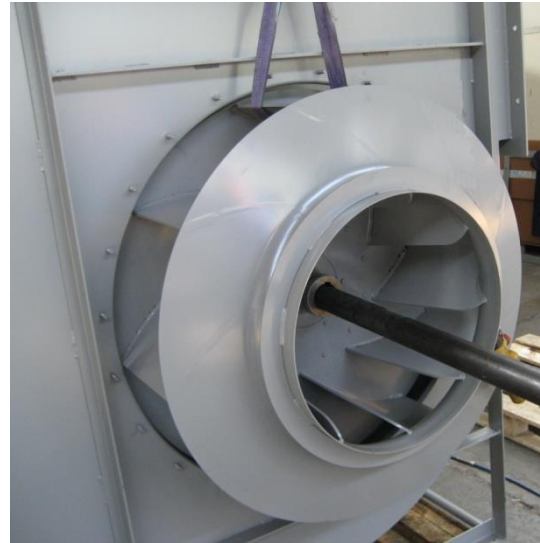


Photo 22

6.- Secure free end A of the lifting tube (see Fig. 10-4).

7.- Detach and remove the lifting equipment, leaving the impeller supported only by the lifting tube.

8.- Push the impeller along the lifting tube as far as possible, until the hub fits onto the motor shaft (Photo 23). Check that the spline on the shaft is aligned with the slot in the impeller hub.



Photo 23

9.- Remove the impeller lifting tube and extractor bush (Photo 24).



Photo 24

10.- Use a threaded rod and a pneumatic wrench to push the impeller fully onto the motor shaft (Photo 25). When the impeller is fully inserted, the hub will touch the stop on the motor shaft.



Photo 25

11.- Remove the threaded bar and disk.

12.- Position the impeller fixing disk and screw in the central impeller fixing bolt until the tightening torque indicated in Chart 12-1 has been reached (Photo 26).

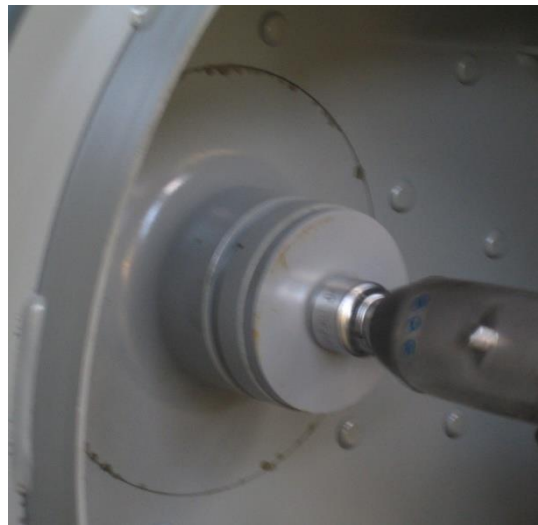


Photo 26

10.4 Replacing drive belts

10.4.1 Assembling and dismantling pulleys

1.- Check that the motor shaft and the transmission shaft are parallel.

2.- Before fitting the bush (Photo 27) into the pulley, carefully clean tapered parts and the bush hole.



Photo 27

3.- Fit the bush into the hole in the pulley, taking care to align the threaded half-holes on the pulley with the unthreaded half-holes on the bush (Photo 27). There may be 2 or 3 of these holes (Fig. 10-7), as can also be seen in Chart 10-1, depending on pulley size.

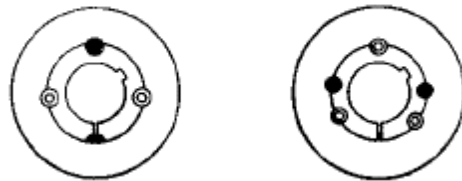


Fig. 10-7 Pulley holes

4.- Screw in the grub screws by hand without fully tightening them (Photo 28).



Photo 28

5.- Check that the shaft surface is totally clean, and insert the fixing spline into its slot (Photo 29).

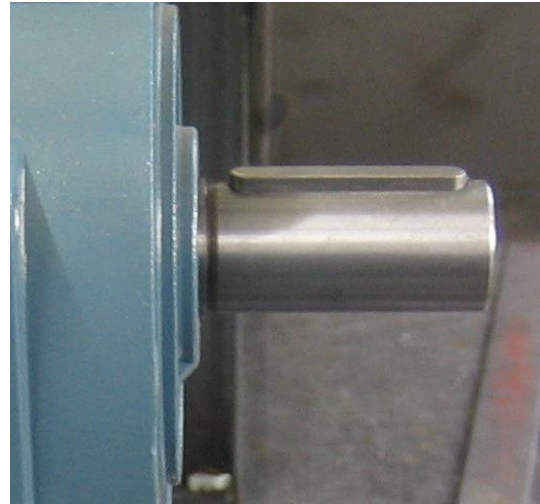


Photo 29

6.- Fit the assembled bush, grub screws and pulley onto the motor shaft with the spline inserted in the corresponding slot in the bush hole (Photo 30).

If necessary, widen the bush hole by inserting a suitable tool into the bush slit (Photo 31).



Photo 30

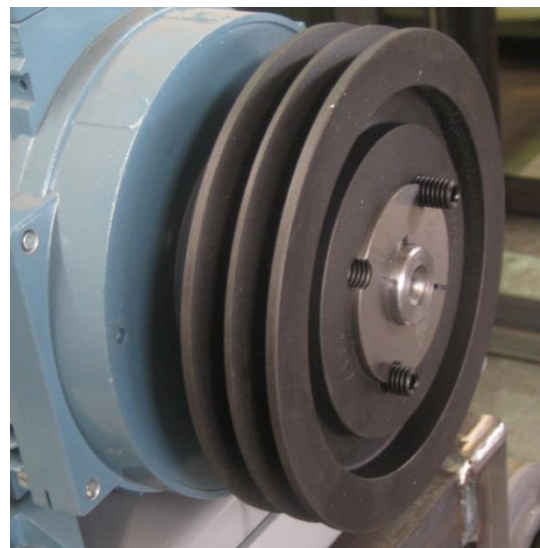


Photo 31

7.- Always check that there is a minimum of clearance between the spline and the corresponding slot (Photo 32).

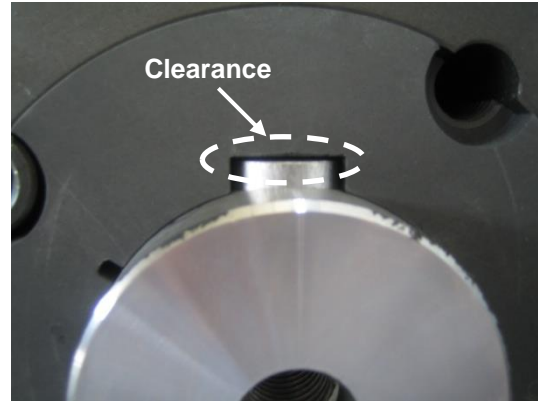


Photo 32

8.- Repeat operations 2 to 7 to fit the pulley onto the transmission shaft.

9.- Use a straight edge of a suitable length to check correct alignment of the pulleys (Photo 33).

Use a rubber hammer to move pulleys axially until the parallel misalignment has been corrected (Photo 34).



Photo 33

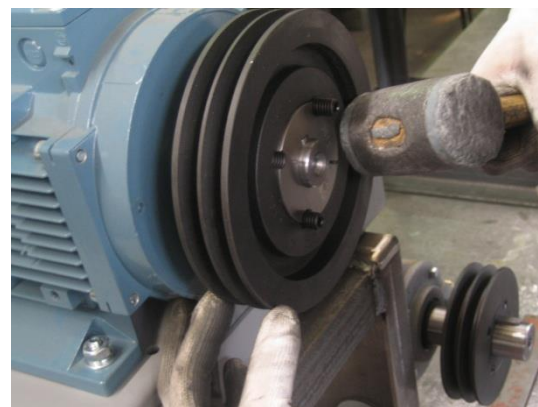


Photo 34

10.- Adjust motor position to correct misalignment (Fig. 10-8 and Fig. 10-9).

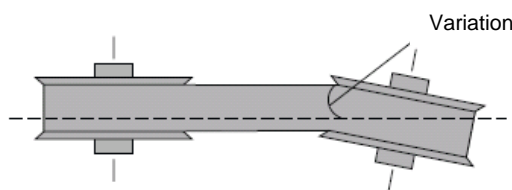


Fig. 10-8 Angular misalignment

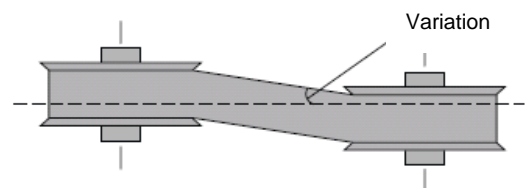


Fig. 10-9 Parallel misalignment

11.- Tighten the pulley grub screws alternately (Photo 35) until the tightening torque indicated in Chart 10-1.

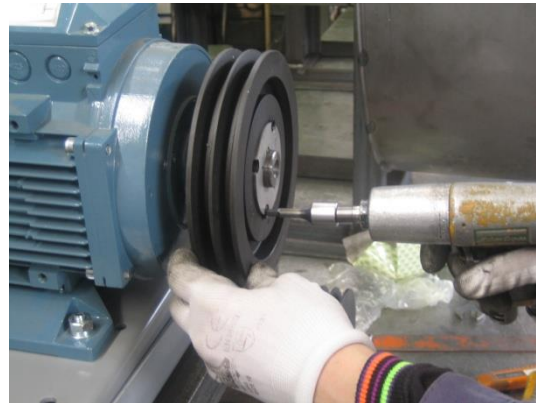




Photo 35

12.- Check correct pulley alignment again.

	<p>CAUTION:</p> <p><i>Incorrect alignment causes excessive wear and greater friction on drive belts, higher power absorption by the transmission, noise and vibrations that reduce the effective lifespan of the transmission.</i></p>
---	---

Generally, the tolerance in pulley alignment in V-belt drive transmissions may not be greater than 0.5 degrees or 5 mm for each 500 mm of distance between centres (Fig. 10-8 and Fig. 10-9).

	<p>CAUTION:</p> <p><i>To remove pulleys, unscrew the grub screws used to fix them and insert one or two of them in the free holes, screwing them in until the bush is detached.</i></p>
---	--

Type	Bush		Grubscrews				
	Length [mm]	Diameter max [mm]	No.	Whitworth	Length [mm]	Socket size	Tightening torques [N.m]
1008 (25.20)	22.3	35	2	1/4	13	3	5.5
1108 (28.20)	22.3	38	2	1/4	13	3	5.5
1210 (30.25)	25.4	47	2	3/8	16	5	20
1215 (30.40)	38.1	47	2	3/8	16	5	20
1310 (35.25)	25.4	52	2	3/8	16	5	20
1610 (40.25)	25.4	57	2	3/8	16	5	20
1615 (40.40)	38.1	57	2	3/8	16	5	20
2012 (50.30)	31.8	70	2	7/16	22	5	20
2517 (65.45)	44.5	85	2	1/2	25	6	50
3020 (75.50)	50.8	108	2	5/8	32	8	90
3030 (75.75)	76.2	108	2	5/8	32	8	90
3535 (90.90)	88.9	127	3	1/2	38	10	115
4040 (100.100)	101.6	146	3	5/8	44	14	170
4545 (115.115)	114.3	162	3	3/4	51	14	195
5050 (125.125)	127	178	3	7/8	57	17	275

Chart 10-1 Tightening torques

10.4.2 Assembling and dismantling drive belts

1.- After checking correct pulley alignment, fit the belts. Tools should not be used to force the belts into place on the pulleys (Photos 36, 37 and 38). If necessary, reduce the distance between pulley centres by moving the motor closer.



Photo 36

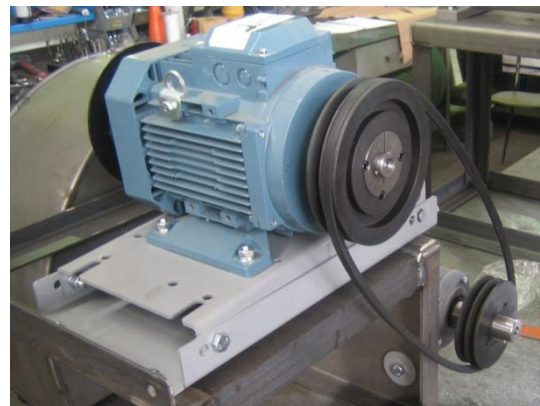


Photo 37

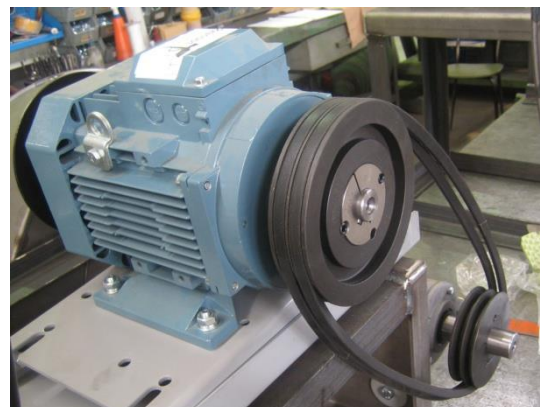


Photo 38

2.- Check belt tension. For this operation, see paragraph 8.4 of this manual.

3.- If the tension of belts is insufficient, the motor must be moved to tension them correctly.

For version 9 fans (motor supported on the side of the motor pedestal), use the stays to move the motor base (Photo 39).



Photo 39

For version 12 fans, (with motor resting on base), slightly slacken the motor fixing bolts on the motor base and adjust the stays on the sides to move the motor. Then tighten the motor fixing bolts again (Photo 40).

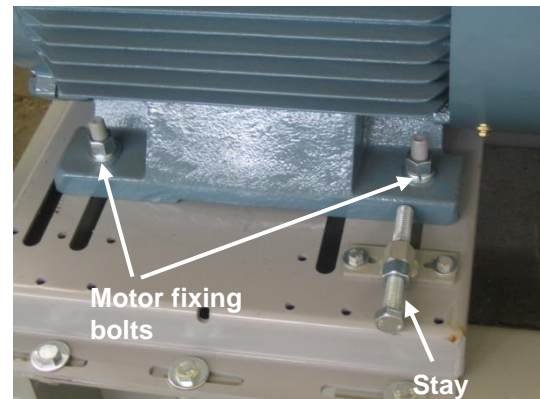


Photo 40

4. Check correct pulley alignment again.

5.- Fit the transmission guard.



CAUTION:

After the first 8 hours of operation, stop the fan and check that pulley assembly screws are still fully tightened.

6.- To remove the drive belts, repeat the previous operations in the reverse order.

10.5 Replacing shaft and bearings on one-piece support

10.5.1 Dismantling shaft on one-piece support



CAUTION:

All the operations described below must be carried out in a perfectly clean environment, also avoiding introducing any source of contamination inside the support.

FVI one-piece supports for fans with transmission (Photo 41) can be of two types, according to the type of bearing fitted on the pulley side or the coupling side (LP transmission side):



Photo 41.- One-piece support

- Type ST...A... support with rigid ball bearing on transmission side (Fig. 10-10).
- Type ST...B... support with rigid roller bearing on transmission side (Fig. 10-11). The side with the roller bearing is punched with "CR" on the shaft.

Both types of support are fitted with a ball bearing on the impeller side (LG).

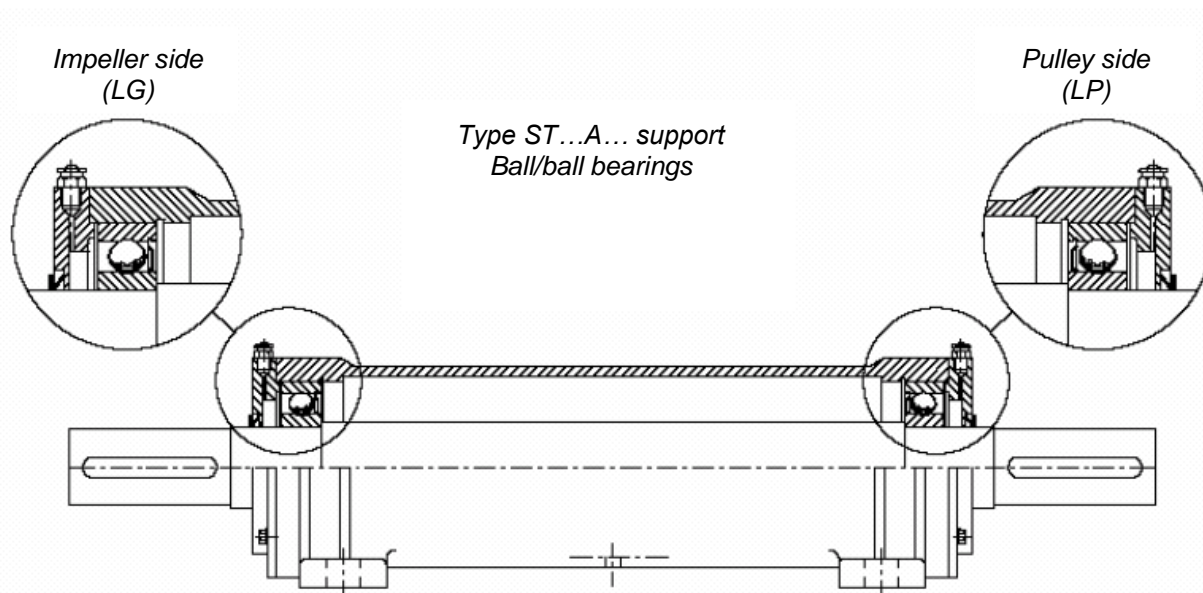


Fig. 10-10 ST...A... one-piece support with radial ball bearings both on impeller side and transmission side

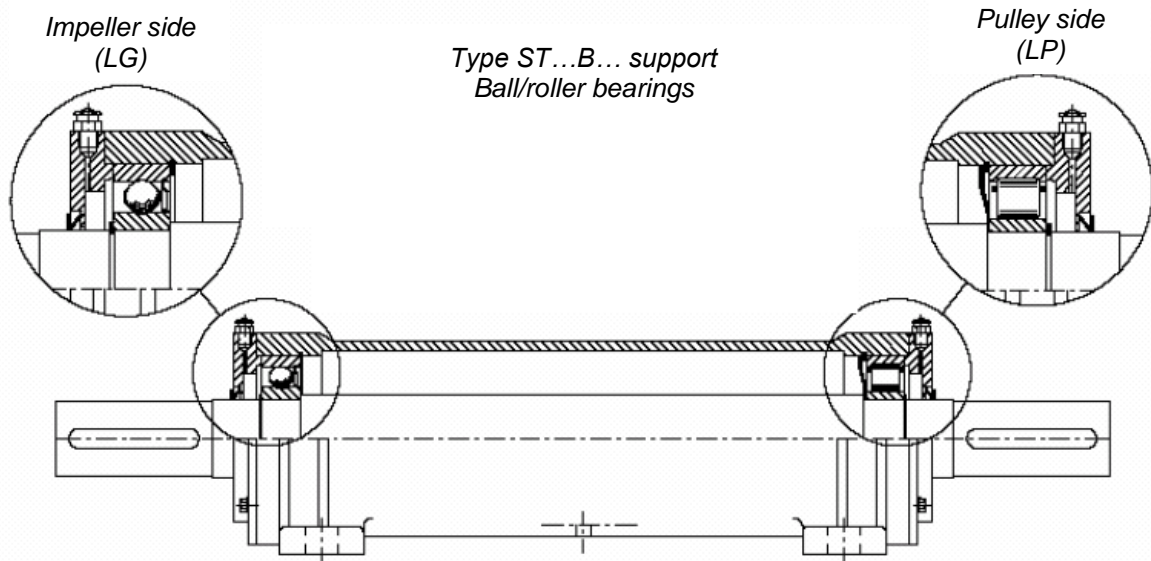


Fig. 10-11 ST...B... one-piece support with radial ball bearings on impeller side and roller bearings on transmission side

On Type ST...B... supports, the shaft must be extracted from the impeller side. On Type ST...A... supports, the shaft can be extracted from both sides. It is however advisable to always extract the shaft from the impeller side, above all when you are not certain of the type of support to be dismantled.

The steps for shaft dismantling are as follows:

- 1.- For supports with a cooling fan installed, the cooling fan must first be dismantled (Fig. 10-12 Fig. 10-12).

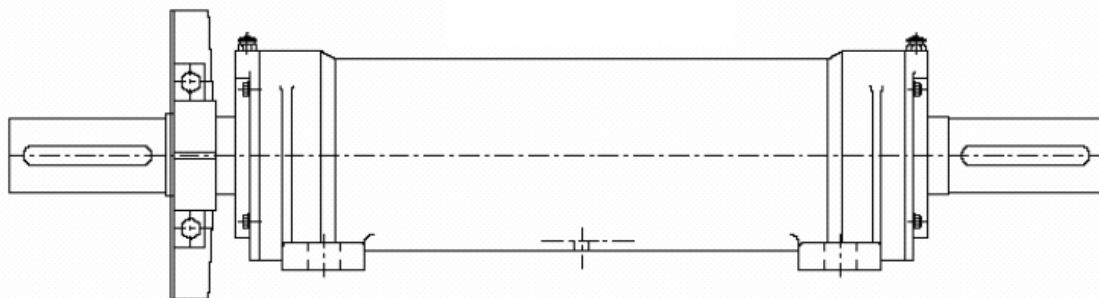


Fig. 10-12 Support with cooling fan

2.- Remove the two VA sealing rings located between the shaft and the two support end covers (Photo 42).



Photo 42

3.- Remove the fixing bolts and the cover on the impeller side (Photo 43).



Photo 43

4.- Extract the shaft.

For Type ST...A... supports, the last operation is to completely remove the shaft. When this is done, the two bearings, both on the impeller side and on the transmission side, are also extracted (Photo 44). To dismantle the radial bearings from the shaft use an extractor.



Photo 44

For Type ST...B... supports, extract the shaft only partially, resting it in an intermediate position (Photo 45).



Photo 45

5.- With the shaft still partially inside the support, remove the spring locking ring located in the support from the impeller side, using suitable pliers (Photo 46).



Photo 46

6.- Completely extract the shaft. When this is done, the ball bearing on the impeller side, the spring locking ring that secures the ball bearing to the shaft, the internal roller bearing ring on the transmission side and the spring locking ring that secures the roller bearing to the shaft (if present) are also extracted (Photo 47).



Photo 47

7.- Remove the bolts and the cover on the pulley side (Photo 48).

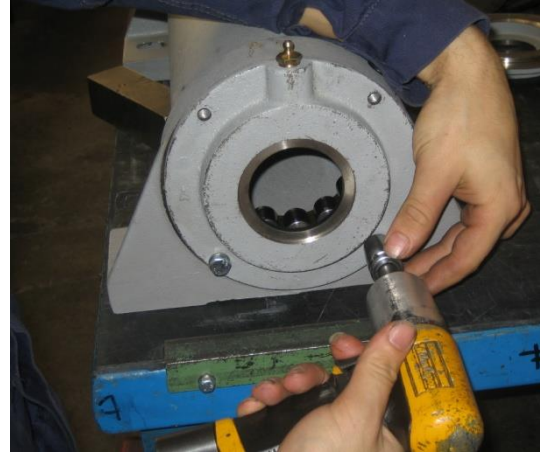


Photo 48

8.- Extract remaining components (casing, rollers and external ring) of the roller bearing (Photo 49).



Photo 49

9.- Remove the spring locking ring located on the transmission side of the support, using suitable pliers (Photo 50).

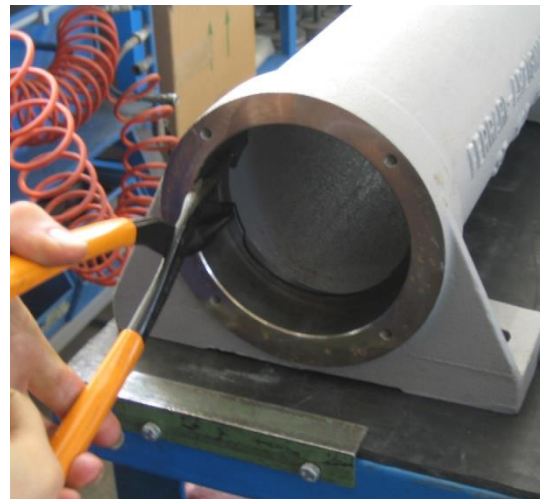


Photo 50

10.5.2 Reassembling shaft on one-piece support

All the operations described below must be carried out in a perfectly clean environment, also avoiding introducing any source of contamination inside the support.

10.5.2.1 Type ST... A... supports

1.- Fit the two ball bearings onto the transmission shaft from both sides (Photo 51). Preheat the internal bearing rings to a temperature of about 70°C before carrying out this operation, or use a press or a hammer.



Photo 51

2.- Fully insert the shaft, complete with the two bearings, into the support (Photo 52).

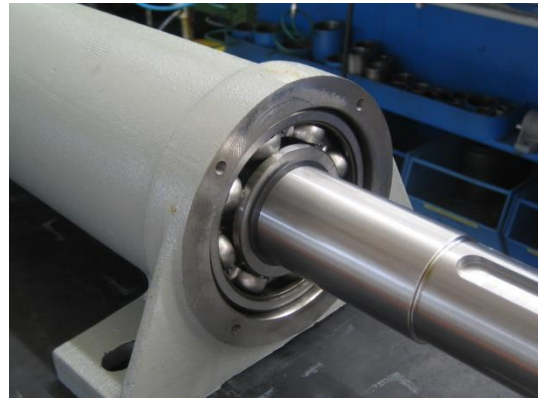


Photo 52

3.- Grease the bearings using the type of grease recommended in Chart 8-1.

4.- Bolt on the covers at both ends of the support (Photo 53).

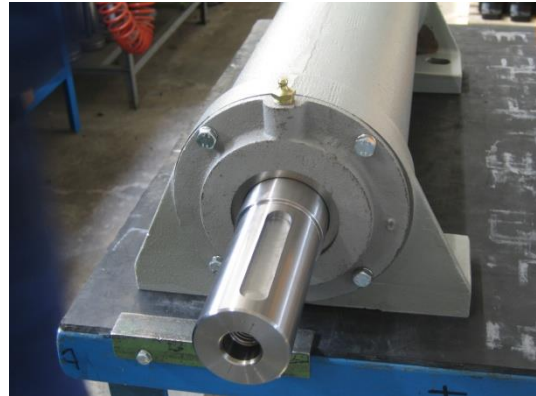


Photo 53

5.- Insert the two VA sealing rings between the shaft and the support end covers (Photo 54).

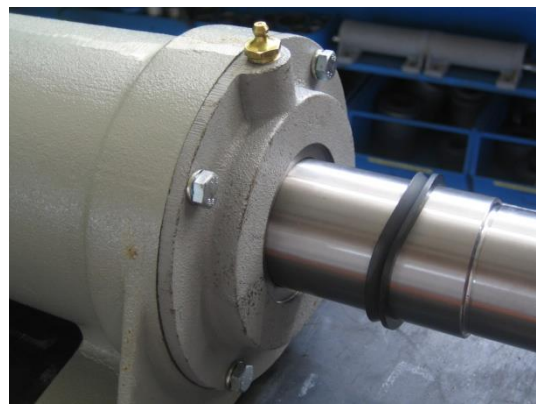


Photo 54

10.5.2.2 Type ST...B... supports

1.- Fit the grease sealing ring up to the stop on the shaft from the transmission side (Photo 55).

Take care to fit the grease sealing ring in the right direction (Fig. 10-9 and Photo 55).



Photo 55

2.- Fit the spring locking ring (to be fixed inside the support) onto the shaft from the impeller side. The ring will be suspended from the shaft, but is not fixed (Photo 56).



Photo 56

3.- Fit the ball bearing onto the shaft from the impeller side, and secure it axially using the spring locking ring (Photo 57).

Preheat the internal bearing ring to a temperature of about 70°C before carrying out this operation, or use a press or a hammer.



Photo 57

4.- Fit the internal ring of the roller bearing onto the shaft from the transmission side, and secure it axially using the spring locking ring (Photo 58). Preheat the internal bearing ring to a temperature of about 70°C before carrying out this operation, or use a press or a hammer.



Photo 58

5.- Fix the spring locking ring into the recess in the support from the transmission side (Photo 59).

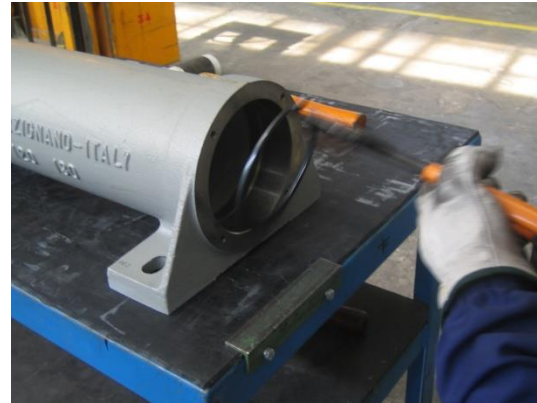


Photo 59

6.- Partially insert the shaft, complete with all components fitted, into the support. The shaft must be fitted from the impeller side, first inserting the end of the shaft with the internal ring of the roller bearing and the grease sealing ring (Photo 60).



Photo 60

7.- Before completely inserting the shaft, rest it in an intermediate position and fix the suspended spring locking ring in the recess on the impeller side of the support (Photo 61).



Photo 61

8.- Fully insert the shaft (Photo 62).

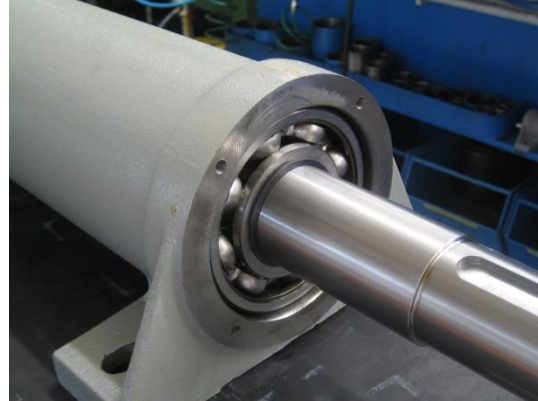


Photo 62

9.- From the transmission side, insert the remaining roller bearing components: casing, rollers and external ring (Photo 63).



Photo 63

10.- Grease the bearings using the type of grease recommended in Chart 8-1 (Photo 64).

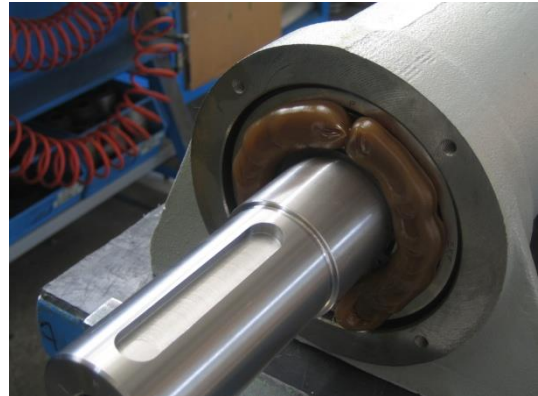


Photo 64

11.- Bolt on the covers at both ends of the support (Photo 65).



Photo 65

12.- Insert the two VA sealing rings between the shaft and the support end covers (Photo 66).

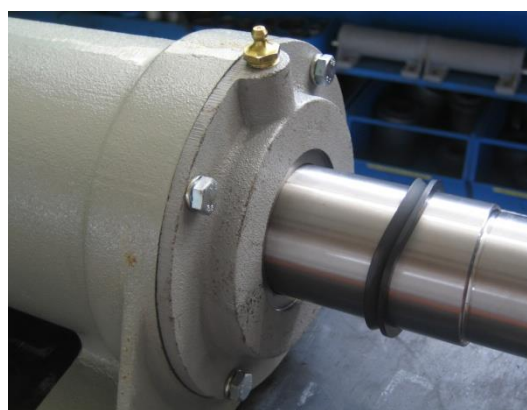


Photo 66

10.6 Replacement of bearings and flexible coupling on version 8 fans



CAUTION:

Before starting replacement operations, procure a complete replacement flexible coupling and two complete sets of bearings (bearing, bush, seals, stop ring, etc.).

The description of replacement operations makes reference to the components indicated in Fig. 10-13 and Photo 67.

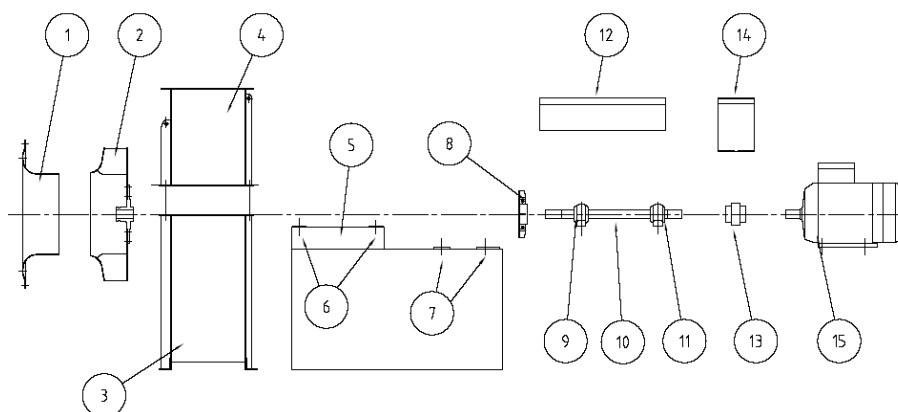


Fig. 10-13 Components of version 8 fans driven by flexible coupling

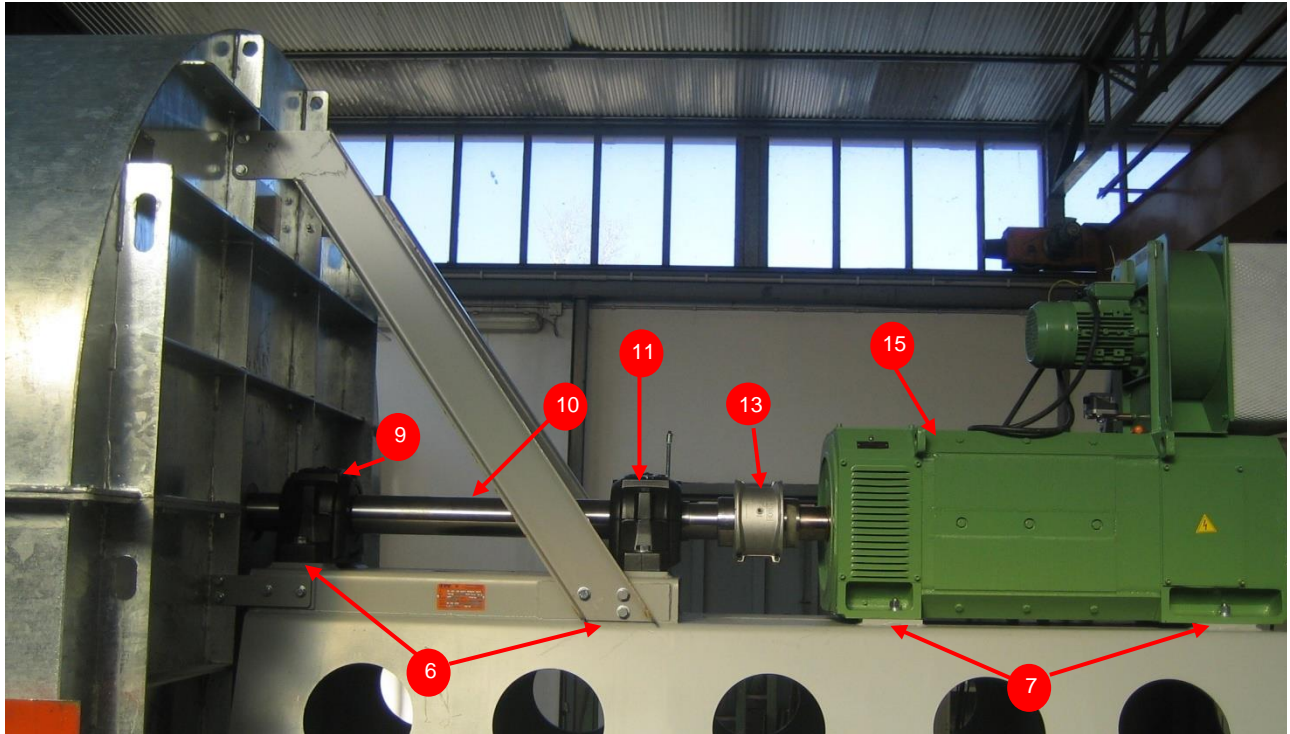


Photo 67

- 1.- Use markers to mark the position of the feet of the motor (7), so that after replacement of the coupling it can be returned to its original position.
- 2.- Dismantle the protection cover of the flexible coupling (14).
- 3.- Separate the two half-couplings (13).

To replace the coupling only, consult the instructions provided by the manufacturer. This documentation is provided by **FVI** together with the fan.



CAUTION:

If the user does not have the documentation for the flexible coupling, a copy can be requested from FVI.

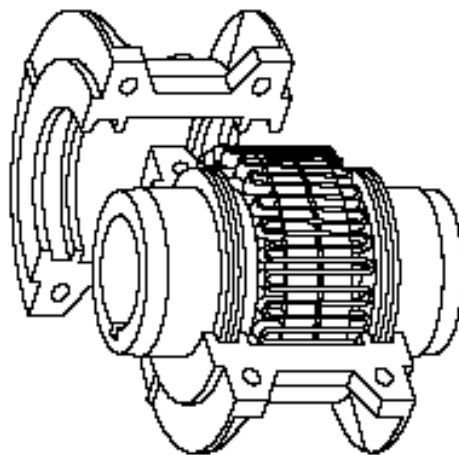


Fig. 10-14 Flexible coupling

- 4.- Move the motor (15) back and rotate it about 45° to provide sufficient space to replace the bearings easily. Use suitable lifting equipment for the weight of the motor to be moved.
- 5.- Remove the support guard (12), after removing any vibration and/or temperature sensors that are present.
- 6.- Mark the position of the cooling fan (8) on the fan shaft.
- 7.- Remove the cooling fan (8) to avoid damaging it during the following operations.
- 8.- Remove the intake (1), following the instructions given in paragraph 10.1.1 of this manual.
- 9.- Remove the impeller (2), following the instructions given in paragraph 10.3.1 of this manual. To facilitate this operation for fans with a casing in two parts, remove the upper part of the casing.

10.- Unscrew the fixing bolts and remove the upper parts of the supports (Photo 68).

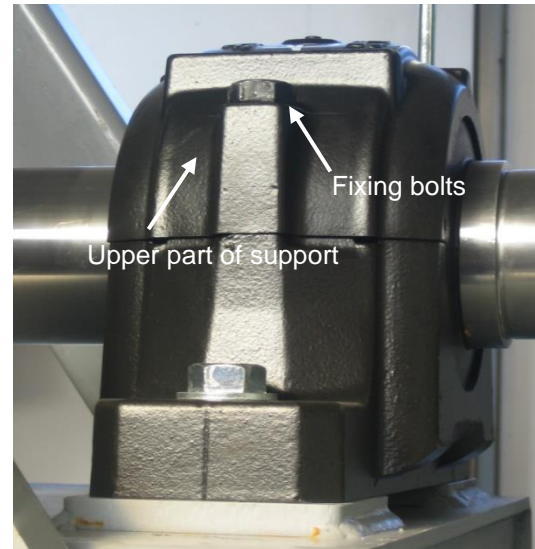


Photo 68

On fans with a one-piece support, this must be totally dismantled, following the instructions given in paragraph 10.5.2 of this instruction manual. Before this, use markers to mark the position of the support feet.

- 11.- Remove the shaft (10) complete with bearings. The transmission specifications document supplied with the fan gives details on the types of bearings installed in each support. These may be self-aligning ball bearings or spherical roller bearings with a cylindrical or tapered hole.
- 12.- Dismantle the bearings and remove them from the fan shaft.
- 13.- Carefully clean all components.
- 14.- Fit the new bearings onto the shaft in their exact previous position.
- 15.- Reassemble the shaft complete with bearings and seals.

For fans with a one-piece support, return the fully reassembled support to its initial position, using the markers positioned before disassembly. Follow the instructions given in paragraph 10.5.2 of this instruction manual.

- 16.- Close the upper part of supports and tighten the fixing bolts.
- 17.- Fit the impeller, following the instructions given in paragraph 0 of this manual. For fans with a casing in two parts, reassemble the top part of the casing.
- 18.- Fit the intake, following the instructions given in paragraph 10.3.2 of this instruction manual. Check that the intake is correctly centred with respect to the impeller, and adjust intake position if necessary.
- 19- Reassemble the half-coupling onto the transmission shaft.
- 20- Return the motor to its initial position, using the markers positioned before disassembly. Check the correct alignment of the coupling, following the instructions given in paragraph 8.5 of this instruction manual.

- 21.- If necessary for the type of coupling, fit the spring of the flexible coupling (Fig. 10-12), grease the various components and close the covers.
- 22.- Reassemble the cooling fan (8) in its initial position.
- 23.- Reassemble any vibration and/or temperature sensors if present.
- 24.- Replace the support guard (12) and the flexible coupling (14).

10.7 Replacement of stuffing box seal

10.7.1 Dismantling stuffing box seal

Seal replacement operations can normally be carried out with the impeller still fitted on the shaft. It is necessary to remove the impeller and move the motor or support back before starting replacement operations only in special cases.

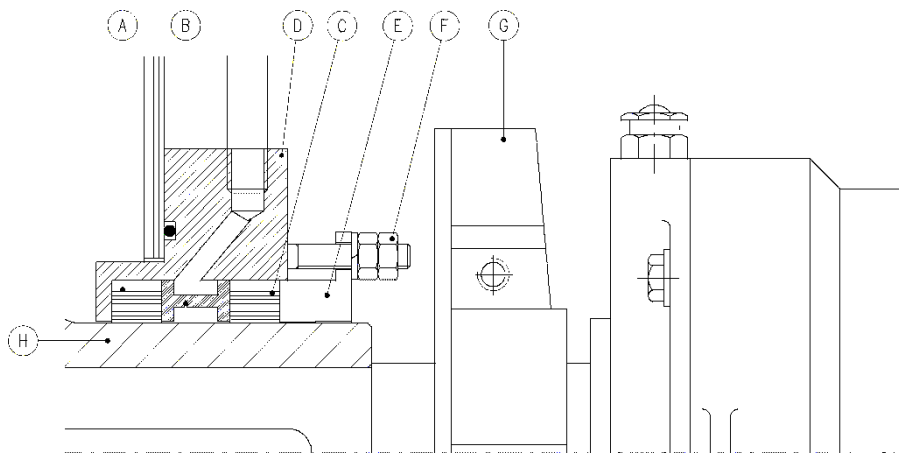


Fig. 10-15 Detail of seal

Proceed as follows to dismantle the stuffing box seal, using the references indicated in Fig. 10-15:

1.- Mark the relative positions of the stuffing box half-rings E and the stuffing box body D (Photo 69).



Photo 69

2.- Remove the two stuffing box half-rings by unscrewing the locknuts and nuts F securing them (Photos 70 and 71).



Photo 70



Photo 71

3.- On fans with cooling fan G, use markers to mark the position of the cooling fan on the shaft or on the hub of the impeller before dismantling it.

4.- Remove seals A and C to be replaced, and if present the gas blowing ring B (Photo 72). Seals may be of two types, in the form either of a braid or a tape.



Photo 72

10.7.2 Reassembling stuffing box seal

1.- Fit the new seal.

1.1 With braid seals, cut rings (at least two) to size and insert them between the stuffing box body and the hub (Photo 72).

	<p>CAUTION:</p> <p><i>Ensure that the slits in the rings are located in diametrically opposite positions (Fig. 10-16). If envisaged, fit the gas blowing ring between the sealing rings.</i></p>
--	---

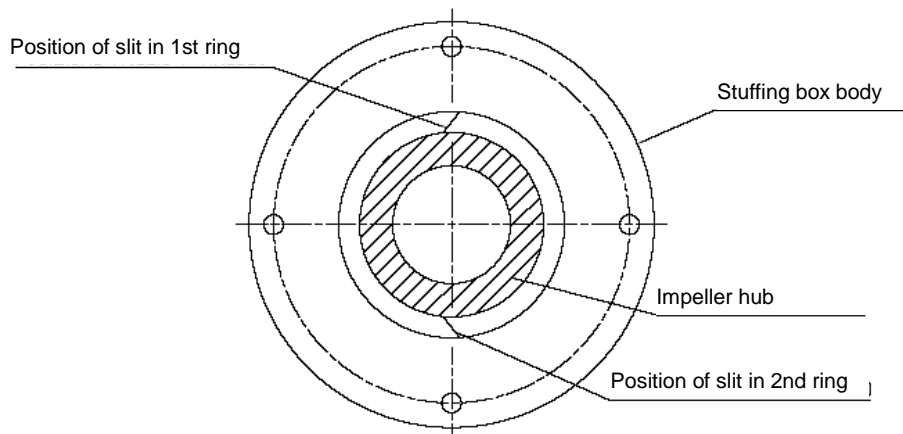


Fig. 10-16 Sealing ring slits

1.2 With tape seals, wind spirals around the impeller hub and push them into the stuffing box body. If envisaged, fit the gas blowing ring between the spirals.

2.- Fit the two stuffing box half-rings in their initial position before dismantling (Photo 73).



Photo 73

3.- Screw on the nuts and locknuts securing the stuffing box half-rings, using the tightening torque necessary to ensure correct slippage against the seals (Photo 74). The nuts should be tightened alternately and with care, ensuring that the stuffing box half-rings enter the stuffing box body, compressing the seal uniformly.

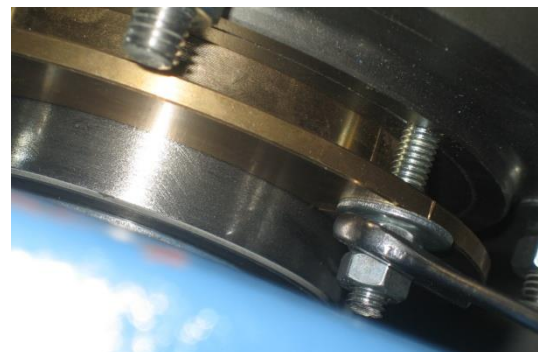


Photo 74

4.- Replace the cooling fan in its initial position.

11 FINAL DISMANTLING AND DISPOSAL OF FANS

At the end of the life cycle of the fan, the machine and its accessories must be dismantled as indicated below, so as to allow the various components to be disposed of differently according to the type of material from which they are made. Before demolishing the machine, the user must drain the grease present in bearing supports and generally clean the various components.

	<p>CAUTION:</p> <p><i>Particular attention must be dedicated to the possible presence of residues of toxic and/or corrosive substances left by the fluid moved.</i></p>
--	--

Most of the components (impeller, casing, motor pedestal, intake, base, bearings, guards, pulleys, bushes) are made of metallic materials (steel and cast iron), and can therefore be disposed of together.

The electric motor must instead be separated and disposed of at a facility specializing in the elimination of electrical wastes, together with any electric servomotors.

Drive belts are made from rubber, and vibration dampers are also made mainly from the same material.

Most of the accessories are also made from metals, except for anti-vibration joints, constituted by two metallic flanges bolted together and separated by a textile joint in PVC or aluminiumized glass fibre.

Fan dismantling operations can be carried out either in the place of installation, if the need for safe working conditions allows this, or in some other location, after removing and transporting the fan as indicated in Chapter 4 of this manual.

	<p>CAUTION:</p> <p><i>All dismantling operations must be carried out only by qualified and authorized personnel, equipped with the necessary PPE.</i></p>
--	--

	<p>CAUTION:</p> <p><i>All dismantling operations must be carried out</i></p> <ul style="list-style-type: none"> • <i>With the absolute certainty that the fan is at a complete standstill (impeller stationary), after the motor has been disconnected from the electrical power supply by qualified and authorized persons.</i> • <i>After having created a work environment with all necessary equipment and free from all other activities that could dangerously interfere with dismantling operations.</i>
--	--

	<p><i>Special or specific equipment is not necessary for the dismantling of fan parts.</i></p>
--	--

Dismantling operations can be carried out following the detailed assembly instructions given in Chapter 10 in the reverse order.

	<p>CAUTION:</p> <p>Regardless of the installation type, all components connected to the fan flange must be disconnected and removed before proceeding.</p>
--	---

11.1 Centrifugal fans with single intake versions 1-9-12

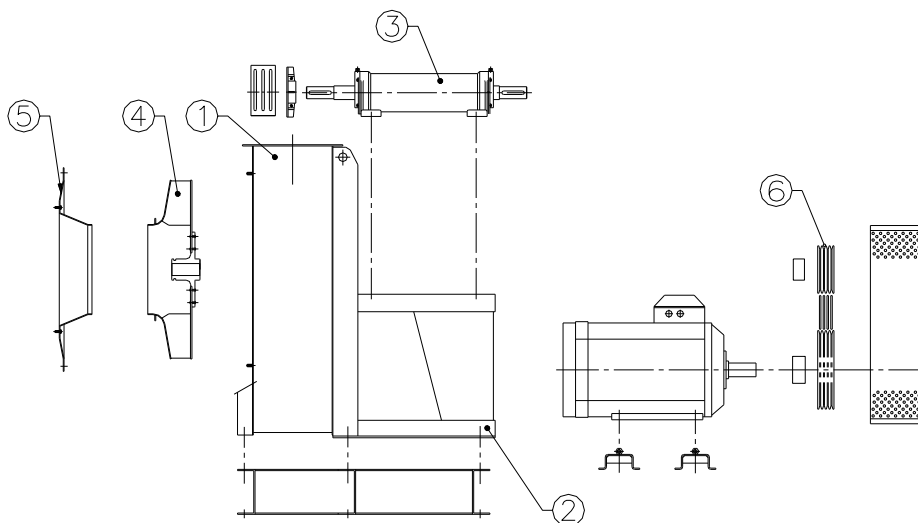


Fig. 11-1 Exploded view of version 12 fan

With reference to Fig. 11-1, the correct dismantling sequence is as follows:

- Guards and transmission components (paragraph 10.4)
- Intake 5 (paragraph 10.1.1)
- Casing 1 and 2 (paragraph 10.2)
- Impeller 4 (paragraph 10.3)
- Support 3 and cooling fan (if present) (paragraph 10.5)
- Seal (if present) (paragraph 10.7.1)
- Motor

11.2 Centrifugal fans with double intake versions 6 -18

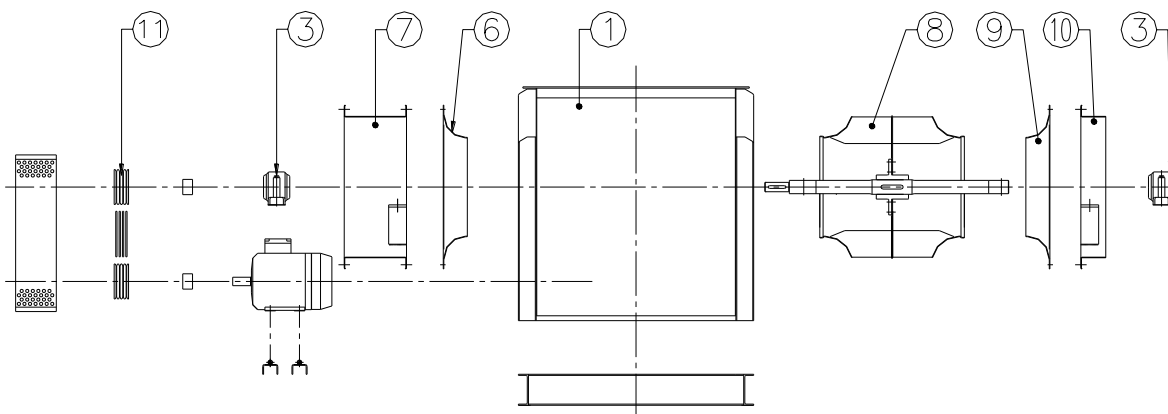


Fig. 11-2 Exploded view of centrifugal fan with double intake

With reference to Fig. 11-2, the correct dismantling sequence is as follows:

- Guards and transmission components (paragraph 10.4)
- Support casing on transmission side 3 (paragraph 10.5)
- Support drum 7
- Intake 6 (paragraph 10.1.1)
- Support casing opposite transmission side 3 (paragraph 10.5)
- Impeller 4 (paragraph 10.3)
- Support casing 3 (paragraph 10.5)
- Support drum 10
- Intake 9 (paragraph 10.1.1)
- Casing 1 (paragraph 10.2)
- Motor

11.3 Version 8 centrifugal fans

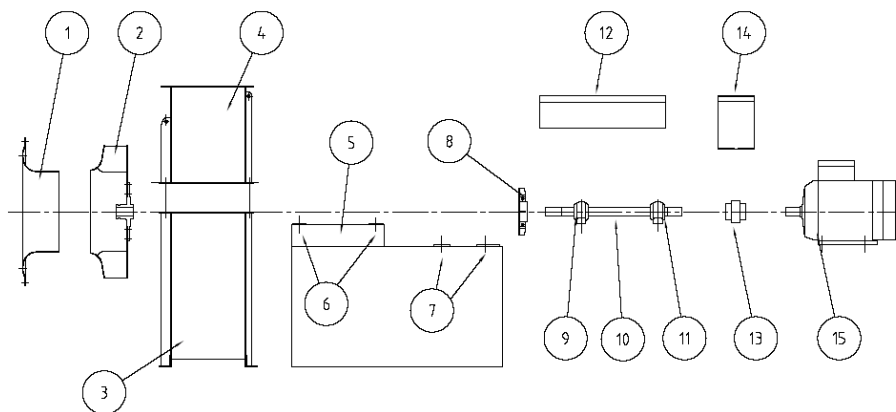


Fig. 11-3 Exploded view of version 8 fan

With reference to Fig. 11-3, the correct dismantling sequence is as follows:

- Guards 12-14
- Coupling 13 (paragraph 10.6)
- Motor 15
- Intake 1 (paragraph 10.1.1)
- Impeller 2 (paragraph 10.3)
- Supports 9 and 10 (paragraph 10.5)
- Cooling fan 8 (if present)
- Seal (if present) (paragraph 10.7.1)
- Casing 4 and 3 (paragraph 10.2)

12 TECHNICAL APPENDICES

12.1 Tightening torques for nuts and bolts

Tightening torques M of the chart are valid under the following conditions:

- Type UNI 5737 bolts with hexagonal heads, type UNI 5931 and UNI 6107 screws with cylindrical head, in normal conditions of supply.
- Tightening torques are assumed to be applied slowly with a torque wrench.

While maintaining the same pre-stressing values, tightening torques must be varied as follows in these cases:

- increased by 5% for UNI 5712 bolts with extra-wide heads
- reduced by 10% for oiled galvanized bolts
- reduced by 20% for oiled phosphate-treated bolts
- reduced by 10% if bolts are tightened with an impact wrench.

D x pitch mm			Sr mm ²	8.8	10.9	12.9	A2/A4-70	A2/A4-80
				M Nm	M Nm	M Nm	M Nm	M Nm
6	x	1	20,1	10,4	15,3	17,9	8,8	11,8
7	x	1	28,9	17,2	25	30	-	-
8	x	1,25	36,6	25	37	44	21,4	28,7
10	x	1,5	58	50	73	86	44	58
12	x	1,75	84,3	86	127	148	74	100
14	x	2	115	137	201	235	119	159
16	x	2	157	214	314	368	183	245
18	x	2,5	192	306	435	509	260	346
20	x	2,5	245	432	615	719	370	494
22	x	2,5	303	592	843	987	488	650
24	x	3	353	744	1060	1240	608	810
27	x	3	459	1100	1570	1840	-	-
30	x	3,5	561	1500	2130	2500	-	-

Chart 12-1 Tightening torques M for bolts with ISO metric threads



12.2 Checklist before starting fans

The checks listed below are necessary, but could be insufficient in environments with particular types of risk.

CHECKLIST BEFORE STARTING FANS		
CODE	SERIAL NUMBER	YEAR
Identify installation type in accordance with paragraph 3.1.		A <input type="checkbox"/> B <input type="checkbox"/> C <input type="checkbox"/> D <input type="checkbox"/>
Check compatibility of fan with type of application.		OK <input type="checkbox"/>
Check that the fan and motor identification plate data are compatible with the data on the transmission information card (if present).		OK <input type="checkbox"/>
Check the compatibility of the electrical data of the motor identification plate with the electrical power supply (frequency, voltage, connections); for further checks consult the motor instruction manual.		OK <input type="checkbox"/>
Check the efficiency of any power switch installed for the electrical power supply to the motor and any auxiliary circuits (e.g. heaters).		OK <input type="checkbox"/>
Check for absence of foreign bodies inside fan.		OK <input type="checkbox"/>
Check for presence of all nuts, bolts and other fasteners envisaged.		OK <input type="checkbox"/>
Check tightness of nuts and bolts in accordance with Chart 12-1 (impeller, supports, foundations, transmission if present).		OK <input type="checkbox"/>
Check for the efficiency of interblock on access door to room or on safety barriers (if necessary).		OK <input type="checkbox"/>
Check lubrication conditions of bearings (including motor bearings if these can be lubricated).		OK <input type="checkbox"/>
Check alignment of flexible coupling (if present). See paragraph 8.5		OK <input type="checkbox"/>
Check that all rotating parts can turn freely.		OK <input type="checkbox"/>
Check directions of fan rotation and fluid flow.		OK <input type="checkbox"/>
Check availability of safety procedure for access to fan.		OK <input type="checkbox"/>
Check that personnel have been instructed and trained.		OK <input type="checkbox"/>
Date:		
Signature:		

12.3 Programmed maintenance intervals

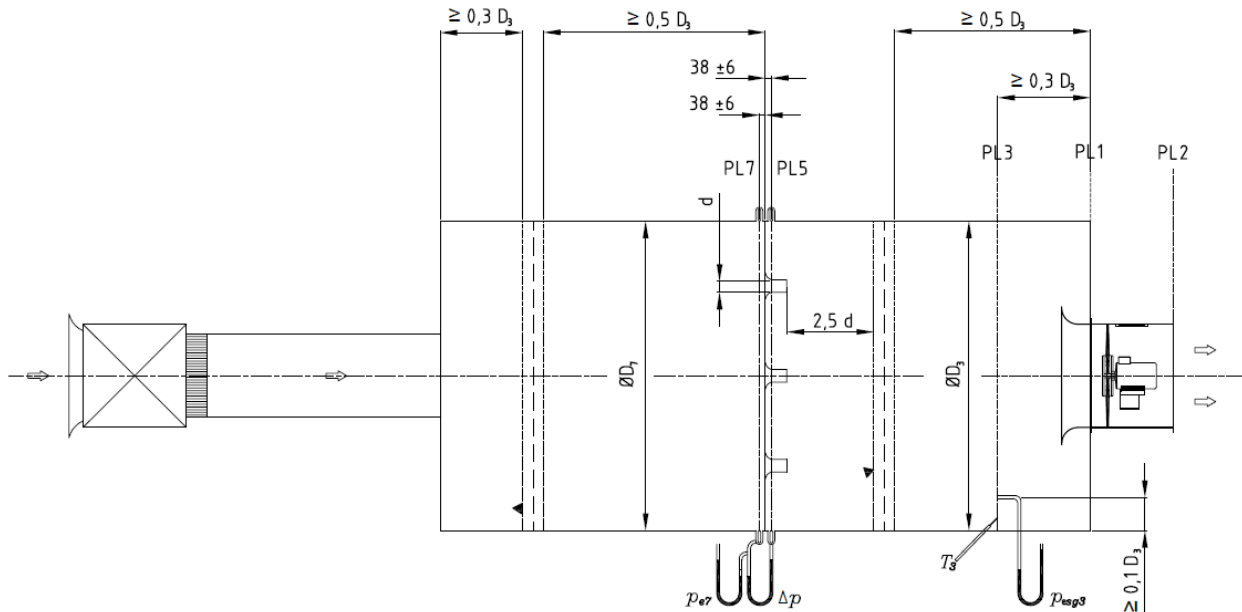
The intervals of time suggested constitute a working basis for the customer, who must according to circumstances make any modifications necessary for the specific operating conditions.

Programmed maintenance intervals according to intensity of use				
		Intensity of use		
		High	Medium	Low
For all fans				
1	Check perfect condition of all guards and warning symbols. See paragraphs 1.3 and 6.2.1	1 month	1 month	1 month
2	Check correct tightness of all nuts and bolts in accordance with Chart 12-1, above all in presence of cyclical thermal gradients	1 month	3 months	6 months
3	Check that the impeller is free from defects due to wear and corrosion. See paragraphs 6.2.2 and 6.2.3	1 month	3 months	6 months
4	Check that impeller is clean	1 month	6 months	12 months
5	Check for absence of dangerous vibrations. See also paragraph 3.8.4	1 month	6 months	12 months
6	Check for absence of abnormal noise	1 month	6 months	12 months
7	Check for correct lubrication of motor bearings. See paragraph 8.1	1 month	6 months	12 months
8	Check electrical operating parameters of motor and servomotors installed	1 month	6 months	12 months
9	Check cleanness of filter	1 month	6 months	12 months
10	Check perfect condition of all accessories installed	1 month	6 months	12 months
Additional maintenance for fans with belt-drive transmission				
11	Check tension and wear of drive belts. See paragraph 8.4	1 month	3 months	6 months
12	Check condition of lubrication of bearings in accordance with paragraph 8.1	See also transmission information card		
13	Check temperature of supports containing bearings. After an initial increase due to running in, temperature values should remain constant over time.	1 month	3 months	6 months
Additional maintenance for fans with flexible coupling transmission				
14	Check alignment and lubrication of coupling. See paragraph 8.5	1 month	6 months	12 months

12.4 Energy efficiency measurement system

The energy efficiency of the fan in accordance with Directive 2009/125/EU – Regulation (EU) 327/2011 must be calculated by carrying out a performance trial on the machine in conformity with the ISO 5801 standard.

The measurement must be made with an intake chamber following the layout below (type e installation – measurement with multi-nozzle chamber pursuant to point 30 of the UNI EN ISO 5801 standard):



NB: For series PFB-PFM fans (so-called “plug fans” with a free impeller), energy efficiency in accordance with Directive 2009/125/EU must be calculated with the casing.

13 INDEX

- abrasion; 74
- accessories; 20; 26; 37; 45; 46; 139; 145
- acoustics; 10; 13; 43; 47; 48; 49; 50
- air; 13; 15; 16; 22; 26; 38; 39; 45; 76; 77; 78
- alignment; 63; 68; 88; 116; 117; 119; 120; 134; 144; 145
- angle; 55; 86
- assembly; 3; 7; 8; 28; 29; 30; 31; 32; 33; 34; 36; 54; 59; 62; 63; 64; 66; 68; 70; 71; 84; 86; 91; 100; 106; 110; 120; 127; 134; 140
- ATEX; 23; 36; 37
- balance; 63
- base; 3; 13; 16; 20; 22; 25; 26; 37; 59; 80; 120; 139; 145
- bearings; 4; 5; 8; 10; 16; 20; 24; 40; 43; 58; 62; 64; 68; 70; 72; 73; 78; 80; 82; 83; 84; 85; 86; 94; 96; 97; 99; 121; 122; 123; 124; 125; 126; 128; 129; 130; 131; 133; 134; 139; 144; 145
- belts; 4; 5; 8; 10; 15; 16; 20; 24; 38; 41; 55; 64; 66; 68; 73; 78; 79; 87; 88; 113; 117; 119; 120; 121; 139; 145
 - tension; 8; 55; 64; 66; 87; 88
- blades; 4; 13; 43; 74; 75
- bushes; 62; 68; 96; 97; 99; 113; 114; 115; 117; 131; 139
- casing; 4; 7; 10; 16; 20; 22; 23; 33; 34; 38; 39; 53; 54; 57; 58; 61; 62; 63; 64; 66; 72; 74; 92; 101; 102; 103; 104; 105; 108; 111; 133; 134; 139; 146
- chains; 51; 52; 55; 57
- characteristics; 13; 14; 22; 37; 40; 42; 43; 60; 70; 80; 88
- checks; 4; 20; 24; 37; 40; 41; 58; 60; 63; 68; 69; 72; 73; 74; 75; 91; 144
- classification; 40
- cleaning; 4; 5; 39; 68; 74; 87; 88; 91; 92; 114; 139; 145
- components; 7; 20; 21; 24; 38; 40; 41; 43; 66; 130; 134; 139
- connection; 3; 5; 8; 20; 25; 28; 29; 31; 36; 38; 42; 52; 60; 64; 69; 70; 91; 100; 103; 144
- connector; 69
 - grounding; 69
- control; 20; 40; 41; 69; 100
- cooling fan; 8; 15; 20; 122; 133; 134; 136; 138; 140
- corrosion; 74; 145
- coupling; 5; 10; 42; 62; 78; 88; 89; 104; 132; 134
- couplings; 5; 8; 10; 14; 15; 16; 20; 36; 41; 55; 59; 60; 64; 68; 70; 71; 79; 89; 91; 121; 131; 132; 134; 139; 144; 145
 - anti-vibration; 36; 59; 60; 139
 - flexible; 14; 20; 79; 131; 132; 134; 145
 - flexible; 5; 8; 10; 55; 64; 68; 70; 71; 89; 91; 131; 132; 144
 - covers; 123; 125; 127; 131
 - cycle; 24; 40; 42; 74; 139
 - life cycle; 24; 40; 42; 139
 - diameter; 62; 87; 108; 110
 - directives; 23; 36; 37; 69; 79; 126; 146
 - dismantling; 5; 63; 100; 105; 106; 113; 119; 122; 132; 133; 134; 135; 137; 139; 140; 141
 - ducts; 4; 5; 7; 8; 22; 25; 26; 28; 29; 31; 36; 39; 46; 60; 61; 63; 70; 71; 76; 91; 100; 103
 - duration; 24; 80
 - dust; 22; 36; 39; 58; 74; 92
 - efficiency; 6; 26; 37; 126; 144; 146
 - energy; 6; 126; 146
 - emissions; 4; 43; 44
 - acoustics; 4; 43; 44
 - energy; 13; 20; 22; 72; 73
 - environment; 3; 37; 38; 39; 44; 45; 46; 74; 100; 121; 126; 139; 144
 - equipment; 51; 59; 60; 80; 100; 106; 109; 139
 - exit; 13; 22; 25; 28; 29; 31; 34; 36; 38; 45; 46; 60; 70; 91
 - explosion; 23; 37
 - fan; 1; 3; 4; 5; 7; 8; 9; 10; 11; 12; 13; 14; 15; 16; 17; 18; 20; 21; 22; 23; 24; 25; 26; 27; 28; 29; 31; 32; 34; 36; 37; 38; 39; 40; 41; 42; 43; 44; 45; 51; 52; 53; 54; 55; 56; 57; 58; 59; 60; 61; 62; 63; 64; 65; 66; 67; 68; 69; 70; 71; 72; 73; 74; 76; 77; 79; 80; 82; 84; 88; 91; 92; 93; 96; 97; 99; 100; 103; 105; 106; 120; 121; 126; 131; 132; 133; 134; 136; 139; 140; 141; 144; 145; 146
 - filters; 91; 145
 - fixing; 3; 7; 10; 28; 29; 31; 32; 33; 34; 35; 37; 38; 40; 59; 60; 62; 63; 64; 73; 74; 101; 104; 106; 113; 114; 120; 123; 133; 134; 135; 138
 - flange; 28; 31; 63; 105; 139; 140
 - flow capacity; 51; 57; 61; 77
 - flow; 13; 22; 77
 - fluid; 4; 5; 12; 13; 20; 22; 23; 36; 37; 38; 43; 60; 71; 74; 76; 79; 91; 92; 120; 139
 - hot; 12; 38; 79
 - friction; 117; 138
 - gaskets; 64; 70; 103; 131
 - grease; 10; 62; 70; 72; 80; 82; 83; 84; 111; 126; 130; 139



grounding; 69

guards; 3; 4; 7; 10; 12; 20; 24; 25; 26; 28; 29; 30; 31; 32; 34; 35; 36; 37; 38; 39; 40; 64; 66; 72; 73; 74; 120; 133; 134; 139; 145

holes; 7; 10; 33; 34; 38; 52; 53; 55; 56; 64; 68; 92; 103; 106; 107; 108; 111; 113; 114; 115; 117; 134

hub; 43; 63; 107; 108; 111; 112; 136; 137

identification plate; 1; 7; 13; 18; 22; 37; 60; 61; 70; 71; 72; 76; 82; 92; 144

imbalance; 78

impeller; 5; 8; 13; 20; 22; 24; 38; 39; 41; 43; 45; 58; 62; 63; 66; 72; 73; 74; 76; 78; 79; 92; 94; 100; 104; 106; 107; 108; 109; 110; 111; 112; 113; 121; 122; 123; 124; 128; 129; 133; 134; 136; 137; 139; 144; 145; 146

inspection; 12; 39; 74; 78; 79

installation; 3; 11; 23; 25; 26; 27; 28; 29; 31; 36; 37; 38; 39; 40; 41; 44; 45; 46; 59; 60; 69; 70; 73; 77; 89; 91; 126; 139; 140; 144; 146

intake; 4; 5; 6; 7; 8; 9; 10; 16; 20; 22; 25; 26; 28; 29; 31; 32; 36; 38; 45; 48; 50; 55; 60; 61; 62; 63; 66; 67; 70; 71; 76; 77; 91; 100; 101; 102; 103; 104; 126; 133; 134; 139; 140; 141; 146

interference; 100; 139

inverter; 41; 78

lifting lugs; 54; 55; 56; 100; 101; 103

lifting; 4; 7; 8; 12; 37; 51; 52; 53; 54; 55; 56; 57; 58; 80; 100; 103; 106; 107; 108; 109; 110; 111; 112; 133

load; 10; 51; 52; 55; 57; 59; 60; 87; 88; 91

lubricants; 80; 88

lubrication; 12; 39; 72; 79; 80; 82; 88; 89; 144; 145

interval; 80; 82

maintenance; 3; 24; 26; 27; 39; 42; 60; 69; 79; 80; 83; 88; 91; 100

materials; 23; 43; 74; 78; 91; 92; 107; 139

meshes; 7; 10; 26; 28; 29; 31; 32; 33; 34; 69; 70; 73

misalignment; 59; 116

motor pedestal; 15; 16; 20; 62; 63; 64; 68; 105; 120; 139

motor; 3; 13; 14; 15; 16; 17; 20; 22; 27; 38; 41; 42; 43; 45; 46; 52; 53; 54; 55; 56; 62; 69; 70; 72; 76; 78; 79; 82; 106; 107; 110; 111; 112; 113; 115; 116; 119; 120; 132; 133; 134; 139; 144; 145

electric; 14; 22; 42; 69; 70; 139

movement; 4; 12; 37; 51; 57; 80

multi-stage; 79

noise/noisiness; 4; 13; 40; 43; 44; 45; 46; 72; 117; 145

nuts and bolts; 3; 6; 26; 32; 40; 59; 60; 62; 63; 72; 73; 74; 120; 139; 143; 144; 145

nuts; 10; 28; 29; 33; 101; 104; 105; 135; 138

oil; 39

operation; 13; 20; 24; 37; 39; 40; 41; 42; 43; 45; 51; 59; 64; 72; 73; 74; 76; 77; 78; 80; 88; 89; 92; 120; 145

paint/paintwork; 22; 74; 75

parts; 12; 20; 27; 37; 38; 40; 42; 74; 76; 101; 111

lifting equipment; 101; 111

personal protective equipment (PPE); 35; 41; 47; 48; 55; 80; 116

pipes; 8; 106; 107; 108; 110; 111; 112

play; 8; 10; 16; 62; 63; 84; 85; 86; 88; 110; 115

positions; 3; 15; 16; 17; 26; 43; 44; 52; 55; 57; 60; 62; 76; 93; 104; 108; 116; 124; 129; 132; 133; 134; 135; 136; 137; 138

power supply; 22; 39; 42; 69; 70; 78; 79; 144

voltage; 69; 76

power; 13; 42; 44; 45; 69; 76; 117

acoustic; 13; 45

absorbed; 13; 117

nominal; 13

pressure; 5; 8; 13; 23; 44; 45; 46; 76; 77; 91; 104

acoustic; 13; 14; 44; 45; 46

atmospheric; 23

dynamic; 13

resistance; 76; 77

static; 13

pre-tension; 88

pulleys; 5; 8; 20; 38; 41; 55; 64; 66; 68; 79; 83; 87; 113; 114; 115; 116; 117; 119; 120; 121; 125; 139

qualified personnel; 51; 59; 60; 69; 79; 100; 139

range; 13; 27; 43; 61

reassembly; 63; 91; 100

recess; 114; 124; 125; 129

reliability; 24; 79

removal; 12; 26; 37; 38

ring; 9; 73; 83; 123; 124; 125; 126; 127; 128; 129; 130; 131; 136; 137

blowing ring; 136; 137

spring locking ring; 124; 125; 128; 129

external ring; 73; 83; 125; 130

internal ring; 124; 126; 128; 129

spring locking ring; 124

risks; 3; 11; 23; 25; 26; 27; 37; 38; 39; 40; 41; 44; 45; 52; 57; 74; 144

rotation direction; 43; 57

rotation; 13; 20; 22; 39; 41; 42; 43; 45; 69; 72; 73; 76; 78; 83

direction; 16; 69; 72; 76; 144

safety; 3; 11; 12; 24; 25; 27; 37; 40; 41; 55; 57; 69; 72; 73; 74; 79; 80; 108; 139; 144

screws; 10; 28; 29; 31; 32; 34; 35; 37; 38; 63; 68; 100; 102; 103; 105; 106; 113; 115; 117; 120; 123; 125; 133; 134; 138; 143

seals; 5; 9; 23; 36; 38; 63; 64; 66; 103; 106; 123; 127; 131; 134; 135; 136; 137; 138

stuffing box; 5; 134; 135; 136; 137; 138

sensors; 73; 133; 134

serial number; 28; 29; 31; 92

series; 5; 8; 10; 17; 22; 28; 29; 63; 88; 96; 97; 99; 104; 146

shaft; 5; 15; 20; 38; 41; 62; 63; 66; 68; 80; 94; 106; 107; 110; 111; 112; 113; 114; 115; 121; 122; 123; 124; 126; 127; 128; 129; 130; 131; 133; 134; 136

slipping; 88

speed; 3; 8; 13; 24; 38; 40; 41; 42; 43; 45; 48; 50; 57; 70; 73; 76; 78

nominal; 43

spline; 111; 112; 114; 115

standards; 40; 44; 69; 126; 146

steel; 43; 139

stainless steel; 43

stuffing box; 135; 136; 137; 138

supports; 5; 10; 16; 20; 55; 59; 60; 62; 63; 64; 66; 72; 73; 80; 82; 121; 122; 123; 124; 125; 126; 127; 128; 129; 131; 133; 134; 139; 141; 144; 145

one-piece; 5; 121; 126; 133; 134

surfaces; 38; 45; 57; 62; 63; 64; 66; 79; 111; 114

symbols; 12; 37; 52; 53; 55; 56; 145

system; 22; 23; 25; 26; 36; 38; 69; 72; 76; 77; 91

temperature; 3; 15; 16; 20; 36; 38; 40; 43; 63; 64; 66; 72; 73; 79; 83; 88; 126; 128; 133; 134; 145

high/high; 12; 27; 36; 39; 63; 64; 66; 92

thickness; 75; 108

tightening torques; 113; 143

tightening; 6; 10; 26; 59; 60; 68; 72; 73; 86; 104; 117; 118; 143; 144; 145

tools; 26; 115; 119

transmission; 4; 5; 8; 14; 15; 16; 20; 24; 36; 38; 41; 42; 43; 45; 46; 66; 68; 72; 73; 79; 80; 87; 88; 94; 113; 115; 117; 120; 121; 122; 123; 124; 125; 126; 127; 128; 129; 130; 134; 139; 140; 141; 144; 145

transmission; 5; 10; 82; 96; 97; 99

transport; 22; 51; 68; 74; 80; 92

use/use; 3; 14; 22; 23; 24; 26; 32; 37; 38; 41; 42; 43; 52; 59; 70; 73; 79; 88; 92; 145

conditions of; 42

improper; 3; 37

intended; 22

intense; 145

version; 4; 5; 6; 7; 8; 9; 10; 15; 16; 21; 52; 53; 54; 55; 56; 59; 61; 62; 63; 64; 65; 66; 80; 94; 95; 96; 120; 131; 132; 140; 141

vibrations; 3; 13; 22; 26; 36; 38; 39; 40; 42; 44; 59; 60; 62; 72; 73; 74; 92; 110; 117; 133; 134; 145

washer; 106; 107; 112; 113

wear; 24; 26; 39; 74; 88; 92; 117; 145

welds; 60; 73; 74