

wybone

Mr.
FILL



The smart waste solution



At Wybone, we believe in smart, effective and sustainable waste solutions.

That's why we're proud to continue our strong partnership with Netherlands-based smart waste solution, Mr. Fill.



Mr. Fill: Smart Waste Solution

We're always keen to find new ways of expanding and demonstrating our expertise in the waste market, we believe the Mr. Fill Smart Waste Solution perfectly encompasses the brains and brawn of what we hope to achieve!

Not only has our long-standing partnership made us the first UK's sole distributor of this exciting technology, but it's also made better with its stylish design and user-friendly features.



Two Sizes To Choose From

Mr. Fill comes in sizes 120L and 240L with the options for wheelie bin or bin liner, so you can find the right size for the ideal location that suits your preferences.

Easy To Use

Using Mr. Fill has never been easier. No need to use your hands to open the flap, simply press the foot pedal that's been made with durability in mind.

Fill To Your Heart's Content

The bin has a compacting force of 600kg no matter the waste type. This can compact waste from one-fifth to one-seventh of its size to avoid frequent emptying.

Automatic Lock

Staying on top of bin maintenance in busy, public areas can be tricky. Mr. Fill has a three-stage, colour-coded fill level indicator. When the indicator is red, it locks itself.



Smart City Manager

The Smart City Manager is a monitoring system that registers the status and usage of your waste bin. This means you can find out how often your bin is being used and when it needs emptying.

Audible Thank You Message

It's important to give back. Mr. Fill has an optional feature of adding a personalised 'thank you' message for the public when disposing of their waste.

Innovative solar technology

With a great return on energy, the smart infrared technology enables energy to be collected without direct sunlight.

The Mr. Fill Smart Sensor is a smart (no pun intended) sensor device that you can attach to almost any litter bin. It collects information on one data platform: the Smart City Manager.

Manufactured with high-quality components to maximise performance, the smart sensor lets you know how full the bin is at any given time and whether there are any potential hazards or blockages in the bin.

Mr. Fill: Smart Sensor

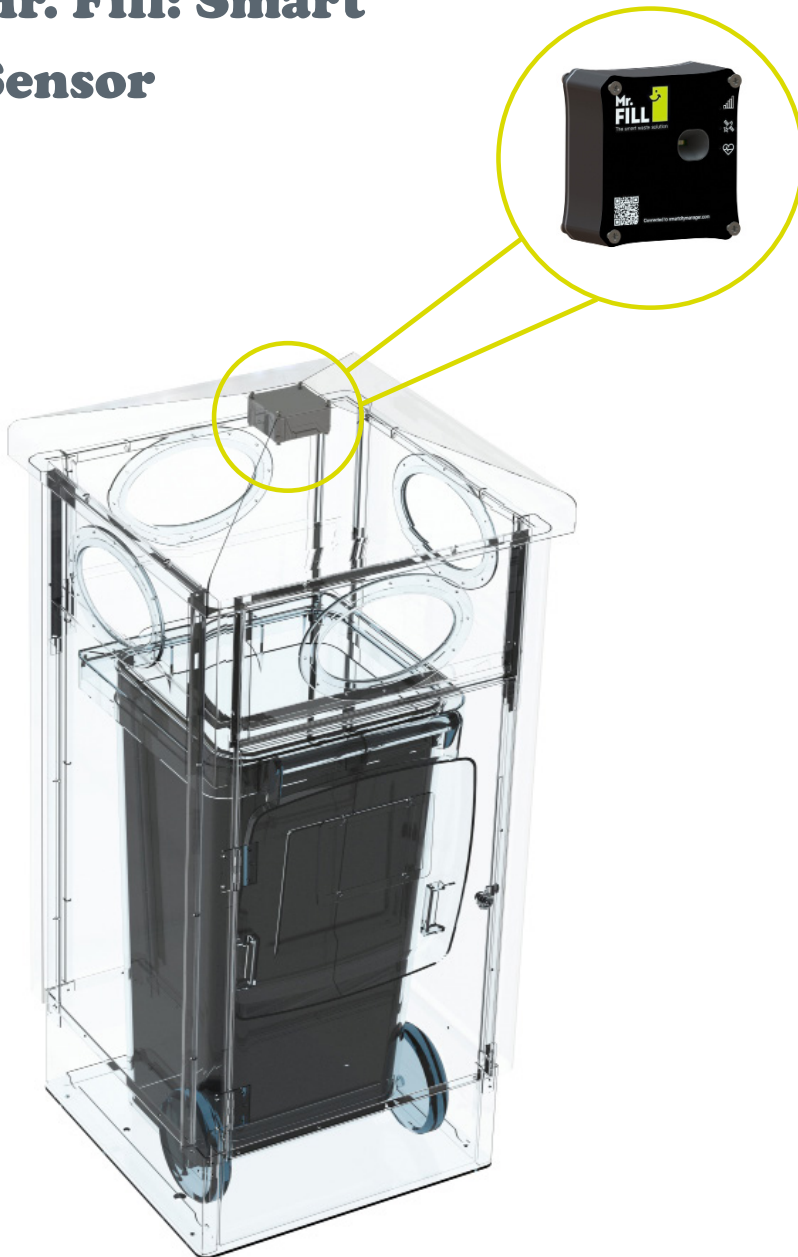

Does The Hard Work For You

With the smart sensor doing the hard work for you, you'll know how often your bin is being used and when it needs emptying.

Strong Battery Life

Make the most out of your smart sensor with a battery life of five to ten years with daily usage.

Withstand Any Weather

Mr. Fill's sensor can withstand any rainy weather conditions while remaining in pristine condition. It's also designed to work in extremely varied temperatures.

Track The Location Of Your Bin

The built-in GPS tracks the location of your litter bin, 24-hours a day. This means that operatives can easily find your compactor when it's ready for emptying.

Excellent Data Storage

The data collected by the smart sensor is updated every 10 minutes via the Smart City Manager, so you can be kept up to date frequently with everything you need to know.

Cutting-edge Laser Technology

The sensor works through laser technology that scans every item that is deposited into the bin, ensuring that accurate fill-level information is provided.

Adjustable Distance Measurement

The sensor's distance measurement ranges from 0-400cm - this can be easily adjusted to give accurate results that best suit the unit.

The Size

The smart sensor has a height of 10cm and a width of 9cm.

We understand that you may want your products to be diverse with additional features that are unique to you. That's why we offer optional additions and artwork so you can get the most out of your Mr. Fill.

Choose How You Want Your Mr. Fill

1 **Text Options**
Let your Mr. Fill have its say:

LITTER

Laser Cut Gold | LC/LIT/GLD
Laser Cut Silver | LC/LIT/SIL

Vinyl Gold | V/LITT/GLD
Vinyl Silver | V/LITT/SIL

2 **Artwork Options**
Have your Mr. Fill unique to you.

Customise with your
Logo/Artwork

Contact us directly for a quotation.

Call: 01226 744010



Tidyman Logo

Laser Cut Gold | LC/TM/GLD | £5.00
Laser Cut Silver | LC/TM/SIL | £5.00

Vinyl Gold | V/TM/GLD | £3.00
Vinyl Silver | V/TM/SIL | £3.00

3 **Give Mr. Fill Something Extra**
For a high-quality touch.

Vinyl Banding

Gold | Band/GLD | £12.00 per band

Silver | Band/SIL | £12.00 per band

Vinyl banding around the circumference of the bin.

4 **Optional Ashtray**
Let Mr. Fill handle it.

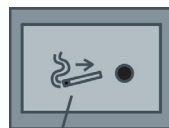

Stainless Steel Ashtray

Contact us directly for a quotation

Call: 01226 744010

5 **Choose Your Size**
It's always good to have variation.



Sizes: 120L and 240L

Wheelie bin and/or bin liner options available.

Call: 01226 744010

If you have any queries about any of the available options to choose from when ordering your Mr. Fill bin, please do not hesitate to get in touch.

With the different Mr. Fill sizes to choose from, it's important to us that you know exactly what you're getting.

Technical Specification: 120 Litres

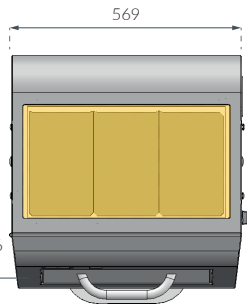
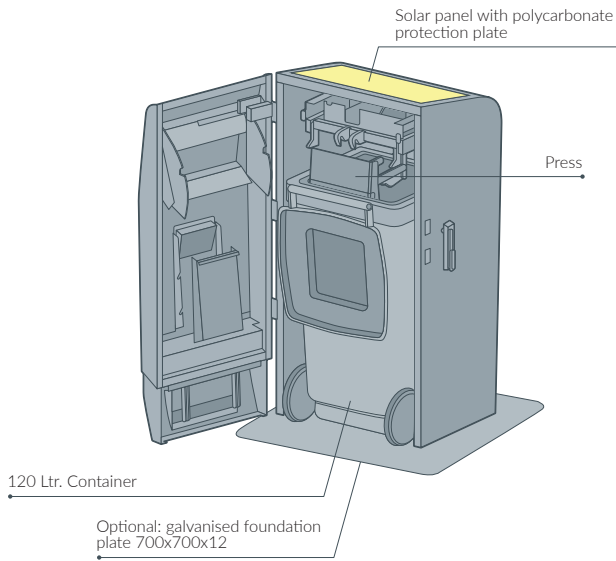

RGB display
Green: Available
Orange: Almost full
Red: Full, automatically closes

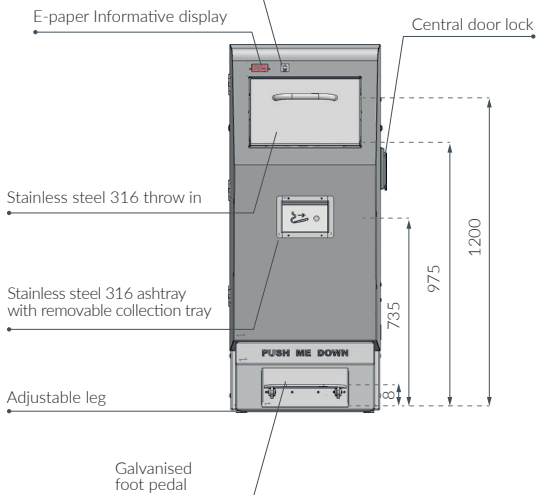

Technical Data	Mr. Fill 120 Litres
Dimensions	1385 x 569 x 569mm
Height of opening	1200mm
Dimensions of base plate	700 x 700 x 12mm
Weight	140kg

Material

Body and door	2mm high quality galvanised steel
Body and roof	Powder coating
Insertion valve	Stainless steel 316, 1.5mm thickness
Press	Electric press
Actuator	400N / 600N

Standard

Standard	Optional
Standard 120L unit	Galvanised foot pedal
Communication platform LTM-L1 / LTM-NB 2G / 3G	Communication platform 4G
Stainless steel throw in	Stainless steel ashtray with removable collection tray
Press	Personalised display
Colour - RAL 7016	Stainless steel unit
Solar panel	Colour preference
Two keys	
Localisation	
Display	

With the different Mr. Fill sizes to choose from, it's important to us that you know exactly what you're getting.

Technical Specification: 240 Litres

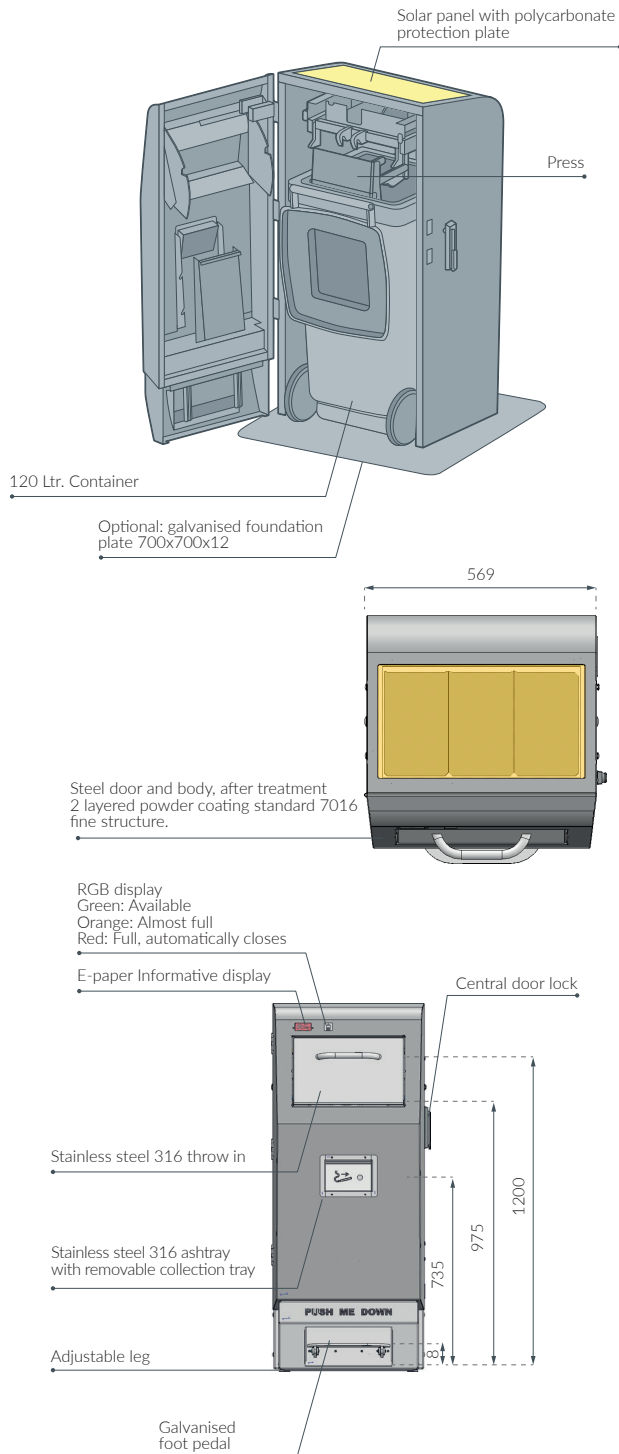

Technical Data	Mr. Fill 240 Litres
Dimensions	1530 x 668 x 765mm
Height of opening	1250mm
Dimensions of base plate	990 x 990 x 10mm
Weight	160kg

Material

Body and door	2mm high quality galvanised steel
Body and roof	Powder coating
Insertion valve	Stainless steel 316, 1.5mm thickness
Press	Electric press
Actuator	600N

Standard

Optional

Standard 240L unit	Galvanised foot pedal
Communication platform LTM-L1 / LTM-NB 2G / 3G	Communication platform 4G
Stainless steel throw in	Stainless steel ashtray with removable collection tray
Press	Personalised display
Colour - RAL 7016	Stainless steel unit
Solar panel	Colour preference
Two keys	
Localisation	
Display	