

Company Overview

- 40 Years industry experience
- Quality manufacturing
- Full technical support and advice
- Loler testing
- Extensive product range
- Off the shelf and custom solutions
- On site product training



About Us

Established in 1974, we entered the material handling market as one of very few suppliers, with an initial product range of forklift scoops, fork extensions and lifting jibs. Our product range has grown since those early days, and we now offer one of the largest ranges of material handling equipment in the UK.

Quality has always been at the core of our business, and we pride ourselves on offering our customers the very best products which provide true value for money.

Our enviable reputation in the industry is a result of consistently providing the highest standards of services to our customers.

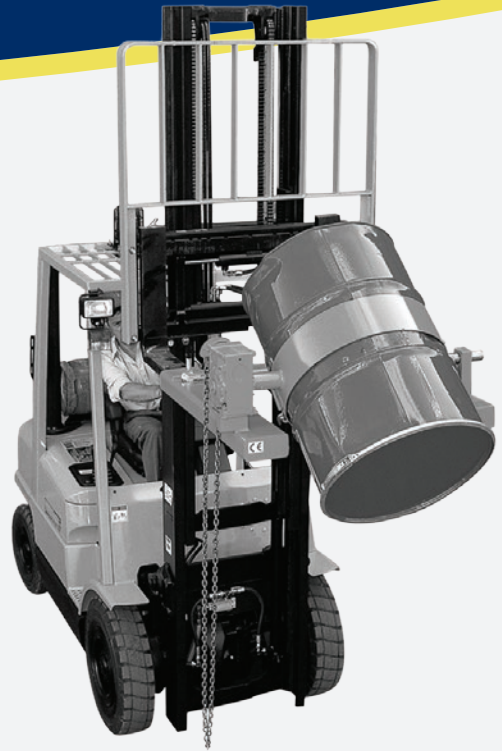

1985 - Early model drum rotator

UKAS Accredited

Our impact on the environment, small that it may be, has not gone overlooked by our Health & Safety manager here at CONTACT. We're UKAS accredited for the environmental standard BS 8555-2003 under the British environmental management system.



Our Products

Waste Handling

Waste handling can be so much more cost effective when using the right attachments. Our tipping skips, wheelie bin handlers and bottom dropping boxes are just some of the solutions we can offer.



Lifting Equipment

Manufactured to the highest quality, our lifting equipment ranges from jibs and fork mounted hooks, to spreader beams and bag handlers.

Access Equipment

Our range of access equipment and goods transfer platforms take the risk out of working from height, and are ideal for unscheduled building maintenance, safe product movement, or dockside emergency rescue.



Drum Handling

If you are working with drums, then we have a range of drum grab attachments and rotators that can make it easy.

...and many more

Custom Design Solutions

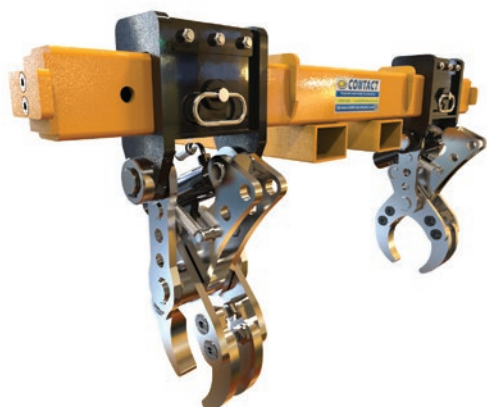

If you can't find an 'off the shelf' solution to your material handling problem, then don't despair - our innovative design team can make an attachment for you, tailored specifically for your needs.

With a proven track record of helping many of our customers across the UK, our dedicated design team are on hand to talk through your requirements.

5 Steps to Your Perfect Solution

Specification	Design	Approval	Manufacture	Support
---------------	--------	----------	-------------	---------



- On site consultation
- Liaise directly with our designers



- Latest solidworks technology
- Stress analysis
- Modern design techniques



- Full rendering of photo realistic imagery
- Customer approval process



- ISO 9001 quality procedures
- Coded welders
- In-house UK manufacturing



- Test certification
- Product rating
- Thorough Examination

If you need a 'be-spoke' solution to your material handling, we'd love to hear from you

Call Us On +44 (0)1686 611 200

Your Peace of Mind

40 Years Experience

With over 40 years experience in the forklift attachment and material handling industry, we have built up an enviable reputation by supplying top quality products to clients worldwide. Manufactured to strict ISO 9001 procedures at our site in Mid Wales, all of our products are designed to meet the rigours of everyday industry – all whilst ensuring real value for money.

Our skilled workforce, innovative design team, and dedicated customer support are all ready and waiting to help with any material handling problem you may have.



Spare Parts

Over time, your attachment may need the occasional spare part, and it's important that you have them available if you need them. We offer a full range of spare parts for all our manufactured products, so if you need to replace that broken spring, or damaged clamp, then we'll get you back up and running with minimal downtime.



Full Testing & Certification

All our products come fully tested and certified in accordance with the Machinery Directive (Directive 2006/42/EC of the European Parliament). We take Health & Safety seriously, and in doing so ensure you're supplied with a product that meets all HSE requirements.



Thorough Examination

Although we'll supply you with a Thorough Examination (Loler) test certificate to cover you for the first 12 months (or 6 months product dependant) from date of supply, as a CFTS accredited company, we can also help you with your Thorough Examination renewal certificates, which, just like a car's MOT, is required on a periodic basis by law.



On-Site Product Training Service

Once you've bought an attachment from us, our service doesn't have to end there. Although every single one of our products come supplied with clear operating instructions, sometimes having a 'hands on' approach can really help, and we'd be delighted to offer you our on-site product training.



Buy with Confidence

Here at Contact Attachments, we have worked with many of the major players in defence, transport and automation, not forgetting the nuclear industries.

We pride ourselves on the quality of our workmanship and our skilled team. With all of our production team fully trained to Coded BSEN standard of welding, you can rest assured that our welding and fabrication is performed to strict controlled conditions and managed by ISO 9001 quality procedures.

“The forklift basket is excellent quality, arrived on time, reasonable cost. What more do you want?”

**Robin Williams,
Site & Service Manager,
Quality Furniture & Co. Ltd**

**Three Year
Contact Attachments
Warranty**

We have so much confidence in the quality of our products that we can offer a 3 year warranty on all of our manufactured attachments.

On top of our 3 year warranty, *all of our attachments also come supplied with our No Quibble Guarantee, which means that if you are not happy with your attachment, then we can replace or offer a 100% refund - no hassle, no complications.

*Custom designed attachments are not included. T&C's apply.

**No Quibble
Guarantee**



Some of Our Satisfied Customers

- Airbus
- American Air Force
- Argos
- BAE Systems PLC
- BBC
- Biffa Group Limited
- BMW
- Bovis Homes
- BP PLC
- British Army
- British Museum
- British Nuclear Fuels Limited
- Britvic PLC
- Castrol
- Caterham Cars
- Chevron Corporation
- Coca Cola
- DHL
- Drax
- Esso
- Etihad Airways
- Eurostar
- GSK (GlaxoSmithKline)
- Gulf Oil
- HM Prison Service
- Honda Motor Co. Ltd
- Johnson Matthey
- LaFarge
- Lotus F1 Team
- Magnox Ltd
- McCain Foods
- McLaren Racing Ltd
- Mercedes AMG Petronas F1 Team
- Mercedes Benz
- Morrisons
- National Health Service (NHS)
- National Trust
- Nato
- Network Rail
- Peugeot
- Procter & Gamble Co.
- Rolls Royce
- Royal Air Force
- Royal National Lifeboat Institution (RNLI)
- Saint Gobain S.A.
- Singapore Airlines
- Stobart Group Ltd
- Superdrug
- Suzuki Motor Corporation
- Tarmac
- The Forestry Commission
- The Royal British Legion
- Thomas Cook Retail Limited
- TNT
- UK Government
- Unipart Rail
- United Nations
- Veolia
- WH Smiths PLC
- Williams Grand Prix Engineering Limited



FM 28306

Contact Attachments Ltd
Unit E, Mochdre Industrial Estate
Newtown
Powys, SY16 4LE
Wales, United Kingdom

Freephone: 0800 028 3332 (UK)
International: +44 (0)1686 611 200
Fax: +44 (0)1686 611 201
sales@forklift-attachments.co.uk