

# ULTRA-MINIATURE LATCHING 2-PORT HIGH DENSITY INTERFACE (HDI) SOLENOID VALVE

The Lee Company's ultra-miniature 2-port solenoid valve is now available in a magnetically latched design and joins Lee's LHL Series of valves under the HDI platform. Optimized for applications that demand ultra-low power, low heat and small size, this magnetically latched solenoid valve is ideal for compact, battery powered devices such as portable respiratory care instruments, breath analyzers, environmental monitors and molecular diagnostic instruments. The valve requires only momentary (10 msec minimum) pulses of current to switch its state resulting in 23 millijoules consumed per switch. The polarity of voltage on the terminal pins controls the switched position.

The Lee Company offers a wide range of standard manifolds for testing as well as custom designed manifold configurations for production. Performance parameters can be optimized for specific applications.

For additional information and technical assistance, please visit our website to contact a local Lee Sales Engineer.

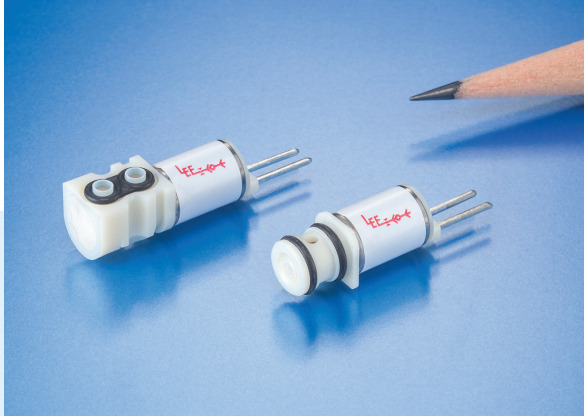

- Magnetically latched
- Ultra-low power and low heat: 23 mJ/switch
- Light weight: less than 2.5 grams
- Ultra-compact size
- Low internal volume
- Operating pressure range: Vac-45 psig (0-10 psid)
- Leakage: less than 50  $\mu$ LPM at 10 psid air, 70°F (21°C)
- Wetted materials: housing (PBT), armature/core (FeCr alloy), spring (316 SS), O-Ring (FKM) and epoxy. See table below for seal and plunger head wetted materials.

STYLE	PART NUMBER	VOLTAGE <sup>1</sup> (Vdc)	LOHM <sup>2</sup> RATE ON AIR AT 70°F (21°C)	WETTED MATERIALS	
				PLUNGER HEAD	SEAL
Plug-In	LHLA0342311H	3.3	1100 Lohms (6 SLPM at 10 psid; Ref Cv = 0.018)	PPS	Silicone
	LHLA0542311H	5			
	LHLA1242311H	12			
	LHLA0542411H	5		PPA	FKM
	LHLA1242411H	12			
Face Mount	LHLA0352311H	3.3		PPS	Silicone
	LHLA0552311H	5			
	LHLA1252311H	12			
	LHLA0552411H	5		PPA	FKM
	LHLA1252411H	12			

NOTES: (1) Other voltages available upon request.  
(2) The Lohm is a measure of flow resistance. Additional information can be found at [www.theleeco.com](http://www.theleeco.com).

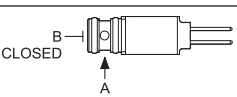
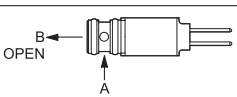
SWITCHING TABLE		
VALVE STATE	TERMINAL	POLARITY
 CLOSED	1	+
	2	-
 OPEN	1	-
	2	+

The valve will switch to, and remain in the state indicated when a 10 to 30 ms electrical pulse is applied with the rated voltage and polarity.

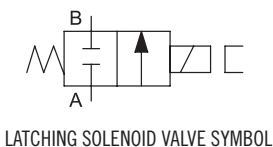

See dimensional drawings on reverse.

## FLOW PERFORMANCE CHARACTERISTICS

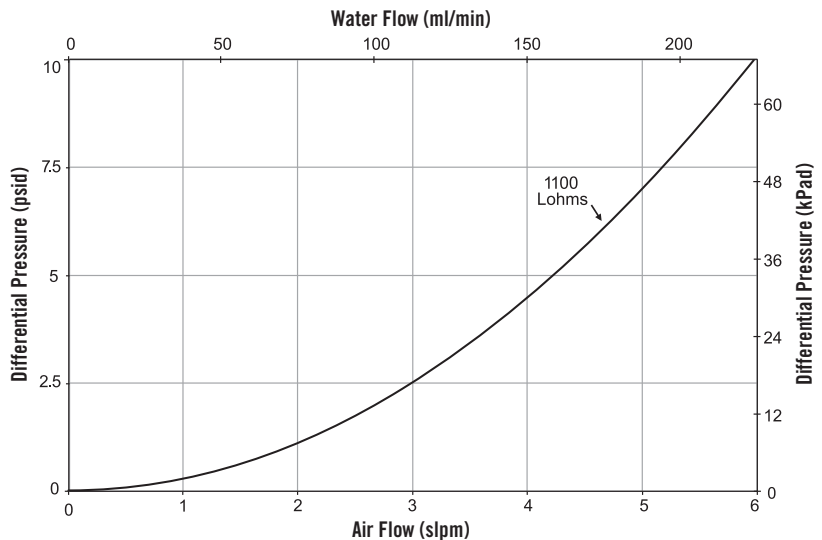

# LATCHING 2-PORT SOLENOID VALVE

## PLUG-IN

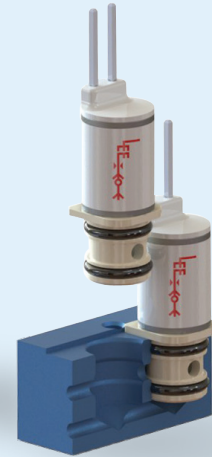
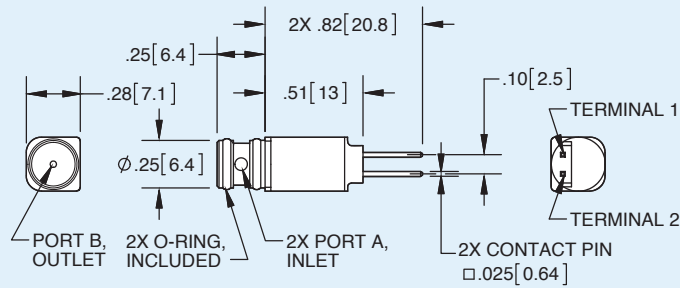

## FACE MOUNT

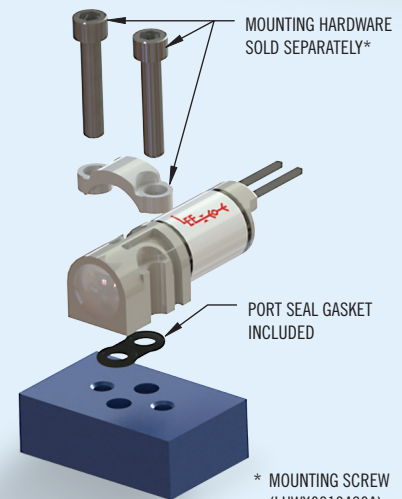
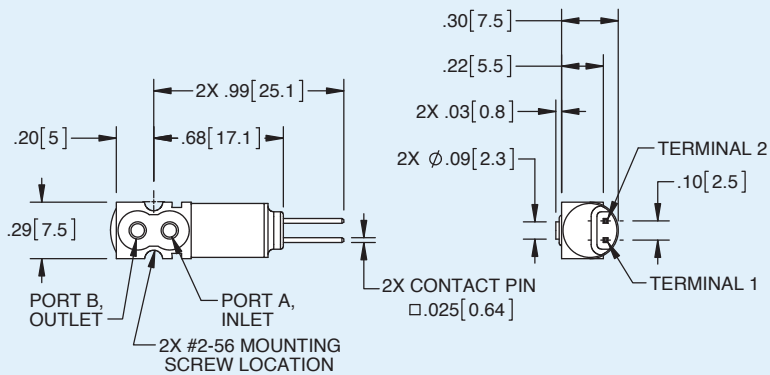

\* MOUNTING SCREW (LHWX0213420A)  
SCREW SUPPORT (LHDX0307140A)

## PLUG-IN BOSS DETAIL

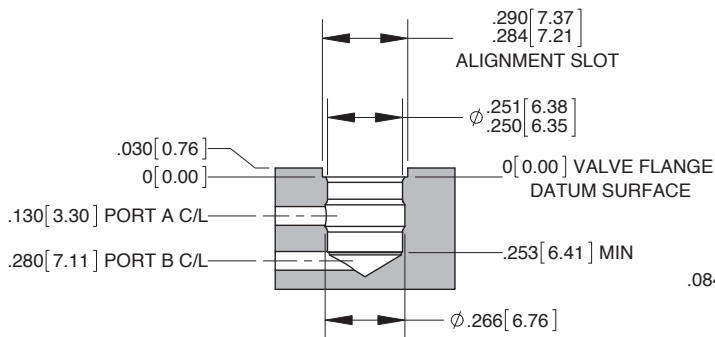

## FACE MOUNT BOSS DETAIL

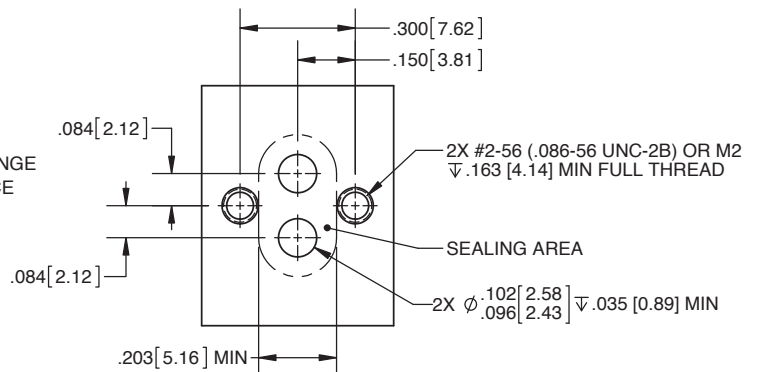

Boss geometries and dimensions shown above are for reference only. All dimensions are in inches [mm].

Reference Drawing Number LCFX0300250B for complete Plug-In Boss specifications and Drawing Number LFIX1002050A for complete Face Mount Boss specifications.

Plug-In Boss geometry may be created using Lee cutting tool Part Number TTTA0000250B.