

## 250 H BENDER JET

Designed to handle demanding system conditions, including high flow rates and large pressure drops, the Lee 250 H Bender Jet restrictor uses a unique metering element that places three orifices in series to help lower fluid velocities and reduce the possibility of cavitation. This multi-orifice design also offers a 40% increase in minimum passage size over a comparable single orifice restrictor, providing an increased resistance to contamination.

Rated for a maximum working pressure differential of 5000 psi, the 250 H Bender Jet is offered in seventeen standard Lohm\* rates, ranging from 600 to 1800 Lohms, and is protected with two integral safety screens for bidirectional flow capability. In addition, each Bender Jet is 100% flow tested to ensure accurate, consistent performance. Special flow rates are available upon request. Contact your Lee Sales Engineer for additional information and technical assistance.

### CROSS-SECTION VIEW

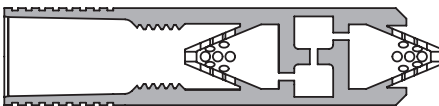

\* The Lohm is a measure of flow resistance. Example: One Lohm will permit a flow of 100 GPM of water at 25 psid at 80°F. Additional information can be found on the back of this sheet or at [www.TheLeeCo.com](http://www.TheLeeCo.com).

# PRODUCT DATA SHEET

- Lohm Rate Tolerance: +/-5%
- 100% Tested  
Bi-directional Flow
- Maximum Working Pressure: 5000 psid
- Nominal Weight: 4.0 grams

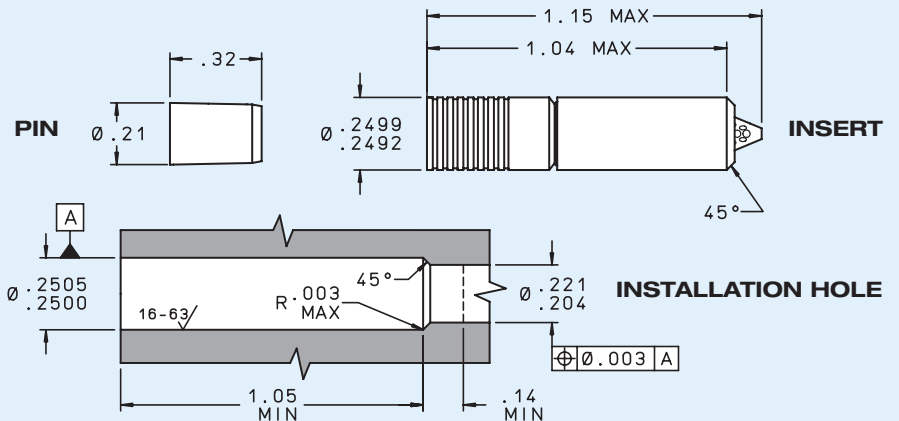

LEE PART NUMBER	LOHM RATE* ±5%	MINIMUM PASSAGE SIZE (Inches)	NOMINAL SCREEN HOLE SIZE (Inches)
JHBA2505600L	600	.050	.024
JHBA2505650L	650	.048	.024
JHBA2505700L	700	.046	.024
JHBA2505750L	750	.044	.024
JHBA2505800L	800	.042	.020
JHBA2505850L	850	.040	.020
JHBA2505900L	900	.039	.020
JHBA2505950L	950	.037	.020
JHBA2505100D	1000	.036	.020
JHBA2505110D	1100	.035	.015
JHBA2505120D	1200	.033	.015
JHBA2505130D	1300	.032	.015
JHBA2505140D	1400	.031	.015
JHBA2505150D	1500	.030	.015
JHBA2505160D	1600	.029	.015
JHBA2505170D	1700	.027	.015
JHBA2505180D	1800	.026	.015

PART	MATERIAL	SPECIFICATION
Locking End	304 CRES	AMS 5639
Pin	17-4 PH CRES	AMS 5643
Metering Element	15-5 PH CRES	AMS 5659
Body	15-5 PH CRES	AMS 5659
Screen	304L CRES	AMS 5647

# LEE LOHM LAWS

## LOHMS LAWS (liquids)

Every engineer will be interested in our simple system of defining the fluid resistance of Lee hydraulic components.

Just as the OHM is used in the electrical industry, we find that we can use a liquid OHM or "Lohm" to good advantage on all hydraulic computations.

When using the Lohm system, you can forget about coefficients of discharge and dimensional tolerances on drilled holes. These factors are automatically compensated for in the Lohm calculations, and confirmed by testing each component to establish flow tolerances. The resistance to flow of any fluid control component can be expressed in Lohms.

The Lohm has been selected so that a 1 Lohm restriction will permit a flow of 100 gallons per minute of water with a pressure drop of 25 psi at a temperature of 80°F.

## LIQUID FLOW FORMULA

The following formulas are presented to extend the use of the Lohm laws to many different liquids, operating over a wide range of pressure conditions.

These formulas introduce compensation factors for liquid density and viscosity. They are applicable to any liquid of known properties, with minimum restrictions on pressure levels or temperature.

The units constant (K) eliminates the need to convert pressure and flow parameters to special units.

$$\text{Volumetric Flow Units } L = \frac{KV}{I} \sqrt{\frac{H}{S}}$$

$$\text{Gravimetric Flow Units } L = \frac{KV}{w} \sqrt{HS}$$

## LIQUID FLOW - UNITS CONSTANT K

VOLUMETRIC FLOW UNITS			
Flow Units	Pressure Units		
	psi	bar	kPa
GPM	20	76.2	7.62
L/min	75.7	288	28.8
ml/min	75 700	288 000	28 800
in <sup>3</sup> /min	4 620	17 600	1 760

GRAVIMETRIC FLOW UNITS			
Flow Units	Pressure Units		
	psi	bar	kPa
PPH	10 000	38 100	3810
gm/min	75 700	288 000	28 800

## NOMENCLATURE

- L = Lohms
- S = Specific gravity\*
- H = Differential pressure
- V = Viscosity compensation factor\*\*
- I = Liquid flow rate: Volumetric
- w = Liquid flow rate: Gravimetric
- K = Units Constant – Liquid (see chart below)
- \*S = 1.0 for water at 80°F.
- \*\*V = 1.0 for water at 80°F.

For other fluids and temperatures, contact your Lee Sales Engineer or visit us at [www.TheLeeCo.com](http://www.TheLeeCo.com)