

281 HIGH PRESSURE DIRECTIONAL FLOW CONTROL

The Lee Company's new 281 High Pressure Directional Flow Control is the latest addition to Lee's line of miniature directional flow control valves. These valves provide restricted flow in one direction and free flow in the other direction. This new valve is ideal for high pressure hydraulic applications with system pressures up to 5000 psi, and incorporates high strength safety screens for both flow directions. Nominal weight is just 6 grams.

Available in forward and reverse free flow configurations, the new Lee 281 High Pressure Directional Flow Control is constructed entirely of stainless steel for durability and long life. Metered Lohm* Rates are available from 1000 to 10,000 Lohms. Maximum free flow restrictions are as low as 175 Lohms. Each directional flow control valve is 100% tested and inspected to ensure reliable, consistent performance.

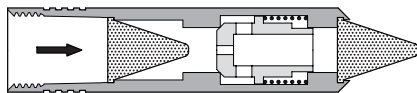

FREE FLOW FORWARD

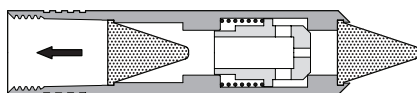

FREE FLOW REVERSE

MATERIALS		
Part	Material	Specification
Body	304 CRES	AMS 5639
Pin	15-5PH CRES	AMS 5659
Poppet	15-5PH CRES	AMS 5659
Spring	17-7PH CRES	AMS 5678
Screens	15-5PH CRES	AMS 5659

PERFORMANCE	
Metered Lohm Rate	Tolerance±5% or ±10%
Nominal System Pressure.....	5000 psid max.
Cracking Pressure	2 - 8 psid

* The Lohm is a measure of flow resistance.

Additional information can be found at www.TheLeeCo.com

- Designed for System Pressures up to 5000 psi
- Weighs only 6 grams
- High Strength Screens Protect both Flow Directions
- 100% Tested and Inspected

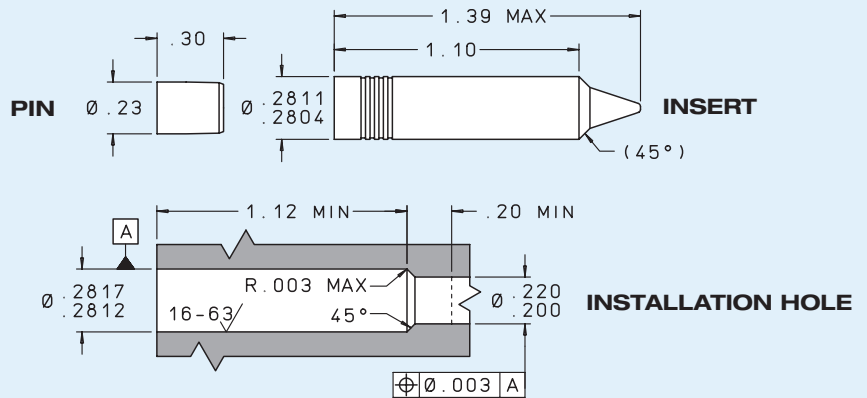

LEE PART NUMBER		METERED* LOHM RATE	FREE FLOW* LOHM RATE (Max.)	NOMINAL SCREEN HOLE SIZE (Inches)
±5%	±10%			
FREE FLOW FORWARD				
FHFA2815100D	FHFA2810100D	1,000	175	0.008
FHFA2815150D	FHFA2810150D	1,500	175	0.008
FHFA2815200D	FHFA2810200D	2,000	175	0.008
FHFA2815250D	FHFA2810250D	2,500	175	0.008
FHFA2815300D	FHFA2810300D	3,000	175	0.008
FHFA2815400D	FHFA2810400D	4,000	175	0.008
FHFA2815500D	FHFA2810500D	5,000	240	0.004
FHFA2815600D	FHFA2810600D	6,000	240	0.004
FHFA2815800D	FHFA2810800D	8,000	240	0.004
FHFA2815100H	FHFA2810100H	10,000	240	0.004
FREE FLOW REVERSE				
FHRA2815100D	FHRA2810100D	1,000	175	0.008
FHRA2815150D	FHRA2810150D	1,500	175	0.008
FHRA2815200D	FHRA2810200D	2,000	175	0.008
FHRA2815250D	FHRA2810250D	2,500	175	0.008
FHRA2815300D	FHRA2810300D	3,000	175	0.008
FHRA2815400D	FHRA2810400D	4,000	175	0.008
FHRA2815500D	FHRA2810500D	5,000	240	0.004
FHRA2815600D	FHRA2810600D	6,000	240	0.004
FHRA2815800D	FHRA2810800D	8,000	240	0.004
FHRA2815100H	FHRA2810100H	10,000	240	0.004

LEE LOHM LAWS

LOHMS LAWS (liquids)

Every engineer will be interested in our simple system of defining the fluid resistance of Lee hydraulic components.

Just as the OHM is used in the electrical industry, we find that we can use a liquid OHM or "Lohm" to good advantage on all hydraulic computations.

When using the Lohm system, you can forget about coefficients of discharge and dimensional tolerances on drilled holes. These factors are automatically compensated for in the Lohm calculations, and confirmed by testing each component to establish flow tolerances. The resistance to flow of any fluid control component can be expressed in Lohms.

The Lohm has been selected so that a 1 Lohm restriction will permit a flow of 100 gallons per minute of water with a pressure drop of 25 psi at a temperature of 80°F.

LIQUID FLOW FORMULA

The following formulas are presented to extend the use of the Lohm laws to many different liquids, operating over a wide range of pressure conditions.

These formulas introduce compensation factors for liquid density and viscosity. They are applicable to any liquid of known properties, with minimum restrictions on pressure levels or temperature.

The units constant (K) eliminates the need to convert pressure and flow parameters to special units.

$$\text{Volumetric Flow Units } L = \frac{KV}{I} \sqrt{\frac{H}{S}} \quad \text{Gravimetric Flow Units } L = \frac{KV}{w} \sqrt{HS}$$

NOMENCLATURE

- L = Lohms
- S = Specific gravity*
- H = Differential pressure
- V = Viscosity compensation factor**
- I = Liquid flow rate: Volumetric
- w = Liquid flow rate: Gravimetric
- K = Units Constant – Liquid (see chart below)
- *S = 1.0 for water at 80°F.
- **V = 1.0 for water at 80°F.

For other fluids and temperatures, contact your Lee Sales Engineer or visit us at www.TheLeeCo.com

LIQUID FLOW - UNITS CONSTANT K

VOLUMETRIC FLOW UNITS			
Flow Units	Pressure Units		
	psi	bar	kPa
GPM	20	76.2	7.62
L/min	75.7	288	28.8
ml/min	75 700	288 000	28 800
in ³ /min	4 620	17 600	1 760

GRAVIMETRIC FLOW UNITS			
Flow Units	Pressure Units		
	psi	bar	kPa
PPH	10 000	38 100	3810
gm/min	75 700	288 000	28 800