

HpE PROCESS

SANITARY CENTRIFUGAL PUMP

OPERATION INSTRUCTION

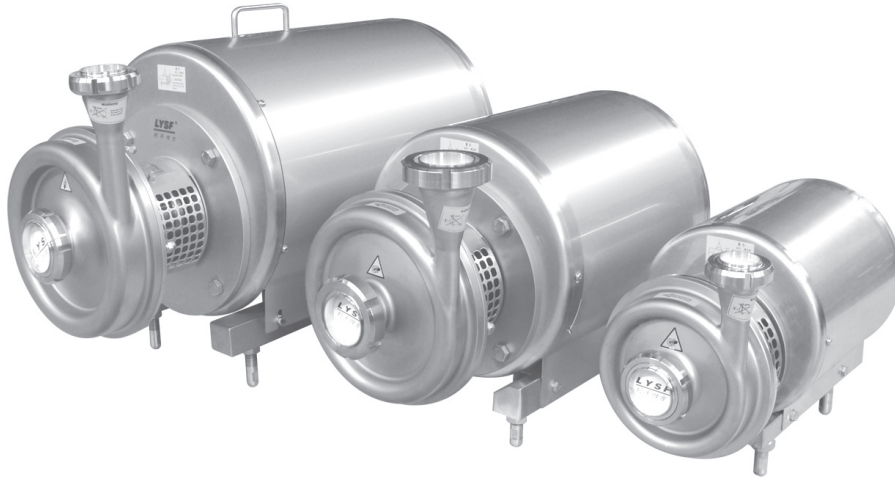

I. Opening Box/Delivery

Pay attention to the following items when opens the box

1. Eliminate the coating material or covering on the inlet and outlet of the pump
2. Check the pump body to see whether it has obvious shipping damage or not
3. Do not damage the inlet and outlet of the pump
4. If the connection of infusion liquid has already been supplied,make sure that is should not be damaged.
5. If the covering is fixed on the pump before the pump is raised,it should be removed first.

Pay attention to the following items when checking and accepting the goods

1. the pump body is complete and undamaged
2. Delivery list
3. The instruction manual of the Pump
4. The instruction manual of the Motor

II. Installation

⚠ It is better to use lifting equipment when installation.

⚠ The pump electric wire should be connected by the professional electrician to ensure correction the motor rotation direction.

Pay attention to the following items when installing

1. The best position while installing the pump is below the inhale liquid(if the pump installing position is above the inhale liquid, it should be infused before turning on the pump)
2. Make sure to have enough space around the pump(not less than 0.5 meter)
3. Make sure that the flow way of inlet and outlet is correct
4. Make sure that the pipeline route is correct
5. Prevent the pump body from the compression(vibration、 pipeline hot inflationt、 much welding、 pipeline overload)

Inspection before opening the pump

⚠ Check pump impeller rotation direction is correct or not(according to the rotation direction label), Reverse operation is forbidden.

⚠ Check the motor cover to prevent the water, damage and electricity.

⚠ Empty running is forbidden , it must have medium and then can be operation.

⚠ If pump with cooling water chamber, first open the cooling water ,then open the pump, the cooling water is bottom input and upper output and its max. pressure is 0.1Mpa.

⚠ Make sure that pipe inside is clean and without any other objects medium before opening the pump.

III. Operating/Controlling

Usage should follow the technical parameters(Page10)

1. When sending hot liquid and sterilizing,touching pump or pipeline should not be allowed in order to prevent burning.
2. When clogging of both inlet and outlet happens,operating the pump should not be allowed in order to prevent exploding.
3. The dry running of the shaft should not be allowed.
4. Installing the pressure regulating valve in the inlet of the pump,throttling in the inlet of pump should not be allowed.
5. Correctly connect the water shaft of the input medium and correctly control the supplying water volume and gas volume.
6. Don't operate overloadedly for a long time,otherwise the motor will be damaged.

IV. Cleaning Method

1. Should be extra careful in treating acid fluid and soda fluid, Shall always wear the rubber gloves and protective glass.
2. Touching the pump or tubings is absolutely not allowed to avoid hurt by burning while disinfecting
3. Examples of cleaning fluid composition.
 - 1) At 70°C, 1% NaOH: NaOH(1kg)+Water(100L)=Cleaning Fluid
 - 2) At 70°C, 0.3% HNO₃: 53% HNO₃(0.7L)+Water(100L)=Cleaning Fluid
4. Cleaning Fluid Composition and Usage:
 - 1) While mixing, all the solutions shall be put in step by step to avoid high concentration
 - 2) To adjust the flow volume during the process (Like milk, viscosity fluid etc, should increase the flow volume)

Attention:

1. After the cleaning, the fluid should be washed out completely by clean water
2. The storage and usage of cleaning water shall comply with the present regulation / instruction strictly

V. Maintenance

1. Must follow technical parameters (Page 10)
2. When repairing, should first cut off the power
3. While repairing, do not heat the pump body
4. While repairing, any pressure inside the pump and tubing is forbidden
5. After repairing or maintenance, if the power wires have been taken off the motor, be sure that they are correctly connected as well.

General Repair



Item	Shaft Seal	Rubber Gasket	Motor Shaft
Maintenance	Replace all the shaft seal in 12 month (1 shaft working time)	Replace with shaft seal	
Repair after leakage (leakage starts slowly)	Replace all the seals right away	Replace with shaft seal	
Planned Repair	<ol style="list-style-type: none"> 1. Inspection running and leakage on time 2. Record inspection report 3. Arrange inspection acc to record statistics 4. Replace all shaft seals after leakage 	Replace with shaft seal	<ol style="list-style-type: none"> 1. Suggest annual inspection 2. Replace all the shaft in case they wear out 3. Shaft axially locked
Lubrication	Before installation: Lubricate the O-ring with Silicone oil or grease	Before installation: Lubricate with Silicone oil or grease	Long-term lubrication

VI. Eliminating Trouble

Pump trouble	The reason caused the trouble	Preventive measure and removing way
Motor exceeds load	<ol style="list-style-type: none"> 1. The viscosity of material conveyed by pump is too high 2. The pressure of exit is too low 3. Sediment gathers in the liquid 	<ol style="list-style-type: none"> 1. Changing a bigger motor or smaller impeller 2. Increasing backpressure(throttling) 3. Washing frequently
high quake or noise	<ol style="list-style-type: none"> 1. Foot screws are too looseness and have different height 2. Principal axis jumpiness 	<ol style="list-style-type: none"> 1. Adjusting the height,leaving the floor placidly and screwing down the screw cap 2. Changing the principal axis
Unstable electric	<ol style="list-style-type: none"> 1. Unstable Voltage,uneven three phase voltage 	<ol style="list-style-type: none"> 1. Checking voltage and adopting the measure of leveling off voltage
The leakage of the casing pump casing flange gasket	<ol style="list-style-type: none"> 1. Gasket is not in the groove 2. The casing pump flange screw is not fastened 	<ol style="list-style-type: none"> 1. Taking apart the pump head and letting the gasket in the seal canal 2. fastening six screws
The leakage of pump mechanical seal	<ol style="list-style-type: none"> 1. Metal sundries particle enters the surface of the seal and damages the seal of the machine 2. Static ring is not in the pin key of the impeller pedestal,O-ring is not screwed down 3. Before turning on the pump,there is no liquid,the time of racing and reversal is too long,so that seal face is burned out 4. The spring rotating ring is damaged and dropped.The seal has no pressure,before turning on,haven't rotated the principal axis,the surface of seal conglutinates tightly 	<ol style="list-style-type: none"> 1. Before turning on,checking the pump head,purging and changing the mechanical seal 2. Taking apart and letting the static ring in the pin key,impacting into the O-ring. 3. Turning on then turning off,and seeing that if the rotary direction is the same with the rotary direction of the pump,changing the mechanical seal. 4. Before turning on,rotate the principal axis for several times,opening and checking the seal if too tightly,and changing the seal spring or a complete set of seal.
leakage after changing the new seal	The way of change is wrong	<p>Taking apart the chassis,purging every step,blowing the seal static ring cleanly then putting it in the seal canal of,impeller seat,please note that static ring should aim at the pin key,wiping the principal axis cleanly,installing rotating ring,screwing down the yoke screw,then installing the impeller and casing pump.</p>

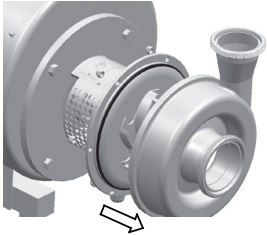
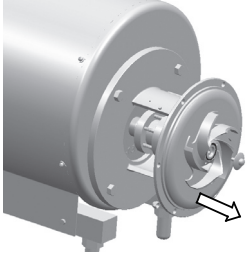
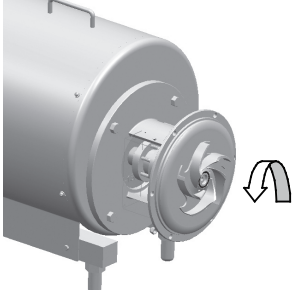
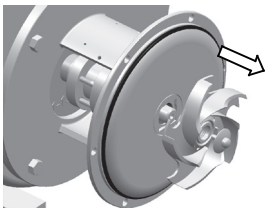
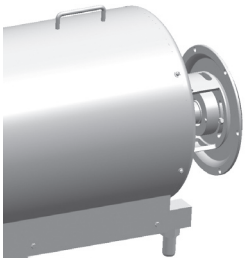
Pump Disassembly

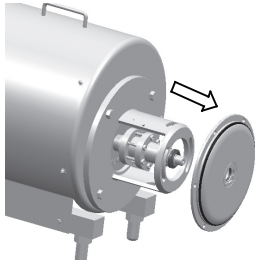
	<p>Screwing off the cap nut(11),taking down spring pad(10)、 pad(9)and casing pump(1).</p>
	<ol style="list-style-type: none"> 1. Screwing off the cup socket(2) 2. Taking down the O-ring from the impeller(3) 3. Taking down the impeller(4), if necessary,knocking the impeller blade lightly to get rid of the impeller
	
	
	<p>Impeller seat</p> <ol style="list-style-type: none"> 1. Screwing off the inlet and outlet of the water injection string(30)

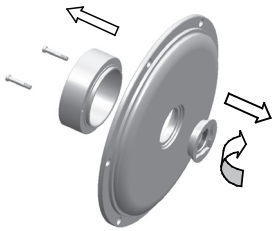
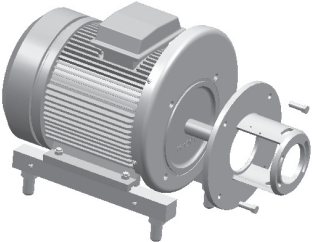
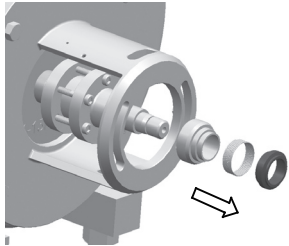
	<p>2. Screwing off the nut(26),taking down spring pad(25)、 pad(24)、 and impeller seat(8).</p> <p>3. Taking down the O–ring from the impeller seat.(7).</p>
	
	<p>1. Using the special tool to screw off the static ring(5)and O–ring(6)</p> <p>2. Screwing off the bolt(32),taking down the mechanical seal seat.(31)</p>
	<p>Screwing off the nut(41),taking down the pad(39)、 bolt(27)and bracket(23)</p>
	<p style="text-align: center;">Mechanical seal</p> <p>1. Screwing off the screw(22),taking down the Shield(21).</p> <p>2. Taking down the rotating ring(15)from the spring(14).</p> <p>3. Taking down the spring(14)from the drive collar.</p> <p>4. Taking down the drive collar and O–ring(12).</p>

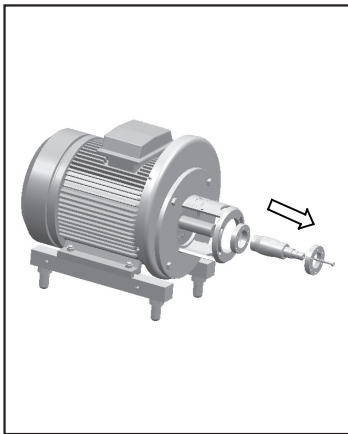

Principal axis

1. Loosing the bolt(16),taking the principal axis (19) and the retaining collar (18). Knocking the coupler 2(17) lightly to get rid of the principal axis.
2. Screwing off the bolt,taking down the coupler 2 and the coupler 1(20)from the principal axis.

Adjusting the axis

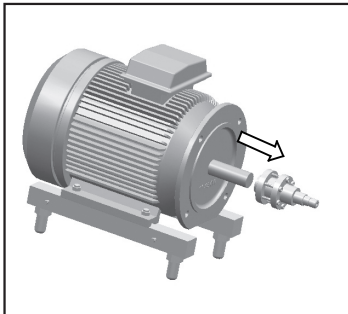

Note:adjusting the axis should refer to the decomposition pictures of the sanitary centrifugal pump

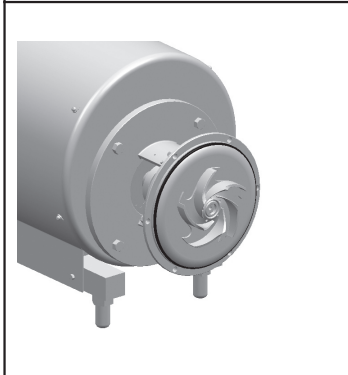
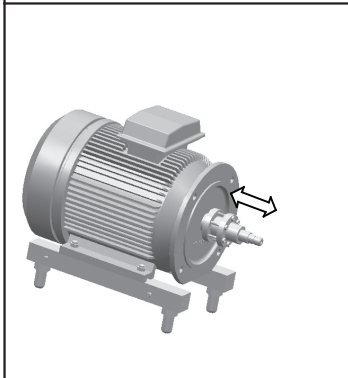

1. Loosing screw(16),pulling the principal axis(19)and coupler(17、 20)
2. Pushing the principal axis and the coupler in the motor shaft,checking and making sure that the distance between principal axis port and motor flange is 10~20mm.
3. Fastening the screw(16)lightly and proportionally,making sure that principal axis can move to the motor shaft.
4. Installing the impeller seat(8),pad(24),spring pad(25)and nut(26),letting them fasten also.
5. Installing the impeller in the principal axis 7,adjusting the distance between impeller(4)and impeller seat is 0.5mm.
6. Taking down the impeller and impeller seat,fastening screw(16)proportionally.

X. Technical Data

Max.inlet pressure:0.5Mpa

Temperature range:-10℃ to + 140℃
(EPDM)

Noise level(at 1 m):60-80dB(A)

Shaft seal

1. Seal type: Single end mechanical seal ,
Single end mechanical seal with cooling
water chamber,Double ends mechanical
seal
2. Max.water pressure: seal with cooling
water chamber (Max.0.1Mpa)
Double ends mechanical seal(
Max.0.5Mpa)
3. Water consumption: seal with cooling
water chamber (0.25-0.5L/min)
Double ends mechanical seal(0.25-0.5L/
min)

Materials

1. Product wetted steel parts:SUS316L or
SUS304 stainless steel
2. Other steel parts:SUS304 stainless steel
3. Auxiliary sealed material:
NBR,EPDM,VMQ,FKM,PTFE
4. Machinery sealed material:C-SIC
SIC-SIC

Motor

1. These motors are made from ABB brand
Standard three phase AC machine.
They are built to comply with current
international standards:International
Electro-technical Commission IEC60034
and IEC60072,EU directives to fulfill
European"CE"marking.
2. Superior electric performance,low
noise,low quake,All motors are protected
to IP55 as a minimum,Insulation level for
the motors is F level.
3. Specified voltage and frequency
3~,50Hz,220~240V/380~420V/660~690
V,Δ/Y
4. Power
0.55、0.75、1.1、1.5、2.2、3、4、5.5、7.5、11、
15、18.5、22、30、45、55KW
5. Speed of rotation
The speed of rotation for standard pump
is 2900rpm

Surface treatment

Product wetted part:bright 0.4μm,other
parts:sandblasting or semi bright

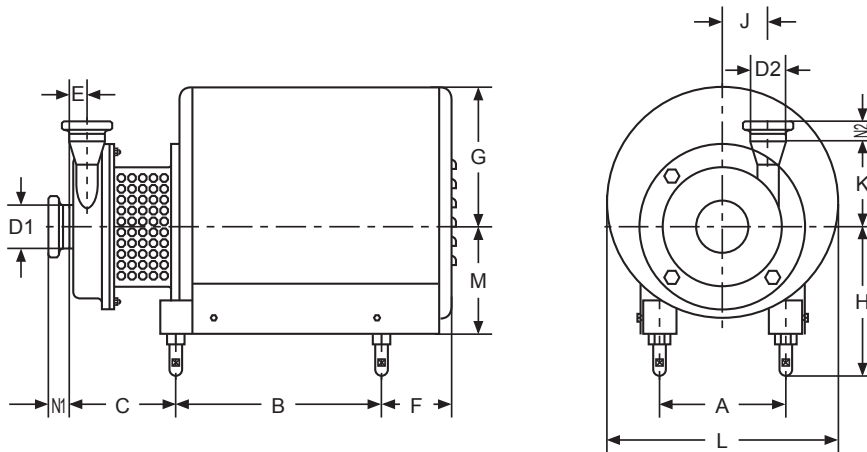

Size	Motor Power	A	B	C	E	F	G	H _{max}	H _{min}	J	K	L	M
SFB-5	0.55KW	112	215	103	22	46	110	170	140	49	90	240	80
	0.75KW	125	224	125	22	100	200	190	160	88	145	278	120
	1.1KW	125	224	125	22	100	200	190	160	88	145	278	120
	1.5KW	145	224	155	22	116	165	190	160	88	145	278	120
	2.2KW	145	224	155	22	116	165	190	160	88	145	278	120
SFB-10	1.5KW	145	224	155	23	116	165	190	160	88	145	278	120
	2.2KW	145	224	155	23	116	165	190	160	88	145	278	120
	3KW	170	269	148	23	116	210	240	210	88	145	348	140
	4KW	190	269	155	23	116	210	240	210	88	145	348	152
SFB-15	3KW	170	269	148	43	116	210	240	210	88	145	348	140
	4KW	190	269	155	43	116	210	240	210	88	145	348	152
	5.5KW	216	328	176	43	160	215	260	230	88	145	378	182
SFB-20	3KW	170	269	148	27	116	210	240	210	88	145	348	140
	4KW	190	269	155	27	116	210	240	210	88	145	348	152
	5.5KW	216	328	176	27	160	215	260	230	88	145	378	182
	7.5KW	216	328	176	27	160	215	260	230	88	145	378	182
SFB-25	4KW	190	269	155	32	116	210	240	210	88	145	348	152
	5.5KW	216	328	176	32	160	215	260	230	88	145	378	182
	7.5KW	216	328	176	32	160	215	260	230	88	145	378	182
	11KW	254	400	232	32	188	270	300	260	117	194	453	210
	15KW	254	400	232	32	188	270	300	260	117	194	453	210

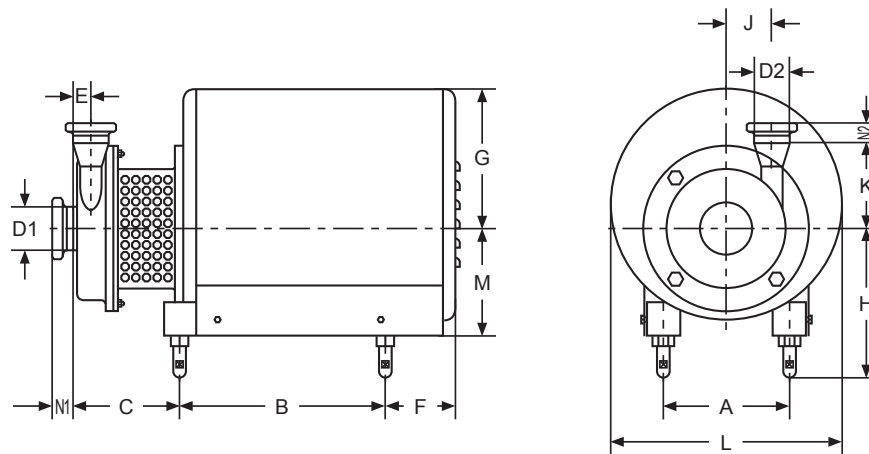

Size	Motor Power	A	B	C	E	F	G	H _{max}	H _{min}	J	K	L	M
SFB-35	4KW	190	269	155	23	116	210	240	210	88	145	348	152
	5.5KW	216	328	176	23	160	215	260	230	88	145	378	182
	7.5KW	216	328	176	23	160	215	260	230	88	145	378	182
	11KW	254	400	232	23	188	270	300	260	117	194	453	210
	15KW	254	400	232	23	188	270	300	260	117	194	453	210
SFB-40	7.5KW	216	328	176	28	160	215	260	230	88	145	378	182
	11KW	254	400	232	28	188	270	300	260	117	194	453	210
	15KW	254	400	232	28	188	270	300	260	117	194	453	210
	18.5KW	254	400	232	28	188	270	300	260	117	194	453	210
	22KW	279	390	250	28	200	285	320	280	117	194	470	230
SFB-45	4KW	190	269	155	41	116	210	240	210	88	145	348	152
	5.5/7.5KW	216	330	183	41	160	263	282	232	117	194	360	182
	11/15/18.5KW	254	440	215	41	175	310	310	260	117	194	410	210
SFB-60	5.5/7.5KW	216	330	183	62	160	263	282	232	117	194	360	182
	11/15/18.5KW	254	440	215	62	175	310	310	260	117	194	410	210
	22KW	279	390	250	62	200	285	320	280	117	194	470	230
	30KW	318	480	250	62	200	350	370	330	117	194	560	260
SFB-70	18.5KW	254	400	232	25	188	270	300	260	117	194	453	210
	22KW	279	390	250	25	200	285	320	280	117	194	470	230
	30KW	318	480	250	25	200	350	370	330	117	194	560	260
	45KW	356	510	300	25	300	364	400	360	140	255	600	285
	55KW	406	604	315	25	300	405	400	360	140	255	690	310

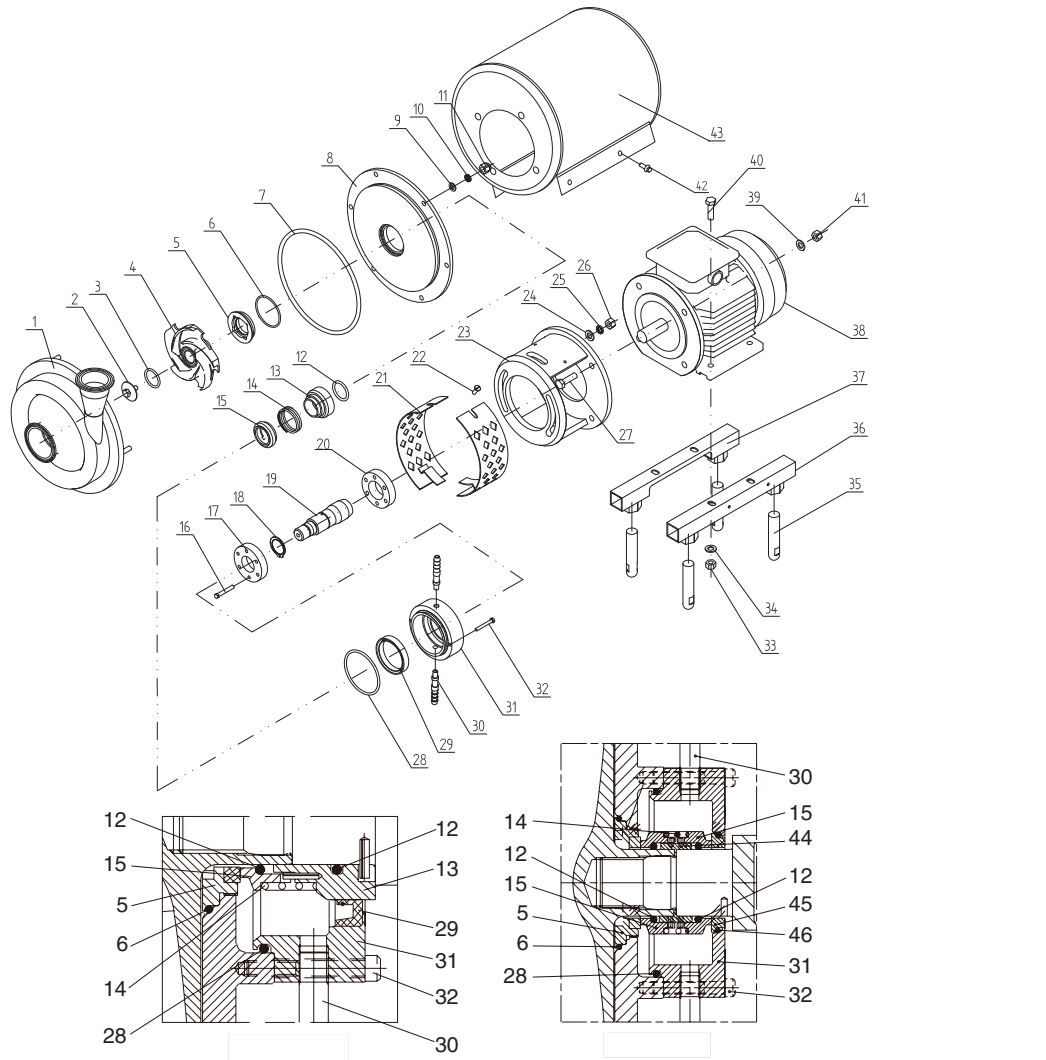

- | | | | | | |
|----------------|-------------------|----------------------|--------------------------|-------------------|--------------------------|
| 1、 Pump casing | 9、 Pad | 17、 Coupler(2) | 25、 Spring pad | 33、 Nut | 41、 Nut |
| 2、 Cup socket | 10、 Spring pad | 18、 Retaining collar | 26、 Nut | 34、 Pad | 42、 Flange screw |
| 3、 O-ring | 11、 Cap nut | 19、 Principal axis | 27、 Bolt | 35、 Stand | 43、 Motor Cover |
| 4、 Impeller | 12、 O-ring | 20、 Coupler(1) | 28、 O-ring | 36、 Motor stand 1 | 44、 Drive ring |
| 5、 Static ring | 13、 Drive collar | 21、 Shield | 29、 Lip seal | 37、 Motor stand 2 | 45、 Stationary Seal ring |
| 6、 O-ring | 14、 Spring | 22、 Screw | 30、 Inlet and outlet | 38、 Motor | 46、 O-ring |
| 7、 O-ring | 15、 Rotating ring | 23、 Bracket | 31、 Mechanical seal seat | 39、 Pad | |
| 8、 Back Plate | 16、 Screw | 24、 Pad | 32、 Screw | 40、 Bolt | |

SEPARATE PARTS OF THE SANITARY CENTRIFUGAL PUMP