

TECHNIFLOW 



New Range

# FUMAGALLI HI-TECH



 **Fumagalli Componenti**

PARIS | LONDON | NEW YORK | WIEN | MILAN | ROME | VENICE

[www.fumagallidryers.com](http://www.fumagallidryers.com)



## ECOLOGICAL WARM AIR HAND DRYER FOR ENERGY SAVINGS



**FM09 A**

**FM09 A (b)**

### FUMAGALLI HI-TECH

4th generation hand dryer

Hand dryer featuring a new technology: it offers improved performances, pleasant drying and the possibility of personalized regulation of main parameters. Further benefit is reduction of energy consumption and maintenance costs.

Eco-friendly and 98% recyclable, it is totally renewable thanks to the new patented "LEM" system.

New exclusive and deluxe finishings from Collection range enrich the dryer design.

White enamelled finishing with antimicrobial treatment (silver ions)

### Available finishings

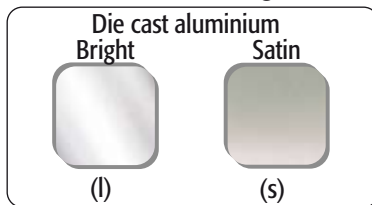

### Range *Collection* (special finishings)

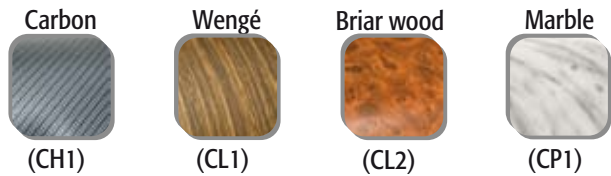

**Fast drying**  
Reduction of drying time\*



**Savings**  
Reduction of energy and maintenance\*



**Eco-Life-Program**  
Easily renewable for longer life



**LEM System**  
Long Life Easy Maintenance (patented system)



**New motor**  
With thermal protection

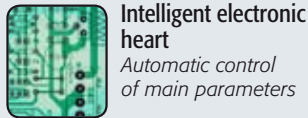

**Intelligent electronic heart**  
Automatic control of main parameters



**Temperature Adjustable**



**Made in Italy**  
Italian design and technology

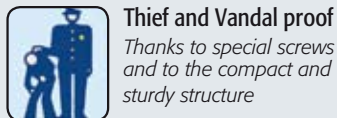

**Thief and Vandal proof**  
Thanks to special screws and to the compact and sturdy structure



**Test certificate**  
Every dryer is supplied with test certificate



**Eco friendly**  
Totally recyclable

\* Compared to traditional dryers

### Technical details

### Dimensions

Functioning	Photocell
Body material	Die cast aluminium
Net weight	4,8 kg
Supply voltage	220/240 V
Main frequency	50/60 Hz
Absorption	From 750 W to 2450 W
Air temperature	Adjustable
Ingress protection level	IP23
Electrical protection level	Class I

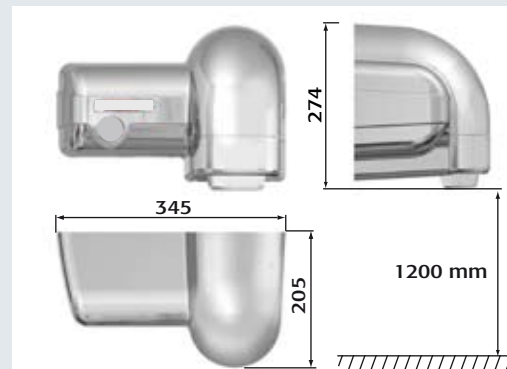

Fumagalli Componenti reserves the right to modify the products without notice.  
Reproduction of photos and/or logos without authorisation is illegal and strictly prohibited.  
For special options ask for specific offer conditions.

Tested quality