

*Sovereign*





# Downlights



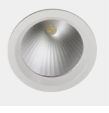
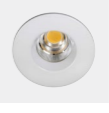

The signature range from  
Commercial Lighting Systems Ltd

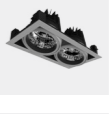
# Index

	<b>Maxi</b> <i>Fixed Downlight</i>	8
	<b>Midi</b> <i>Fixed Downlight</i>	10
	<b>Mini</b> <i>Fixed Downlight</i>	12
	<b>Mini Darklight</b> <i>Fixed Downlight</i>	14
	<b>Maxi</b> <i>Gimbal Downlight</i>	20
	<b>Maxi Twin</b> <i>Gimbal Downlight</i>	22
	<b>Midi</b> <i>Gimbal Downlight</i>	24
	<b>Scoop</b> <i>Adjustable Downlight</i>	26



# Versatile

The Sovereign Downlight catalogue offers a comprehensive range of ceiling downlights. Each product range is highly customisable to meet exact requirements. Standard variants are shown, but many more options are available, including bespoke customisation. Please get in touch for more details.

# High Quality

Sovereign products are built to last. We use only the highest quality materials and trusted suppliers. This ensures premium light quality and product longevity.





A comprehensive range of interior ceiling downlights. From miniature 2W display downlights to high power luminaires for suitable for large indoor spaces.

Perfect for new installations or as an ideal replacement for existing metal halide units.

*the*  
**Fixed  
Downlight**  
*ranges*





Product Family	Housing Colour	CCT	Suffix
S98911 20W	.05 White	01 3000K	.8
S98912 25W	.04 Black	02 4000K	
S98913 30W	.21 Silver		
S98914 35W			

EM and dimmable options available - see page 30 for ordering info.

# Maxi Fixed

## Interior Downlight

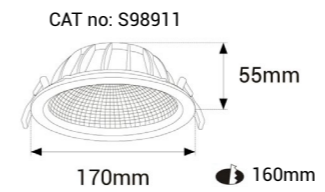

Wattage	CCT	Lumens	Efficacy
20W	3000K	2000lm	100lm/W
20W	4000K	2200lm	110lm/W

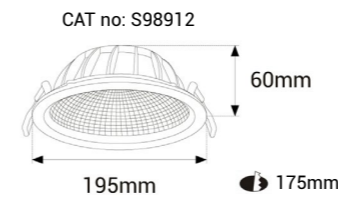

Wattage	CCT	Lumens	Efficacy
25W	3000K	2500lm	100lm/W
25W	4000K	2750lm	110lm/W

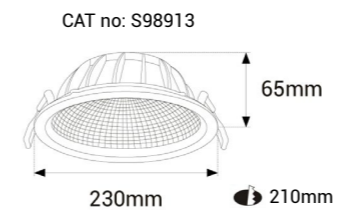

Wattage	CCT	Lumens	Efficacy
30W	3000K	3000lm	100lm/W
30W	4000K	3300lm	110lm/W

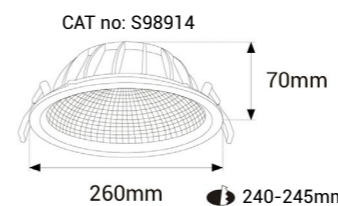

Wattage	CCT	Lumens	Efficacy
35W	3000K	2500lm	100lm/W
35W	4000K	3850lm	110lm/W

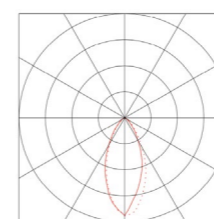

### TECHNICAL SPECIFICATIONS

IP rating	IP20
CRI	>80
Lamp Life	50,000 hours
Light Source	CREE LED
Voltage	240V
Driver	High efficiency
LED Warranty	5 Years

### HOUSING

Material	Aluminium
Finish	Powder coated
Protection Rating	Class 1
Optics	Clear Glass
Weight	1.4kg
Mounting	Ceiling recessed

Offering impressive lumen packages with exceptional LOR, the Maxi Fixed units are an ideal replacement for metal halide and compact fluorescent downlights.

Available in four sizes and outputs, as well as our usual customisation options including EM and dimmable control.

### Maxi Fixed



Ceiling Downlights



Product Family	Bezel Colour	CCT & Output	Suffix
S18154 Standard	.05 White	07 3000K 12.62W	.8
S18174 Drop glass	.04 Black	08 4000K 12.62W	
S18254 Under canopy	.21 Silver	02 3000K 18.42W	
		03 4000K 18.42W	
		04 3000K 26.44W	
		05 4000K 26.44W	
		33 3000K 34.34W	
		34 4000K 34.34W	

EM and dimmable options available - see page 30 for ordering info.

# Midi Fixed

Interior Downlight

## LIGHT DETAILS

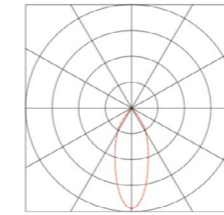

Wattage	CCT	Lumens	Efficacy
12.62W	3000K	1932lm	153lm/W
12.62W	4000K	1987lm	157lm/W
18.42W	3000K	2740lm	149lm/W
18.42W	4000K	2836lm	154lm/W
26.44W	3000K	3726lm	141lm/W
26.44W	4000K	3833lm	145lm/W
34.34W	3000K	4941lm	144lm/W
34.34W	4000K	5152lm	150lm/W

One of our most successful UK produced downlights, the Sovereign MIDI Fixed Downlight is a powerful luminaire capable of over 5000lm with impressive efficiency.

Available in different housing styles to suit a range of applications, the Midi Fixed is offered with four different outputs as well as our usual customisable options.

## DIMENSIONS

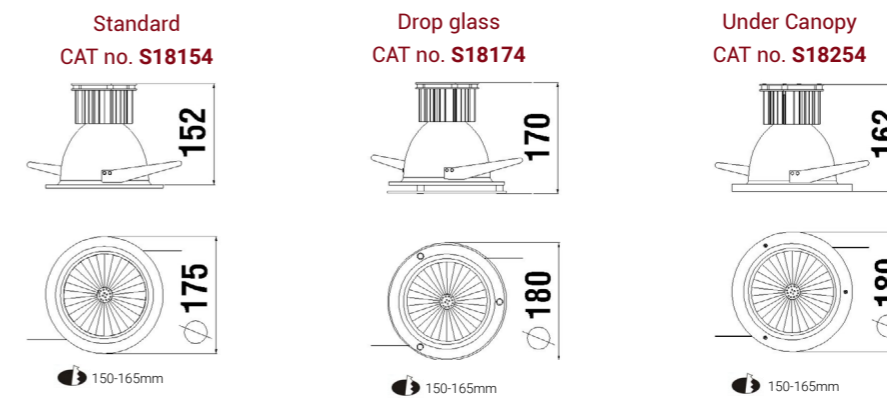

## TECHNICAL SPECIFICATIONS

IP rating	IP40
CRI	>80
Lamp Life	50,000 hours
Light Source	Tridonic SLE G7
Voltage	240V
Driver	High efficiency
LED Warranty	5 Years

## HOUSING

Material	Aluminium
Finish	Powder coated
Protection Rating	Class 1
Weight	0.85kg
Mounting	Ceiling Recessed

## Midi Fixed



Ceiling Downlights





darklight option

standard / under canopy / drop glass



Product Family	Insert	Beam	Bezel Colour	CCT	Suffix
<b>S18153</b> Standard	<b>D</b> Darklight	<b>SP</b> Spot	<b>.05</b> White	<b>00</b> 3000K	<b>.8</b>
<b>S18173</b> Drop glass	Standard	<b>FL</b> Flood	<b>.04</b> Black	<b>08</b> 4000K	
<b>S18253</b> Under canopy		<b>WFL</b> Wide Flood	<b>.21</b> Silver		

EM and dimmable options available - see page 30 for ordering info.

# Mini Fixed

Interior Downlight

## LIGHT DETAILS

Wattage	CCT	Lumens	Efficacy
9.4W	3000K	1346lm	143lm/W
9.4W	4000K	1423lm	151lm/W

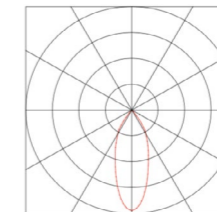

A high quality miniature LED downlight designed and produced in the UK as a realistic replacement for existing MR16 Halogen units. Incorporating the latest Tridonic LES10 LED array, this is an exceptionally efficient LED, providing up to a genuine 151lm/W including driver losses.

Includes passive heat-sink technology, built-in clear lens for glare reduction, a high performance faceted reflector, and a number of customisable options.

## DIMENSIONS

Standard  
CAT no. **S18153**

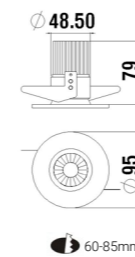

Under Canopy  
CAT no. **S18253**

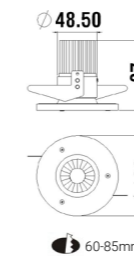

Drop glass  
CAT no. **S18173**

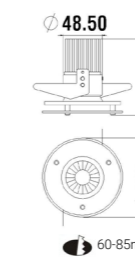

Darklight

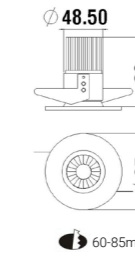

## TECHNICAL SPECIFICATIONS

IP rating	IP40
CRI	>80
Lamp Life	50,000 hours
Light Source	Tridonic SLE LED
Voltage	240V
Driver	High efficiency
Beam	15° / 25° / 45°
LED Warranty	5 Years

## HOUSING

Material	Aluminium
Finish	Powder coated
Protection Rating	Class 1
Optics	Clear acrylic
Weight	0.38kg
Mounting	Ceiling recessed

## Mini Fixed



Ceiling Downlights

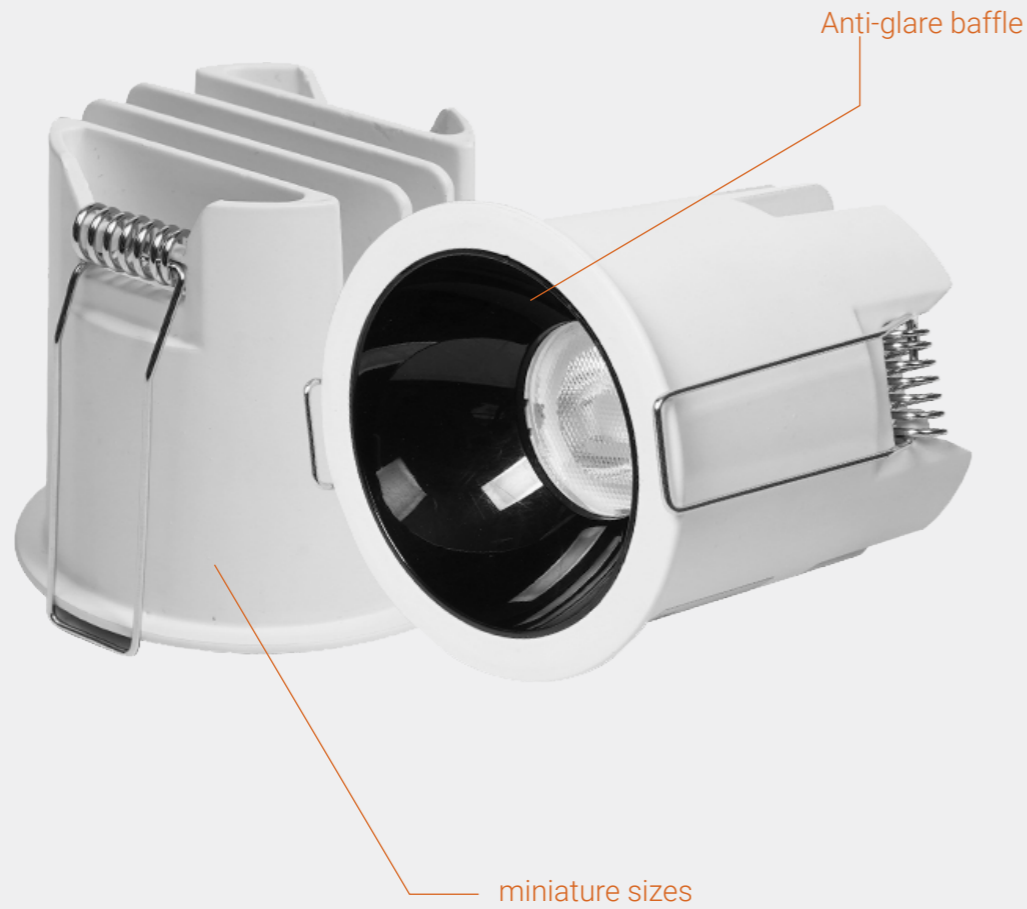

Product Family	Beam	Bezel Colour	CCT	Suffix
S18120 2W	SP Spot	.05 White	10 2700K	.8
S18121 3W	FL Flood	.04 Black	11 3000K	
S18122 5W	WFL Wide Flood	.21 Silver	12 4000K	
S18123 8W				
S18124 12W				

EM and dimmable options available - see page 30 for ordering info.

# Mini Darklight

Display Downlight

CAT no. S18120

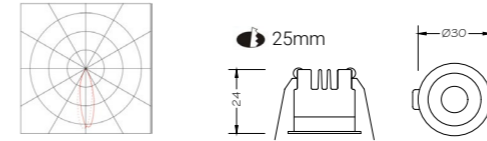

CAT no. S18121

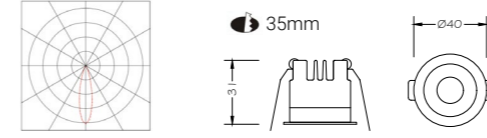

CAT no. S18122

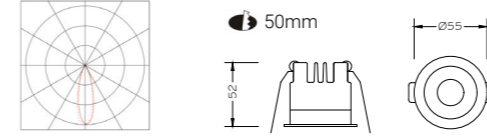

CAT no. S18123

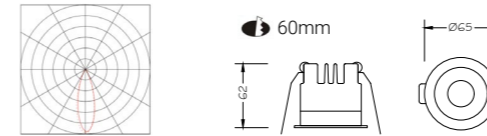

CAT no. S18124

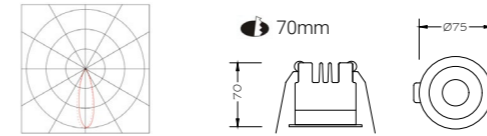

## LIGHT DETAILS

Wattage	CCT	Lumens	Efficacy
2W	3000K	210lm	105lm/W
2W	4000K	220lm	110lm/W

Wattage	CCT	Lumens	Efficacy
3W	3000K	315lm	105lm/W
3W	4000K	330lm	110lm/W

Wattage	CCT	Lumens	Efficacy
5W	3000K	525lm	105lm/W
5W	4000K	550lm	110lm/W

Wattage	CCT	Lumens	Efficacy
8W	3000K	840lm	105lm/W
8W	4000K	880lm	110lm/W

Wattage	CCT	Lumens	Efficacy
12W	3000K	1260lm	105lm/W
12W	4000K	1320lm	110lm/W

The Sovereign Mini Darklight is a range of high quality fixed LED downlights with built in anti-glare baffle to provide a high level of comfort and efficiency.

All versions supplied complete with carefully matched remote drivers designed to pass through the cut-out, even on the tiny 2W version with its 25mm diameter (one of the smallest downlights on the market).

Simple plug & socket system between driver and head for ease of installation.

## TECHNICAL SPECIFICATIONS

IP rating	IP40
CRI	>80
Lamp Life	50,000 hours
Light Source	CREE COB
Voltage	240V
Driver	High efficiency
LED Warranty	5 Years

## HOUSING

Material	Aluminium
Finish	Powder coated
Protection Rating	Class 1
Optics	Anti glare baffle
Weight	0.2kg
Mounting	Ceiling Recessed

## Mini Darklight



Ceiling Downlights







*the*  
**Adjustable  
Downlight**  
*ranges*

For applications requiring variable beam angles, such as for wall displays. Ideal for retail, hospitality and office environments.





Product Family		Beam		Bezel Colour		CCT & Output		Suffix
S18151	20W	SP	Spot	.05	White	10	3000K 20W	.8
S18155	28W	FL	Flood	.04	Black	11	4000K 20W	
		WFL	Wide Flood	.21	Silver	02	3000K 28W	
						03	4000K 28W	

EM and dimmable options available - see page 30 for ordering info.

# Maxi Gimbal

Interior Downlight

## LIGHT DETAILS

Wattage	CCT	Lumens	Efficacy
20W	3000K	2179lm	108lm/W
20W	4000K	2311lm	115lm/W
28W	3000K	2959lm	106lm/W
28W	4000K	3137lm	112lm/W

## PHOTOMETRY

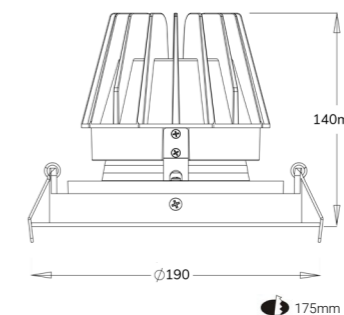
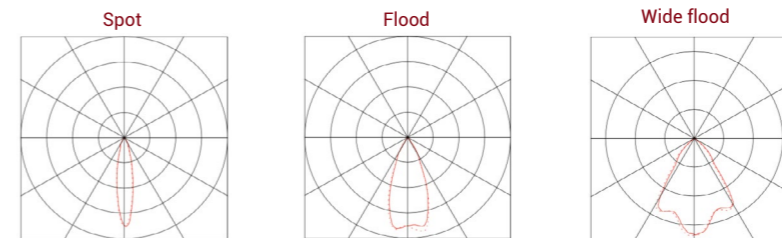

## TECHNICAL SPECIFICATIONS

IP rating	IP40
CRI	>90
Lamp Life	50,000 hours
Light Source	Osram PL-Core
Tilt	30°
Voltage	240V
Driver	High efficiency
Beam	Spot / Flood / Wide Flood
LED Warranty	5 Years

## HOUSING

Material	Aluminium
Finish	Powder coated
Protection Rating	Class 1
Optics	Clear glass
Weight	0.6kg
Mounting	Ceiling recessed

The Sovereign Maxi Gimbal Downlight pairs an impressive light output with the flexibility of a gimbal fixture. Ideal for retail applications.

Incorporating the latest Osram PL-CORE LED modules which are coupled with a high efficiency, low flicker LED driver for optimum life and efficiency.

Fixed output drivers are supplied as standard but dimmable options are available to suit any dimming protocol.

## Maxi Gimbal



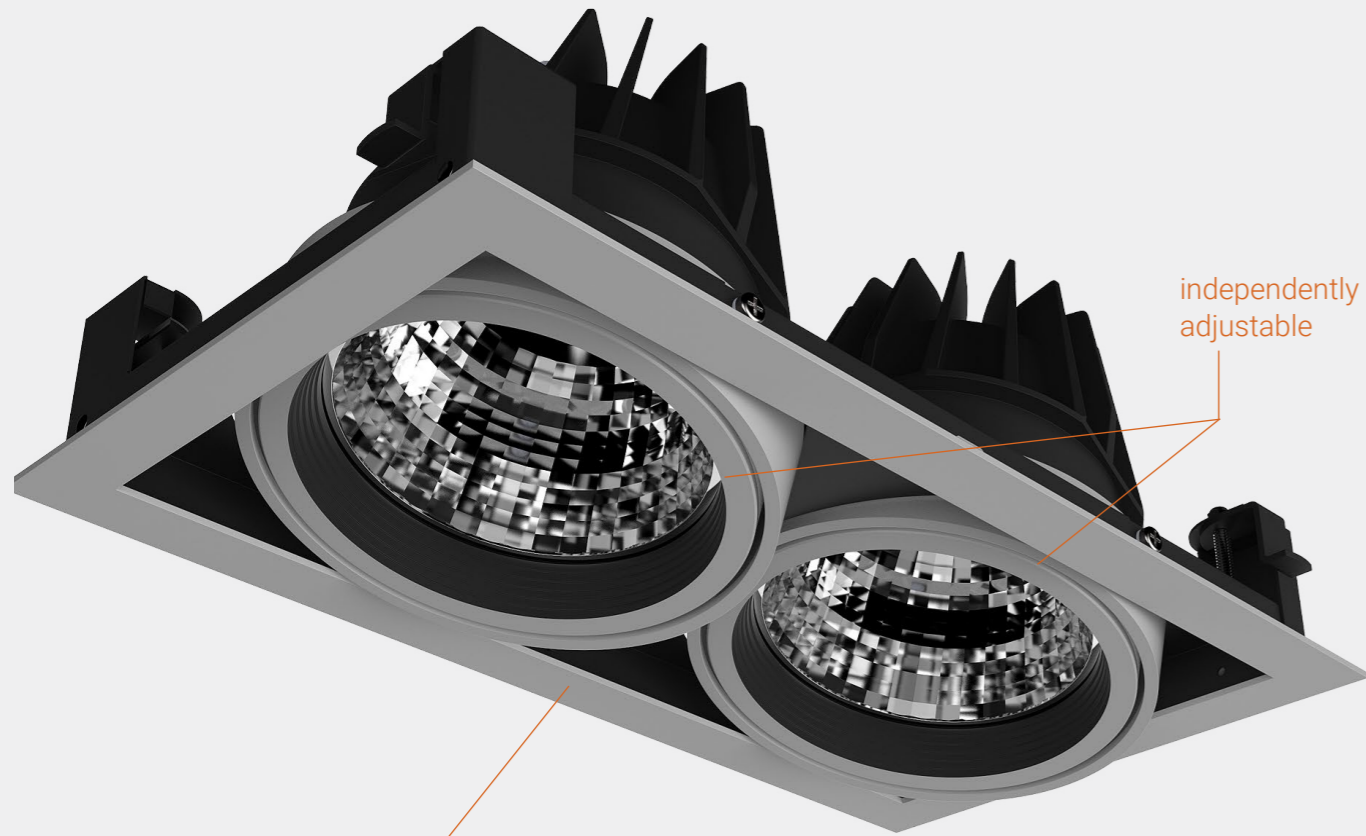

independently adjustable

die-cast aluminium housing

Product Family		Beam		Bezel Colour		CCT & Output		Suffix
S18151/2	20W Twin	SP	Spot	.05	White	10	3000K 20W	.8
S18155/2	28W Twin	FL	Flood	.04	Black	11	4000K 20W	
		WFL	Wide Flood	.21	Silver	02	3000K 28W	
						03	4000K 28W	

EM and dimmable options available - see page 30 for ordering info.

# Maxi Twin Gimbal

Interior Downlight

## LIGHT DETAILS

Wattage	CCT	Lumens	Efficacy
20W	3000K	2179lm	108lm/W
20W	4000K	2311lm	115lm/W
28W	3000K	2959lm	106lm/W
28W	4000K	3137lm	112lm/W

This twin version of the Maxi Gimbal allows for great directional flexibility. Independently adjustable, the two light sources allow for precise illumination.

Available with different beam options and outputs, as well as optional EM and dimmable control.

## PHOTOMETRY

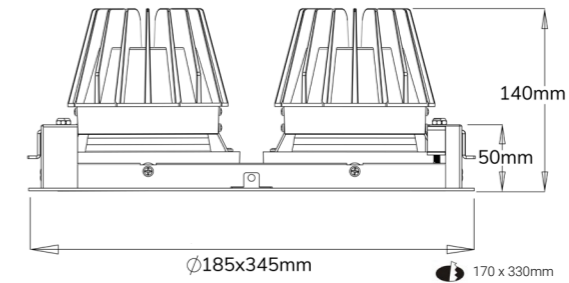
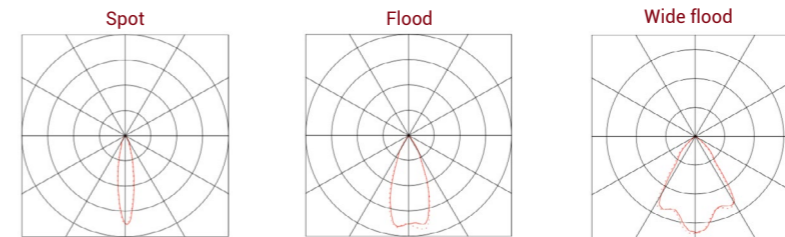

## TECHNICAL SPECIFICATIONS

IP rating	IP40
CRI	>90
Lamp Life	50,000 hours
Light Source	Osram PL-Core
Tilt	30°
Voltage	240V
Driver	High efficiency
Beam	Spot / Flood / Wide Flood
LED Warranty	5 Years

## HOUSING

Material	Aluminium
Finish	Powder coated
Protection Rating	Class 1
Optics	Clear glass
Weight	0.6kg
Mounting	Ceiling recessed

## Maxi Twin Gimbal

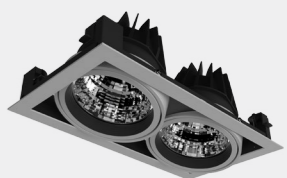

Ceiling Downlights





Product Family	Beam	Bezel Colour	CCT & Output	Suffix
S18151 Midi Gimbal	SP Spot	.05 White	20 3000K 18W	.8
	FL Flood	.04 Black	21 4000K 18W	
	WFL Wide Flood	.21 Silver	22 3000K 24W	
			23 4000K 24W	

EM and dimmable options available - see page 30 for ordering info.

# Midi Gimbal

Interior Downlight

## LIGHT DETAILS

Wattage	CCT	Lumens	Efficacy
18W	3000K	1627lm	90lm/W
18W	4000K	1633lm	90lm/W
24W	3000K	2575lm	107lm/W
24W	4000K	2730lm	113lm/W

## PHOTOMETRY

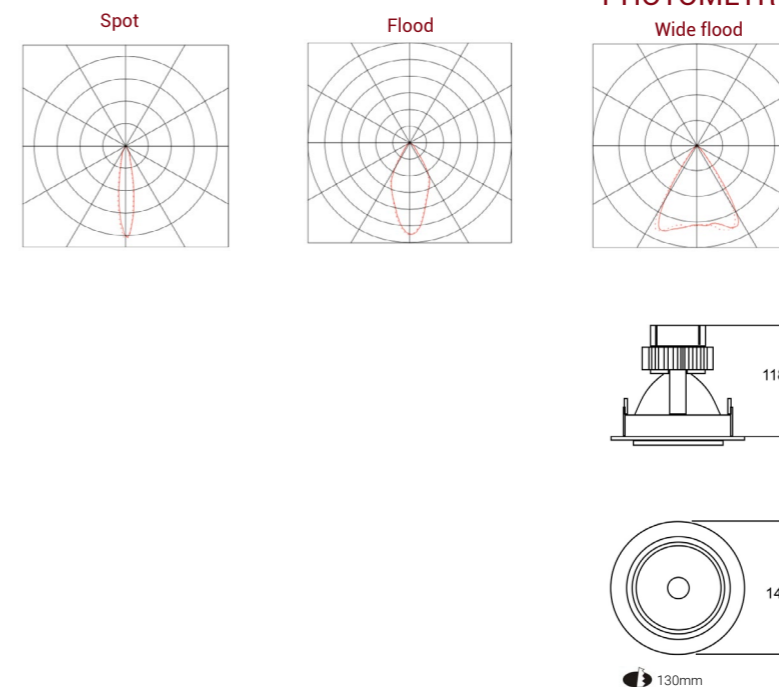

A beautifully compact high performance adjustable gimbal downlight, resulting in highly efficient light output in a fitting of just 140mm total diameter. Successfully used in major retail stores.

Available in a choice of outputs and colour temperature options. Supplied complete with high efficiency LED driver for optimum life and efficiency.

Main bezel and lamp housing of die-cast aluminium, with powder coated finish for durability. Standard colours white or black with other BS/RAL colours to order.

## TECHNICAL SPECIFICATIONS

IP rating	IP40
CRI	>90
Lamp Life	50,000 hours
Light Source	Tridonic SLE
Tilt	30°
Voltage	240V
Driver	High efficiency
LED Warranty	5 Years

## HOUSING

Material	Die-cast aluminium
Finish	Powder coated
Protection Rating	Class 1
Optics	Clear acrylic
Weight	0.6kg
Mounting	Ceiling Recessed





Product Family	Bezel Colour	CCT	Suffix
S18156 Scoop	.05 White	10 2700K	.8
	.04 Black	11 3000K	
	.21 Silver	12 4000K	

EM and dimmable options available - see page 30 for ordering info.

# Scoop

Interior Downlight

## LIGHT DETAILS

Wattage	CCT	Lumens	Efficacy
18W	3000K	2083lm	115lm/W
18W	4000K	2083lm	115lm/W
28W	3000K	3137lm	112lm/W
28W	4000K	3137lm	112lm/W

A high quality fully adjustable recessed downlight, allowing a 360° rotation and 45° tilt. An updated version of a mainstay of the Sovereign range, the Scoop utilises the most up-to-date LED technology to ensure optimum efficiency and light quality.

Available in any BS / RAL colour, with dimmable and emergency variants available. Offered with either 3000K or 4000k colour temperature

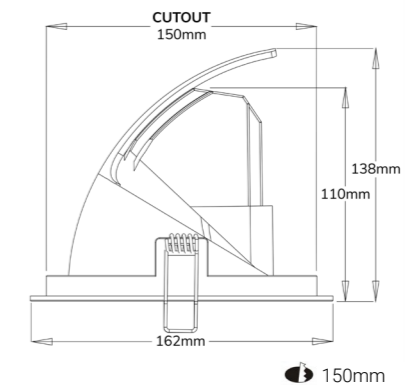
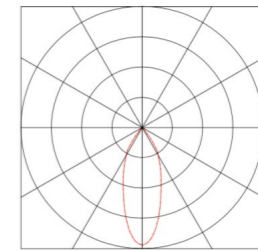

## TECHNICAL SPECIFICATIONS

IP rating	IP40
CRI	>90
Lamp Life	50,000 hours
Light Source	Osram LED
Tilt	45°
Rotation	360°
Voltage	240V
Driver	High efficiency

## HOUSING

Material	Aluminium
Finish	Powder coated
Protection Rating	Class 1
Optics	Clear glass
Weight	0.6kg
Mounting	Ceiling Recessed

### Scoop



Ceiling Downlights







# Dimming, Emergency & Lighting Control

All of our downlights are available with a full range of EM and lighting control options. To specify our downlights with our most popular lighting controls, insert the relevant code between the main product code and the suffix.

N.B.: When specifying control options without Emergency lighting options, include /20 under the Emergency selection (do not leave blank).

Product code	EM & Lighting Control Insert		Suffix
	Emergency	Control	
	/20 Non-EM	0 On / off	.8
	/21 Non maintained EM	1 1-10V dimming	
	/24 Maintained 3HR EM	2 DALI dimming	
	/26 DALI self test EM	5 Switch dim	
		6 DMX	
		7 Bluetooth	

Example: **S18156.0512.8**  
Scoop Downlight / White bezel / 3000K 18W

**S18156.0512/207.8**  
Scoop Downlight / White bezel / 3000K 18W / Bluetooth control

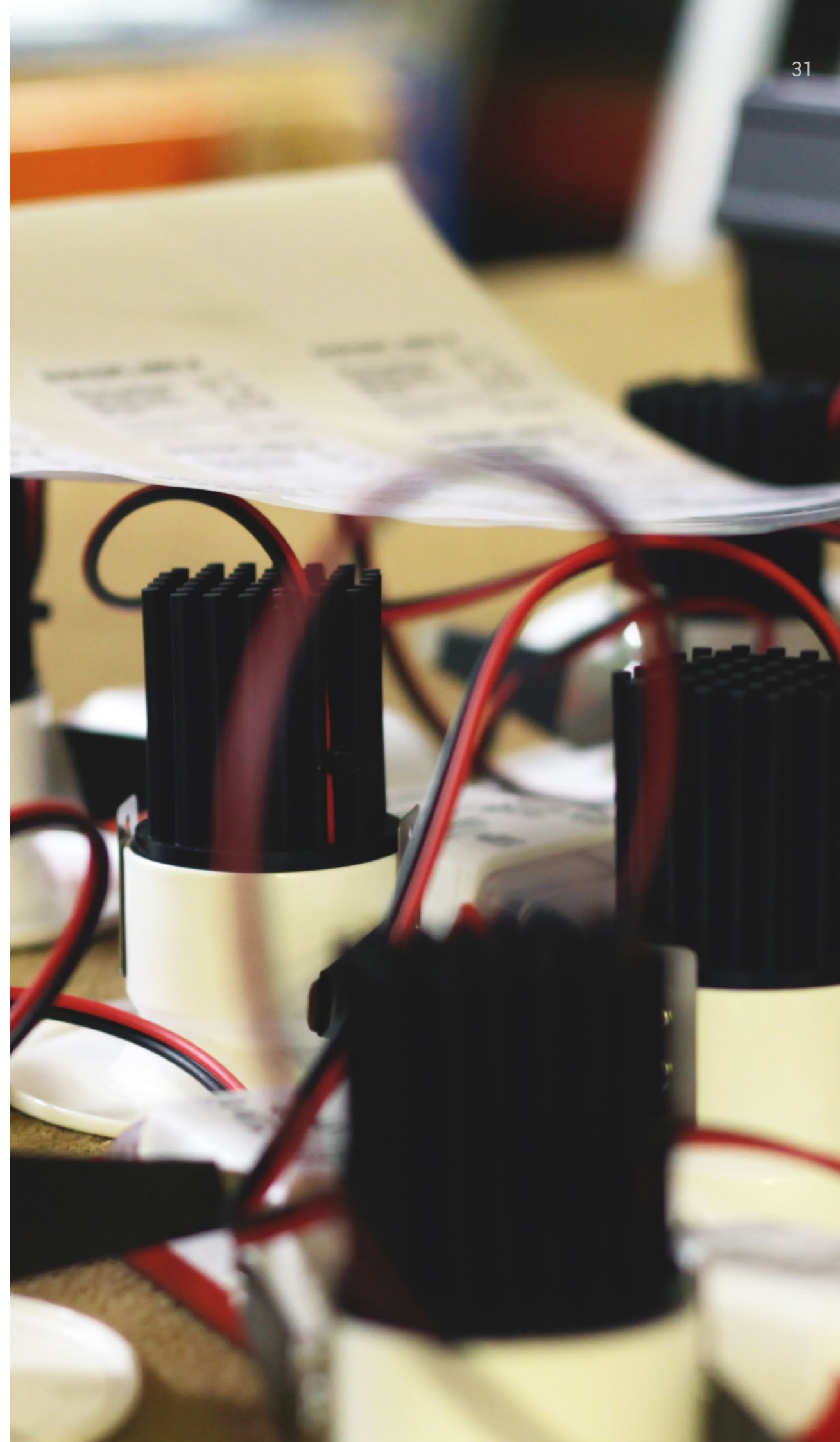



# Bespoke Design

## Product Modification

This catalogue lists only some of the options our Sovereign products offer. Commercial Lighting has extensive experience creating custom adaptations for our clients.

Need a specific housing colour, light source or bespoke colour rendering index? We can help.

## Custom Product Design

Need a unique feature pendant, a specific housing design, or a solution no currently offered in our Sovereign range? Get in touch.

Many of our Sovereign products began as custom designs made in collaboration with clients.

## Lighting Solutions

Our facilities include a dedicated in-house design team, metal workshop, in-house powder coating plant, and a team of experienced electrical assemblers.

This enables us to develop completely bespoke lighting solutions for any project.





# the ReVive service

Our ReVive service puts sustainability at the heart.

Utilising 20+ years experience in sensitive restoration and refurbishment, Commercial Lighting gives old products new life, bringing them in line with the very latest standards, efficiency and performance.

## The ReVive process:

- |   |              |   |
|---|--------------|---|
| 1 | Assessment   | We'll discuss all details of the current system with you to assess viability. We might ask for a sample or arrange collection via a site visit.   |
| 2 | Proposal     | Our technical team will create a full proposal, identifying the best solution for your project. This will comparison between current and proposed new fittings.   |
| 3 | First-off    | Our in house specialist production team will produce a sample for approval before full production. Depending on complexity, the conversions can be done in our manufacturing facilities, or custom upgrade kits can be sent for conversion on site. |
| 4 | Refurbish    | We refurbish and upgrade all your products and apply rigorous testing procedures.   |
| 5 | Installation | Your products are returned and re-installed using existing fixings for minimal disruption. Your fittings will be covered by our 5 year comprehensive warranty.  |



££

Cheaper than  
buying new



Less  
carbon impact



Less  
waste



Improved  
efficiency



Better  
illumination



Extended  
lifetime



## About us

Commercial Lighting Systems Ltd was established in Hampshire in 1991. The company is dedicated to offering the best quality, energy-efficient lighting to the UK market.

Our business is client-led, and made up of three divisions: reputable product ranges, bespoke design, and our flagship ReVive service for restoring and updating older lighting systems.

With almost 30 employees, many working here for over 20 years, our size lets us handle projects of any size. This allows us to maintain a personal approach to business, particularly advantageous for projects with unique specifications.

## Our Values

How we do business is just as important as the end product. Our approach is built around quality, honesty, and sustainability.

We continually invest in technologies that help us minimise our environmental impact. From solar panels and full EV fleet to our minimal waste policy, we ensure every stage of our operations is considered for its impact on the environment.





SOVEREIGN®

The signature range from  
Commercial Lighting Systems Ltd