

BOLT SEAL SEAL

Acme Reg No: 2108015

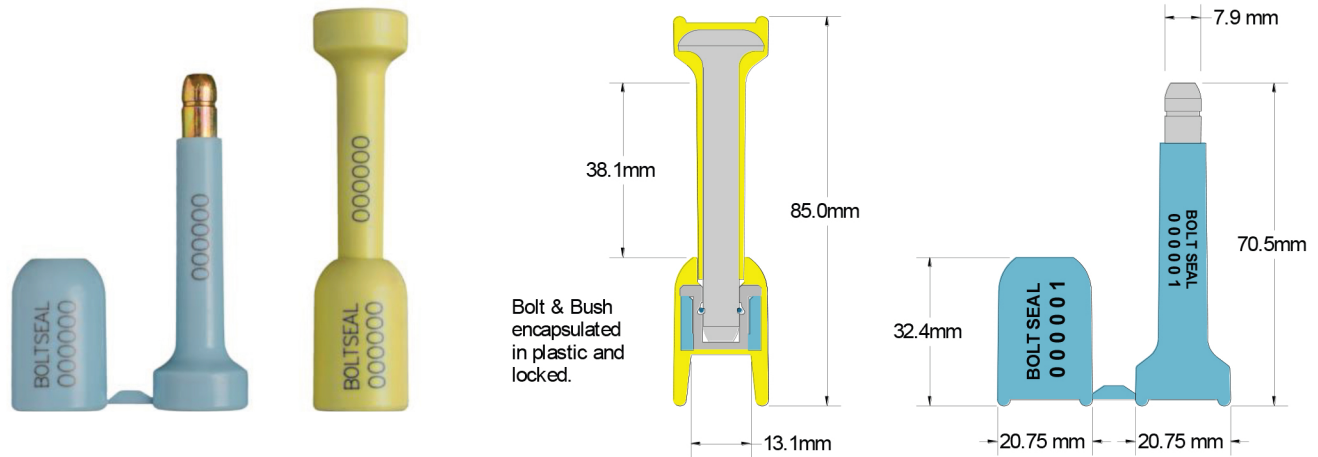

The Acme **Bolt Seal** is an ISO 17712:2013 (E) compliant high security bolt seal, designed for high value ISO container cargo shipments. The plastic coated bolt and locking bush are moulded as a unit and laser marked with identical sequential numbers for added security. The seals are packed in high quality clear re-closable wallets of ten seals, making it easy to remove seals singularly and then reclose the wallet. When the seal has been locked the bolt spins freely on the locking bush to confirm seal integrity. The seal can only be removed using bolt croppers.

Technical Data

Recommended Applications

Rail, Sea & Air Container Freight, Doors, Hatches, Trailers, Storage.

Material

Carbon steel with zinc chromate finish
 Bolt - High impact ABS coated
 Lock Bush - High impact ABS coated

Available Operating Length

38mm

Dimensions

Bolt - 18.8mm dia head and 7.9mm dia shaft
 Bush - 18.1mm dia head reducing to 12.0mm

Average Breaking Strength (Test Data)

Tensile Pull Strength -	20.20(kN)
Shear Test -	8.96 (kN)
Impact Test at 18° C -	40.68+(J)
Impact Test at -27° C -	40.68+(J)
Bending Test -	67.34(Nm)

Acceptance

ISO 17712:2013 (E) 'H' compliant High Security Seal
 HM Revenue & Customs High Barrier Seal Class 1
 EU Regulation 2454/93, Article 386, Annex 46A
 US In-Bond Security

Marking

“ACME SEALS GROUP” moulded into bolt and bush as manufacturer.
 “H” moulded into bolt and bush indicating high security bolt seal.
 Laser marking
 Consecutively numbered on bolt and bush as standard
 Optional Customer name/logo on bush

Colours

Pastel shades of pink, blue, green, yellow, peach, also black and white.
 Other colours may be available on request.

Packaging

Re-Closable Wallet	: 10 seals
Standard Packaging	: 200 seals per carton
Carton Dimensions	: 33cm x 23cm x 25cm
Carton weight	: 11.6kg per carton