

# ASME BPE Fittings

## DT-4.1.2-1 (DT-9) Equal Tee Weld Ended

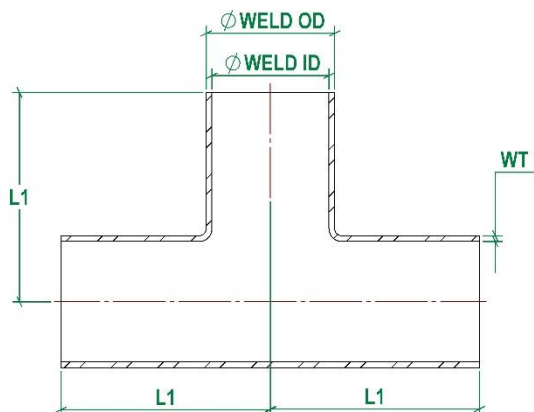
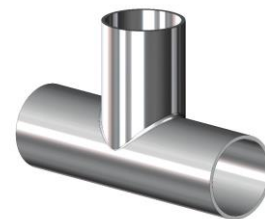

- Standard:** ASME BPE 2016, Imperial OD
- Material:** 316 Stainless Steel, EN1.4401
- Certification:** EN 10204-3.1
- Surface Finish (Internal):** SF1 - 0.51Ra Max
- Associated Standard:** ASME BPE 2009, 2012
- Associated Parts:** DT1 Tube, DT22 TC Ferrules
- Options:** SF4 – 0.38Ra & E/Polished Available Upon Request
- Remarks:** For Use in Bio-Pharmaceutical Applications

ASME BPE 2016 Fittings, DT-4.1.2-1 (DT9), Equal Tee Weld Ended

Size (inch)	TUBE OD (mm)	TUBE ID (mm)	WT (mm)	L1 (mm)	Part Code
0.500"	12.70	9.40	1.65	47.63	BPE.DT09.0050.SF1
0.750"	19.05	15.75	1.65	50.80	BPE.DT09.0075.SF1
1.000"	25.40	22.10	1.65	53.98	BPE.DT09.0100.SF1
1.500"	38.10	34.80	1.65	60.33	BPE.DT09.0150.SF1
2.000"	50.80	47.50	1.65	73.03	BPE.DT09.0200.SF1
2.500"	63.50	60.20	1.65	79.38	BPE.DT09.0250.SF1
3.000"	76.20	72.90	1.65	85.73	BPE.DT09.0300.SF1
4.000"	101.60	97.38	2.11	104.78	BPE.DT09.0400.SF1
6.000"	152.40	146.86	2.77	142.88	BPE.DT09.0600.SF1

Published Data Is Given in Good Faith. We Reserve the Right To, Without Warning Change the Dimensions When Not In Conflict With The Published Standard

### Flowsource Process Fittings

Unit 2F Hockney Road Industrial Estate, West Yorkshire, BD8 9HQ, United Kingdom  
 [T] 01535 274 316 - [e] sales@flowsourcepf.com - [w] www.flowsourcepf.com

