



SCAN MACHINES

The ultimate measurement
solution for cylindrical parts

 **SWISS
MADE**



Easy to use



Super fast



Very quick ROI

General features

APPLICATIONS

Our range of SYLVAC machines are designed to measure round parts with diameters up to 145 mm and up to 1'280 mm long. Most cylindrical parts, such as aerospace and automotive shafts and components, connectors, bone screws and dental implants, hydraulics parts, metal packaging for food and cosmetics, rollers, turbines parts, CNC turned parts, etc. can be measured in a few seconds. Various thread types and features can be measured and analyzed with our machines.



Workpiece Shadow image

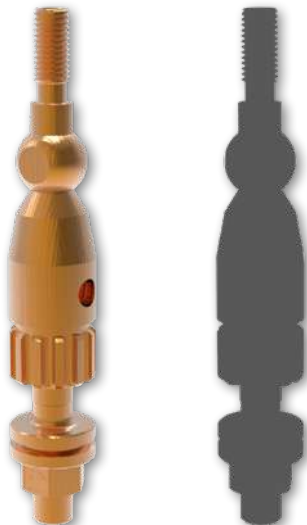

MEASURING PRINCIPLE

All Sylvac-Scan machines incorporate high resolution line-scan cameras. Using the green LED illuminator to project a collimated beam of light across the part, the part is scanned at speeds up to 100mm/s, whilst the contour of the part is collected through the high precision bi-telecentric lens system and the projected image is detected and processed using the latest line-scan camera technology.

The contour of the workpiece is reproduced on the software and all the various elements shown can be measured in static (without part rotation) or in dynamic (with part rotation) when geometrical features such as run-out or concentricity must be measured.

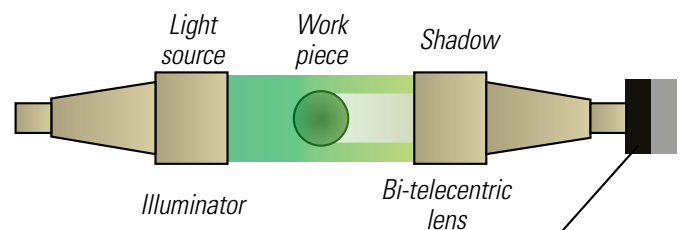

Work piece image

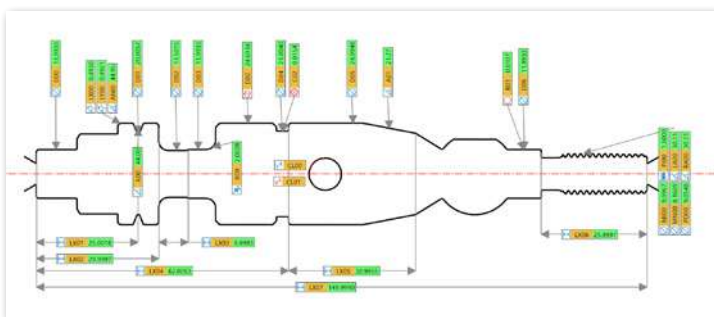
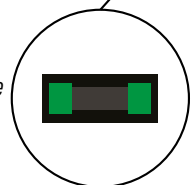



Increase efficiency

One click measurement

 Reduce inspection time

 Easy to use

 Increase efficiency

 Reduce scrap

 Save money

 Reduce CNC downtime

 Increase productivity

 Quick ROI

 Avoid QC bottle necks

Optical machines

SYLVAC SCAN

Optical machine specially designed for workshop measurement close to the machine-tool.

Suitable for first-off part, control in process (SPC), sampling or 100% inspection, our Sylvac SCAN machines are set to revolutionize the control in workshop.

SHOP HARDENED

Sylvac SCAN machines are Swiss made, quality, robust, precision measuring machines designed to work in even the harshest workshop environments. Our machines come with built in calibration masters which are used to keep the machines accuracy and performance within the required specification, compensating for temperature variations.

The S25/F60/S145 ranges, comes with the added value of temperature sensors, used to detect temperature variation and trigger an automatic calibration, which only takes a short moment. Ensuring the highest precision at all times.



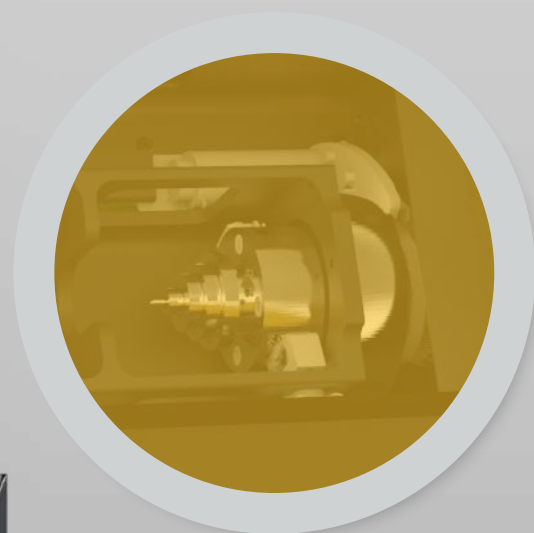

CALIBRATION
MASTER



ONE CLICK
MEASUREMENT



REFLEX-CLICK :
THE MEASURING SYSTEM THAT MAKES
EVERYONE AN EXPERT !

Operating principle

SYLVAC-REFLEX SCAN

The SYLVAC-SCAN's are equipped with Reflex SCAN software. These make them robust and easy to use, allowing perfect integration in workshops. Adjacent to operators, it advantageously replaces conventional measuring systems including multi-gauging thanks to unsurpassed flexibility and time saving.



«Reflex-Click technology» for one-click measurement !

The cutting edge REFLEX-Click mode measures your parts with a simple click.

PROGRAMMING MADE EASY

1

Place part



2

Push the start button



3

Part profile is scanned in just a few seconds



4

Main features automatically measured. Edit and save program for repeat work.

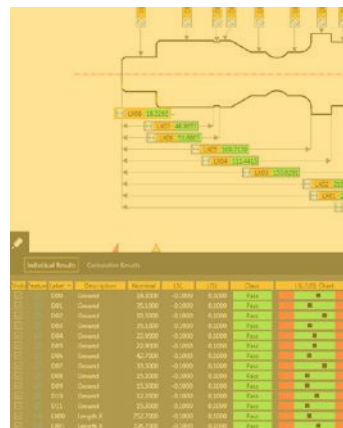

These four operations only take a few minutes.

MEASUREMENT MADE EASY

Step 1: load the part, Step 2: push the button!

The part will be automatically recognised and measured by the machine, displaying classified results in just a few seconds.

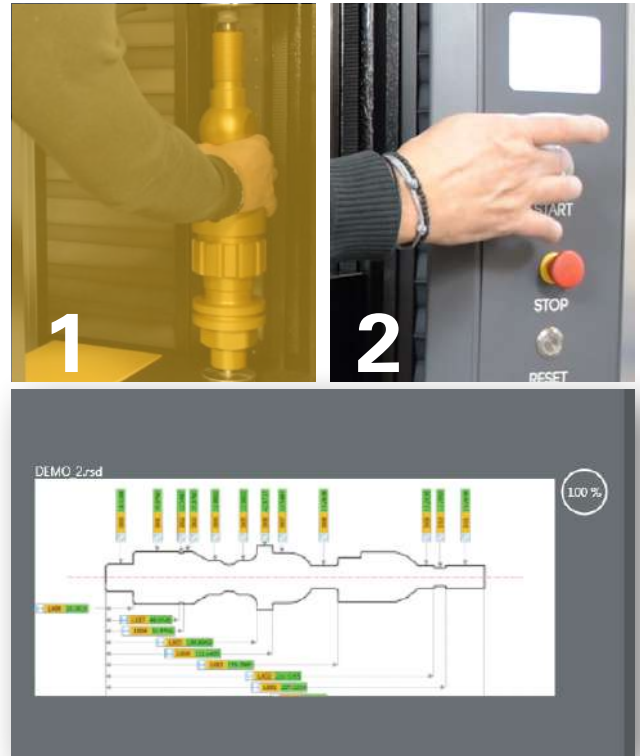

Intelligent automatic part recognition



BARCODE READER

Optionally a barcode reader can be used to instantly recall part programs.

FLEXIBLE REPORT EDITOR

A flexible report editor is also available, enabling you to customize the presentation of your measuring reports by adding information through a drag & drop method.

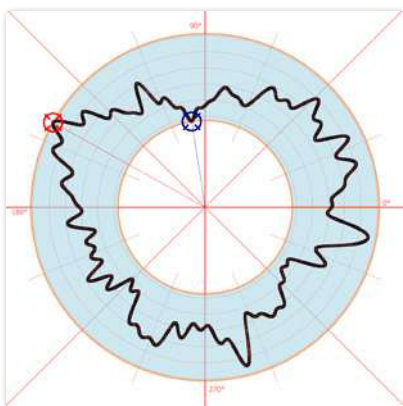

MEASUREMENT ANALYSIS

Once the part is scanned and measured, it is possible to review the scanned data in the measurement analysis window. Allowing the operator to make a visual check of the part in precise detail, whether it is a root radius on a thread or a form measurement of a diameter.

DATA EXPORT AND STATISTICS

The main statistical calculations are included as a standard feature in our RS+ software, along with a statistical view.

Results data can be exported in a variety of formats such as CSV, XML for the purpose of archiving and traceability. Or can be exported as specific formats directly into 3rd party SPC software.

Optionally you can take advantage of the Data Monitoring included with RS+ 'PRO' level software, facilitating live and historical result trends, evolution and distribution charts, statistics such as, CP/CPK, sigma, range and variance.

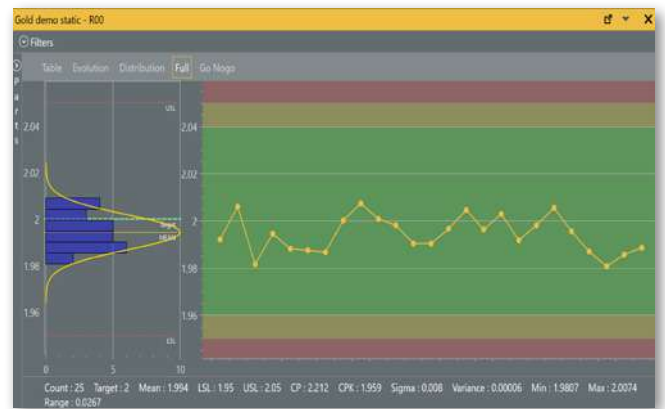

INTEGRATED MEASUREMENT

For additional measurements not covered by our SCAN machine, such as an internal diameter, Sylvac can provide a selection of instrument, such as calipers, indicators and internal micrometers.

These Sylvac instruments can be linked to the SCAN machine via our renowned *Bluetooth®* technology, providing a complete part measurement all in one report and sequence.

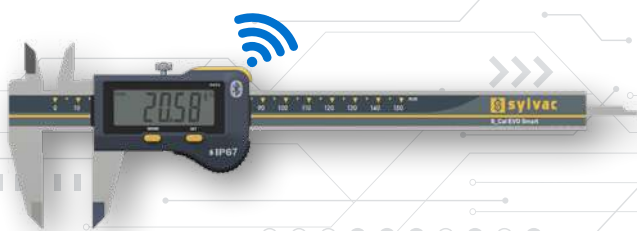

Exclusive Tilt system

FOR MORE COMPREHENSIVE THREAD MEASUREMENTS

The Sylvac-Scan machines equipped with the additional tilt 'T' axis (S25T/F60T/F60LT) offer the ultimate measurement solution for threaded parts.

Thanks to our unique tilting optics, the thread can be scanned according to the helix angle, revealing elements of the thread which would otherwise be hidden. Sylvac-Scan offers true thread measurement.

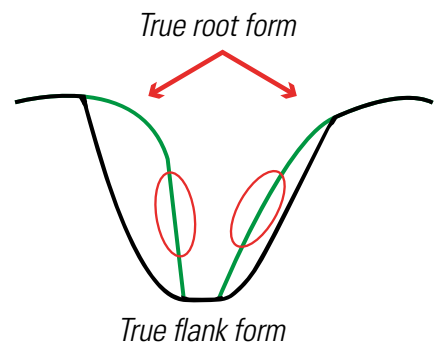
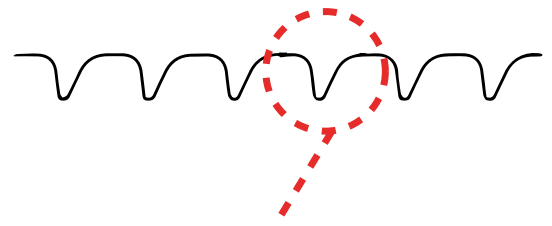
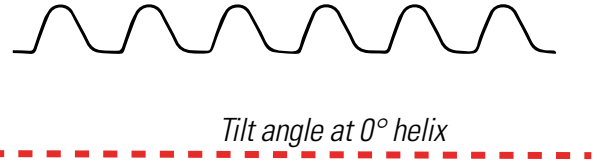

TYPICAL MEASUREMENT REQUIREMENTS:

- Major diameter
- Minor diameter
- Pitch
- Pitch diameter
- Flank angles
- Root & Crest radius
- Taper angle
- Circularity
- Run-out
- Concentricity

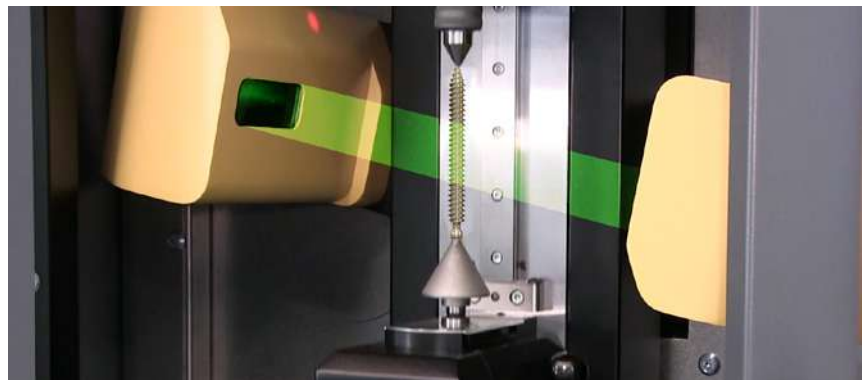

Axis inclination on F60T

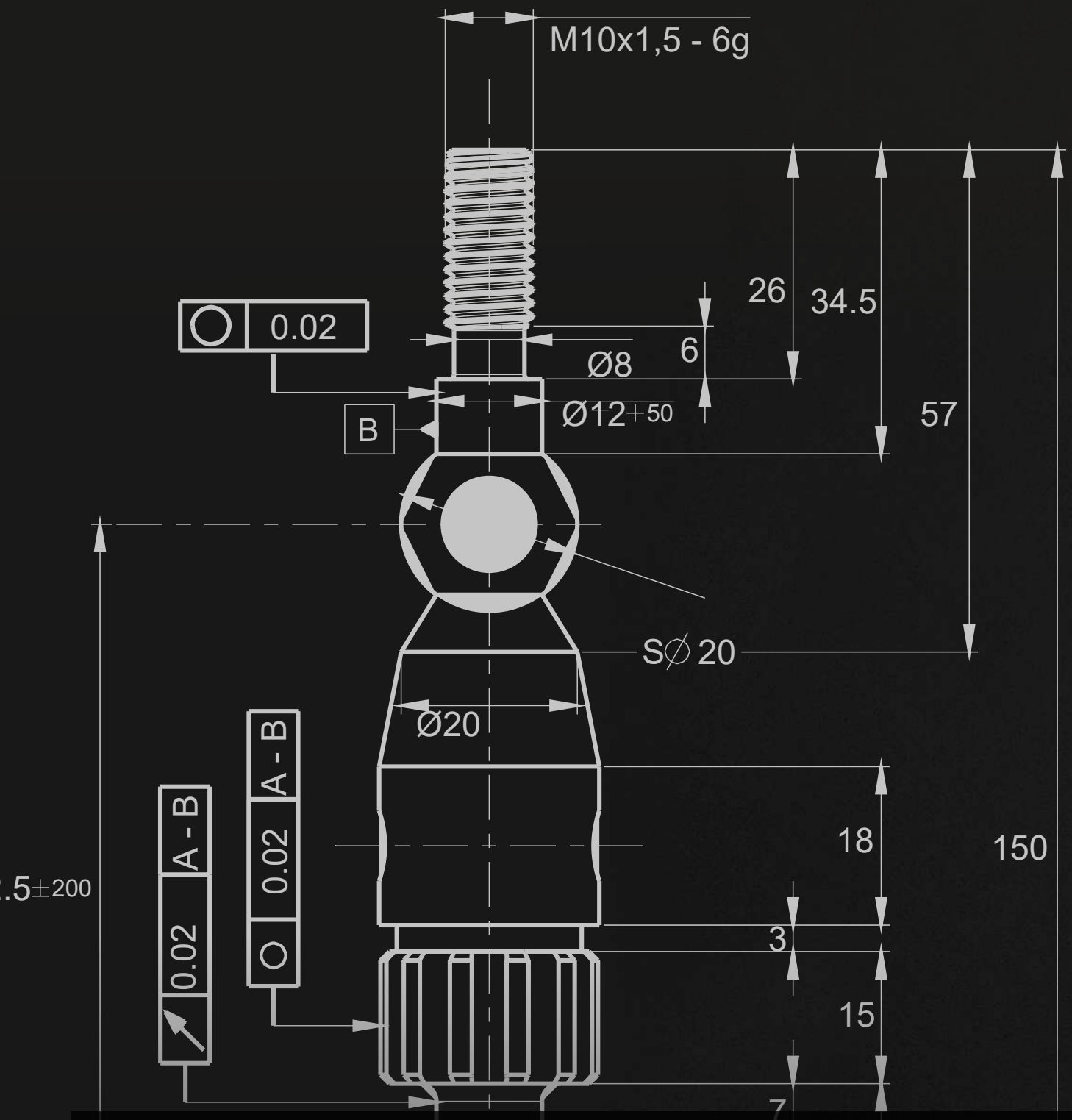

At the cutting-edge
of technology



1 CLICK
200 RATINGS
10 SECONDS



**CHECK OUT
THE VIDEO !**

Software features



CAD Software

CAD import/export

Advanced thread measurement

Advanced dust filtering



Access management- security level

Customisable operator interface

Formula wizard

Script function

BT Connectivity to Sylvac instruments

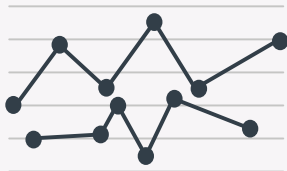

Easy to read results

Data export

Statistic view

Reports editor

Off-line programming

Automatic part/program recognition



Easy to use

Automatic measurement of the main features

One-click measurement

Sylvac SCAN S25 & S25T



- Bench top machine for smaller parts
- Integrated operator touch screen control panel
- Integrated calibration master & temperature sensors for environmental control
- Quick and easy accessory changing system
- High definition optics suited to micro parts
- Reflex click technology
- Tilt axis for advanced thread measurement
- Advanced software features
- Fully equipped «Automation Ready»
- Motorised tailstock
- High resolution sensor for intricate features

TECHNICAL SPECIFICATIONS

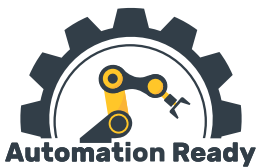

TILTING SYSTEM

		902.4020 - SCAN S25		902.4025 - SCAN S25T	
		Diameter	Length	Diameter	Length
Measuring range	mm	26	200	26	200
Resolution	mm	0.0001			
Accuracy	µm	Diameter : 0.9 + (D[mm]/100) / Length : 2.5 + (L[mm]/200)			
Repeatability 2σ	µm	Diameter : 0.5 / Length : 0.8			
Holding capacity	mm	51	200	51	200
Tilting for thread measurement		-		✓ 30°	
Axial move speed up to	mm/s	100			
Max. part weight	kg	3			
Machine weight	kg	73			

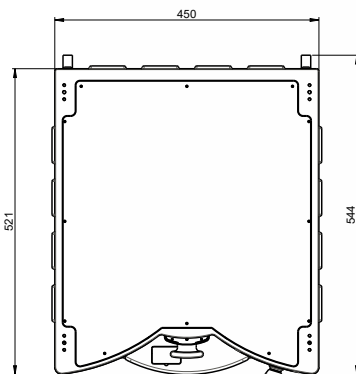

DELIVERY

- Machine according to technical specifications
- Computer with screen, keyboard and mouse
- Windows multilingual operating system
- Sylvac Reflex SCAN Software +
- Accessories : 2x 902-6259 ISO / MK2 adapter, 2x 902-6202, 902-6161 & 902-6212
- Manual

Sylvac SCAN F60(T) & F60L(T)

- Capable mid size machine for general and complex parts
- Single pass rapid scan 100mm/s
- Quick release tooling
- Large LED status light
- Safety light curtain
- Integrated calibration master & temperature sensors for environmental control
- Reflex click technology
- Tilt axis for advanced thread measurement
- Advanced software features
- Optional custom scripts
- Dust filtering for part contamination



TECHNICAL SPECIFICATIONS

		902.4060 - SCAN F60		902.4065 - SCAN F60T		902.4062 - SCAN F60L		902.4067 - SCAN F60LT	
		Diameter	Length	Diameter	Length	Diameter	Length	Diameter	Length
Measuring range	mm	64	300	64	300	64	500	64	500
Resolution	mm	0.0001							
Accuracy	µm	Diameter : 1.0 + (D[mm]/100) / Length : 3 + (L[mm]/200)							
Repeatability 2σ	µm	Diameter : 0.5 / Length : 1.8							
Holding capacity	mm	120	315	120	315	120	500	120	500
Tilting for thread measurement		-		✓ 30°		-		✓ 30°	
Axial move speed up to	mm/s	100							
Max. part weight	kg	10							
Machine weight	kg	265				330			

DELIVERY

- Machine according to technical specifications
- Accessories : 2x 902-6202, 902-6161, 902-6212
- Computer with screen, keyboard and mouse
- Windows multilingual operating system
- Sylvac Reflex SCAN+ Software
- Manual

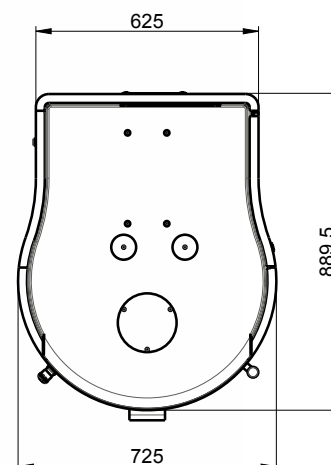

Sylvac SCAN S145 & S145L



- Free standing machine for larger parts with heavy weight loads
- Automation ready
- Removable roof for heavy part loading
- Motorised tailstock
- Quick release tooling
- LED status light
- Safety light curtain
- Integrated calibration master & temperature sensors for environmental control
- Reflex click technology
- Advanced software features
- Optional custom scripts

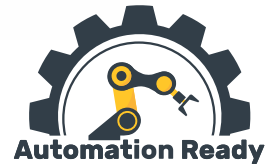

TECHNICAL SPECIFICATIONS

		902.4145 - SCAN S145		902.4147 - SCAN S145L	
		Diameter	Length	Diameter	Length
Measuring range	mm	145	615	145	1280
Resolution	mm	Diameter : 0.0001 / Length : 0.0001			
Accuracy	µm	Diameter : 1.5 + (D[mm]/100) / Length : 4 + (L[mm]/200)			
Repeatability 2σ	µm	Diameter : 0.5 / Length : 1.0			
Holding capacity	mm	254	615	254	1280
Rotary headstock		✓		✓	
Axial move speed up to	mm/s	160			
Max. part weight	kg	100			
Machine weight	kg	530		650	

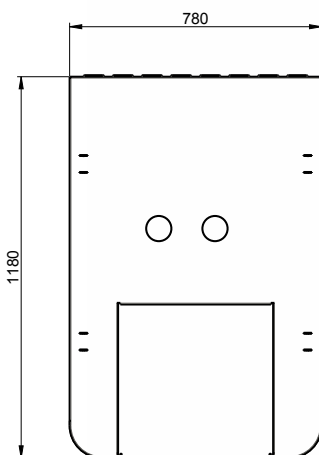

DELIVERY

- Machine according to technical specifications
- 2 Adaptors for Morse 2 (902-6260), rotative centre 42mm (902-6380) et drive centre (902-6210)
- Computer with screen, keyboard and mouse
- Machine stand, with screen & keyboard holder
- Windows multilingual operating system
- Sylvac Reflex SCAN+ Software
- Manual

Specifications of the softwares

FUNCTIONS	Sylvac Reflex SCAN	Sylvac Reflex SCAN+	Sylvac Reflex SCAN+ PRO
Automatic measurement of the main features (diameters, lengths, angles, radius)	✓	✓	✓
Automatic parts / program recognition	✓	✓	✓
Reports editor	✓	✓	✓
Data export	✓	✓	✓
SPC basic calculation	✓	✓	✓
Access management - security level	1	Multiple	Multiple
Off-line programming		Optional	Optional
Advanced dust filtering		✓	✓
Statistic view		✓	✓
CAD Import / Export / Compare			✓
Script function			✓
Monitoring SPC module			✓
Thread wizard for custom threads			✓

GEOMETRICAL TOLERANCING - FEATURES SUMMARY	Sylvac Reflex SCAN	Sylvac Reflex SCAN+	Sylvac Reflex SCAN+ PRO
Diameters	✓	✓	✓
Lengths, heights, distances	✓	✓	✓
Angles, chamfers	✓	✓	✓
Radii	✓	✓	✓
Roundness	✓	✓	✓
Cylindricity	✓	✓	✓
Across flats	✓	✓	✓
Rotational diameters	Basic	✓	✓
Run out	Basic	✓	✓
Concentricity	Basic	✓	✓
Threads (parallel)	✓	✓	✓
Threads taper		✓	✓
Advanced threads (root detail, taper, multi-starts, worm screws,...)		✓ Tilt machines only	✓ Tilt machines only
Custom threads (bone-screws, dental implants, etc.)			✓
Perpendicularity		✓	✓
Form deviation		✓	✓
Straightness		✓	✓
Interrupted parts (splines, turbines)		✓	✓

Investment

SYLVAC SCAN MACHINES QUICK ROI

Because the return on investment is essential data to make sensible decisions, SYLVAC can help you calculate your estimated payback time. It will directly depend on the profile of your company and the expected use of the machine.

You can see for yourself that your return on investment will be less than than 6 months in most cases. Moreover, the quality of your measurements will be improved!



TRADITIONAL MANUAL METHODS USING MULTIPLE GAUGES :



10-30 min
INSPECTION TIME

SYLVAC-SCAN SERIES :



30-60 sec
INSPECTION TIME

Tailor-made solutions

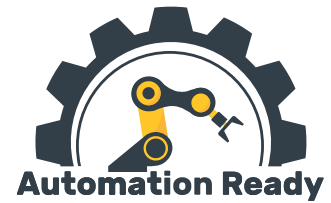

CLAMPING SOLUTIONS

Apart from our standard range of fixtures, customised solutions can be developed to optimise your measuring process.

SOFTWARE

Thanks to the Reflex SCAN+ and its flexible open script option, custom software features and macros can be created.



Example of SCAN F60 with robot



Example of SCAN S25T with robot

MEASURING TURNED PARTS HAS NEVER BEEN SO EASY !

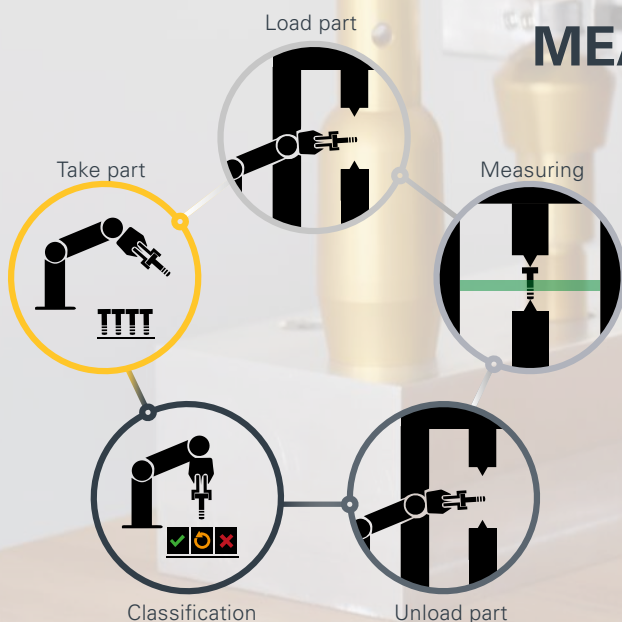

- Quality control for your shafts just got easier !
- The Sylvac-Scan range of optical measuring centres, now available fully automated
- Rapid automatic part loading/unloading by a robot, classification feedback for specified drop location
- Machine tool feedback for part correction / offsets

Applications



PACKAGING



COSMETICS



PLUMBING



PLASTICS

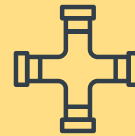

HYDRAULIC



PNEUMATIC



CONNECTORS



AUTOMOTIVE



AEROSPACE



INJECTION MOULDING



PHARMA



ELECTRO MOTORS



MUNITIONS



THREADS



WATCH INDUSTRY

We can measure all your components with our optical machines dedicated to the industry.

Accessories

CENTRES AND DRIVE CENTRES

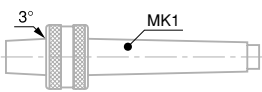
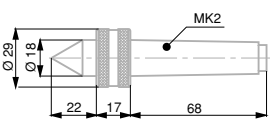
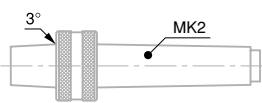
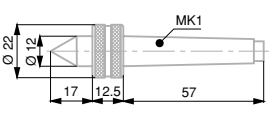
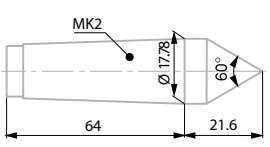
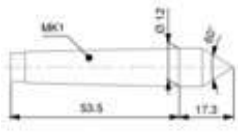
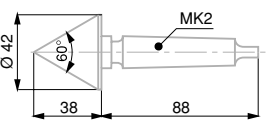
		S25T	Morse 2 F60	S145	
	902-6000	Male centre 10 mm MK1	• Requires 902-6360	• Requires 902-6360	• Requires 902-6360
	902-6160	Rotation centre with a B12 male taper plus a Morse 1 taper shank	• Requires 902-6360	• Requires 902-6360	• Requires 902-6360
	902-6161	Rotation centre, Morse 2	•	•	•
	902-6162	Rotation centre with a B18 male taper plus a Morse 2 taper shank	•	•	•
	902-6163	Rotation centre, Morse 1	• Requires 902-6360	• Requires 902-6360	• Requires 902-6360
	902-6202	Male centre 17.78 mm, extra (Standard delivery with Sylvac-SCAN S25, F60 and S145)	•	•	•
	902-6203	Drive centre (Diamond coated 10mm)	• Requires 902-6360	• Requires 902-6360	• Requires 902-6360
	902-6210	Drive centre, Ø 42 mm plus a Morse 2 taper shank Diamond coated	•	•	•

CENTRES AND DRIVE CENTRES

 **IMAGE SOON AVAILABLE**

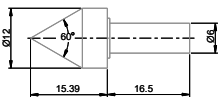
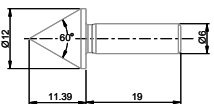
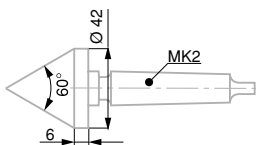
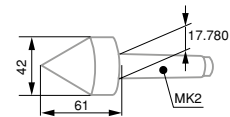
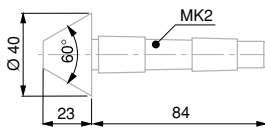
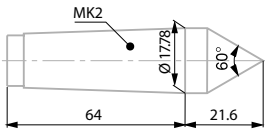

CENTRES AND DRIVE CENTRES		S25T	Morse 2 F60	S145
902-6211	Non diamond coated Drive centre Ø 42mm	•	•	•
902-6212	Centre MK2 diamond coated, Ø 17mm	•	•	•
902-6341	Male centre, Ø 15-40 mm, plus a Morse 2 taper shank	•	•	•
902-6380	Rotation centre Ø 42mm MK2	•	•	•
902-6410	Drive centre - diamond coated with reference diameter. Ø 42 mm max	•	•	•
902-6420	Small male centre	• Requires 902-6251		
902-6421	Small male rotating centre	• Requires 902-6251		

INVERTED V-CENTRES

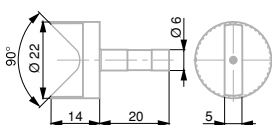
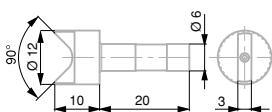

902-6204	Female centre Ø10mm Capacity Ø3 - 10mm	• Requires 902-6251	• Requires 902-6251	• Requires 902-6251
902-6205	Female centre Ø20mm Capacity Ø5 - 20mm	• Requires 902-6251	• Requires 902-6251	• Requires 902-6251

Accessories

INVERTED V-CENTRES

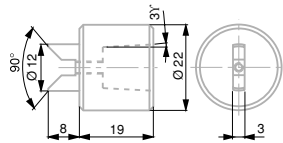
**902-6206**

Rotating female centre Ø10mm
Capacity Ø3 - 10mm

S25T**Morse 2
F60****S145**

•
Requires
902-6360
902-6160

•
Requires
902-6360
902-6160

•
Requires
902-6360
902-6160

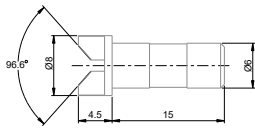
**902-6214**

Small female centre 5mm

•
Requires
902-6251

•
Requires
902-6251

•
Requires
902-6251

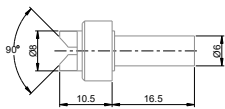
**902-6215**

Small rotating female centre 5mm

•
Requires
902-6251

•
Requires
902-6251

•
Requires
902-6251

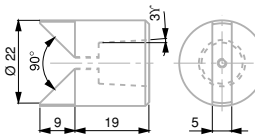
**902-6207**

Rotating female centre Ø20mm
Capacity Ø5 - 20mm

•
Requires
902-6360
902-6160

•
Requires
902-6360
902-6160

•
Requires
902-6360
902-6160

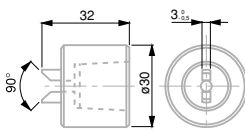
**902-6310**

Female centre Ø10mm
Capacity Ø3 - 10mm

•
Requires
902-6162

•
Requires
902-6162

•
Requires
902-6162

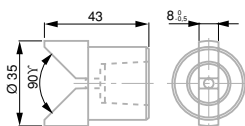
**902-6311**

Rotating female centre Ø30
Capacity Ø5 - 30mm

•
Requires
902-6162

•
Requires
902-6162

•
Requires
902-6162

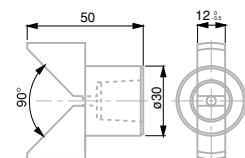
**902-6312**

Female centre Ø45mm

•
Requires
902-6162

•
Requires
902-6162

•
Requires
902-6162

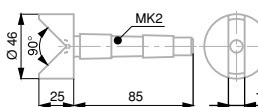
**902-6340**

Female centre Ø40mm MK2
Capacité Ø5 - 40mm

•

•

•

MANUAL CHUCKS

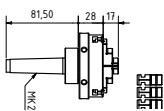
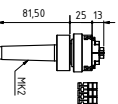
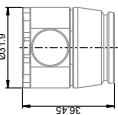
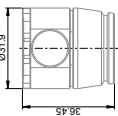
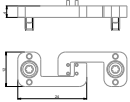
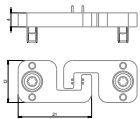
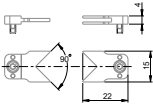
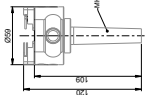
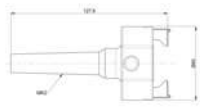

		S25T	Morse 2 F60	S145
902-6222	External 2-jaw gripper MK2	•	•	• Requires 902-6260
902-6270	2-jaw gripper Ø 1-19.5mm MK2 (delivered without jaws)	•	•	•
902-6271*	External jaws Ø1-19.5mm, H=4mm for gripper 902-6270	• For 902-6270	• For 902-6270	• For 902-6270
902-6272*	External jaws Ø 2-5mm, H=2mm (for gripper 902-6270)	• For 902-6270	• For 902-6270	• For 902-6270
902-6273*	External jaws Ø 5-10mm, H=3mm (for gripper 902-6270)	• For 902-6270	• For 902-6270	• For 902-6270
902-6274*	External jaws Ø 1-19.5, H=8mm (for gripper 902-6270)	• For 902-6270	• For 902-6270	• For 902-6270
902-6275*	External jaws Ø 1-19.5mm, H=14mm (for gripper 902-6270)	• For 902-6270	• For 902-6270	• For 902-6270
902-6276*	Jaw raiser, H=10mm (for gripper 902-6270)	• For 902-6270	• For 902-6270	• For 902-6270
902-6280*	Micro pincer Ø 0.1 - 1.00mm (10 - 75g clamping force)	•		
902-6281*	Micro pincer Ø 0.5 - 2.50mm (50 - 250g clamping force)	•		
902-6306	3-jaw chuck MK2 External clamping Ø 0.5mm - 41mm Internal clamping Ø 12mm - 36mm Step Height : 5mm	•	•	• Requires 902-6260
902-6307	3-jaw chuck MK2 External clamping Ø 1mm - 71mm Internal clamping Ø 18mm - 66mm Step Height : 10mm		•	• Requires 902-6260
902-6308	3-jaw chuck ISO40 External clamping Ø 1mm - 150mm Internal clamping Ø 34mm - 174mm Step Height : 10mm			•

*Coming soon

Accessories

MANUAL CHUCKS

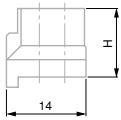
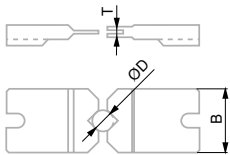
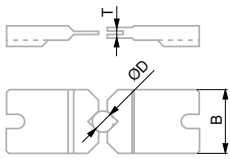

		S25T	Morse 2 F60	S145
<p>902-6140 6÷12mm / T=15mm</p> <p>902-6141 0÷6mm / T=1.5mm</p> <p>902-6142 0÷6mm / T=3mm</p> <p>902-6143 6÷12mm / T=15mm</p> <p>902-6144 12÷18mm / T=6mm</p> <p>902-6145 18÷24mm / T=9mm</p> <p>902-6152 0÷6mm / T=6mm</p> <p>902-6153 0÷6mm / T=15mm</p>	External jaws, in pairs	For 902-6220, 902-6221, 902-6222, 902-6223	For 902-6220, 902-6221, 902-6222, 902-6223	For 902-6220, 902-6221, 902-6222, 902-6223
<p>902-6154 Set with 5 articles</p>	External jaws, in pairs 902-6141 : Jaws dia 0-6mm, T1=1.5mm, B=18mm 902-6142 : Jaws dia 0-6mm, T1=1.3mm, B=18mm 902-6143 : Jaws dia 6-12mm, T1=3mm, B=18mm 902-6144 : Jaws dia 12-18mm, T1=6mm, B=20mm 902-6145 : Jaws dia 18-24mm, T1=9mm, B=25mm	Requires 902-6220, 902-6221, 902-6222, 902-6223	Requires 902-6220, 902-6221, 902-6222, 902-6223	Requires 902-6220, 902-6221, 902-6222, 902-6223
<p>902-6231 H=22</p>	Raising blocks for external jaws, in pairs	Requires 902-6220, 902-6221, 902-6222, 902-6223	Requires 902-6220, 902-6221, 902-6222, 902-6223	Requires 902-6220, 902-6221, 902-6222, 902-6223

PNEUMATIC CHUCKS

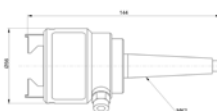
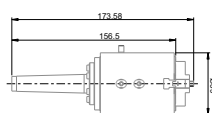
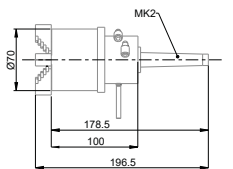

		S25T	Morse 2 F60	S145
902-6309	3-jaw pneumatic chuck MK2 1mm - 60mm		●	
902-6316*	Small 3-jaw pneumatic chuck MK2 0.5mm - 41mm	●		
902-6318*	Large 3-jaw pneumatic chuck ISO40 1mm - 150mm			●
902-6223	2-jaw pneumatic chuck MK2	●	●	

*Coming soon

PLATES

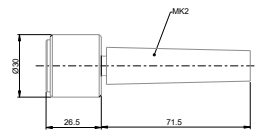
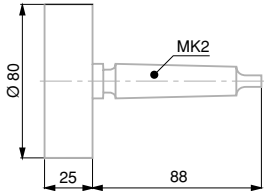
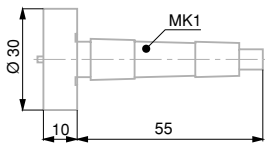

902-6208	Plate, Ø 30 mm MK1	• Requires 902-6360	• Requires 902-6360	• Requires 902-6360
902-6209	Plate, Ø 80 mm MK2		•	•
902-6228	Magnetic clamping plate Ø0-24 mm MK2	•	•	•

ADAPTERS

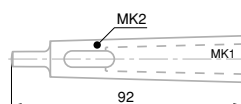
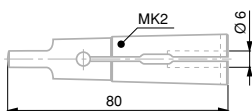
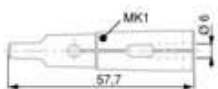
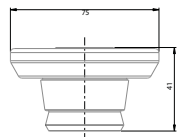
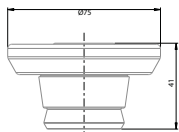
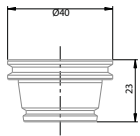

		S25T	Morse 2 F60	S145
902-6258	Adapter MK1 for SCAN S25	•		
902-6259	Adapter MK2 for SCAN S25	•		
902-6260	Adapter MK2 for SCAN S145			•
902-6263	Adapter MK3 for SCAN S145			•
902-6250	Adapter with bore Ø 6 mm MK1	• Requires 902-6360	• Requires 902-6360	• Requires 902-6360
902-6251	Adapter with bore Ø 6 mm MK2	•	•	•
902-6360	Reduction sleeve DIN 2185 MK A/I 2:1	•	•	•

Accessories

GRIPPING OF SMALL PARTS

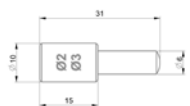
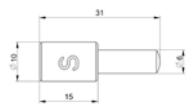















		F60	S145	S25
902-6330	Centered magnetic plate, magnetized - SUD for the headstock			• Requires 902-6251
902-6335	Magnetic gripper with V for parts with Ø0.4mm - 1.3mm tip, magnetized - NORD			• Requires 902-6251
902-6336	Magnetic gripper with V for parts with Ø0.6mm - 2.0mm tip, magnetized - NORD			• Requires 902-6251
902-6337	Magnetic gripper with V for parts with Ø2.0mm - 3.0mm tip, magnetized - NORD			• Requires 902-6251
902-6339	Set of 3 NORTH magnetic plates (902-6335, 902-6336, 902-6337) and 1 SOUTH magnet (602-6330)			• Requires 902-6251

SOFTWARE OPTIONS



		F60	S145	S25
***	Reflex SCAN+ Standard (delivered with 902-4060, 902-4062, 902-4065, 902-4067, 902-4020 & 902-4025)	•	•	•
902-7015	Reflex SCAN+ Offline Software	•	•	•
902-7017	Reflex-SCAN+ Automation software module (Option, require Reflex SCAN+, standard delivery with S145 and S25)	•	•	•
902-7021	Reflex-Scan+ «PRO» including, advanced thread wizard, CAD compare, Monitoring SPC, scripting	•	•	•
902-7022	Reflex-SCAN+ PRO Offline	•	•	•

OTHER ACCESSORIES

		F60	S145	S25
	902-6012	Gold demo part		•
	902-6013	Gold demo part for threads		•
	902-6014	Gold demo part XL		•
	902-6600	Table for Sylvac SCAN F60 (85x85x70cm)		•
	902-6601	Furniture for Sylvac SCAN F60 storage for PC, drawer with lock and arm for keyboard and screen		•
 IMAGE SOON AVAILABLE	902-6602	Table for Sylvac-Scan S25T (75cmx75cm) selectable height 75cm or 105cm		•
	902-6605	Height-adjustable table (71-1140mm) for keyboard, screen and mouse (80x60mm)		•
	902-6607	Accessories tidy insert for drawer (included with 902-6601)		•
	902-6006	Plastiform case for SCAN and VISIO		•
	902-6609	Rack		•
	902-6611	Option table 700mm (replaces the standard 350mm table)		•
 IMAGE SOON AVAILABLE	902-6608	Automation preparation for F60 series (I/O & Pneumatic prep, includes 902-7017)		•
 IMAGE SOON AVAILABLE	902-6610	Pneumatic actuation of tailstock for F60 series		•
 IMAGE SOON AVAILABLE	602-104-01	Protective cover		•

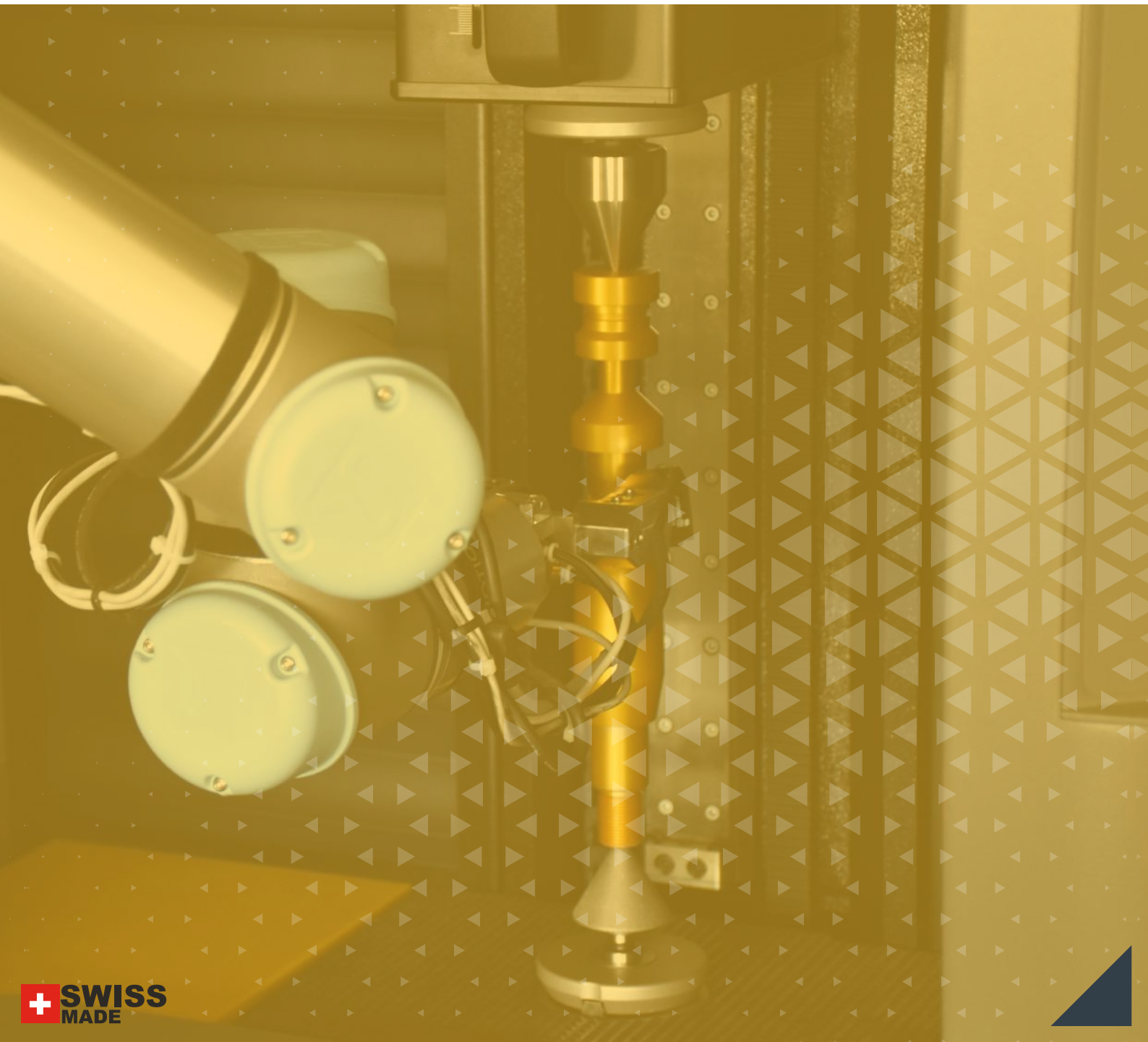

SYL2106-L-SCAN-E / 05.09.2022

Sylvac SA

Avenue des Sciences 19, 1400 Yverdon-les-Bains

Tel : +41 21 637 67 57

Web : www.sylvac.ch

Email. sales@sylvac.ch