

SR721-SP Open scale

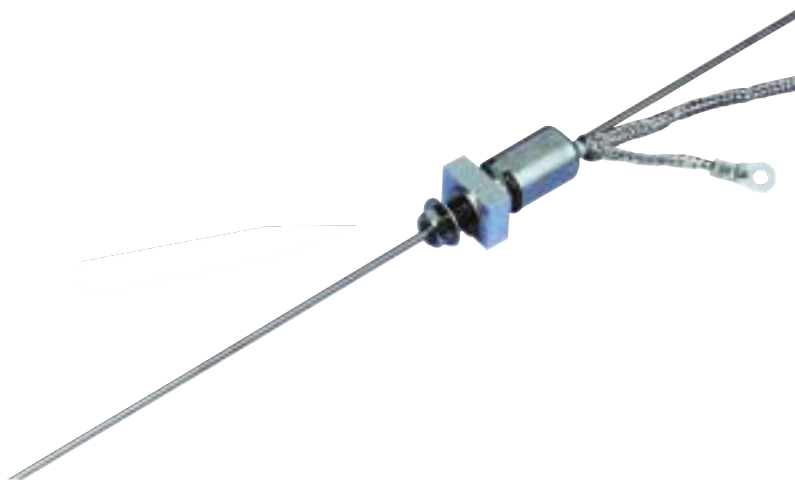

Compatible with



Specifications

SR721-SP	
Measuring length L	150 / 200 / 250 / 300 / 350 / 400 mm
Total length	L + 150mm
Scale diameter	2mm
Accuracy (at 20°C)	± 5μm
Resolution	0.5μm, 1μm, 2μm, 5μm, 10μm
Permissible installation tolerance	// 0.01mm / 50mm Slope of the machine guide in the rod scale holder
Thermal expansion coefficient	(14 ± 1) × 10 ⁻⁶ / °C
Operating temperature	-5°C to 40°C
Storage temperature	-10°C to 50°C
Cable length - reading head	1m

Dimensions

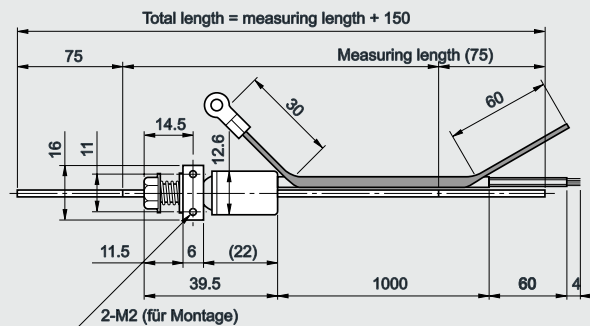
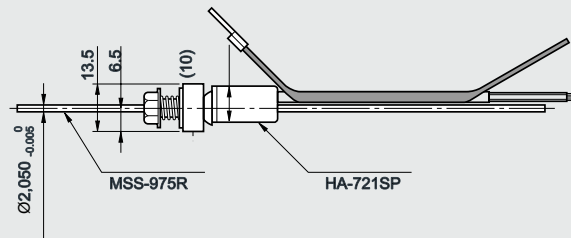

Unit: mm

⚠ To use this product safely, please read the instruction manual carefully and thoroughly prior usage.
 Magnescale reserves the right to change product specifications without prior notice.
 MAGNESCALE is a trademark of Magnescale Co., Ltd., Japan

The contents of this data sheet are as of June 2021