

SF Auto-fill Counter Top Range - with built-in filtration 1501F & 3001F

These two models are an offshoot of our powerful CPF Series (page 6 & 7). They have slightly less styling and reduced comprehensive diagnostic features and are not programmable, but offer substantial initial draw off and excellent hourly output at a highly competitive price.

Both models feature built-in multi-functional filtration which can be adjusted to hard, medium and soft water.

Features and Benefits

- Basic fault self diagnosis with LCD read out
- Built-in multi-purpose filtration
- Electronic temperature control for constant temperature at around 97°C
- Easy access for service and cleaning
- Long-life incoloy elements
- Boil dry protection
- Stainless steel drip tray include
- 28 litres per hour output

Installation

Easy to install on a stable work top.

Plumbing

Designed for direct connection to a potable cold water supply using the 1.5 metre (3/4" BSP) hose supplied. An isolating valve should be installed between the supply and the heater. Rear supply connection and choice of rear (optional additional kit) or front overflow as standard.

Electrical

To be connected to 230 volt supply with a suitable break capacity of 13 amps.

Construction

Brushed stainless steel case.
Stainless steel heating chamber.
Low voltage switching.
2 safety cut-outs.

Technical Data

Model	Power Loading (kW)	Rapid Draw-Off		Hourly Output	
		(Litres)	(Cups)	(Litres)	(Cups)
1501F	3	10	60	27	162
3001F	3	15	90	27	162

Customer Service Tel: 01704 501114



NEW
FEATURES

ONE YEAR GUARANTEE
1
ONE YEAR GUARANTEE

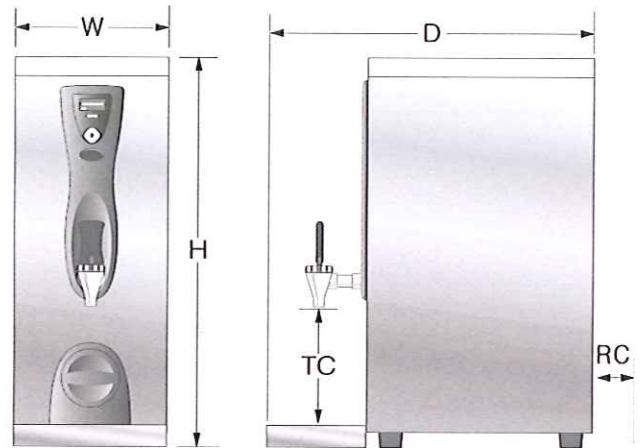

Dimensions

Model	Height (mm)	Width (mm)	Depth (mm)	Tap Clearance to Drip Tray (mm)	Rear Connection Clearance (mm)
1501F	610	252	360	190	50
3001F	618	310	360	190	50

Technical Help & Advice: 01704 502911