

## It began with the Pulmotor

The History of Mechanical Ventilation







## It began with the Pulmotor – The History of Mechanical Ventilation

Ernst Bahns

# Table of Contents

A History of More Than 100 Years	8
<b>The History of Ventilation Technology</b>	<b>10</b>
“Zero Hour” in Machine Ventilation: The “Original Pulmotor”	10
The Control Principle of the Original Pulmotor	12
Subsequent Development of the Pulmotor by Bernhard Dräger	14
From Prototype to the Production Line: A New Control Principle	16
The Pulmotor Principle (1)	18
The Pulmotor Principle (2)	20
The Pulmotor Dispute (1)	22
The Pulmotor Dispute (2)	24
Further Development of the Pulmotor: The Pulmotor Canister	26
The Pulmotor in Clinical Applications	28
A New Way: Alternating Pressure Ventilation with the Iron Lung	30
Creativity and Improvisation in the Post-War Period	32
The Beginning of Intensive Care Ventilation: Assistors	34
The Road to Modern Intensive Care Ventilation	36
Constant Progress in Intensive Care Ventilation: From the Spiromat to the EV-A	38
Modern Intensive Care Ventilation: The First Generations of the Evita Product Family	40
The New Generation of the Evita Product Family	42
A New Family in Dräger Ventilation: Savina	44
Non-invasive Ventilation with Carina	46
Ventilating Small Patients: The Road to Babylog	48
Intensive Care Ventilation in Neonatal Care: The Babylog 8000	50
From the Pulmotor to the Oxylog	52
The Oxylog® Series: The Road to Modern Emergency Ventilation	54
<b>The Role of Medical Staff</b>	<b>56</b>

<b>The History of Ventilation Technology</b>	<b>58</b>
The Ventilator in Clinical Applications: An Overview	58
Breathing and Ventilation Technique: The Fundamental Difference	60
Three Problems of Machine Ventilation	62
Pressure-Limited Ventilation with the UV-1	64
New Ventilation Technology with EV-A	66
Simple and Open for Spontaneous Breathing: Pressure Controlled BIPAP	68
Optimum Pressure and Open for Spontaneous Breathing: Constant-Volume AutoFlow	70
Pressure-supported Spontaneous Breathing	72
Adaptation of Support to Spontaneous Breathing	74
Regulation of Pressure Support by the Patient	76
The Issue of Connecting the Ventilator to the Patient	78
Specific Characteristics of Infant and Neonatal Ventilation	80
SmartCare®/PS	82
Trends in the Development of the Ventilation Modes: Conclusion	84
Tendencies in the Development of the Ventilation Modes: The Future	86
From Measuring Instrument to Ventilator Monitor	88
From a "Snapshot" to a Trend Analysis	90
The Value of Graphic Monitoring	92
Ventilation Monitoring in a New Era	94
Ventilation Diagnostics with New Images	96
Performance and Operation	98
High Performance, Easy to Use – A Contradiction?	100
Standardized Operation – A Vision?	102
From Ventilator to Ventilator Module	104
From Module to Acute Care System	106
Acute Care Seen as a Whole	108
Bibliography	110

## A History of More Than 100 Years

For Dräger, the history of ventilation is more than a sober chronological list – the history of ventilation is closely linked with the history of the Dräger family.

The history of ventilation for the Dräger company starts with the Pulmotor, for which my great-great-grandfather, Heinrich Dräger, received the patent in the year 1907. In his memoirs he describes how on a journey abroad he collected ideas for resuscitating people poisoned by gas and put these into practice in the shape of the Pulmotor. It was my great-grandfather, Bernhard Dräger, who helped prepare his father's invention for serial production and developed the concept of the Pulmotor controlled by airway pressure.

My forefathers must have been committed to ventilation heart and soul, not simply confining themselves to managing the company. They participated actively themselves in the development process. I, too, have inherited this enthusiasm for ventilation from my ancestors; I am a trained engineer and from 1999 to 2002 I managed the worldwide business sector for intensive care ventilation. Today's ventilators are controlled electronically by microprocessors.



However, the objective of this brochure is not simply to tell the history of ventilation, but we also want to contribute to the discussion about the future of ventilation. We want to describe ventilation to you in such a way that not only medical and technical experts will benefit, but everyone with an interest in the subject can gain an insight and be able to participate in the discussion about future trends in ventilation.

Having set ourselves the objective of bringing ventilation closer to people who do not deal with it on a daily basis, we have to explain some basics which others with a grounding in the matter will already know. For simplicity's sake, this booklet deals exclusively with ventilation within the Dräger company.



*Stefan Dräger*

Stefan Dräger

## “Zero Hour” in Machine Ventilation – The “Original Pulmotor”

Machine ventilation uses mechanical aids and oxygen to support insufficient spontaneous breathing. A ventilator ventilates the lungs with a ventilation pattern, a defined period of pressure and volume, thereby creating machine-supported breathing. Ventilators must be equipped with a control method and generally use oxygen for ventilation.

Hence two skills were required to develop ventilators. The designers had to know about control principles and they had to be familiar with pressure gases. Both prerequisites were fulfilled at the beginning of the last century in the still very young company of “Heinrich & Bernhard Dräger” and the development of a ventilator was a top priority in the truest sense of the word.

In his publication “The Development of the Pulmotor” (7) company founder Heinrich Dräger documented his ideas about developing a ventilator. He described a new technology for “blowing fresh air or oxygen into the lungs”. His Pulmotor created positive and negative airway pressure alternatively and was powered by oxygen under pressure. In 1907 Heinrich Dräger was awarded the patent for developing his “original Pulmotor”.

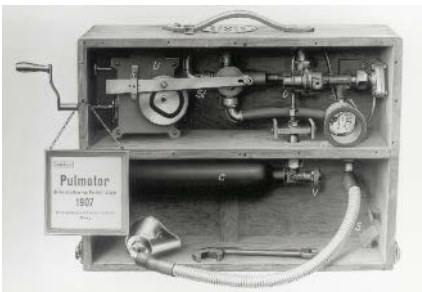

The original Pulmotor (1907). Prototype of the first Pulmotor that Heinrich Dräger patented



Heinrich Dräger receives his patent from the postman in the presence of his family

## The Control Principle of the Original Pulmotor

To switch between inhalation and exhalation, Heinrich Dräger used a mechanism in his original Pulmotor that he was very familiar with from his work as a skilled watchmaker. The ventilation pattern was controlled with a modified movement with a cam disc.



Bernhard and Heinrich Dräger

It is remarkable that Heinrich Dräger chose this control principle of the “Original Pulmotor”. He selected a technical principle which would replace nature as closely as possible. By setting the objective of imitating nature for artificial ventilation, he was way ahead of his time.

For Heinrich Dräger, the physiological function that needed to be replaced was the regular movement of the lungs with a constant time pattern. Therefore he selected a technical principle for his ventilator, guaranteeing a constant length of inhalation and exhalation during artificial ventilation. In modern terms, ventilation was time cycled.

The rest of the world, as well as those who continued to develop the Pulmotor further, followed another principle. Ventilation patterns were controlled by a technical principle which switched between inhalation and exhalation when a certain ventilation pressure was reached. These systems are pressure cycled. Pressure-cycled ventilation devices became more robust, more reliable and precise - in short - technically improved. Pressure-cycled ventilation devices seen from today’s point of view are technically optimized. They followed a path which at the time was more readily achievable technically.



Heinrich Dräger

Here Heinrich Dräger was – ahead of his time. Modern ventilators are not pressure cycled but are mostly time cycled. However, we do not know whether Heinrich Dräger knew then that his principle was closer to human physiology than others. The fact remains that his Pulmotor, patented in 1907, signposted the way with its timing control.

## Subsequent Development of the Pulmotor by Bernhard Dräger

The “Proto-Pulmotor” was certainly a ground-breaking concept but it remained on the level of a prototype that needed to be further developed for practical use. It had two faults which Heinrich Dräger recognized and documented during development (7). Firstly his construction caused considerable re-inhalation of exhaled gas. Secondary the breathing pattern could not be adapted to the patient due to the inflexible control of the movement. Heinrich Dräger left it to his son Bernhard and engineer Hans Schröder to find a remedy for these defects (8).



Bernhard Dräger (1904)

Bernhard Dräger solved the problem of re-inhalation of exhaled gas by redesigning the valve system that controls the flow of breathing gas to the patient. In the “original Pulmotor” the patient was connected to the ventilator only by a tube. This tube worked to a certain extent as an extension of the trachea since the inhalation and exhalation air was only separated inside the ventilator.

Bernhard Dräger replaced the connecting apparatus of the “original Pulmotor” with a tube system consisting of of an inhalation tube and exhalation tube. By altering the valve control, the patient’s inhaled and exhaled air could be separated thereby greatly reducing the exhaled carbon dioxide contamination of the inspiratory air.



Heinrich and Bernhard Dräger

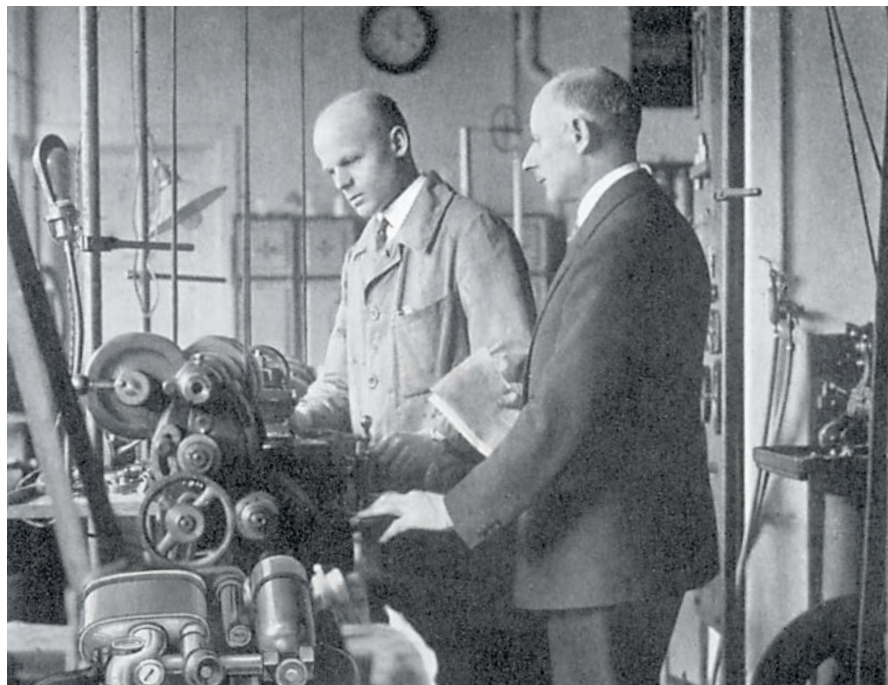

Bernhard Dräger in the test workshop

## From Prototype to the Production Line – A New Control Principle

Another great challenge in developing the original Pulmotor was the disadvantage of the rigid control system which could not be adapted to the patients' lung function. Dangerous ventilation pressures could arise, which are caused when the patient's lungs are deteriorated. Here the engineer Hans Schröder designed a construction using a control principle which would be used for several generations of ventilators. The newly designed control mechanism could be switched automatically from inhalation to exhalation depending on the pressure in the airways. A detailed description of the functional principle can be found on the following double page.



The Pulmotor in the medical car of a hospital on rails (1913)

The answer to the question which ventilator was actually the first depends on your point of view. If you define a ventilator as a machine which provides mechanically-supported breathing with a defined time pattern and offers the possibility of ventilation using oxygen, then the Pulmotor patented in 1907 by Heinrich Dräger was probably the first ventilator.

However, if you add the criteria of readiness for production and proven success in clinical use, then the development of the Pulmotor by Bernhart Dräger and Hans Schröder should be considered as the “first ventilator”. From this point of view the pressure-cycled Pulmotor was almost certainly the first ventilator worldwide in the history of medicine.



The Pulmotor used at a bathing accident





Serial production of the Pulmotor

## The Pulmotor Principle (1)

The Pulmotor was described in rough detail on the previous pages. Now follows more detailed description of the structure and function. The technical innovations of the Pulmotor are the “pressure and suction nozzle” to create the ventilation pressure and the control mechanism for switching between the inhalation and exhalation phases.

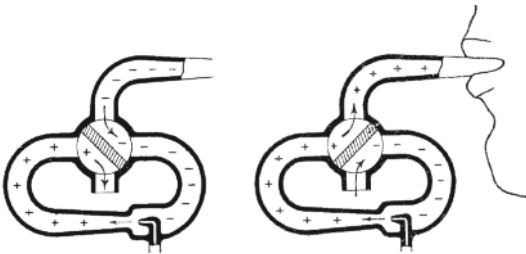

Heinrich Dräger's sketches of the original Pulmotor operational principle (7).

*Left: Expiration, right: Inspiration*

The energy needed for machine-supported ventilation came from the compressed gas cylinder of the Pulmotor, oxygen being not simply medicine for the patient but also the source of energy for the ventilator. The oxygen was mixed with ambient air and fed via a “suction nozzle” into a tube system. The construction

of the nozzle can be seen in Heinrich Dräger's diagram (7). When the compressed gas was fed in, gas flow was created in the tube system and positive pressure builds up in front of the nozzle and negative pressure after the nozzle. This type of construction is called an injector.

A valve system connected the patient during the inhalation phase to the positive pressure section in the tube system and in the exhalation phase with the negative pressure section. The approximate airway pressures of the original Pulmotor lay between +20 mbar in the inhalation phase and -20 mbar in the exhalation phase (7). The valve system for the original Pulmotor was a four-way cock which was activated by a movement as described above.

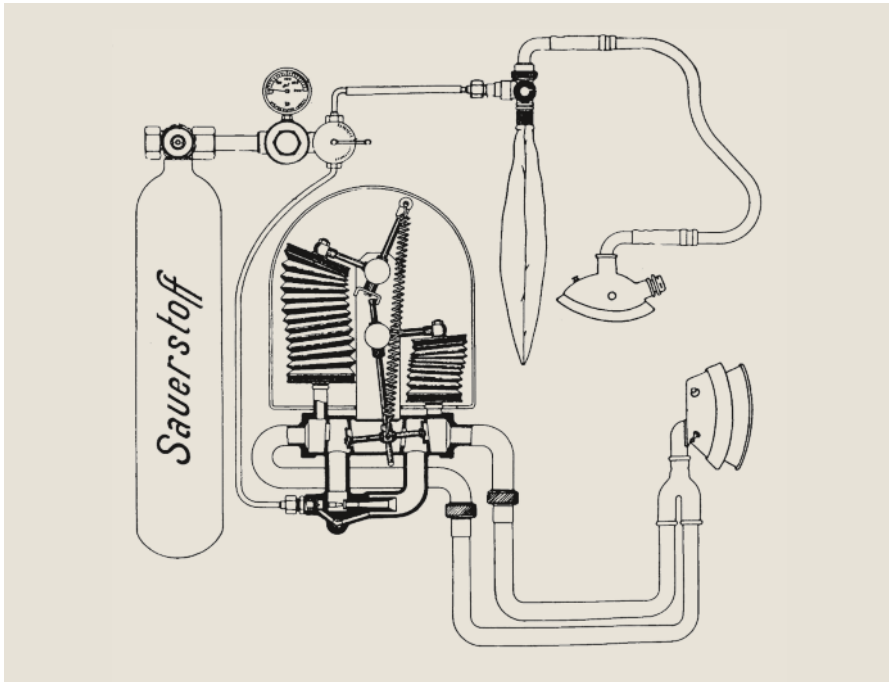

Schematic diagram of the pressure-cycled Pulmotor

## The Pulmotor Principle (2)

In its subsequent development, the injector principle of the original Pulmotor was retained by Hans Schröder. However, the four-way cock and the movement were replaced by a new control mechanism. (See the details of the construction in the diagram on the previous page)

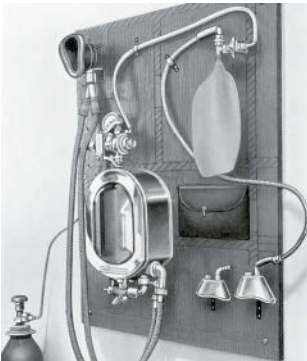

Pulmotor with wall bracket

The control mechanism consists of an inflatable leather bag which is connected to the tube system. This bag expands under positive pressure and activates a control mechanism. The control mechanism in turn activates a valve system which causes a change to the gas flow in the ventilation system. In the “ON” position the patient is connected to the positive pressure system and separated from the negative pressure system. In the “OFF” position the patient is separated from the positive pressure system and connected to the negative pressure system.

The valve system is still constructed such that the tube system is opened to ambient air during the exhalation phase so gas can flow out freely. A so-called braking bellows provides mechanical damping when switching between the ventilation phases.

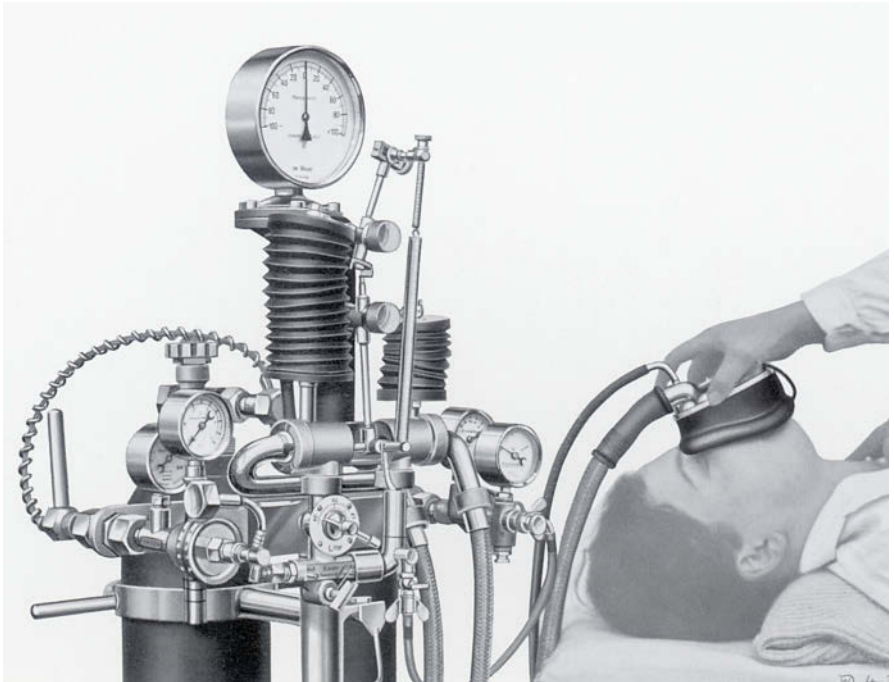

Pulmotor on tripod with additional device to add carbon dioxide to breathing air for use in the operating theater

## The Pulmotor Dispute (1)

Only five years after the start of production in 1908, 3,000 Pulmotors were in use – an enormous number at that time (22). Ten years later, the number of Pulmotors had doubled to almost 6,000 (12) and after 38 years the number was estimated at more than 12,000 (16). The resuscitations performed with the Pulmotor were documented with meticulous exactitude by Drägerwerk and published with great pride in the Dräger magazines (15).



Excerpt from the title page of a Dräger brochure in 1917

There was a very obvious interest behind this publicity activity by Dräger. They wanted to prove to the public that resuscitation via machine-supported ventilation was superior to a manual method. They defended themselves against criticism of the principle of high pressure ventilation used in the Pulmotor, a criticism which was levied by clinical users in the 1920s and came to a climax in the so-called “Pulmotor dispute” (13,14,16).

A Pulmotor, at the time, worked with a ventilation pressure of 20 cmH<sub>2</sub>O in the inhalation phase and a negative pressure of -25 cmH<sub>2</sub>O in the exhalation phase. To stimulate the respiratory center an admixture of CO<sub>2</sub> was used. This meant that, with the exception of the ventilation pressure in the inhalation phase, ventilation at the time differed considerably from methods today and the criticism of the clinic is at least understandable from today’s point of view. But the interesting thing is that the dispute concentrated mainly on the supposedly dangerous effects of the ventilation pressure on heart and lungs – the much more questionable negative pressures or the CO<sub>2</sub> admixture, as we know today, attracted very little interest.



Excerpt from the title page of the first edition of the Pulmotor News from 1929

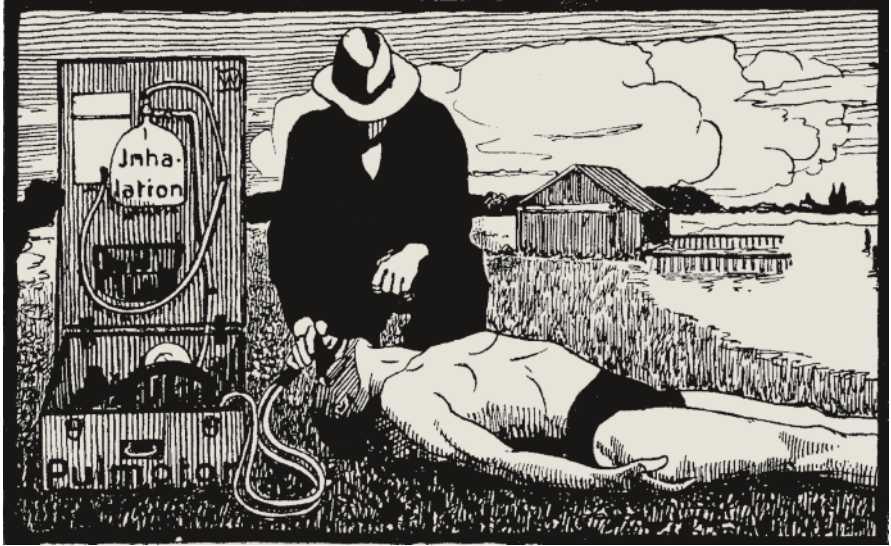

Use of the Pulmotor at a bathing accident – contemporary drawing from 1913

## The Pulmotor Dispute (2)

In 1922, the Department of Health as the then regulatory agency took the decision, based on the available knowledge, that there were no objections on health grounds to the application of positive pressure ventilation. However, it commissioned scientific investigations into the objections raised. As we know, these investigations into the subject of “Ventilator induced injury” have not come to a conclusion even today – so the “Pulmotor Dispute” is actually still relevant and the jury is still out.

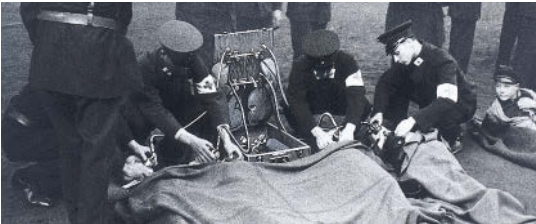

Pulmotor used to save lives

But the Pulmotor dispute is interesting not only from the historical point of view. Another factor adds to the interest, namely, the tactical and strategic behavior of Dräger in the Pulmotor dispute.

In the Dräger magazines of the period (12,13,14), we can read about the efforts Dräger undertook to dispel doubts about the efficacy of the Pulmotor and to counter conjectures about possible hazards. These efforts went far beyond simple commercial interests. The company wished to prove that they were doing the right thing.





Workers' Samaritan Federation from Schlitigheim (Alsace) after a Dräger gas protection course (1930)

So it was not just an issue of a product image, but rather a question of the company's good name. This was defended against all parties; customers, associations, regulatory agencies, and where appropriate, factual criticism was used as the impetus to technical development.

This strategy was more than “merchandising” as it was called at the time, today we would call it marketing.

## Further Development of the Pulmotor – The Pulmotor Canister

The Pulmotor principle with the switching mechanism using a bag, changed fundamentally in 1955 (11). Instead of controlling the breathing pattern via the double inflatable bag mechanism, a more manageable, smaller mechanism was introduced which was called the “Pulmotor canister” because of its casing.



Backpack Pulmotor PT 1

The switching mechanism in the Pulmotor canister was so small that it could be taken out of the basic unit and attached close to the patient’s body. The two corrugated tubes, which were not easy to handle and often became permeable over time, were now superfluous. The patient was attached to the new Pulmotor via a 1.5 meter long pressure tube which improved mobility considerably when using the new machine.

The spatial separation of Pulmotor canister and the basic device meant the Pulmotor could be used in many more applications and allowed for flexible use of accessories. For example, instead of the oxygen insufflation unit a further Pulmotor canister could be attached to the basic apparatus and, when necessary, two patients could be ventilated using one basic apparatus.

The ventilation pressures of the new Pulmotor were +15 mbar for inhalation and -10 mbar for exhalation. The enrichment in the inspiratory gas, which was available optionally in the previous models as a supposed simulation of the patient’s own breathing was no longer provided for the new Pulmotor. Instead, it was replaced by a pneumatically-driven suction device.



Case Pulmotor PK2

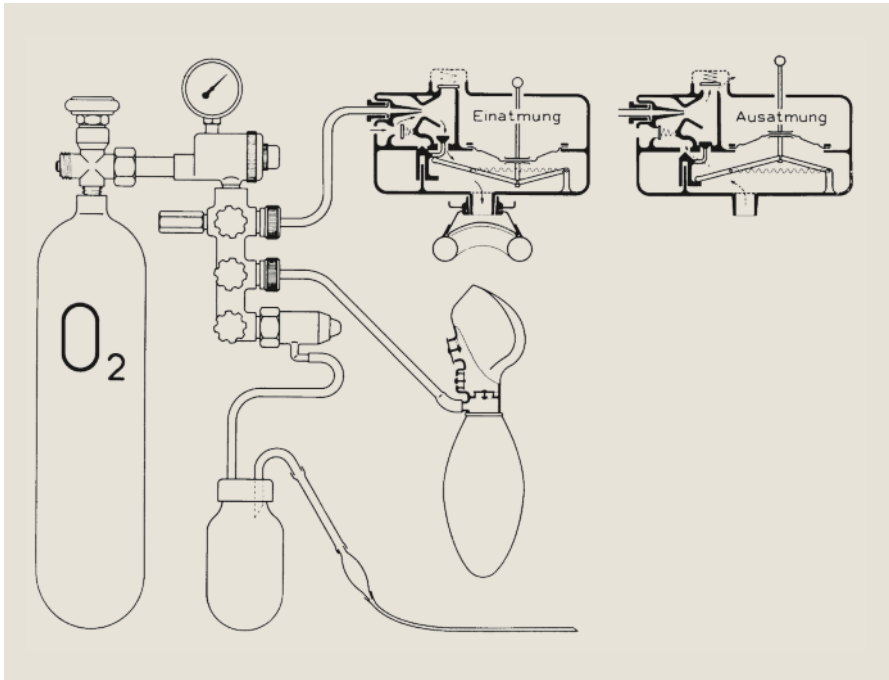

Schematic diagram of the switching mechanism of the Pulmotor canister:  
 inspiration phase and expiration phase

Apart from the standard case version, which was introduced as the PK2 model, the satchel version PT1 was also introduced. The latter weighed only 13 kg, slightly more than half the weight of the earlier cased version of the Pulmotor. The PK 60 and PT60 or PT61 models were enhanced models where a modified Pulmotor case provided pure oxygen ventilation without an intake of ambient air and for the first time made ventilation in a toxic atmosphere possible.

## The Pulmotor in Clinical Applications

For several decades the Pulmotor was an independent product series. Its main area of application was emergency resuscitation. In addition, the Pulmotor principle was used in various ventilation devices, mostly under another name.

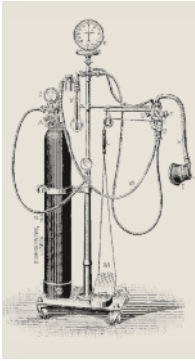

Lung Gymnastic Apparatus Type MSA for use in the operating theater (1913)

As early as 1910 the Pulmotor principle was used in the “Dräger Ventilator type MOA” fitted with a switching mechanism using a control bag and a simple airway gas humidifier. In 1913 the Lung Gymnastic Apparatus Type MSA followed, fitted with a pedal to switch between the inspiratory phases. A mobile version of the Pulmotor was available as early as the 1920s.

The most remarkable clinical version of the Pulmotor was the Poliomat which was fitted with the newly developed Pulmotor canister as early as 1953. In contrast to the Pulmotors, which were developed for short-term use, the inspiratory pressure in the Poliomat was not set in the factory but could be determined by the operator. In addition, inspiratory frequency and volume could be adjusted via control valves. Both the inspiratory pressure and the ventilated volume could be read from the instruments. The Poliometer was fitted with a inspiratory pressure meter and a volumeter.

For conditioning the airway gas, Dräger used a technique which was already used successfully for mine rescues. Nickel filter packages were used to humidify and warm the inspiratory gas. The humidity in the exhalation air condensed in the filters and this condensate was used to humidify the inspiratory gas in the inhalation phase.

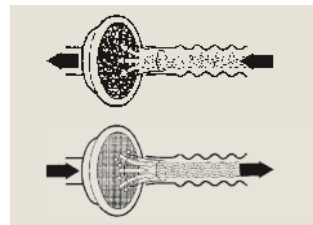

Operation of air moistener with nickel sieve



Portable Pulmotor on tripod with device for adding carbon dioxide (1928)

With the adjustment options for the inspiratory parameters, the measuring devices and the inspiratory gas conditioning, the Poliomat was fitted with the most important features of later intensive care ventilators. However, the Poliomat with its Pulmotor principle faced competition from other types of apparatus in the market to cover the enormous demand for ventilators after the Second World War.

## A New Way – Alternating Pressure Ventilation with the Iron Lung

The great demand for ventilators for clinical applications was caused primarily by the enormous increase in patients needing ventilation following the polio epidemics. The period shortly after the Second World War in particular saw a rise in the demand for ventilators which could ventilate patients over longer periods of time and in some cases were needed for lifelong use. Various devices for this application were developed which technically and operationally differed more or less from the Pulmotor.



Chest respirator (1956)

One of these devices was a large, rigid container into which the patient was placed. Such an apparatus was called somewhat erroneously an “iron lung”. However, the term “iron chest” would have been more accurate because the rigid container acted as a second thorax. A flexible diaphragm ensured continuous alternating pressure and ventilated the lung like an artificial diaphragm.

With the iron lung the survival rate increased markedly in cases of respiratory paralysis following polio. A disadvantage was the amount of space needed and the more difficult patient care.



Iron lung installed in an ambulance (1954)



Iron lung model E 52 with electric drive (1952)

A further development of the iron lung was the thoracic ventilator where alternating pressure was applied to the thorax only. Dyspnea in newborn babies is also treated in a negative pressure chamber that works on the same principle as the iron lung.

## Creativity and Improvisation in the Post-War Period

The conditions in which the first iron lungs were designed and manufactured at Dräger after the Second World War were initially very difficult. Using exceptionally simple resources and a great deal of improvisation, development was resumed at the end of the war (6). A torpedo tube was adapted to function as a pressure container for the prototype of the first iron lung. The bellows of a forge was used for the ventilation mechanism and the motor came from a fishing boat.

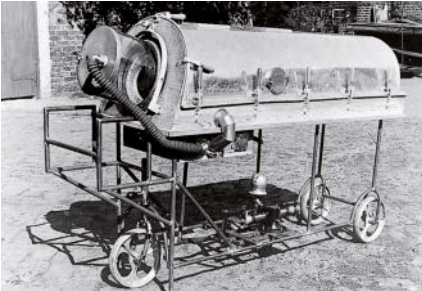

The first prototype of Iron Lung

The pioneers of the post-war period who pieced together the first iron lungs themselves found a partner in Dräger. With decades of experience in developing rescue devices for mining and diving applications, these engineers brought the concepts of alternating pressure ventilation to the production line.



Iron lung with water drive (1950)

The first iron lungs mass-produced by Dräger had a flexible diaphragm that could create ventilation pressures of +25 mbar to -25 mbar. These models were driven water. The iron lung E 52 was the first to be electrically driven.





Serial production of the iron lung at Dräger's factory

Iron lungs were in use for a short time only because a new thrust brought about a “renaissance” in positive pressure ventilation at the expense of alternating pressure ventilators. But this time the impetus did not come from the technical field but from clinical applications.

## The Beginning of Intensive Care Ventilation – Assistors

In the 1950s, a new perception in clinical investigation brought about a new attitude in ventilation therapy. Faulty treatment and complications were frequently caused because medical staff had to rely more on subjective clinical impressions when assessing ventilation rather than exact measuring parameters (5).

Without knowing the exact ventilation volumes administered, the set volumes could injure patients. Either patients suffered from inspiratory gas insufficiency or they were exposed to high stress by unnecessary intensive care ventilation.



Assistor Model 642 (1966)

New findings, in particular from Scandinavia, led to positive pressure ventilation with its superior ventilation control becoming important once more. Two lines of thought were followed: The first line was a further development of pressure cycled ventilation which in later versions was completed by measuring devices for ventilation volumes. In a second line new concepts were established with a setting of constant ventilation volumes.

For these new application areas, Dräger developed various ventilation apparatus which existed side by side for a time. In the field of pressure-cycled ventilation, the Assistor series developed further the successful principle of the Pulmotor (10).

A common characteristic of the Assistors, apart from pressure regulation, was the possibility to assist spontaneous breathing, i.e., the patients could initiate mechanical breaths with their own attempts at spontaneous breathing.

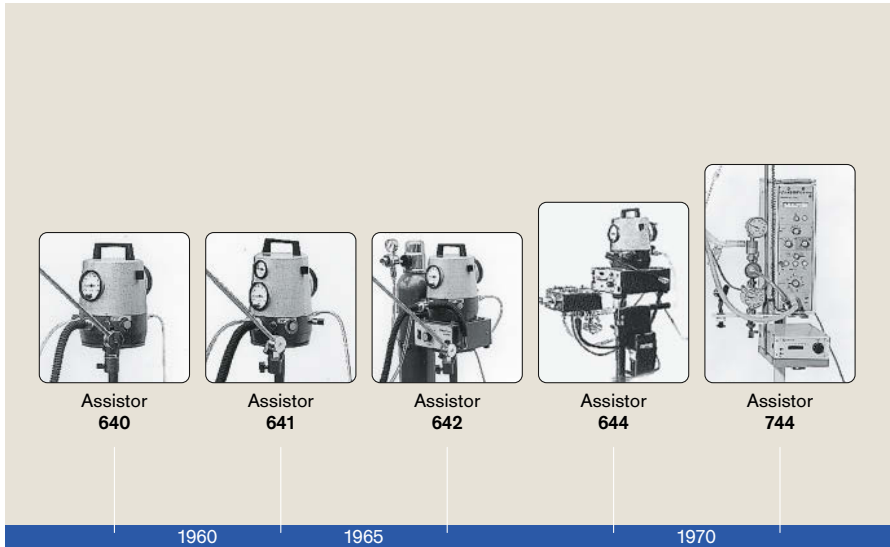

Assistor device range for **pressure-cycled** ventilation

The timer for delivering mechanical breaths on the Assistor 641 was pneumatically driven; in the Assistor 642, it was powered by electricity. With the Assistor 644, the length of use was extended with a new system of inspiratory gas conditioning and the circle of patients extended to pediatric applications. The Assistor 744 improved ventilation quality, in particular in pediatric applications, with a more sensitive trigger mechanism which meant easier activation of machine-assisted ventilation. Furthermore, the appearance of the early assistors, which took some getting used to, was improved. A user-friendly but esthetic product design was becoming increasingly important when developing medical equipment.

## The Road to Modern Intensive Care Ventilation

The assistants extended the area of application of ventilation considerably. In addition to ventilation for polio patients, post-operative ventilation and inhalation therapy for chronic lung disease became common. Despite the expansion of the range of applications, machine-assisted ventilation remained a relatively simple measure.



Spiromat in clinical use

However, modern ventilation goes one step further. It does not function simply as a bridge during a period of breathing insufficiency, rather it adapts the type of ventilation to the cause of the dysfunction and where possible treats the dysfunction in a targeted manner. Modern ventilation is respiratory therapy.

The requirements of targeted intensive therapy meant new demands on ventilators. In particular users were looking for control over the ventilation volume. Furthermore, the length of ventilation time should be variable by adjustable parameters and not simply be dependent on the lung mechanics of the patient. Time-cycled, constant-volume ventilation was required.

The first Dräger ventilation devices which fulfilled these requirements were the Spiromat series, introduced in 1955. They marked the starting point in the development of modern intensive ventilator equipment at Dräger.



Spiromat 661 with ventilation head E for long-term ventilation of adults



Ventilation of a patient after tracheotomy with the Spiromat 661

## Constant Progress in Intensive Care Ventilation – From the Spiromat to the EV-A

The next generation of ventilators were the UV-1 “Universal Ventilator” introduced in 1977 and the UV-2. They adopted conventional bag ventilation from the Spiromat, whereby the inspiratory gas is sucked out of a bag and pressed into the lungs. Control and monitoring of these devices was already performed electronically.

In 1982 the EV-A “Electronic Ventilator” introduced a completely new valve technology to Dräger ventilators. Electromagnetically actuated valves allowed the inspiratory gas flow and the inspiratory pressure to be controlled precisely and rapidly even during a breath. Microcomputers were able to create ventilation patterns which were unthinkable with the previous generation of equipment.



Intensive ventilation with UV-1.  
The movement of the ventilation bellows is observed by the user to detect breathing phases

In addition, the EV-A series was the first to offer graphic monitoring of ventilation. Ventilation curves, numeric data and text messages could all be displayed on a screen integrated into the ventilation device. Since then graphic monitoring on an integrated screen has been a standard feature of Dräger intensive care ventilation devices. This integrated graphic monitoring was introduced by other manufacturers 15 years later and from that date became part of the basic configuration of intensive care ventilation equipment.



Intensive ventilation with EV-A. Depiction of the ventilation curves on the integrated screen

## Modern Intensive Care Ventilation – The First Generations of the Evita Product Family



Evita 2. Conventional operation with knobs, graphical depiction and text messages on the screen



Evita 4. Modern operation via touch screen and complex graphics on the screen

The introduction of the Evita series in 1985 saw further developments in computer technology applied to ventilation and enabled machine-assisted ventilation to be adapted even closer to spontaneous breathing. New performance characteristics of the Evita series were made possible by the rapid development of screen technology. Higher graphics resolution and color displays ensured improved information transfer via image and text. And progress in screen technology was not limited to displays. The Evita 4 used a touch-sensitive screen for the first time when it was introduced in 1995. This touch screen technology practically revolutionized the concept of functionality in ventilation terms.

On its market launch, the Evita 4 had an enormous number of new features in therapy, monitoring and operation and therefore met the rising demands of critical care ventilation. The market for ventilators, however, not only became more demanding but also more differentiated: Not all customers wanted the best system available, some wanted to concentrate on limited functions and others wanted more and more. For some time, Dräger not only focused on “the market” which traditionally had always been the domestic market, but now, Dräger was also increasingly concentrating on export markets with their different requirements. For this reason, parallel product lines were introduced – Evita grew to become the Evita product family.



First came the Evita 2 *dura* in 1997 with a limited performance range compared to the Evita 4. The EvitaXL was introduced in 2003 with a markedly greater range than the Evita 4. However, the three members of the Evita product family are differentiated not only in their scope of performance but also in their innovation cycle, with the EvitaXL leading the way. After their launch, innovations such as the automated weaning programme SmartCare as well as the measuring manoeuvre Low-Flow-Loop remained an exclusive feature of the EvitaXL.



EvitaXL. Freely configurable integrated monitoring and operation on a color screen with touch-screen technology

## The New Generation of the Evita Product Family

In 2014, a generational change took place at Dräger critical care ventilation. In 2007, Dräger had already presented a module within an acute care device system called V500. Shortly afterwards, this module lay the cornerstone of the new Evita product family under the name Evita V500. The Evita V500 uses a fundamentally new technology for breathing gas dosing, has new hardware and software in data management as well as a modern design and had therefore only little in common with the last generation based on the Evita 4, with which it was a part of the product range of Dräger critical care ventilation in parallel for a few years. The new technology allows the integration of features that were previously only possible as additional components, such as the SmartCare/PS mentioned above. And there is still extensive room for future innovations. It is therefore more future-proof compared to the previous generation, which, with regard to future extensions, had reached its technological limit.



Evita V500

One thing, however, remains conservative: It keeps the proven operating concept of the Evita and users therefore do not have to adapt to a new operating philosophy. The Evita V500 also maintains another feature: It's the name Evita, which has by now become a synonym for successful Dräger ventilation.



Evita V300

In 2013, the Evita V500 got a "little sister". Even though they essentially use the same hardware, the difference between Evita V300 and her big sister is that the features can be chosen freely. This way, fewer features can be selected when the V300 is first purchased, and can later, if required, be upgraded to a level similar to that of the Evita V500.

## A New Family in Dräger Ventilation: Savina

Parallel to the Evita series, a range of ventilation devices was developed at the end of the previous century where costly inhalation valves were replaced with an alternative robust technology to service the needs of developing and emerging countries. Instead of the expensive technology of electromagnetically actuated valves which require good quality pressure gas for their operation, a turbine was used which only requires ambient air to function. The Savina was introduced in 2000 as the first Dräger ventilator to use this turbine technology.



In 2000, the technology of breathing gas dosing by using compressors already fulfils high demands for ventilation quality and in some cases even exceeds them. This especially applies for spontaneous breathing during mechanical ventilation. However, in the area of graphic monitoring, further developments were necessary to meet this higher standard.

Ventilation with a breathing gas compressor brought another advantage. Since it ventilates with ambient air, Savina is especially useful for intra hospital transport, as it works independent of a central gas supply. In addition, it features its own power supply for network-independent operation lasting several hours.

With the launch of the Savina 300 in 2010, Dräger introduced high-resolution graphic monitoring on a larger screen, operated via touch screen. With a further development in 2013, the Savina 300 then added capnography as well as various graphic representations in the form of loops and trends and easy diagnostic methods. It was therefore on the same level as the Evita 4 or even exceeded it, not only when it came to breathing gas dosing but also with regard to monitoring and its operating concept.



Savina 300 – critical care ventilation with ambient air, independent of central gas supply

## Non-invasive Ventilation with Carina

In industrial countries, the fields of application for ventilators became more and more differentiated and new areas were added to the classical emergency and critical care ventilation.

The original critical care therapy was designed for maximum medical care for patients with serious diseases. This was the basis for new devices developing in the clinical and outpatient fields requiring less monitoring and therapy in ventilation.

In outpatient care, the area of home care was developed, where ventilators are used meeting specific, mostly lower requirements than those used for classical intensive care treatment. Home care ventilators are not only operated by qualified medical professionals, but also by laymen for some functions.

Apart from the classical intensive care treatment, the area of sub-acute care developed in hospitals in Anglo-American regions toward the end of the last century. In this area as well, more cost-effective ventilators with fewer ventilation procedure and monitoring functions were demanded.



Carina (left) and Carinahome (right). Ventilator in sub-acute care and home care

For these two segments, Dräger developed the product family Carina, for home care and later for the area of sub-acute care. The home ventilator Carina home was mostly offered on the German market until 2008.

After withdrawing from the home ventilation market, Dräger started to promote the Carina exclusively for the area of sub-acute care.

Carina offers all standard methods of pressure and volume-controlled ventilation as well as pressure-supporting spontaneous breathing. If required,

Carina can even be used for invasive ventilation. Thanks to its breathing gas compressor, which, similar to the Savina, works with a ventilator, it allows spontaneous breathing with low breathing effort.



Carina – non-invasive ventilation with a handy and easy-to-use device

For monitoring the ventilated patient, Carina is equipped with a colour screen that shows two ventilation curves, measured values and alarm signals. Just like any modern devices of Dräger acute care, it is operated by means of the standard knob and text messages on the screen.

Carina therefore fulfils all requirements necessary for ventilating a patient with a stable and non-critical course of disease. In addition, Carina has an advantage that intensive care ventilators with more equipment do not have: Due to its low weight of 5.5 kg, it can easily be carried with one hand.

## Ventilating Small Patients – The Road to Babylog

Ventilating infants and newborn babies makes special demands on ventilation technology which cannot be met partially by equipment designed for adults. The specific challenges of neonatal ventilation are smaller inspiratory volumes, faster changes in the gas flow and more particularly protection against too high airway pressures and too large mandatory breath volumes. Initially neonatal ventilators were simply modified adult ventilators.

The first Dräger ventilator for infants was the Baby Pulmotor, a modification of the original Pulmotor (23). The ventilation phases were switched via a four-way valve which was not triggered by a movement but manually. The subsequent generations of the Pulmotor pediatric versions were developed primarily for first aid in delivery rooms.

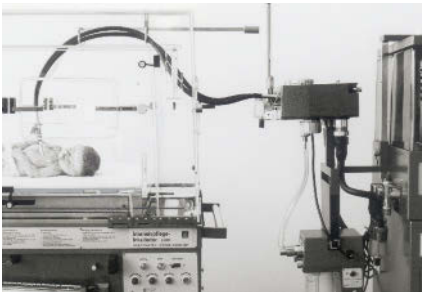

Modified Spiromat for ventilation of small children

Until the 1970s Dräger developed versions for neonatal care in parallel to the adult ventilators such as the neonatal version of the Spiromat 1958 and the Assistor 644 from 1965.





Babylog 1 for use in neonatal clinics. Additional modules connect to the ventilation device for setting the oxygen concentration and monitoring breathing pressure

A specialization in neonatal ventilators began in 1975 with the Babylog 1 and continued with the Babylog 2 in 1979 as a variation for ventilation during transport. A highly simplified version of the latter was developed for high frequency ventilation. Even though these ventilators were developed with many components from adult ventilators, nevertheless they were adapted very closely to the needs of newborn babies. A ventilator was not developed specifically for neonatal care until the end of the 1980s.

## Intensive Care Ventilation in Neonatal Care – The Babylog 8000

The first ventilator designed exclusively for pediatric and neonatal care was the Babylog 8000, introduced in 1980. Almost everything was new in this product in comparison to earlier devices. Instead of one valve for dosing a type of gas, the gas was delivered via numerous digitally-activated valves. This meant that very rapid changes in gas flow and the high dynamic range typical of neonatal ventilation could be achieved.



Babylog 8000. Integrated graphic monitoring with a real-time flow curve in the SIMV procedure. Above the device: real-time flow curve in high-frequency ventilation

The Babylog 8000 was first to introduce flow measurement for ventilating infants and the measuring unit was located close to the patient's body. The measuring accuracy was so high that it could not only be used for monitoring but also for regulating the ventilation volume. Patient-related flow measurement provided sensitive triggering combined with the greatest possible protection against erroneous triggering. In addition the Babylog was equipped with a graphics screen – also an innovation in neonatal ventilation.

Seldom has a ventilation apparatus led to such far reaching changes in clinical practice as did the Babylog 8000. With its introduction premature babies could be ventilated on a volume-oriented basis for the first time because the volume was metered and measured exactly. The sensitive triggering method and automatic compensation for leakages, which are normally unavoidable in neonatal ventilation, enabled a degree of gentle ventilation unknown until then.

The Babylog 8000 with the new concept of volume-oriented ventilation of premature babies has become the standard on many infant intensive care units around the world.

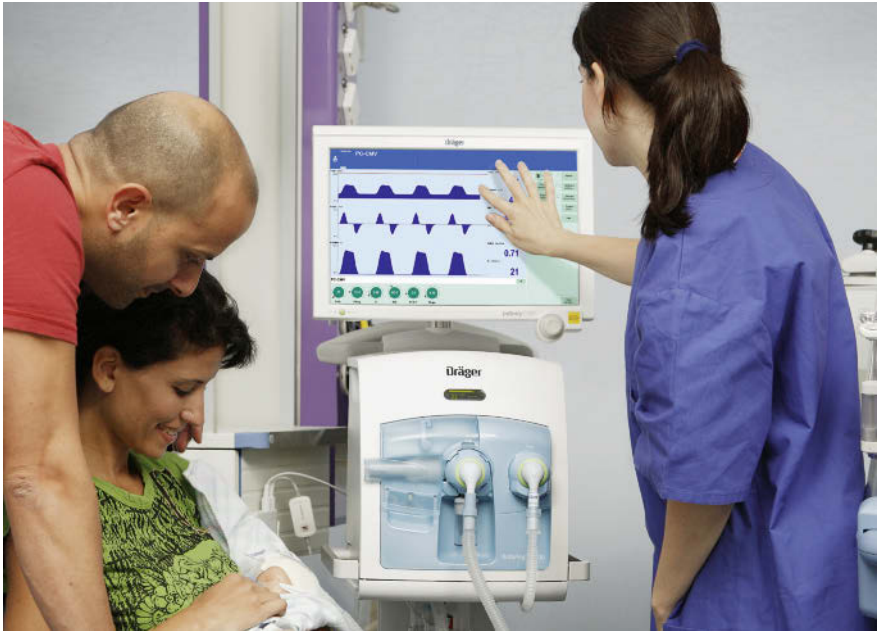

Babylog VN500 – Intensive care ventilation on the premature baby ward.

With the launch of the Babylog VN500 in 2009, Dräger brought the ventilation of premature babies, with regard to operation and monitoring, to the same high standard that had been established for adult ventilation years earlier. With the new device concept, Dräger introduced touch screen operation as well as extensive graphics on a large colour screen for the ventilation of premature babies. The ventilation procedures were also further developed and high-frequency ventilation was added.

## From the Pulmotor to the Oxylog

The limits of pressure-assisted ventilation in intensive care ventilation had been recognized in the 1950s and had led to the development of the time-cycled constant-volume ventilators. This development did not reach the field of emergency ventilation until two decades later. At Dräger it led to the development of a completely new emergency ventilation device launched in 1976 under the name of Oxylog®.



The first version of the Oxylog® ventilation device. Constant volume ventilation in emergency medicine

The operational system was completely new compared to the Pulmotor. Instead of the pressure-cycled switching mechanism, a pneumatic logical control was used. The new pneumatics not any more delivered constant flow which could be directed to the patient or into the ambient atmosphere; it also delivered the inspiratory gas only during the inhalation phase and discontinued the flow during the exhalation phase, thus creating an intermittent flow. This principle is called a “flow chopper”.

Using this new operational principle time-cycled constant-volume ventilation was now possible in emergency medicine. The minute volume could now be adjusted directly on the device and it remains constant during ventilation, ensuring guaranteed ventilation required by users. Ventilation frequency could also be adjusted freely on the device and hence ventilation adjusted to heart resuscitation. The frequency also remained constant throughout use and did not have to be adjusted when the oxygen concentration was changed, in contrast to the Pulmotor. Stenoses could be recognized directly on a ventilation pressure gauge – whereas the Pulmotor users had to rely on someone interpreting the quick switch and the “rattle” correctly. In addition, the control unit used barely one liter of pressurized gas per minute, a considerable savings, compared to the Pulmotor.



Emergency ventilation with the Oxylog®. Ventilation device, oxygen bottle, pressure reducer and accessories are stored in the backpack similar to the backpack Pulmotor

Given all these advantages the Oxylog should have rapidly displaced the Pulmotor on the market – but things turned out very differently. A conversion kit gave customers with a PT60/61 or a PK 60 the possibility to replace the Pulmotor canister with an Oxylog. This meant that customers buying a new Oxylog could continue to use the accessories of the Pulmotor such as the satchel and the oxygen bottle. This led to a long transition period lasting several years when the Oxylog was used in conjunction with Pulmotor logistics.

## The Oxylog® Series – The Road to Modern Emergency Ventilation

The Oxylog was designed for first aid applications and its primary purpose was to maintain vital functions via machine ventilation. Its application concentrated on first aid situations and the subsequent transport of patients for treatment in hospital, so-called primary transport. Therefore the performance features were limited to purely controlled ventilation and for monitoring, a simple manometer for measuring the airway pressure was used.



Oxylog® 2000

But the requirements for emergency ventilation increased also and further fields of application for the Oxylog developed such as the secondary transport or transport during treatment in hospital, for example when a patient is moved to another ward. To meet this need in 1993 the Oxylog 2000 was introduced. This enabled spontaneous breathing by the patient in addition to controlled ventilation. It was fitted with extensive monitoring features for monitoring the airway pressure and ventilation volume. Readings and text alerts could be read for the first time in emergency situations on a screen and alarms alerted personnel to potentially life-threatening conditions. All settings for the Oxylog 2000 could be made directly on the basic unit, thus removing the need for separate adjustments of valves.



Oxylog® 1000

In 1997 the Oxylog 1000, the successor to the Oxylog first introduced in 1975, was launched. With the Oxylog 1000 the gas supply and the airway pressure in the patient could be monitored. In 2003 another member of the Oxylog product family was born: the Oxylog 3000, with its new ventilation options and an integrated graphics display, introduced a quality of treatment to emergency ventilation which previously had only been available in intensive care ventilation. Varying transport solutions for all three models in the Oxylog series were developed such as the carrier systems and the caddy for accessories.

One and a half decades after its introduction, the Oxylog 2000 got a successor: The Oxylog 2000 plus, that is based on the technology of the proven Oxylog 3000, was launched in 2008. One year later, the Oxylog 3000 plus enhanced emergency ventilation with new features such as AutoFlow and integrated capnography.





Oxylog® 3000. Graphical monitoring and ventilation procedure meets the demands of acute medicine

After the history of emergency medicine we will now take a different look at one hundred years of machine ventilation. Using detailed descriptions of the different models and designs we have shown how the different generations of ventilation equipment developed.

After this emphasis on technical issues, we now want to ask the question “What has changed as a result of these technological developments?” Let us start with the users by looking at the question of how the role of doctors and care personnel has changed during the hundred years of ventilation.

## The Role of Medical Staff

In summary, the history of ventilators as described above can be divided roughly into three phases: Firstly, simple machine ventilation, secondly ventilation optimized by manual corrections made by medical staff and thirdly, ventilation with automatic adjustment to the patient.

The Pulmotor, Assistors and the first constant-volume ventilators are simple machines in today's understanding. The primary goal of ventilation was to ensure ventilation of lungs during use. Medical staff had only a few possibilities of adjusting the machine and only modest safety devices, for example against excessive ventilation pressure.

With the introduction of the UV-1 the role of medical staff began to change: From now on they were not only responsible for simply setting the basic parameters, they could adapt ventilation to the patient in a targeted manner. Furthermore they were able to prepare the patient for independent breathing by a gradual, conscious reduction of machine ventilation and hence wean the patient from the machine. Furthermore they were able to optimize the inspiratory pressure, for example, and at the same time maintain the volume at a constant level. However, these new possibilities required a great deal of work in their medical applications which benefited the patient only in part. A large part of the additional work consisted in manual corrections of the shortcomings of ventilation technology at the time.

The new possibilities offered by an automatic adjustment of the ventilator to the physiological condition of the patient started to change the role of clinicians: They were released from their roles as "machine operators."

Automatic adaptation to the patient was limited initially to mechanical changes to the lung: For example, the EV-A was able to ventilate in the case of a fistula even when a leak occurred. The Evita model offered improved adaptation of ventilation to the patient's breathing by subjugating machine ventilation to physiological ventilation and allowing spontaneous breathing during machine ventilation.



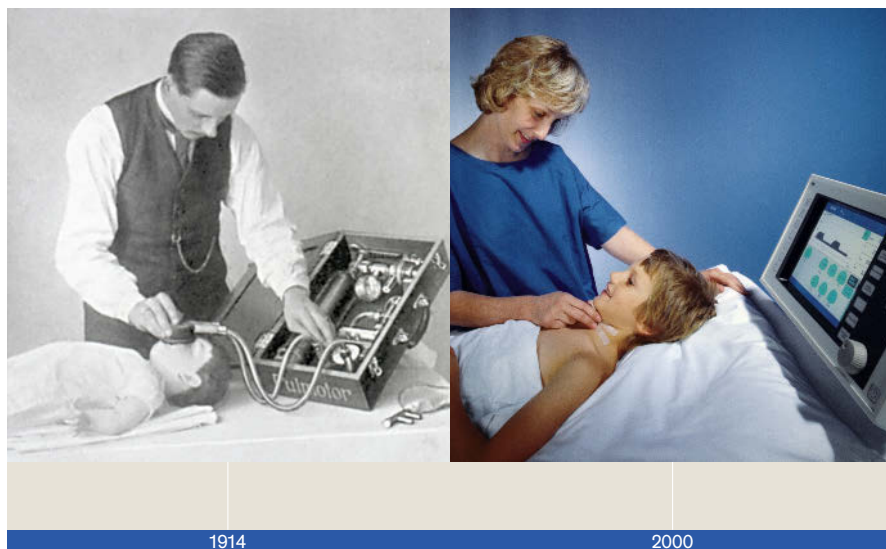

Ventilation of children at the beginning and end of the first century of ventilation. Pressure removed from user due to automation. *Left:* Baby Pulmotor – the user switches the breathing phases manually. *Right:* Evita 4 – the ventilation device adapts automatically to the lung mechanics and the staff can care more for the patient

It had become necessary to relieve clinicians of the burden of acting as machine operators because modern ventilation allowed for treatment of very severe disease patterns which required more time to treat the patient.

During the years the role of clinicians has changed less as a result of ventilator technology and more as a result of what the ventilators can do and the corresponding benefits for patients. The use of a ventilator can be divided into treatment, monitoring and operation and we will take a closer look at these phases below. The historical development of the ventilation modes, ventilation monitoring and operating modes will be dealt with primarily from the point of view of the benefits to the user and to the patient.

## The Ventilator in Clinical Applications – An Overview

In ventilation technology we describe the course of pressure and volume as ventilation patterns. In contrast a ventilation mode describes the interaction between patient and ventilator. When developing ventilation modes the initial emphasis was on resuscitation when the patient's breathing stopped. The first ventilation devices were emergency ventilation devices where a short-term bridge was the primary concern when the patient's own breathing stopped. However, the life-saving ventilation techniques put such a strain on the lungs when used over time that it was difficult to return patients to normal breathing.

An adaptation of ventilation techniques to the physiology and less stressful ventilation was initially achieved using auxiliary devices which limited the damaging effects of ventilation and trained specialists could use in a targeted manner. Ventilation techniques which ensure automatic adaptation of ventilation to the patient have been developed only recently.



Monitoring devices on an Evita 2.  
The numerical values next to the graphics screen are ordered by priority

The surveillance devices for ventilation are termed ventilation monitoring. With the first ventilators this was limited to measurement of the airway pressure and simple function checks of the equipment. Not until the advent of electronics and microcomputers could more complex situations be dealt with. Thereafter monitoring functions became increasingly an integral part of ventilators. The advances in the quality of displaying information from a simple reading to screen display are the most striking development.

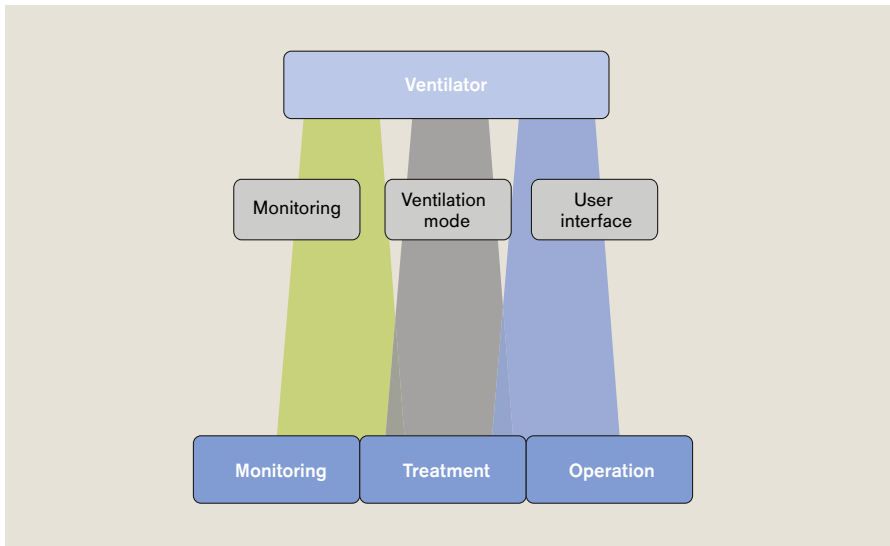

Structure of a ventilation device. Functions (center) and related activities (bottom) in ventilation

All the elements needed to operate a ventilator are called the user interface. With the increasing complexity of ventilation functionality, operating the equipment has become more complicated. The number of operating elements has increased steadily. Qualitative progress has been achieved only recently. Using a screen interface to set functions increases the performance range of the machine while simplifying its operation.

## Breathing and Ventilation Technique – The Fundamental Difference

For several decades adequate ventilation of the lungs was the primary goal of ventilation. Not until the 1970s did a change of attitude occur and ventilation techniques were established based on avoiding damage to lungs. There is a good reason for the late development of a patient-oriented ventilation. There is a fundamental difference between machine ventilation and physiological breathing. Ventilation is not simulation of breathing, rather it is a substitute with unavoidable side effects due to the principle which people were not aware of earlier. In addition the activation and adaptation of the inspiratory gas flow in ventilation was a great technological challenge which was quite simply beyond the capabilities of older ventilators.

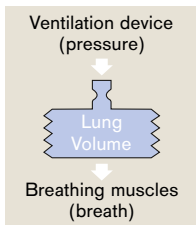

Principle of  
ventilation

The fundamental difference between physiological breathing and artificial ventilation can be seen in the inhalation phase. In breathing the inner volume of the chest is increased by contracting the respiratory muscles. This causes a negative pressure in the lungs and air is sucked in. In contrast, in ventilation the reverse principle takes effect. The ventilator creates positive pressure and hence presses inspiratory gas into the lungs. The ventilation pressure can affect the lungs and other organs during this process. One of the greatest challenges of artificial ventilation today is to keep

the side effects of ventilation pressure, which are basically unavoidable, as low as possible (2,4). Now we will explain the techniques for avoiding side effects in a simplified fashion.

The most important functional elements of a ventilator is the device for dosing the gas and the exhalation valve. A control unit ensures that the inspiratory gas is pressed into the lungs of the patient during the inhalation phase and that the gas flows out via the exhalation valve during the exhalation phase. The control unit switches the gas dosing function on during the inhalation phase and closes the exhalation valve. The pressure created acts like a bellows to ventilate the lung. During the exhalation phase no inspiratory gas is fed in under normal conditions since the inspiratory gas escapes from the lungs automatically via the opened exhalation valve.

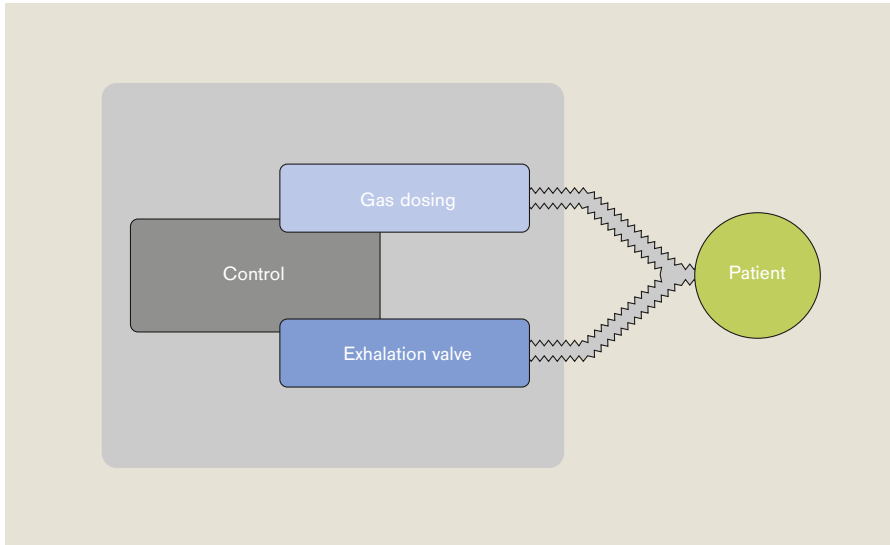

Functional elements of a ventilation device

This is the fundamental operating principle of most ventilators. However, the quality of inspiratory gas dosing in older machines differs considerably from that of modern ventilators. In the first ventilators it was the machine which determined the time constant for the inspiratory gas supply. If an imbalance occurred between the patient's breathing and the machine ventilation, the only remedy was to sedate the patient with drugs.

Hence the first ventilators were “miles away” from the physiology of breathing. Characteristic of the progress in the development of ventilation techniques is the constant reduction of this gap through technical and medical developments.

## Three Problems of Machine Ventilation

The adaptation of time-cycled machine ventilation to physiological breathing was not solved in one go but happened in a number of stages. Each stage marked the solution of one of the problems caused by the reversal of the pressure conditions and technical limitations.

Here we describe the three main problems which can be identified from the ventilation pattern. A ventilation pattern can be displayed as ventilation curves. Such curves are drawn when the airway pressure or the inspiratory gas flow is recorded for the length of an inhalation or exhalation. The time interval from the beginning of an inhalation to the start of the next is called the ventilation cycle.

The diagram shows the ventilation cycle of a Spiromat from 1955 as an airway pressure and flow curve. The progress of the airway pressure clearly shows the three phases. The pressure rises initially in Phase 1 to a peak value. This phase is called the flow time. In Phase 2 the pressure drops to a stable value and is therefore described as a plateau. In Phase 3, the exhalation time, the pressure drops to a terminal value.

The time constant for the inspiratory gas flow (flow) shows the three phases even more clearly. The three problems can be explained with the ventilation curves shown on the next page.

Initially pressure peaks can be created at the start of inhalation due to the constant inspiratory gas flow. Under certain circumstances the lung tissue can be exposed to a high mechanical strain. Secondly, exhalation is not possible during the plateau because the ventilator still keeps the exhalation valve firmly closed. Natural breathing is disrupted considerably during this phase.

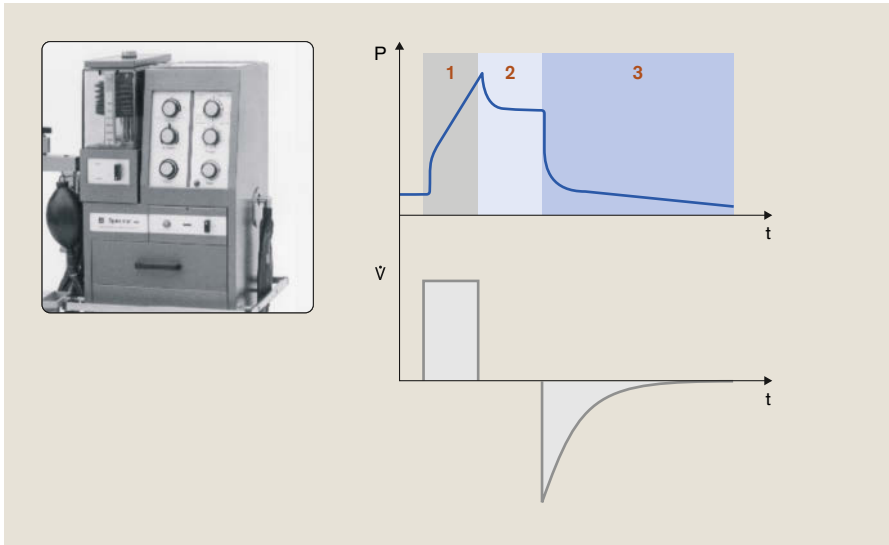

Ventilation curves from a Spiromat. Top: Pressure curve, bottom: Flow curve. Sub-division of a ventilation cycle into the flow phase (1), plateau phase (2), and expiration phase (3)

Thirdly, the terminal pressure drops if inspiratory gas can escape through a leak. However, a constant terminal pressure is very important in clinical terms and so has been given a name. The airway pressure at the end of the exhalation time is called PEEP\*.

The solutions for the three problems were developed at different times. The first problem to be tackled was the pressure peaks.

\*PEEP = Positive End Expiratory Pressure

## Pressure-Limited Ventilation with the UV-1

Pressure peaks at the beginning of the inhalation phase arise during machine ventilation as a result of a very simple form of inspiratory gas dosage as used in the first Spiromats. The inspiratory gas is administered with a constant flow without taking into account the airway pressure created. This type of ventilation can result in pressure peaks in the lung due to physical laws. Only when the inspiratory gas spreads throughout the lungs does the pressure revert to the plateau value.

Anesthetists recognize this problem. They avoid pressure peaks in manual bag ventilation by skillful control of the ventilation pressure. They carefully manipulate the ventilation bag to avoid overextending the lungs at any time with too high an airway pressure. With machine ventilation the problem of pressure peaks was solved with a technical solution which copies the hand of the experienced anesthetist to a certain extent. The principle is that of inflatable bag ventilation with an adjustable working pressure which was used in the UV-1.

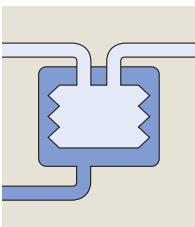

The principle of machine-based bellows ventilation  
Notes: see text

The construction of the ventilation bag as illustrated in the diagram. The ventilation bag is placed in a rigid container and the pressure in this container is set by clinicians as the working pressure. This construction enables ventilation where the airway pressure is limited to the value of the working pressure. This type of modified constant-volume ventilation is called “pressure-limited” ventilation.

The diagram on the next page shows the curve for pressure-limited ventilation. The pressure peak is “cut off” here and the flow drops continuously from an initially constant value. Such a drop in flow in pressure-limited ventilation is called “decelerating flow”. If the pressure is reduced to the extent that the preset breath volume is not reached, ventilation then becomes very similar to “pressure controlled”. In pure pressure controlled ventilation breath delivery is determined by setting of pressure only and no volume is set any more.



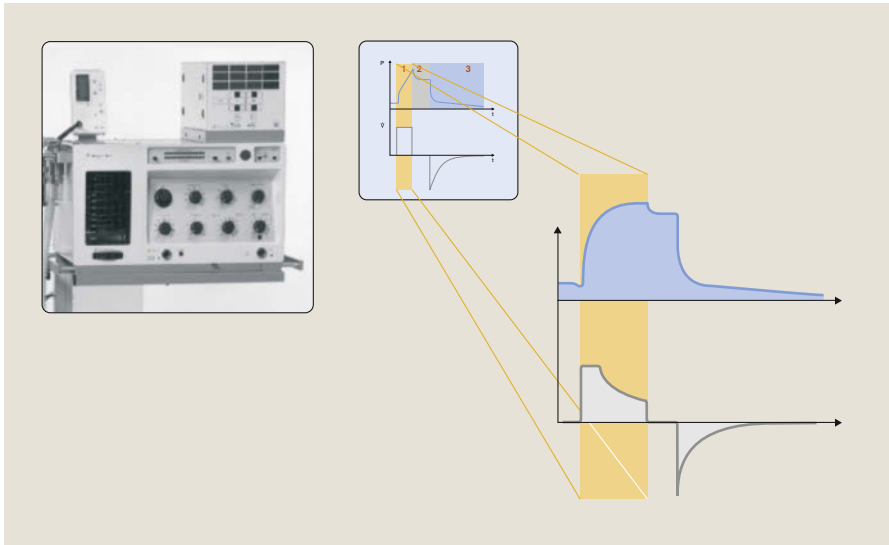

Ventilation curves from a UV-1. Pressure-controlled ventilation derived from the constant volume ventilation by limiting the pressure

The concept of pressure-controlled ventilation in the UV-1 and the subsequent models differs fundamentally in this point from all other ventilation solutions. Pressure-controlled ventilation was not introduced as a new independent mode but was derived from a constant-volume ventilation mode. Pressure-controlled ventilation should not be considered the successor to constant-volume ventilation. Both processes were available at the same time. Both modes were available at the same time. For a long time, the UV-1 and its later models were the only ventilators which offered a combination of the advantages of both types of ventilation.

## New Ventilation Technology with EV-A

Conventional pressure-controlled ventilation did not make any additional demands on ventilator technology. It could be carried out with a thoroughly satisfactory quality with the bag ventilation used earlier.

The bag ventilation principle was superseded in the 1980s by microprocessor controlled ventilators and Dräger was among the first manufacturers with its EV-A. Initially the new ventilator generation did not achieve any significant solutions to the problems of conventional modes but rather copied the established ventilation types with a new technology for inspiratory gas dosage and control mechanism of the exhalation valve.

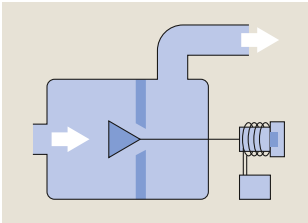

Functional drawing of an electromagnetic valve.  
For other notes, refer to text

With this new technology the function of the bag was replaced by modern valves. What was new with these valves was the electromagnetic drive which replaced the pneumatically or electrically driven mechanism. The electromagnet drive had been established several decades earlier before it was first used in ventilation technology. It was used in loudspeakers as the electromagnets vibrating at such speed created sound. The next diagram shows the functional operation of an electromagnetic valve for dosing gas.

But the new valves were not just fast. Using the new microcomputer technology they could be controlled very quickly and precisely. This latest technology offered new dimensions in dynamic dosing of inspiratory gases. The same applied to the function of the exhalation valve which was operated for the first time in the EV-A indirectly via an electromagnet and controlled by a microcomputer.

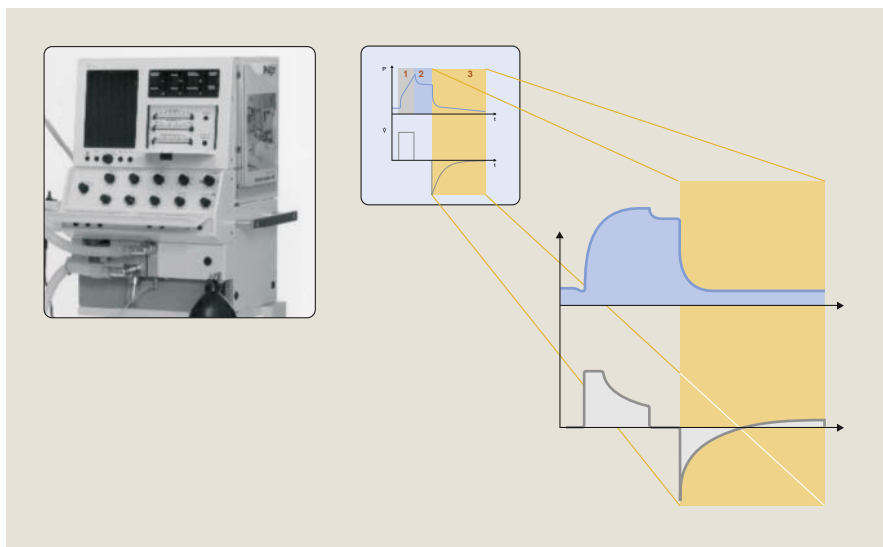

Ventilation curves from an EV-A. Compensation of leakage:  
Note the compensation flow in the last section of the expiration phase

The new technology only advanced machine ventilation a small step, despite its enormous potential. For the first time the EV-A could maintain operation despite a leakage in the PEEP. The ventilation curves clearly show leakage compensation in the flow curve of the exhalation phase.

With its dynamic inspiratory gas dosage the EV-A was now able to supply just enough gas as escaped via a leak, for example at the tube. However, technical innovation through microprocessors did not mean only progress for ventilation. It was also the reason for erroneous developments. From today's point of view we look on the increase in ventilation modes without any significant therapeutic benefit as erroneous developments. Inflation in the ventilation modes made ventilation more complex - but not necessarily better.

## Simple and Open for Spontaneous Breathing – Pressure Controlled BIPAP\*

Not until half a century later would a simplification of machine ventilation come about with the BIPAP ventilation mode (1,3,17). The new mode was characterized by an unusually broad spectrum of applications from pure machine ventilation to pure spontaneous breathing. Shortly after its publication it was available for many clinical applications from 1988 on with the first generation of the Evita series.

The most important advance with the new mode was the possibility of spontaneous breathing during artificial ventilation. This solved the last of the three problems of machine ventilation described above. Conventional machine ventilation did not allow spontaneous breathing during mandatory breaths. The patient could not breathe out during mandatory breaths since the exhalation valve was closed. The solution was the “Open System” principle which was introduced with the Evita ventilator.

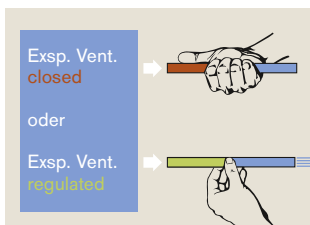

Function principle of the “open system.” For other notes see text

In conventional machine ventilation the ventilator keeps the exhalation valve firmly closed like a strong hand squeezing a tube. In the “Open System” the exhalation valve regulates gently like a sensitive hand adjusting the flow delicately. The principle of the “Open System” is the technical basis for implementing the new pressure-controlled BIPAP mode.

Any available opportunity for spontaneous breathing can be identified in the flow curve of the graphic on next page. For the first time exhalation is possible during the machine inspiration phase.

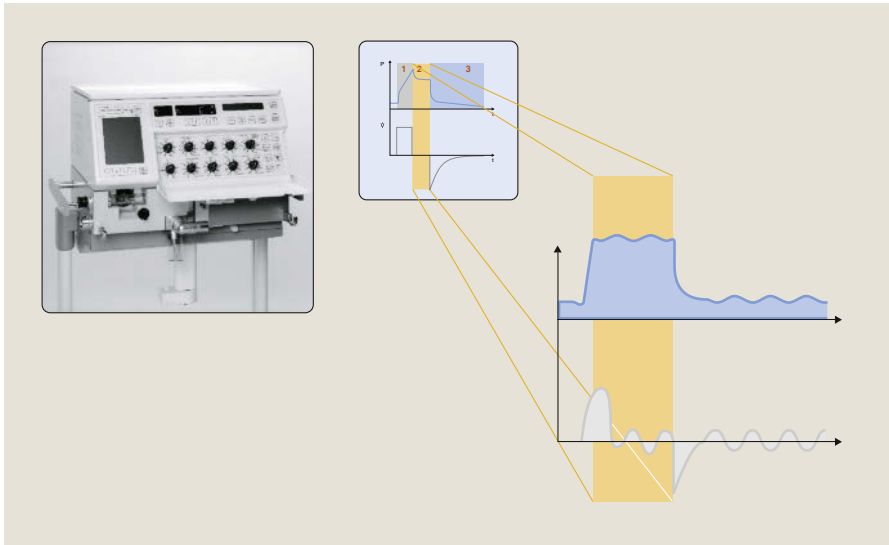

Ventilation curves on an Evita. Spontaneous ventilation throughout the complete ventilation cycle. Note the expiration flow during the mechanical lift

BIPAP advanced the development of ventilation in two important ways. Firstly, BIPAP reduced the number of necessary modes due to its broad application areas (3,17) and thus ventilation became simpler. Secondly the mode gave the patient more room to breathe with the possibility of spontaneous breathing during a mandatory breath. This improved the conditions for gas exchange (20) and reduced the negative impact of ventilation on the lungs and cardiovascular system.

## Optimum Pressure and Open for Spontaneous Breathing – Constant-Volume AutoFlow\*

The BIPAP mode brought pressure-controlled ventilation to an advanced level. It was several years later before the next significant improvement now in volume-constant ventilation came in 1995 with the introduction of Evita 4.

The problem of pressure peaks in the inhalation phase with constant-volume ventilation still was unresolved. Although the pressure peaks could be eliminated with the pressure limitation of the UV-1, they still had to be reset frequently during the ventilation process. A manually adjusted pressure limitation however is only ideal if the mechanical conditions in the lungs remain unchanged which is normally not the case with a ventilated lung.

The mechanical properties of the lungs change during ventilation; they can become more rigid or more elastic. In respiration physiology we call this phenomenon a change in compliance. In addition the flow resistance in the airways can increase or decrease.

For example, if compliance in the lungs increases and the lungs become more elastic during therapy, lower ventilation pressures are sufficient to administer the required volume. Hence increased compliance requires less pressure for the required volume to be administered. In fact, the clinicians should measure the compliance with every breath and then quickly set the lowest possible ventilation pressure.

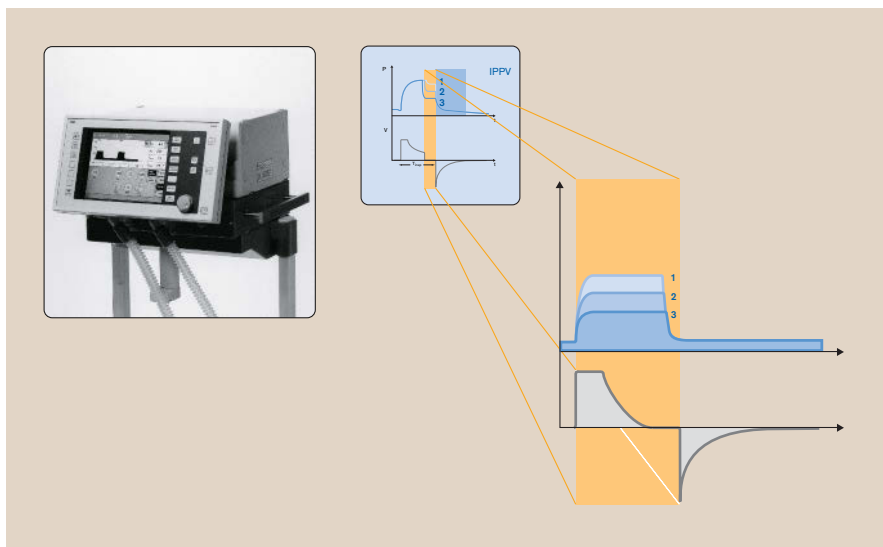

Ventilation curves on an Evita 4. The control of the ventilation pressure with AutoFlow: Three ventilation pressure curves taken at different times over a compliance increase

But this work is performed by the ventilator which automatically takes measurements of compliance and sets the minimum ventilation pressure. This principle is called AutoFlow. It is not an independent ventilation mode but is an auxiliary function available in all constant-volume mode. AutoFlow regulates the inspiratory gas flow according the actual lung mechanics in such a way that the breath volume is administered with the lowest possible pressure.

AutoFlow enables spontaneous breathing during a constant-volume mandatory breath. AutoFlow allows for “free breathability”, which has been proven over years of application in pressure-controlled BIPAP in a larger population of users.

## Pressure-supported Spontaneous Breathing

Parallel to time-cycled ventilation mode the pressure-supported modes developed. The basic difference between these modes compared to cycled modes is that no time intervals are set. The length of a mandatory breath is determined by the lung mechanics and the breathing activity of the patient. In addition every mandatory breath must be triggered by the patient.

The development of pressure-supported modes began twenty years later than time-cycled modes. The reason for the late start lies in the complicated control principle for these modes. The ventilator must first register when the patient wants to inhale to activate a pressure-supported mandatory breath. It then has to provide the necessary inspiratory gas at high speed and then end the supply of gas when the patient so requires. The requirements of such a ventilator are high because differences in the inspiratory gas supply and the patient's requirements will cause additional breathing effort and stress for the patient.

Pressure-supported modes are suitable for patients with sufficient breathing activity to trigger a mandatory breath but where the patient's breathing is insufficient to ventilate the lungs completely by itself. In order to support the insufficient spontaneous breathing, the ventilator can supply the patient breathing spontaneously with inspiratory gas with a slight positive pressure. The ventilator relieves the patient by removing some of the breathing effort.



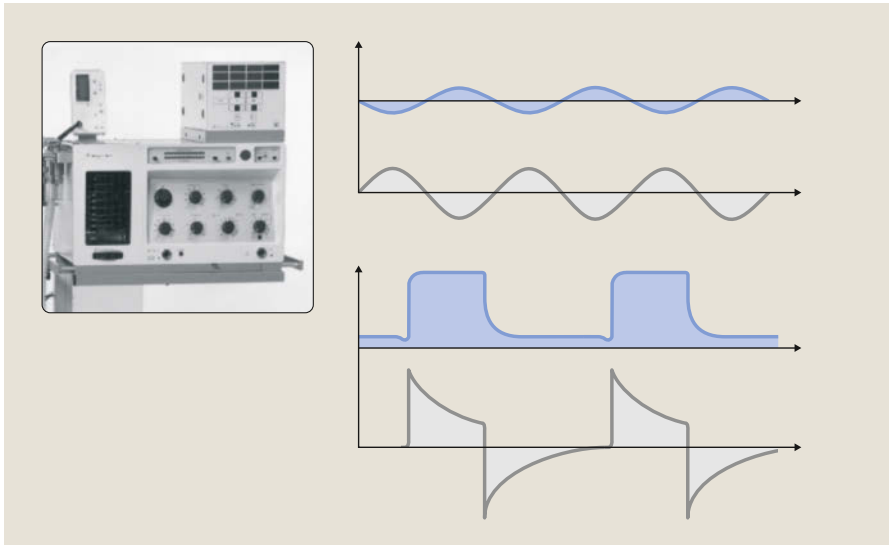

Ventilation curves from a UV-2. Top: Spontaneous ventilation without mechanical support

The start and finish of this pressure support is determined by the spontaneous breathing and lung mechanics of the patient. Only the value of the pressure support is determined by clinicians. The mode is called ASB\* or PSV\*\* and was first used at Dräger with a upgrade kit in the UV-1 and later in the UV-2.

\* Assisted Spontaneous Breathing, \*\* Pressure Supported Ventilation

## Adaptation of Support to Spontaneous Breathing

Pressure-supported machine ventilation offers relief without forcing a mechanically created ventilation pattern on the patient. Although machine ventilation adapts itself to the spontaneous breathing of patients to a certain extent in pressure-supported ventilation, there were some basic problems in the fine-tuning. Under certain conditions the pressure-support curve does not match spontaneous breathing. In addition, abrupt changes in pressure were unpleasant for the patient. Hence improved synchronization of pressure-supported ventilation to the patient's breathing was required.

Adaptation of pressure-support to spontaneous breathing was initially achieved by a manual correction to conventional pressure support. The manual adjustment of machine pressure support to spontaneous breathing and lung mechanics first became possible with the EV-A in 1982 using an additional adjustment parameter which is generally called a "pressure ramp". Since then the speed of the pressure increase can be adapted to changing lung mechanics using this parameter. Improved synchronization of pressure support with spontaneous breathing was achieved.

The time response for support is not only dependent on the breathing activity of the patient but is also determined by mechanical factors such as resistance and compliance. Therefore the length of pressure support can sometimes be shorter than the breathing effort of the patient. In this case the length of pressure support can be extended by a longer interval of pressure increase. However, this manual adjustment is often only successful in a limited number of cases.

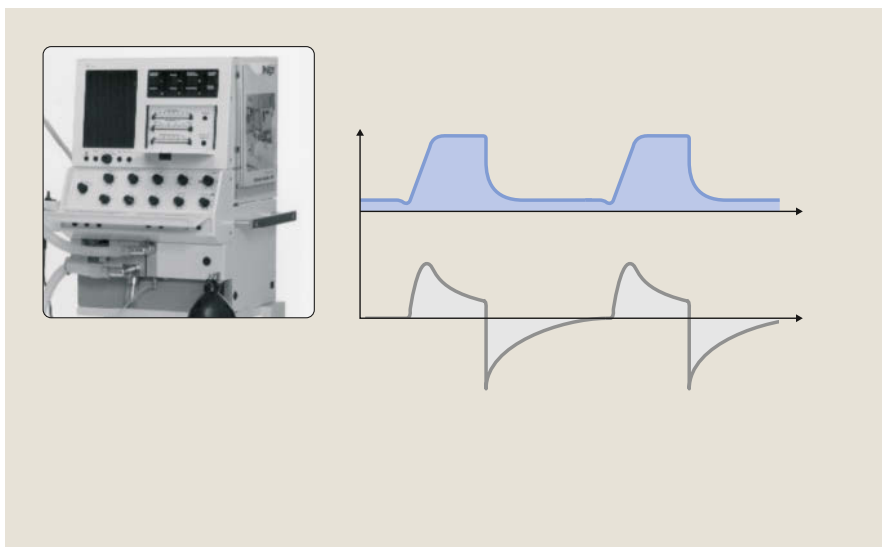

Ventilation curves from an EV-A. Pressure-supported spontaneous breathing with extended pressure by increased time

A further problem is found in weaning the patient from conventional pressure support. Here the objective is to leave the work to the patient to an increasing extent in order to wean them off the ventilator. Some patients “learn” that they only have to trigger a mandatory breath to receive machine ventilation support without making any significant effort themselves. Conventional pressure support, which was once introduced as an aid to weaning patients, is not suitable in such cases. These patients need a procedure where machine ventilation support is offered independent of the patient’s own efforts and hence “trains” patients to make the appropriate effort for their spontaneous breathing.

## Regulation of Pressure Support by the Patient

New ways had to be taken in the search for a method which provided pressure support depending on spontaneous breathing. Until now all methods required parameters to be set which determined the ventilation of the lungs. These parameters were volume or pressure. Here we will simply describe them as “ventilation parameters”. The result was that the command over time and volume in machine ventilation lay with the operator and not with the patient, which was particularly desired during the weaning process. This also applies to conventional pressure support.

However, if absolute security of ventilation by setting ventilation parameters is done away with and the emphasis is placed on supporting the patient in a targeted manner with the problems of their insufficient spontaneous breathing, this opens up completely new approaches. In this case the patient assumes responsibility for ventilating their lungs and the operator simply ensures that the ventilator provides sufficient support for spontaneous breathing of the patient by a suitable inspiratory gas supply.

The problems of insufficient spontaneous breathing can be complex. If limited to lung mechanics, there are two main problems. The respiratory apparatus can be too rigid and the patient receives too little inspiratory gas. In this case we talk of a restrictive dysfunction caused by too little compliance. On the other hand the airway resistance can be too great. In this case there is an obstructive dysfunction caused by too great resistance.

In order to target these dysfunctions, in the case of a restrictive dysfunction specific measures would be taken to increase the volume with the smallest possible effort by the patient, and in the case of an obstructive dysfunction the objective would be to increase the flow in the same way. That is exactly the underlying principle for a method which was launched in 1994 under the name of PAV\* (24) and since 1997 has been known as PPS\*\* and was available in a commercial available ventilator for the first time with the Evita 4 and later with the EvitaXL. In proportional pressure support neither a defined volume nor a defined ventilation pressure is intended. The goal is rather to adjust the percentage of respiratory work which man and machine share.

\* PAV =Proportional Assist Ventilation, \*\* PPS = Proportional Pressure Support

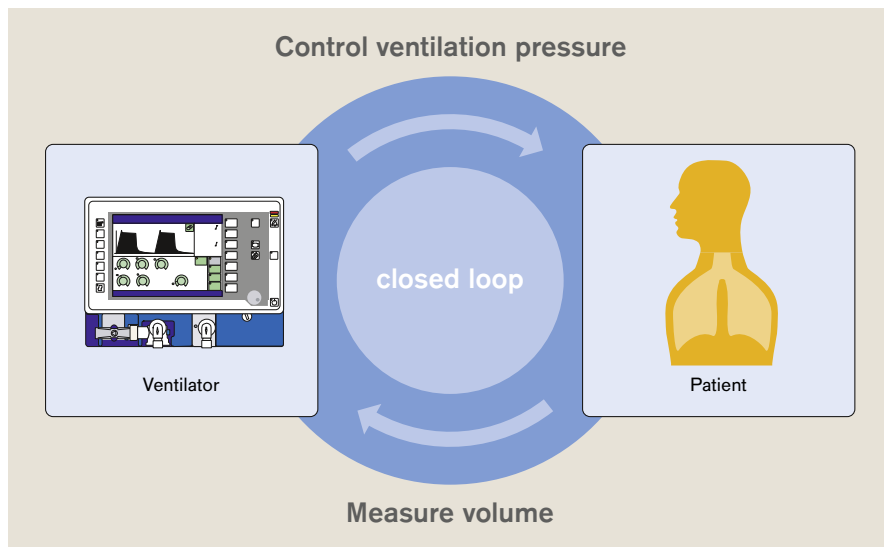

Regulation of pressure in proportional pressure support.  
The control loop is completed in a few milliseconds. For other notes, see text

In proportional pressure support the pressure is regulated according to measured volume and flow. The control cycle is exceptionally quick. Values are checked every eight milliseconds and the pressure is corrected correspondingly. This means that pressure is measured more than one hundred times per mandatory breath and adapted to the needs of the patient.

This enables spontaneous breathing problems to be treated in a targeted manner. With restrictive dysfunctions the pressure is increased in proportion to the volume and the adjustment parameter is called volume-assist. Obstructive dysfunctions are treated similarly using a flow-assist. Evita supports users when setting the parameters and provides information on which resistance and which compliance are compensated.

## The Issue of Connecting the Ventilator to the Patient

During mechanical ventilation, patient and ventilator are connected by means of ventilation tubes. The direct connection to the respiratory tracts of the patient, the tube, causes an additional breathing resistance due to its small diameter. The strain on the patient caused by additional tube-related breathing effort can be avoided by taking two steps. Either the additional effort is compensated by the ventilator or the cause of the additional effort is replaced with an alternative ventilation connection.

An alternative ventilation connection is the ventilation mask which does not require any significant additional effort in contrast to a tube. However, a ventilator has to be adapted specially for ventilating via a mask since considerable leakage can occur with masks. Adaptation is termed non-invasive ventilation NIV\*\*. It consists of much higher automatic leakage compensation and adjustment to ventilation monitoring with selective alarm muting.

Non-invasive ventilation is available as an option for almost all of Dräger's ventilators for intensive care ventilation for adults, transport ventilation and neonatal ventilation. The Carina has a special place in non-invasive ventilation. It was developed specifically for this purpose, i.e., it is a special NIV ventilator that can also ventilate intubation patient.

The second possibility for reducing the tube-related breathing effort for the patient is selective compensation of the breathing effort. To understand compensation for tube-related breathing effort, it is useful to take a closer look at the pressure conditions before and after the tube. If the patient breathes through the tube, a drop in pressure occurs in the tube, as shown in the graphic. This drop in pressure increases, the more vigorously the patient draws the breathing gas into the tube. The drop in pressure is therefore dependent on the breathing gas flow.

\* NIV = Non Invasive Ventilation

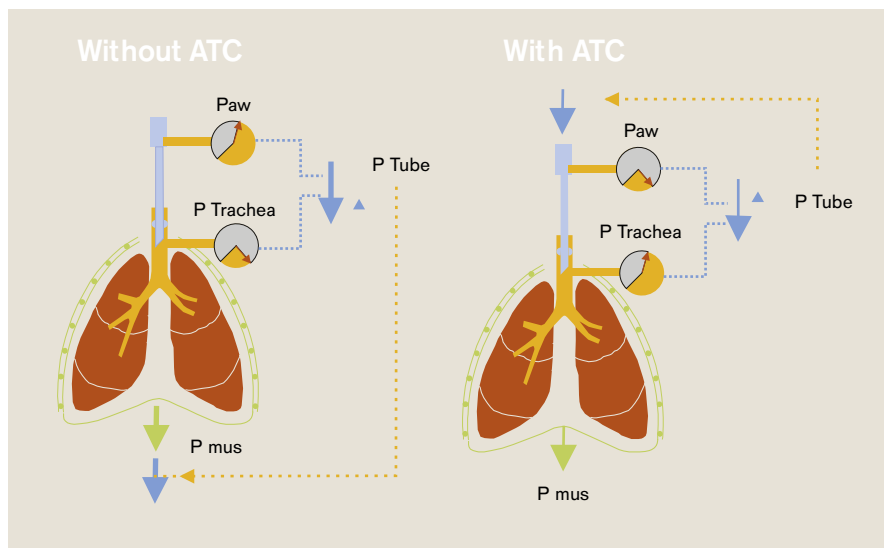

Compensation of the breathing effort due to the tube. ( $P_{aw}$  = airway pressure)

*Left:* Without tube compensation – the tube causes an additional fall in pressure and the patient must compensate this fall in pressure by forced breathing ( $P_{mus}$  = pressure from breathing muscles). *Right:* With tube compensation – the ventilation device compensates the fall in pressure by additional ventilation pressure

Of course, the ventilator could supply greater ventilation pressure to compensate for this drop in pressure and that is exactly the principle of ATC\*, automatic tube compensation. The ventilator exerts just enough pressure as the patient would have to exert to transport the inspiratory gas through the tube. The patient experiences this as a help. Although the patients are breathing through the tube, they do not sense the resistance and the corresponding additional effort which is assumed by the ventilator via the ATC – a phenomenon which is also called “electronic extubation”. Automatic tube compensation was presented for the first time in 1997 with the launch of the Evita 4 and since then has gradually become standard in intensive care ventilation.

## Specific Characteristics of Infant and Neonatal Ventilation

Ventilation of infants and new born babies has a special status for two reasons. Firstly, there are specific clinical problems when dealing with immature lungs and secondly, there are additional technical challenges in neonatal ventilation.

Specific clinical problems of immature lungs includes, for example, the lack of surfactant, a vital liquid film in the lung. A typical complication is aspiration of amniotic fluid which frequently leads to pneumonia. Respiratory dysfunctions are one of the main causes of neonatal deaths.

The technical challenges of neonatal ventilation lie in the type of ventilator connection. The ventilation tube is normally not fixed in the windpipe but a so-called uncuffed tube is used which is open to frequently unavoidably high leakage. In addition, ventilators for newborn babies work with a continuous gas flow. In principle this is an optimum solution for the small patients but creates additional difficulties when monitoring ventilation. Additional demands on ventilators are made when treating these clinical pictures described above where dramatic changes in the lung mechanics can occur. The monitoring equipment must identify these changes and ideally, the device should automatically adapt to the changes in the lung mechanics.

In view of such challenges it is not surprising that a ventilator which satisfied all the above criteria was not developed until the end of the 1980s. The Babylog 8000 was the first neonatal ventilator which had integrated volume monitoring and allowed the lung mechanics to be diagnosed. It offered flow measurement close to the patient, combining automatic leakage compensation with a very sensitive trigger for activating a machine breath by the weakest patient.





Babylog 8000

Four years after its introduction, the Babylog 8000 was able to be upgraded with high-frequency ventilation which was the alternative to conventional ventilation in cases of severe respiratory insufficiency. In 1997 two new modes were introduced which were already established in adult ventilation and had been optimized for the special requirements of neonatal care by sensitive adjustment; pressure-support ventilation PSV\* and volume guarantee VG. Pressure support gives newborn babies freedom to breathe. The patient determines both the start of inhalation and exhalation, thus making it ideal for weaning neonatal patients (21). The volume guarantee reacts automatically to changes in the lung mechanics and hence reduces the risk of over-dilating the lungs caused by a rapid change in the lung, for example when administering surfactant.

With the launch of the Babylog VN500, the range of ventilation systems was expanded and especially the high-frequency ventilation was improved significantly. Thanks to the large graphic screen with touch screen technology, the ventilation monitoring and operation of the Babylog VN500 reach the same high standard as in the ventilation of adults.

\* PSV = Pressure Support Ventilation

## SmartCare/PS

The ventilation modes described here may be very different but they all have one thing in common: They are all adjusted manually according to the individual decisions of clinicians. Such decisions do not happen often and frequently do not follow a predetermined plan. Therefore guidelines, for example, in the weaning process, were drawn up to give exact instructions on actions such as setting parameters.

In the middle of the 1990s it was possible to implement guidelines on weaning with the aid of a computer. The computer was in a position to use the ventilation monitoring values to analyze the status of a patient and design a treatment plan based on guidelines which were stored in software. Indeed, it went one step further and the computer was authorized to implement steps in the treatment plan automatically and to control a ventilator.

The first clinical tests of this new automatic weaning were performed with pressure-supported ventilation and were carried out with a modified computer-controlled Evita 4. The results of the study were revolutionary and meant the weaning process only took half as much time (19). The next step was the integration of a computer for automatic weaning into a ventilator specially designed for this purpose, the EvitaXL. The market launch of computer based weaning was done in 2005 under the product name SmartCare®/PS. Computer-assisted automatic weaning had for the first time become an integral part of a commercially available ventilator.

SmartCare/PS behaves in a similar way like clinicians during the weaning process. First a diagnosis of spontaneous breathing is made on the basis of three parameters – frequency, tidal volume and end-tidal CO<sub>2</sub>. In cases of insufficient spontaneous breathing pressure support is modified automatically to stabilize the patient and spontaneous breathing. Once this has been achieved, pressure support is reduced successively to a level where the patient can be expected to continue to breathe without support. At this point SmartCare/PS carries out a maneuver, the spontaneous breathing test. If this is successful, clinicians are informed of the conclusion of the weaning process.

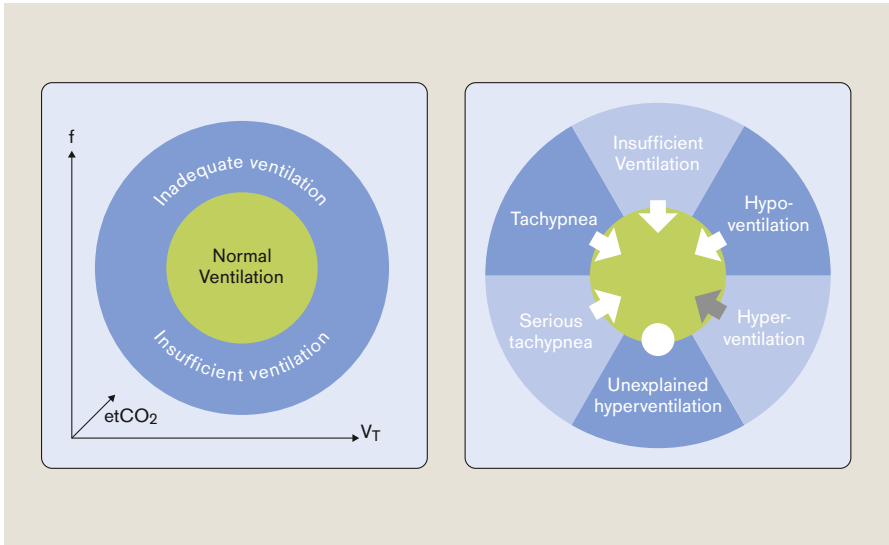

**Diagnosis of spontaneous breathing and stabilization measures in the SmartCare/PS.**

*Left:* Breath frequency, tidal volume and end-tidal CO<sub>2</sub> are assessed. If one of these values is unacceptable “inadequate spontaneous breathing” is recognized. *Right:* Differentiation of the fault, possible stabilization by changing the pressure support (light arrow = pressure increase, dark arrow = pressure decrease, loop = no change). After successful stabilization weaning is started and implemented automatically by reducing the pressure support

The role of clinicians with a SmartCare/PS application is similar to the role of a pilot flying on autopilot. Just as a pilot can at any time get an overview of the course, speed and altitude while they are being controlled automatically, clinicians can view progress, diagnoses and measures which are being performed automatically. And like a pilot, the clinicians can intervene more or less manually. The staff feel they are of more value. They are freed from routine activities and are well informed about the progress of treatment. Both doctors and the healthcare staff become designers rather than performers of the weaning process.

## Trends in the Development of the Ventilation Modes – Conclusion

In the development of ventilation modes, two main trends can be identified. Firstly, ventilation has become more patient-oriented and secondly, it has become more user-oriented.



Evita 2 and developing the procedure. Ventilation pressure curve from bottom to top: Volume constant, pressure limited, conventional pressure control and BIPAP

The development of machine ventilation began with machine “air pumps” to supply inspiratory gas to patients. The next stage in development saw the introduction of auxiliary devices to adapt machine ventilation to patients. Clinicians used these as additional adjustable parameters in ventilation modes.

In time-cycled ventilation pressure limitation was used as an auxiliary parameter to minimize the mechanical strain on the lungs. Pressure support was introduced in spontaneous breathing to offer the patients relief from their breathing efforts. In both cases, pressure limitation and pressure support, the technology used was fairly simple while its application was labor-intensive. If the lung mechanics changed, the clinicians normally had to modify ventilation.

In the next development stage the function of manually adjustable auxiliary parameters were gradually taken over by “intelligent” functions of the ventilator. With AutoFlow, free breathing and proportional pressure support, the ventilator adapted automatically to changes in lung conditions and physiological breathing. In patient-oriented ventilation the ventilator now obeyed the patient.

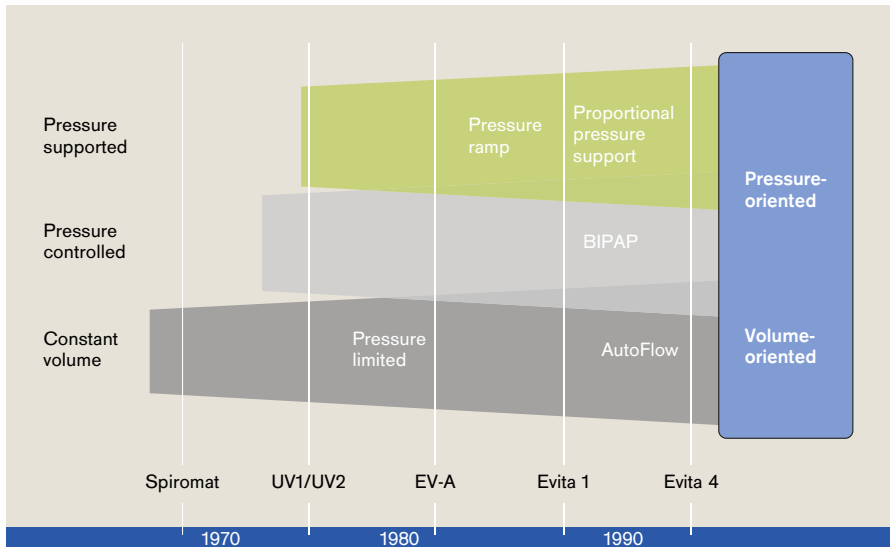

**Number of ventilation modes. 1970: Few modes due to technical limitations. 1980: Many modes due to new technical options. Since 1990: Fewer necessary modes due to more patient-oriented and application-oriented modes**

The second trend is a simplification of ventilation which has made ventilation more user-oriented. Ever fewer modes are needed. The numerous modes of older devices were determined by the limited technological possibilities. It was simply not possible to do things better and for each technical and medical problem a special mode was required. The introduction of BIPAP in the weaning process was a decisive step in simplifying ventilation and with BIPAP there was furtheron only one mode needed for weaning. In pressure- or volume-oriented ventilation there is now a simple choice between two alternatives, BIPAP and AutoFlow.

## Tendencies in the Development of the Ventilation modes – The Future

A look into the future of ventilation modes became possible with the introduction of knowledge-based systems such as SmartCare®. In the future it will be less a matter of optimizing modes and more a question of implementing the modes in optimum fashion. SmartCare/PS uses conventional pressure support, that means, the mode is conservative. But the innovation of SmartCare/PS is the standardized use of a mode according to established rules. This offers considerable benefits such as the economic advantages described above and the possible quality assurance through standardization.



Evita V500. The depiction of realtime curves, trends and data is set optimally for a SmartCare/PS application

The question we ask ourselves after one hundred years of machine ventilation is the following: Will conventional ventilators as we know them today as independent devices be in a position to master the challenges, for example, posed by knowledge-based systems? The answer is “yes – with a great deal of work”. The new challenges of knowledge-based systems can be met by an independent ventilator such as the EvitaXL once the computer is fully integrated into the ventilator for automatic control.

New device generations, such as the Evita V300 and Evita V500, on the other hand, are prepared to automate ventilation with knowledge-based systems using their basic configuration – without additional hardware.



Infinity® Acute Care System™. Medical Cockpit and Ventilation Module V500

If, however, future demands in ventilation require external device operation, this could add another sector to mechanical ventilation. Apart from the independent ventilators, systems could be established, where a central control unit accesses a ventilation module. Dräger took the first step toward this new sector in 2006, when they introduced the Infinity® Acute Care System™.

## From Measuring Instrument to Ventilation Monitor

We have described the development of ventilation modes and will now take a look at how ventilation monitoring has developed parallel. Ventilation monitoring represents the whole system for surveiling ventilation. Both the equipment functionality and the condition of the patient are monitored.

Monitoring consists of the three functions measuring, displaying and warning. Ventilators require sensors, a display and an alarm system. Nowadays we would add a fourth component, data management.

Even the original Pulmotor had a modest sensor. A simple instrument for measuring the ventilation pressure enabled superficial observation of performance. From 1955 onwards the Spiromat was fitted with an additional measuring device for the volume administered. Further measuring parameters such as the inspiratory concentration or the inspiratory gas were introduced in the subsequent generations, initially via auxiliary monitors. In modern ventilators monitoring of the inspiratory concentration is normally integrated in the ventilator itself and monitoring the inspiratory gas is available as an option.



Airway pressure monitor on the UV-1 with depiction of limit values

On the basis of the values measured, further data can be extracted through calculations. An example for a calculated value is the mean airway pressure which is determined as an average value. Admissible limiting values normally apply to both measured and calculated data. If these limits are exceeded an alarm system is triggered which informs the user with both acoustic and visual signals.

The limit values for patient monitoring are set by the clinician, as the following example of monitoring the airway pressure in a UV-1 shows. The limiting values for monitoring by devices, on the other hand, are generally set automatically in modern ventilators.



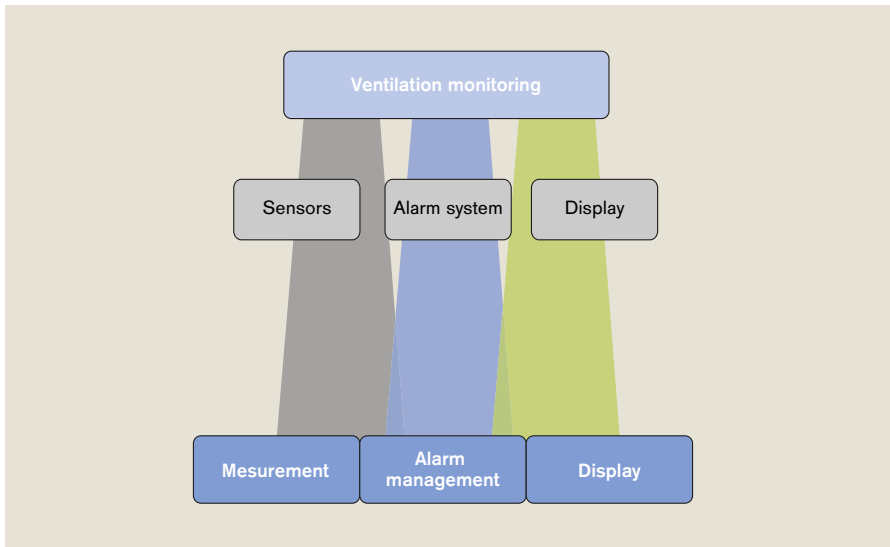

Ventilation monitoring. *Center: components, bottom: Sub-functions*

The alarm system for ventilators has developed in a similar fashion to the development of sensor technology with its increasing integration in ventilators. The alarms from the different ventilator monitors replaced by an alarm management system in the ventilator. Alarm management in modern ventilators does not simply manage the individual alarms but provides detailed information via text messages, such as the reason for the alarm and it gives a diagnosis and shows ways for a possible solution of the underlying problem.

## From a "Snapshot" to a Trend Analysis



Digital display of various measurement values on an Evita 2

Parallel to sensor and alarm technology, the display technology of ventilators has also developed.

Simple reading instruments have been enhanced or replaced by digital displays. The information offered from ventilation monitoring has become more complex – at times the numerous displays

can overwhelm the user. Easier assimilation of information was achieved by concentrating readings and text messages on a central screen.

However, the central screen does not simply manage the various displays and messages, it enables a completely new way to display values. Graphic screen displays do not simply show current values, they can also show the progression over time.

Such graphic displays were already common in cardiovascular diagnostics, e.g. as ECG waveforms. Although the diagnostic value of graphic monitoring is very high, it was not introduced into ventilation until the integrated screen on the EV-A. Since then it has been a standard part of every Dräger intensive care ventilator.

Graphic monitoring enables time curves for a ventilation breath to be displayed. The ventilation curves described, which have been in the previous paragraph to explain the ventilation modes can be displayed directly on the ventilator. The middle diagram on the next page shows a ventilation pressure curve.

The ventilation curves displayed on screen can be used to control ventilator settings and their effect on the patient. The current status displayed in ventilation curves in modern ventilation monitoring is supplemented with displays of longer-term developments.

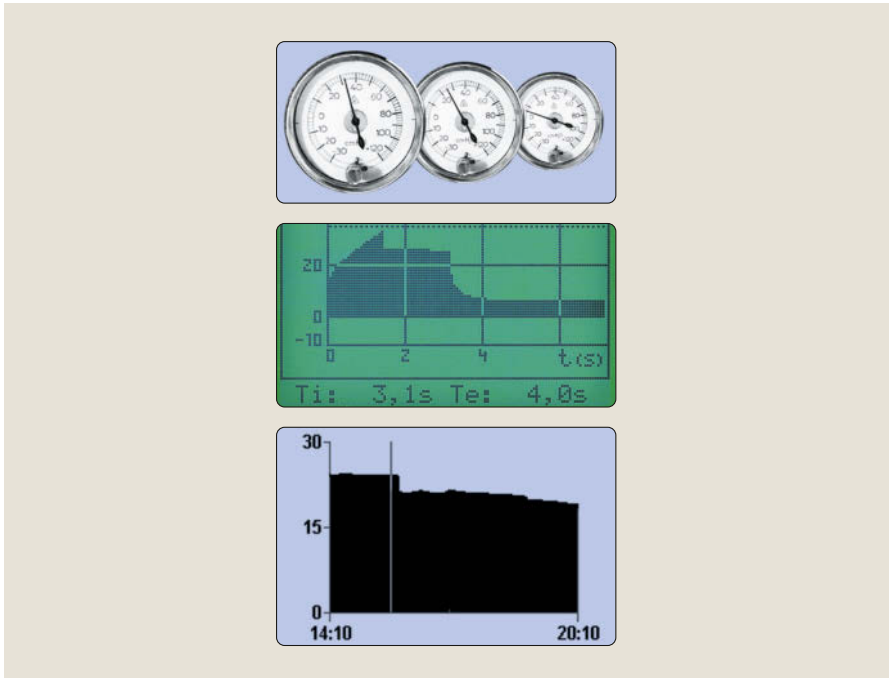

Measured value depiction of the airway pressure in ventilation monitoring. *Top*: Spiromat indicator. *Center*: Ventilation curves on an Evita 2. *Bottom*: Trend depiction on an Evita 4

Experienced specialists can also recognize trends from such displays, which is why displays are also called trend curves. These are available within the integrated ventilation monitoring in Evita. The bottom diagram shows a trend curve for the mean airway pressure.

Next we will describe the benefits of graphic monitoring for training, diagnosis and implementing equipment using ventilation curves as examples.

## The Value of Graphic Monitoring

We have described the principle of airway pressure and flow curves in the section “Ventilation Modes.” Ventilation curves act as aids to illustrate the progress of the modes. The value of ventilation curves in training was recognized long before screen displays were integrated. The instructions for the Spiromat series already contained such curves.

Since the introduction of integrated graphic ventilation monitoring in the EV-A series, ventilation curves are used to an increasing extent as aids to setting the ventilator. For example, it is easy to tell from pressure and flow curves if the ventilation phase settings are correct.

Ventilation curves allow the machine settings to be checked quickly and incorrect settings identified easily. Settings with a high clinical importance such as the I:E ratio and the time ratio of inhalation to exhalation time, flow time and plateau pressure time can be viewed at a glance and do not have to be compiled out of combinations of figures.



Evita 2. Top: Real time curves for flow, pressure and CO<sub>2</sub>

However, verification possibilities offered by ventilation curves are not limited to improve machine settings and to prevent errors. They also provide an insight into the physiological effects of ventilation. They therefore become a diagnostic tool. Drawing conclusions on airway resistance and compliance can be drawn from pressure and flow curves. However, the two ventilation curves only give an approximate representation of the actual mechanical conditions of the lungs. Conclusions on gas exchange or even the blood supply to the lungs however are not possible from these curves.

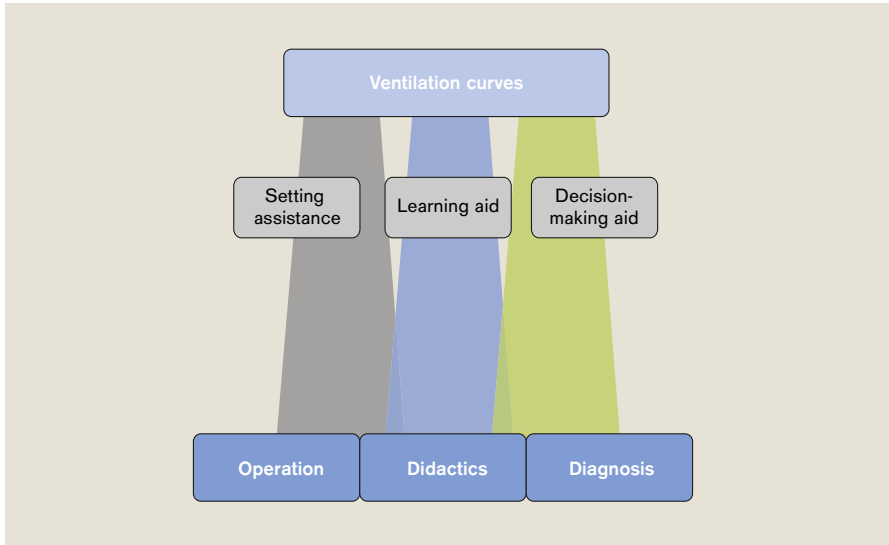

Ventilation curves in ventilation monitoring. *Center:* Sub-functions. *Bottom:* User benefit

The demand for a ventilation curve with a higher diagnostic value was met with a third ventilation curve. The graphic representation of the inspiratory gas in a ventilator is called capnography. It was first available in the EV-A series and since then has been expanded several times with additional diagnostic functions such as measuring CO<sub>2</sub> production and the dead space volume.

Capnography allows changes in gas exchange to be recognized rapidly. Insufficient lung ventilation or deterioration in the blood supply to the lungs are reflected in the curve. Capnography even allows conclusions on the metabolic condition of the patient to be drawn and hence exceeds the limits of pure ventilation monitoring.

## Ventilation Monitoring in a New Era

Despite the importance of capnography with its detailed display of physiological processes, it has one small disadvantage. The causes which lead to modified capnograms are generally not conclusive. Capnography provides valuable indications – but scarcely any proof. The ventilator's monitoring system was not sufficient to offer a totally reliable and differentiated diagnosis of the patient's condition and further data and integration in a central unit were needed.



Data presentation with the Infinity® Explorer

Towards the end of the last century the development towards central monitoring began, with part of the ventilation monitoring also being displayed on the patient monitor. A new screen technology made this possible and hence the standard size of the screen in patient monitoring grew within the space of a few years. Real time curves for ventilation, invasive blood pressure and ECG were available at a glance, the mass of data on the screen was almost too much. In addition, data, which had been

available for some time in patient monitoring such as oxygen saturation, was displayed on the ventilator screen.

An elegant solution would have been to eliminate double displays in ventilation and patient monitoring. But the problem was that ventilation monitoring and patient monitoring data are displayed differently and people wanted a complete set of data for each field. Therefore the costly capnography technology with expensive sensor technology was made available for both displays. Capnography had become redundant – and that was quite simply a waste of resources.

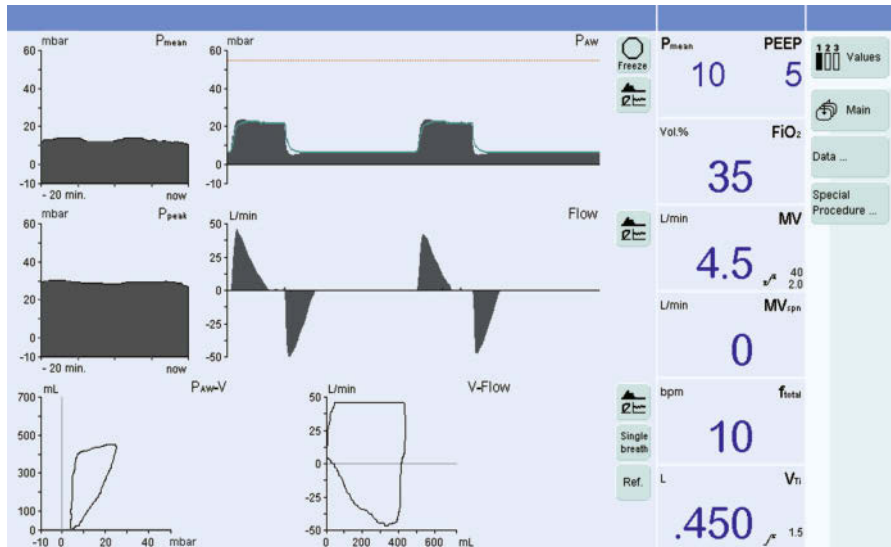

Data presentation on an EvitaXL screen. Real-time curves, loops and trends and numerical data can be configured

The question now arose whether an optimization of the independent ventilators and patient monitors would provide a solution for the problem of overabundant data and redundancy – and the answer again is “Yes – with a lot of work”. The adaptation of the data display of the EvitaXL and the Infinity patient monitor has at least partially solved the problem.

## Ventilation Diagnostics with New Images

The purpose of a monitoring device is to generate easily accessible information from various types of data. Now the question is, whether displaying numbers, text messages and curves on the screen of the ventilator serves this purpose. The opportunities resulting from modern monitoring can cause an uncontrollable flood of information that can overwhelm the user. The computer industry recognized this fact more than 10 years ago. For example, the Windows® computer operating system has replaced most text messages with symbols.



Graphic representation of the lung function in Smart Pulmonary View: changes of resistance and compliance identifiable in a model of the respiratory system

A similar principle can be found for ventilation monitoring with Smart Pulmonary View. Lung function parameters such as resistance and compliance are not only displayed by numerical values, but also by graphics.

In a model of the respiratory system, the thickness of the thoracic wall symbolises the compliance and the constriction of the trachea symbolises the resistance. Other graphic representations allow a quick insight

into spontaneous breathing: The ratio of spontaneous breathing and mechanical ventilation is symbolised by varicoloured areas and a moving diaphragm indicates that the patient triggered a mechanical breath.

The ventilation monitoring described here is multifaceted and complex, but only shows the overall lung function. It cannot detect regional differences within the lung and therefore does not provide detailed information of major clinical significance. There is increasing evidence that excessive ventilation pressures cause overstretching and too little pressures cause certain lung regions to collapse. Electrical impedance tomography now allows an insight into the function of different areas of the lung.





Electrical impedance tomography with PulmoVista 500. Graphic representation of regional pulmonary ventilation.

This imaging method has been adopted by Dräger in a commercially available device for the first time in the world under the name PulmoVista 500 in 2011.

Via an electrode belt, the PulmoVista 500 transmits harmless currents into the tissue in fast sequence and determines electrical resistances in a thoracic cross-section level. Using complex computer technology, images and real-time curves of the regional distribution of ventilation are generated from these signals. With these images, the user can identify which areas of the lung are well ventilated and is also able to see where ventilation is impeded. With images like these, the user can adapt ventilation in a more focused way. In addition, the images and other trends display, whether the adjustments of ventilation have the desired effect.

## Performance and Operation

After the ventilation modes and monitoring, we now come to to the operating concept for ventilation and monitoring from a historical point of view. In contrast to the ventilation modes and ventilation monitoring, the operating concept for ventilators was developed very late. The operating elements were initially placed randomly and quite often they were unsuited to the user.

The first ventilators were easy to operate because of their limited performance. However, with enhanced performance the number of operating elements grew. The curve shows the number of operating elements and the performance for various devices.

The diagram contains the following simplifications: The scope of performance of a ventilator consists of the sum of ventilation modes and other functions. The number of operating elements only includes dials. According to this schema the Spiromat had only one ventilation mode and with sigh ventilation just one other function. The machine could be relatively easily operated with six dials. The UV-2 had three ventilation modes and three additional functions: in addition to sigh ventilation, adjustable O<sub>2</sub> concentration and pressure limitation were added. Operating the machine was now quite complicated with eleven dials.

In the following machine generations ways were found to simplify operating the machines. For example, dials on the EV-A had two functions to stop the number of dials growing even further. However, these simplifications frequently proved to be simply cosmetic. Operating the machine appeared simple but its operation became more complicated.

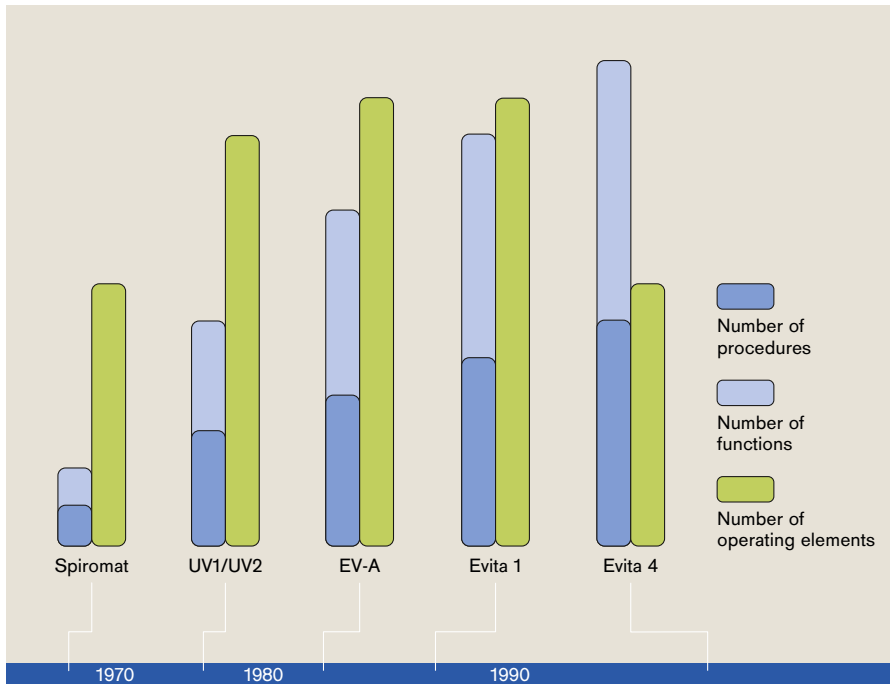

Development of the scope and the operating elements on the ventilation devices.  
For other notes refer to text

The operational development in ventilation took a different path than the development of modes and monitoring. Although there were some successes, there were also setbacks. Finally the equipment could only be operated safely after considerable training. This negative trend was not revised until the advent of Evita 4 and EvitaXL. A new technology reduced the number of operating elements which were also visible yet nevertheless increased the scope of performance.

## High Performance, Easy to Use – A Contradiction?

Of course there were remarkable advances in the development of the operating concept and not just the setbacks described above, such as the introduction of the central screen as a control instrument for settings.

Another advance was the introduction of a user guide with protection devices for potentially dangerous settings. As early as 1982 the EV-A series automatically recognized excessive ventilation pressure or an unusual ventilation time ratio. LEDs on the corresponding operating elements and screen alerts not only warned personnel about dangers but also suggested countermeasures.

This meant that the operating process was partially guided and users achieved their goal, so to speak, in dialogue with the machine. For example, the device would warn the user of potentially dangerous settings for the ventilation time ratio. The support which a device offers for setting parameters is called the user interface.

A device with a good user interface is basically self-explanatory. The operating concept for such devices, which is comprehensible in itself once a few basic elements have been learned, is called intuitive. An intuitive user interface was first introduced in 1995 with the Evita 4 using the new technology and enhanced in the EvitaXL in 2002. The control elements are accessible via a screen except for a few frequently used functions. This touch screen technology offered two advantages.

The first advantage is the directed operation since only control elements which can actually be operated at the current moment are displayed, thereby reducing the number. An example of this is setting the ventilation parameters in two different ventilation modes. While one mode requires nine parameters, the other only requires four. If no settings are being introduced, all control elements are faded out and the screen becomes a pure ventilation monitor.

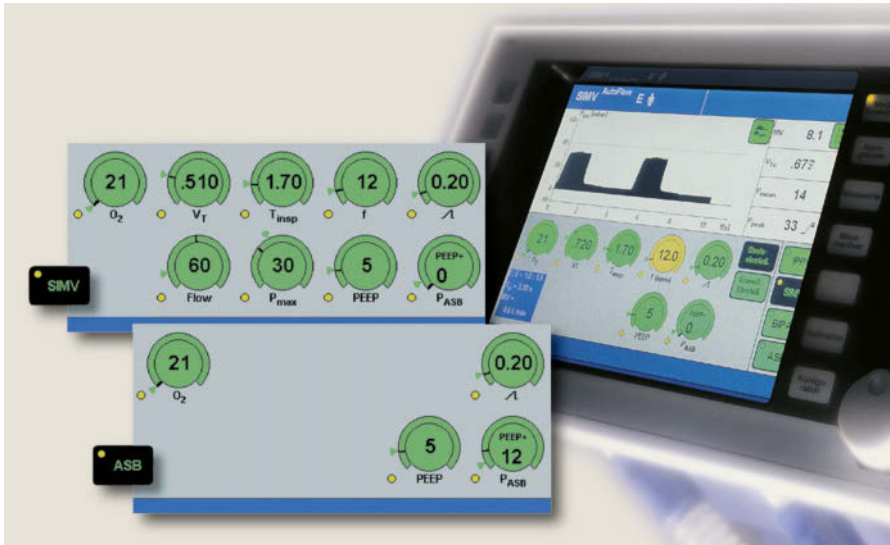

Screen operating elements on the Evita 4. For further explanations see text

The second advantage is derived from experience at other workstations. From investigations with commercial pilots, it is known that perceptible ability diminishes when under stress which is why the cockpits of modern airplanes have fewer instruments and control elements than previously. If these findings are applied to a workplace with a ventilator, then the new operating concept offers advantages from the safety aspect as well.

## Standardized Operation – A Vision?

Apart from the need to simplify operating a ventilator there is the requirement to simplify operating equipment within acute medicine. A simplification of operating concepts began at Dräger at the beginning of the 1990s with the introduction of a central dial in connection with a menu-guided interface.

This standard operating concept was gradually implemented across all areas of acute care. In anesthesiology, it was introduced with the anesthetic device Cicero and in intensive care it came in the year 1995 with the Evita 4. Its first appearance in the heat therapy area was with the incubator Caleo and finally it came to emergency medicine in 2003 with the Oxylog® 3000. Over time the operating concepts resembled each other increasingly and with the introduction in 2003 of the anesthetic device Zeus and the EvitaXL Dräger could offer a largely harmonized operating concept with a number of homologous operating elements in the OP area and in intensive care.

In spite of extensive harmonizing of operating concepts each device had a stand-alone operation causing two problems. Firstly, the problem of redundancy described in diagnostics applies also to operating units in the acute care workplaces. If in intensive care there are three modalities ventilation, infusion therapy and monitoring, then three devices are not necessarily needed to operate them – two would probably be simpler and more effective. Progress would be operating all modalities with only one or two universal operating units with the same architecture and the same hardware.

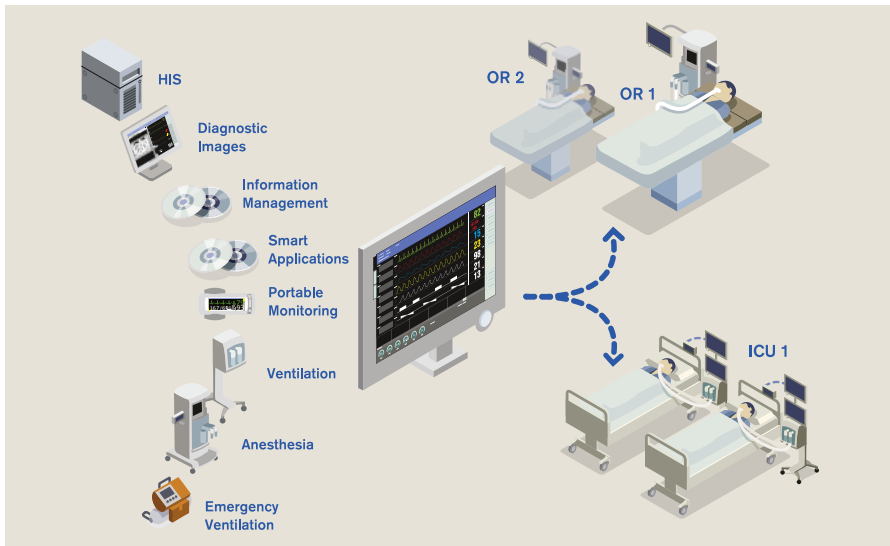

Standardised operation via a Medical Cockpit in all areas of acute care

The next step in acute care could therefore establish systems, in which the limitations of classical devices are more and more eliminated and operation is standardised even more. Medical Cockpits, such as the C300, C500 and the C700, which are currently being used as an all-purpose operating unit of a ventilator or a patient monitor, would then serve a new function. They would be the central operating unit of an acute care workstation, with which ventilation as well as patient monitoring could be regulated.

## From Ventilator to Ventilator Module

In the first hundred years of its history, machine ventilation has developed from a short-term emergency measure to a complex field within acute care thanks to technological and medical advances. The therapy, diagnostics and operating concepts of a modern ventilator are high performance, optimized for specific fields of application and innovative. Also in the the foreseeable future there will be many more new things with a clinical benefit within conventional machine ventilation.

A conventional ventilator naturally addresses respiratory problems first of all, but these are only a part of intensive care medicine. The first approach towards a holistic solution for intensive care units began in the mid-1980s with the development of an integrated system consisting of infusion and injection pumps, ventilation, monitoring modules and a central computer. The system was presented with the product name Carena in 1988 and created great interest in the clinical press (18). At the same time the integrated workstation Cicero was introduced in the field of anaesthesia.

The goal in developing Carena was to integrate the individual devices of an intensive care unit into a compact unit, organize displays according to medical needs, use a central screen to operate it and reduce displays to the absolute minimum.

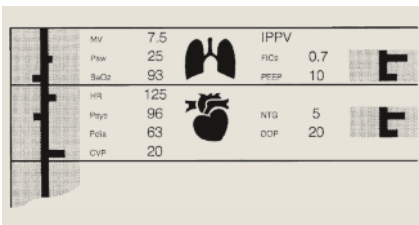

Carena. Data presentation

Carena already had networked components in a so-called Local Area Network (LAN) and data processing in a central computer, the so-called Data Manager. Reading values were compiled in logical groups and presented a deviation from the normal range which could be identified at a glance. In addition, Carena had central alarm management.





Carena. Integrated workplace concept in acute care medicine

In contrast to the anesthesia workstation concept Cicero, Carena was not a commercial success. One reason might be that various manufacturers were involved in developing specific components such as ventilation and monitoring. In the case of Cicero the anesthesia dosing, ventilation and monitoring were developments from within Dräger. This meant Dräger not only had the competency for the whole system but also for the sub-areas too and this appears to be a vital prerequisite for the success of such systems.

## From Module to Acute Care System

Both Carena and Cicero were closed workstations. However, the individual workstations were not isolated, rather they were part of a whole, namely acute care. Within the sub-areas of acute care the same or similar processes such as monitoring and ventilation are performed and often the same people perform them.

Acute care accompanies a process chain which can be easily demonstrated by following the path of a patient throughout their treatment. In a simplified example this begins with emergency care and the patient being admitted into hospital. A general diagnosis could be followed by surgery, with the process chain passing through the operating theater and the recovery room. This is followed by treatment in the intensive care ward or high-dependency unit before the patient is discharged after further treatment in a low-care unit.

If this process chain passes through the different sections with rigid divisions then the problems we have described that Carena and Cicero were meant to resolve will remain isolated in the workstations and not cross the boundaries. The problems are lack of standardization and gaps or unmanageable information. In addition there may be bottlenecks and waiting times when passing through the various stations. The different stations may have organized their workstations differently and if they are located far apart this adds the specific problems of patient transport.

This brings up the question which we already asked about the future of conventional ventilators: Can conventional apparatus and workstation concepts be optimized within the whole acute care field with standardized operability and standardized presentation of information so that they can be arranged ergonomically and minimize the dangers of patient transport?

And the answer is, again, the same:

“Yes - with a lot of work”.



Acute medicine departments: Operating theater



Acute medicine departments: Critical care ward

The effort required to harmonize them does not only apply to developing new equipment, it can be seen in daily operations. And effort translates into costs: investment costs and personnel interruptions.

## Acute Care Seen as a Whole

The first system which is not designed for individual modalities or individual workstations within acute care but which goes one step further to encompass the whole of acute care is the Infinity® Acute Care System™ (ACS), presented in 2006. The main features pursued in this new system are integration, standardisation, mobility and targeted information. In the future, these features could develop as follows:

Integration is provided with the Medical Cockpit across all acute care workstations. This central operating unit combines display and control functions for patient monitors, therapy units and the hospital information system. In the future, vital parameters and therapy progress can be tracked and findings can be analysed. Standardisation in acute care will in the future be achieved throughout different levels: The Medical Cockpit will standardise the operation of individual modalities and data will have uniform appearance. Throughout the entire system, standardised components and standardised accessories will be used.

Mobility will be guaranteed by continuous data collection with permanent data transfer to the central monitoring unit. Mobile ventilation units such as the Evita V500 and Evita V300 with the gas supply unit GS 500 and the power supply module PS 500 together with the transport supply unit TSU will ensure continued care for patients and at the same time minimise transport risk. Parameter settings will be stored on microchips in ventilation tubes using the RFID technique and transferred automatically when the equipment is switched. Data will be presented in appropriate forms and images, called smart views. These help to identify the condition of the patient fast and intuitively – data become purposeful information.

Apart from these new features described above, a system in acute care can be differentiated from all previous approaches. It is not supposed to be a rigid system; but should be adapted to specific needs using modular components. And it should be able to grow with these new demands – it should be scalable.

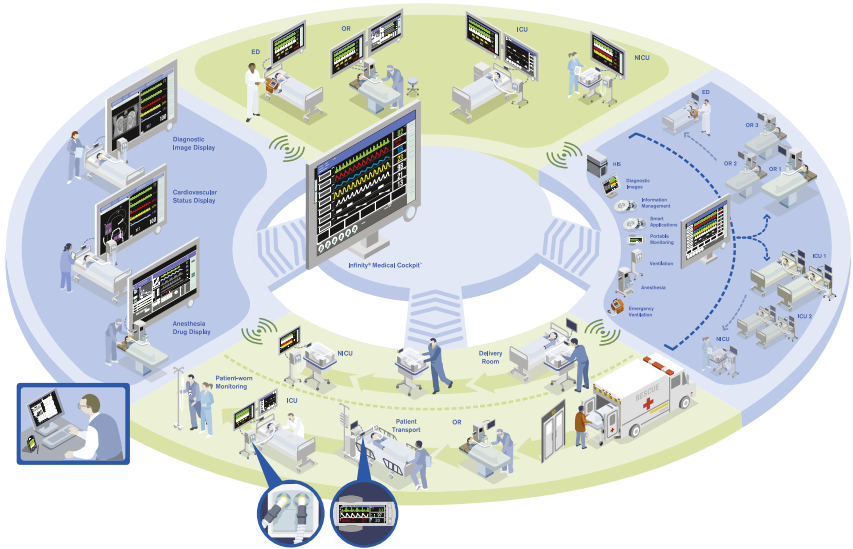

Continuous patient care across departmental boundaries. Standardized supply process without pauses

With this vision of new acute medicine 100 years after the first Pulmotor, the question of the second century of ventilation arises. The start of a new era is possible. The concept of conventional ventilation with a traditional ventilator could receive an alternative, namely integration of ventilation into a system which can fundamentally change the whole field of acute care.

The second century of mechanical ventilation will certainly bring further advances in therapy and monitoring techniques and build on the developments of the first 100 years. In one aspect however, history is repeating itself with a new “zero hour” just like the original Pulmotor. The story of new style acute care, where standardization, harmonization and integration of monitoring and therapy have the highest priority, has only just begun.

## Bibliography

- 1 Bahns E. (1995) BIPAP – Two Steps forward in Ventilation. Dräger, Lübeck.
- 2 Baum M., Benzer H. (1993) Einsatz von Atemhilfen.  
In: Benzer H., Burchardi H., Larsen R., Suter P.M. (Hrsg.),  
Lehrbuch der Anaesthesiologie und Intensivmedizin. 405 – 437.
- 3 Baum M., Benzer H., Putensen Ch., Koller W., Putz G.(1989)  
Biphasic Positive Airway Pressure (BIPAP) – eine neue Form der  
augmentierenden Beatmung. Anaesthesist 38: 452 – 458.
- 4 Burchardi H. (1993), Pathophysiologie der respiratorischen Störungen.  
In: Benzer H., Burchardi H., Larsen R., Suter P.M. (Hrsg.),  
Lehrbuch der Anaesthesiologie und Intensivmedizin. 335 – 349.
- 5 Colice G.L. (1994) Historical perspective on the development of mechanical  
ventilation. In: Tobin M.J. (Hrsg.), Principles and practice of mechanical  
ventilation. 1 – 35.
- 6 Dönhardt A. (1984) Beatmung mit der Eisernen Lunge.  
In: Lawin P., Peter K., Scherer R. (Hrsg.), Maschinelle Beatmung  
gestern – heute – morgen. 20 – 27.
- 7 Dräger H. (1917) Das Werden des Pulmotors,  
Drägerhefte Nr. 57/58. 495 – 496.
- 8 Dräger H. Lebenserinnerungen von Heinrich Dräger , Alfred Jansen,  
Hamburg (Erstdruck 1914).
- 9 Freytag K. (1970) Dräger Beatmungsgeräte. Drägerhefte Nr. 281 13 – 26.
- 10 Fürniß H. (1984) Vom Dräger Poliomaten zum Spiromaten.  
In: Lawin P., Peter K., Scherer R. (Hrsg.), Maschinelle Beatmung  
gestern – heute – morgen. 28 – 43.
- 11 Fürniß H. Hollmann F. (1955) Der Pulmotor in neuer Form,  
Drägerhefte Nr. 227.4867 – 4872.
- 12 Haase-Lampe W. (1923) Die Pulmotor-Frage im Reichsgesundheitswesen  
Drägerhefte Nr. 91.919 – 921.

- 13 Haase-Lampe W. (1924) Der Pulmotorstreit, Drägerhefte Nr. 99.1019 – 1022.
- 14 Haase-Lampe W. (1929) Pulmotor-Streit. Pulmotor-Nachrichten Nr. 1, Beilage der Drägerhefte.
- 15 Haase-Lampe W. (1930) Merkwürdige Wiederbelebungsfolge. Pulmotor-Nachrichten Nr. 4, Beilage der Drägerhefte.
- 16 Haase-Lampe W., Thiel K. (1946) Pulmotor – Sauerstoff-Wiederbelebungsmaschine für künstliche Beatmung, Antäus, Lübeck.
- 17 Hörmann Ch., Baum M., Putensen Ch., Mutz N. J., Benzer H. (1994) Biphasic Positive Airway Pressure (BIPAP) – a new mode of ventilatory support. *European Journal of Anaesthesiology* 11: 37 – 42.
- 18 Lawin, P. Opderbecke H.W. (1994) Organisation der Intensivmedizin. In: Lawin, P. (Hrsg.) *Praxis der Intensivbehandlung* S. 15 – 63.
- 19 Lellouche F, Mancebo J, Joliet P, Roeseler J, Schortgen F, Dojat M, Cabello B, Bouadma L, Rodriguez P, Maggiore S, Reynaert M, Mersmann S and Brochard L. (2006) *Am J Respir Crit Care Med* 174: 894–900.
- 20 Putensen C, Mutz NJ, Putensen-Himmer G, Zinserling J (1999) Spontaneous breathing during ventilatory support improves ventilation-perfusion distributions in patients with acute respiratory distress syndrome. *Am J Respir Crit Care Med*, 159: 1241–1248.
- 21 Rozé J.C. Krüger T. (1997) Pressure Support Ventilation – eine neue getriggerte Beatmungsform für Neonaten. Dräger, Lübeck.
- 22 Schröder H. (1913) Die Pulmotor-Organisation. Drägerhefte Nr. 15.140.
- 23 Schröder H. (1914) Dräger-Baby-Pulmotor. Drägerhefte Nr. 19.172.
- 24 Younes M. (1994) Proportional assist ventilation (PAV). In: Tobin M.J. (Hrsg.), *Principles and practice of mechanical ventilation*. 349 – 369.







## CORPORATE HEADQUARTERS

Drägerwerk AG & Co. KGaA  
Moislinger Allee 53–55  
23558 Lübeck, Germany

[www.draeger.com](http://www.draeger.com)

### Manufacturer:

Dräger Medical GmbH  
Moislinger Allee 53–55  
23558 Lübeck, Germany

### REGION EUROPE CENTRAL AND EUROPE NORTH

Dräger Medical GmbH  
Moislinger Allee 53–55  
23558 Lübeck, Germany  
Tel +49 451 882 0  
Fax +49 451 882 2080  
[info@draeger.com](mailto:info@draeger.com)

### REGION EUROPE SOUTH

Dräger Médical S.A.S.  
Parc de Haute Technologie d'Antony 2  
25, rue Georges Besse  
92182 Antony Cedex, France  
Tel +33 1 46 11 56 00  
Fax +33 1 40 96 97 20  
[d1mfr-contact@draeger.com](mailto:d1mfr-contact@draeger.com)

### REGION Middle East, Africa

Dräger Medical GmbH  
Branch Office  
P.O. Box 505108  
Dubai, United Arab Emirates  
Tel +971 4 4294 600  
Fax +971 4 4294 699  
[contactuae@draeger.com](mailto:contactuae@draeger.com)

### REGION ASIA / PACIFIC

Draeger Medical South East Asia Pte Ltd.  
25 International Business Park  
#04-27/29 German Centre  
Singapore 609916, Singapore  
Tel +65 6572 4388  
Fax +65 6572 4399  
[asia.pacific@draeger.com](mailto:asia.pacific@draeger.com)

### REGION CENTRAL AND SOUTH AMERICA

Dräger Panama Comercial S. de R.L.  
Complejo Business Park,  
V tower, 10th floor  
Panama City  
Tel +507 377 9100  
Fax +507 377 9130  
[contactcsa@draeger.com](mailto:contactcsa@draeger.com)

**As of August 2015:**  
Dräger Medical GmbH  
changes to Drägerwerk  
AG & Co. KGaA.