



ANDERSEN
STERILIZERS

ANPROLENE AN75

TABLETOP GAS STERILIZATION



Protect your patients, preserve your instruments

THE ONLY FDA-CLEARED, ROOM-TEMPERATURE GAS STERILIZER

Affordable, Versatile, Tabletop

Andersen's tabletop Anprolene® sterilizers are the most cost-effective, gentle and compatible on the market. Offering a room temperature, 100% ethylene oxide (EO) terminal sterilization cycle. When combined with our abatement system, Andersen sterilizers release a fraction of a gram of EO per cycle and less than a pound of total emissions per year – effectively making the process zero emission.

12 Hour Exposure Cycle

Achieves FDA-required 10^{-6} sterility assurance level for terminal sterilization of medical devices.

Smart Cabinet Design

A ventilation port in the back of the cabinet actively draws fresh air from the room throughout the entire cycle. Ensuring air flow in one direction and minimizing potential operator exposure.

100% EO Cartridge

Cartridge protects the sealed glass ampoule of EO. Uses only 17.6g of gas per cycle.

Process Challenge Device

Built into the purge probe handle to ensure the 10^{-6} biological indicator is consistently placed in the most difficult location for EO to reach in every cycle.

Simplified Controls

Touchscreen display makes the AN75 easy to use. Sterilization status and cabinet temperature shown throughout the cycle.

Easy Installation

Requires only a 120v or 240v outlet and a 1" exhaust line.

Sterilization Bag

Now made of gas impermeable materials to maintain consistent gas concentration throughout the cycle.

Active Aeration in Same Chamber

Andersen's purge probe flushes the liner bag with a constant flow of fresh air at the end of the cycle - no need to transfer items to a separate area. Two hours of aeration standard. EO absorbent items may require additional aeration.



Replaceable Abator Cartridge

200 cycle capacity. Spent cartridges are non-hazardous and may be discarded in most landfills or returned to Andersen for disposal.



Make Your System Zero Emissions



Andersen's optional abators are a simple, cartridge-based system that employ a dry catalyst resin. The resin converts ethylene oxide to biodegradable organic compounds.

Replacement cartridges remove more than 99% of the EO in the exhaust stream, resulting in a fraction of a gram of total EO emissions over the course of a multi-hour cycle. This tiny amount of EO is vented to the outside where it disperses rapidly, quickly becoming undetectable.



EXCLUSIVE GAS STERILIZATION TECHNOLOGY



Andersen's exclusive EO-Flexible Chamber Technology (EO-FCT) and 17.6g gas cartridge (90% less gas than any other system) combine to provide your facility with the proven reliability of EO in a modern, highly efficient package.

Innovation at work

Taking Excellence to the Next Level

Anprolene, Andersen's most popular line, has an established reputation for efficiency and dependability. Through innovations in technology and process, the next generation AN75 family achieves even more consistent sterilization results. An interactive touchscreen menu combines with component updates to provide the most versatile and effective sterilization system on the market. Now FDA-cleared, all facilities can achieve hospital-level sterility assurance (10^{-6}) at a reasonable pricepoint.

Benefits:

- Color touchscreen display
- Integrated biological process challenge device (PCD)
- Space-saving tabletop design
- Easy installation and maintenance
- Affordable
- Proven reliability
- Sterilization and aeration in the same chamber
- Free operator training for the life of the system

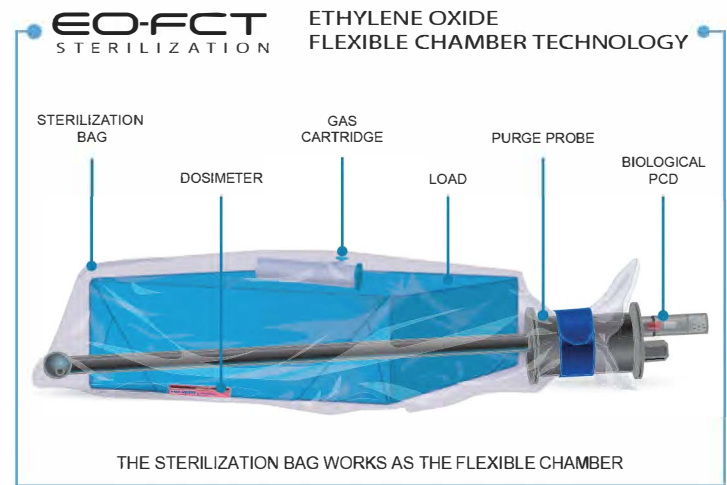

What Load and Material Types are Cleared by the FDA for the AN75?

Device Type	Maximum Load	Device Examples	Required Aeration
Metal	24 lbs (11kg)	Delicate sharps and surgical instruments, including those with hinges and mated surfaces	Metal instruments do not absorb EO. Follow pouch or wrap manufacturer's instructions (Example: Sterisheet wraps require ≥ 6 hours at 20-29°C)
Plastic	3.5 lbs (1.6kg)	Reusable power cords, trocars	Follow manufacturer's instructions: 24 hours at 20-29 °C
Fabric	3 lbs (1.4kg)	Reusable cloth gowns, towels	Follow manufacturer's instructions: 24 hours at 20-29 °C

AN75 FDA 510(k) clearance: <http://bit.ly/AN75FDA510k>

DIMENSIONS AND SPECIFICATIONS

Two affordable models to choose from

Easy to install and operate

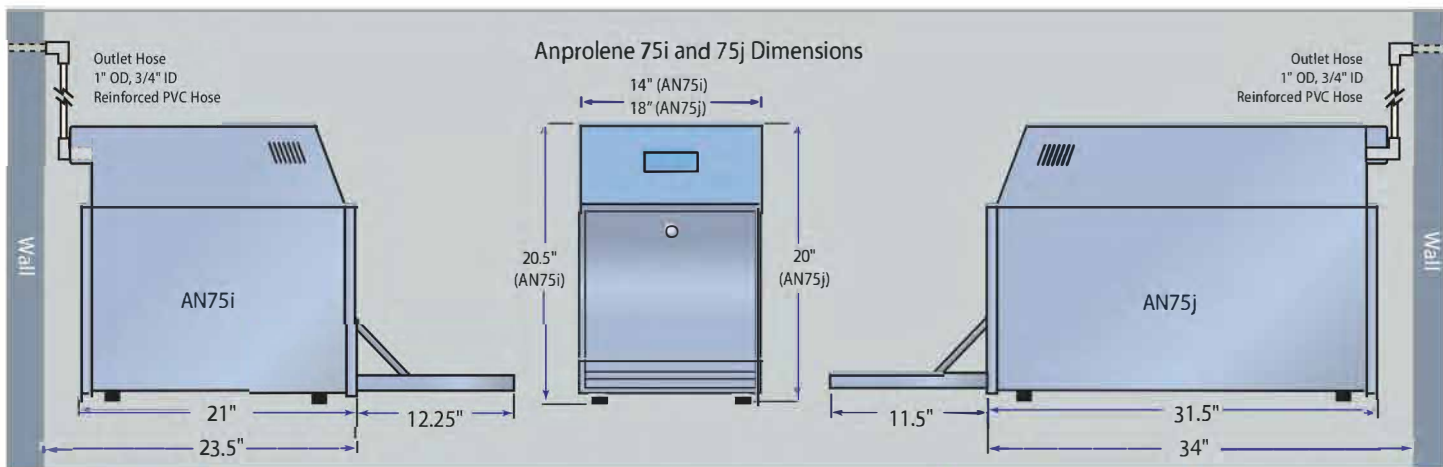

Model	Suggested Use	Interior Dimensions	Exterior Dimensions	Weight
AN75i	Space-saving design for smaller practices	19.25"L x 13.75"W x 12.75"H	21"L x 14"W x 20.5"H	56 lbs (25 kg)
AN75j	Oversized instruments, larger loads	29.25"L x 17.75"W x 12.5"H	31.5"L x 18"W x 20"H	91 lbs (41 kg)

Power Supply: 120v (240v available)

"I've used the Andersen sterilization equipment for more than 20 years. The huge cost savings component is the first reason I came to use gas sterilization"



Dr. Joseph P. Hunstad
Plastic Surgeon
H/K/B Cosmetic Surgery
Huntersville, NC



Dr. Marvin Sheinbaum
Plastic Surgeon
Brandon Plastic Surgery
Brandon, FL

"We use our AN75 for all our vaser ultrasonic equipment, radio frequency equipment, fiber optic cable and fiber optic endoscopes for facial surgery. We would not dream of putting any of that sensitive equipment into our steam autoclave. "

Andersen Sterilizers: The Future Of Gas Sterilization, Today

A leader in 100% ethylene oxide sterilization for more than 60 years, Andersen's machines are critical to the daily infection control process in thousands of clinics, veterinary and human hospitals, and industries across 75 countries. Family owned and operated, always manufactured in the United States, Andersen is dedicated to protecting your patients and our environment.



H.W. Andersen Products Ltd
Unit 808 Oakwood Business Park
Fowler Road
Clacton On Sea, CO15 4AA



www.andersensterilisers.com



#3004634710