

# Eco700 Cabin Lift

The Personal lift



Electric, ecological, exclusive.



**Premier**  
Platform Lifts  
[www.premierplatformlifts.co.uk](http://www.premierplatformlifts.co.uk)

# Eco700

## Technology

- Low energy consumption
- Noiseless, class-leading
- Carrying capacity of 400 kg, without counterweight
- MRL Machine Room-Less

## Ecological

- Without hydraulic oil
- Manufacturing process with waste materials for recycling

## Safety

- In case of power failure, back to the floor automatically
- Infrared barriers
- Communication device inside the cabin



## Customised

Many personalisation options to suit all tastes. Suitable for both indoor and outdoor installation. Quick to install with no invasive building works

## Design

Our focus on styling is expressed through the shapes and materials chosen to express wellbeing attention to details, and a love of our work



**Quality**  
In Premier Platform Lifts products, quality means substance: reliability, quiet operation, user-friendly technology

The Eco700 lift fits into any domestic context with discretion and elegance. It is a 100% Italian product, and every installation clearly reflects its membership of the world-famous Italian design and styling tradition.



**Experience**  
Premier platform Lifts are the market leaders, and have been designing and building tailor-made installations to improve quality of life for all access needs, both in the home and in public buildings, for many years.



# CABIN WALLS COLOURS

## COLOUR SERIES



Grey  
standard



Beige  
standard



Blue  
standard



Red  
standard



Special RAL  
colour

## GLASS SERIES



Transparent

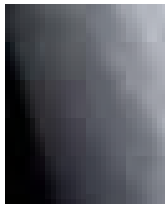

Smoked

## WOOD SERIES



Maple  
standard



Cherry  
standard

## STEEL SERIES



Platinum



Linen Polished

## STAINLESS STEEL SERIES

# CABIN PLATFORM COLOURS

## RUBBER SERIES



Grey with  
stamps

## SAFE STEP SERIES



Light grey

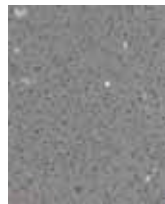

Dark grey



Red

## WOOD SERIES



Wild Pear

## RAL COLOURS



RAL 7040  
standard



RAL 1013

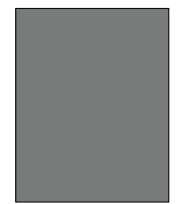

RAL 9023



Special RAL

# DOORS & STRUCTURES

Premier Platform Lifts offer you many customisation options, starting from the walls of the cabin, available in different finishes & colours, through the platforms, in fine materials in a variety of shades. A wide choice of structure finishes are available to provide the best match with the surrounding colours and environment.

# ACCESSORIES DOORS



Double hinged, in glass, for an elegant, stylish effect



Blind hollow veneered



Fully automatic cabin door for "Single Touch" operation

2 alternative colours



Stainless Steel



Special RAL



Panoramic, in aluminium; lightness at hand



Hollow veneered with viewing



Infrared sensors all around the perimeter for entry/exit from the cabin, to guarantee full safety.

## Handles



Series Rich

## ACCESSORIES CONTROL PANELS

The technological content and choice finishes make the cabin a pleasant place to be, with comfort and safety, at all times.



On-board control Panel

- A) LCD display with travel indicator
- B) Telephone speaker
- C) Dark blue backlit buttons with Braille
- D) I-button, for electronic access control
- E) Alarm button



Floor control panel

- A) LCD display with travel indicator
- B) Call button: green when lift is free, red when busy
- C) I-button, for electronic access Control

## Cabin lighting

LED bar standard 2 led lamps



# Eco700 Traction Lift

## The right choice, the choice of taste

■ Eco700 lift gives added value to all homes through simple tailor-made installations, both indoors and out. Available in versions from two to five floors, it is an ideal system both for renovation projects and for new buildings: no masonry works are required.

### ■ Convenient, effortless

Quiet and discreet, it is absolutely convenient even for transporting the shopping, child buggies, and any other heavy or bulky item from one floor to another within the home. With the Eco700, getting around the house could not be easier.

### ■ Customisable

You and your home deserve a lift which is tailored to suit you not only in its functions but also in its design and personalised finishes; the colours and trims available ensure your Easy Living is just as you want it, the perfect match for its context and your taste.

### ■ Reliable

Premier Platform Lifts technology guarantees you a product at the state of the art from every point of view. Our comprehensive warranty allows you to cut servicing costs and enjoy all the benefits of quality construction.



Sensations  
Getting onto a Premier lift  
gives you a feeling of  
comfort and safety, and  
using it will  
become a natural part of  
your daily life.





## Eco700 with structure

The Eco700 lift has state of the art structures in terms of strength, versatility and design. These structures can be customised with different types of glass panelling to suit installations of all kinds, with tailormade versions and installations even in particularly difficult contexts.

A Premier outdoor lift never requires invasive building works: installation is completed quickly and with great care, thanks to a network of skilled installers always up to date with the latest products and techniques.



# TECHNICAL DATA

The Eco700 technical package has parameters and functional requirements of the highest order.

**Eco700 is a unique elevator:**

- **Environmentally friendly-electric lift compliant with the requirements of the Machinery Directive 42/2006**
- In the event of a power failure automatically returning to the floor
- **Without counterweight, direct unique belt drive system**
- **MRL Machine Room-Less**

- **Load-bearing** roof (120 kg)
- Safety stop in the pit with electronic monitoring and visual flashing alarm with manual reset
- Mechanical safety lock in the headroom with surveillance (electric lock)
- O.S.G. Over Speed Governor: a **speed limiter**
- Loose control drive belts with electric monitoring and shutdown
- O.L.C. **Over Load Control:** Lock and load control equipment
- In case of power failure, electric emergency operation (Battery 36-Volt)
- Easy maintenance directly inside the cabin by moving the control panel

Eco700 traction cabin elevator	
<b>Capacity</b>	up to 400 kg
<b>Maximum travel</b>	5 stops (about 14,6 m)
<b>Speed</b>	0.15 m/sec

## INSIDE THE CABIN:

- Infrared barriers on each side of door opening for safe operation
- Device of communication with outside the cabin
- Over Load indicator
- 50 x 50 mm buttons with mechanical shutter and indication of the floor in addition to standard Braille
- On board controls height compliant to EN81-41
- Illuminated buttons (with colour identification of the function)
- Emergency Button
- “Energy saving” LED Bar lights
- On board push-button panel with dead-man’s controls-always equipped with infrared photocells barriers
- “Single Touch” operation (universal manoeuvre) due to fully enclosed cabin

## GENERAL FEATURES

- Drive system and at-the-ground control
- Single, Through and Adjacent configurations
- Drive motor 1.5 kW three-phase 220 V 50 Hz
- Single-Phase Inverter Control In / Out Phase 2.2 kW
- Electric Traction – Belt Drive
- Arrival and departure with soft start/stop system
- **Voltage supply 24 V DC**
- Mechanical key enabling on-board keypad
- No. 6 accesses maximum
- No. 2 accesses to the floor maximum
- Electrical Safety Locks
- On floor controls with “Simple touch”
- 120 mm pit - 140 mm with supporting structure
- Technical Dimensions (engine, belts) 310 mm
- Headroom minimum standard 2600 mm
- Bespoke platform sizes, almost any size available
- N ° 10 standard platform sizes available:
- 3 Standard: 1440 x 1170 - 1400 x 1100-1250 x 1000
- Option No. 8: 900 x 900 - 900 x 1250-1000 x 1400 - 1000 x 1250 - 1100 x 1400-1250 x 900 to 1250 x 1250-1400 x 1000

## OPTIONS

- I-button (electronic key) to manage independent accesses
- Voice announcer to the incoming floor
- Gong to the incoming floor
- Auto dialer with 5 numbers in memory
- Display in the car
- Display on the floor control panel
- Handle for use in public places and for people with disabilities
- Telescopic centre and side opening doors
- Horizontal Mirror
- Vertical mirror

## STANDARD CONFIGURATION

- Cabin with “colour series” grey walls (alternative choices: Beige, Red, Blue, Maple, Cherry)
- Platform “Rubber series” with grey stamps
- On-board and on the floor 50 mm buttons with Braille, without display
- “Energy Saving” with LED bar ceiling
- 800mm side opening Telescopic doors - RAL 7040

Data are guideline and not binding. Premier Platform Lifts reserve the right to make any changes it considers appropriate.

# DIMENSIONS AND OVERALL SPACE REQUIREMENTS

## MASONRY SHAFT

### Single Entry/Exit

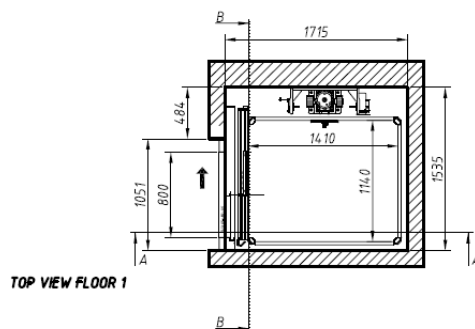
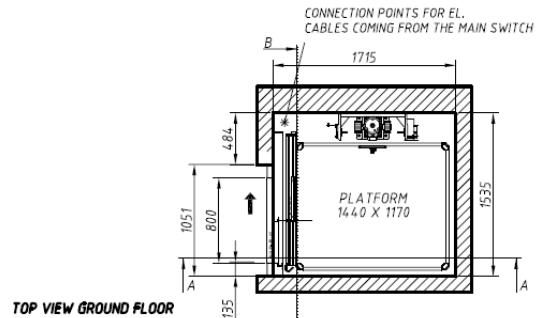
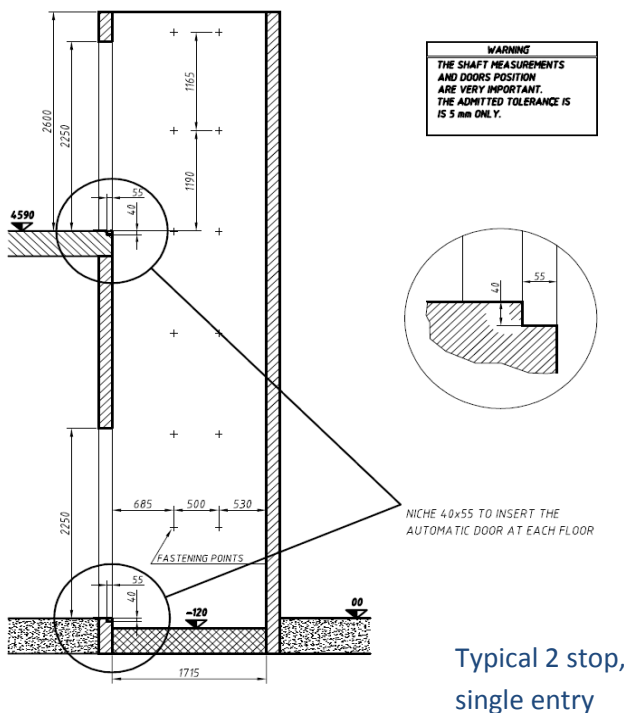

### Through Entry/Exit

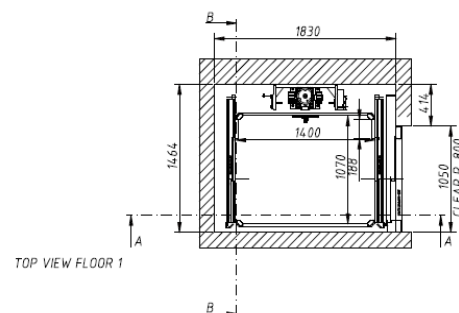
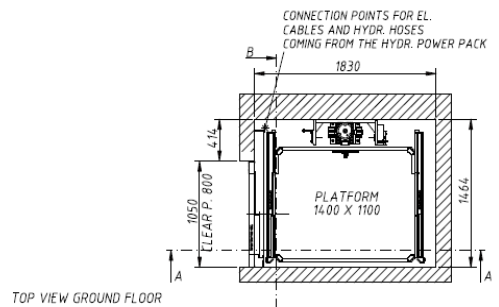
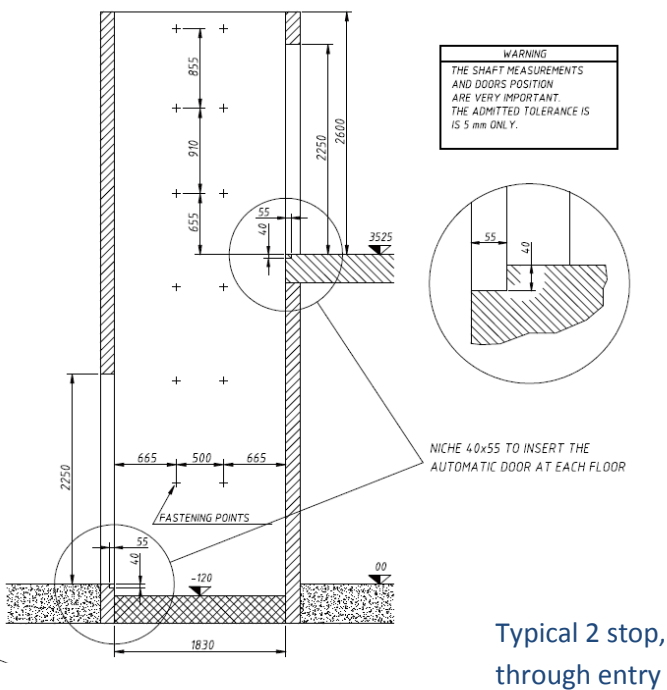

# SELF SUPPORTING STRUCTURE

## Single Entry/Exit

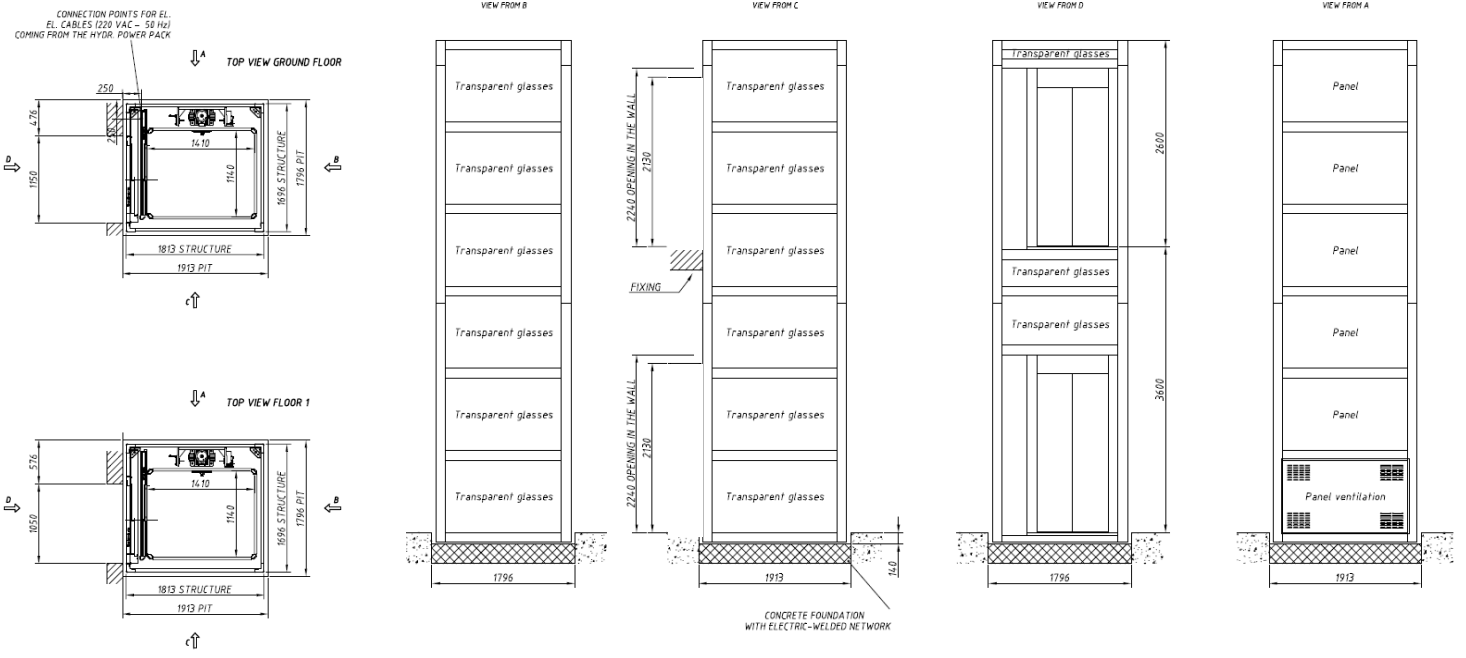

## Through Entry/Exit

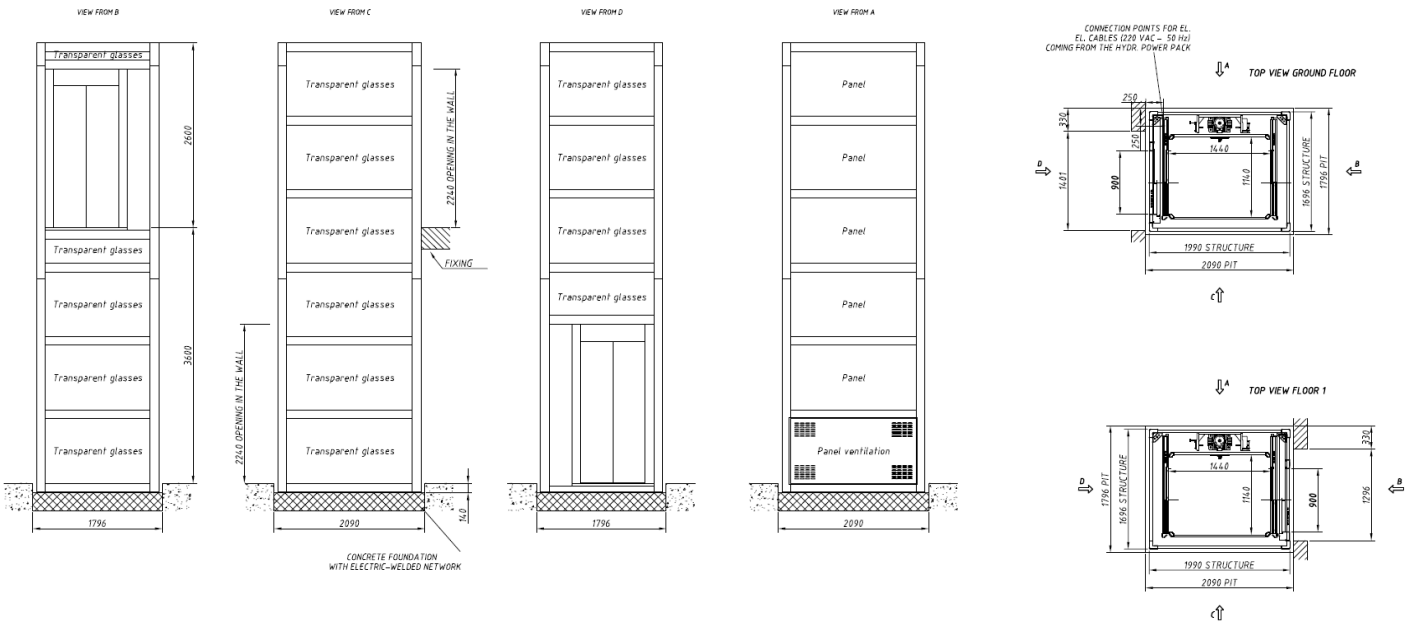





### **Guaranteed product**

The Eco700 elevator by Premier Platform Lifts is guaranteed for 12 months from the date of final commissioning.

### **PSP: at partners' service**

Partner Support Program: A Manufactures exclusive for its partners, aiming to supply each of them, all over the world, with a series of personalised tools for developing their business and offering the end user a better and more comprehensive service. This programme includes an introduction to the concepts of “accessibility”, specific classroom training courses and training in the field for sales staff and engineers, analysis and assistance for the development of the most appropriate market strategies, and backup for the organisation of seminars (e.g. for architects, civil engineering firms, etc.) and for participation at trade fairs. Close cooperation with its partners guarantees constant improvement of its degree of knowledge of the various markets and thus of their varying needs in terms of accessibility, which translates into the design of suitable products. All oriented towards better management of customer relations, and the achievement of full customer satisfaction.