

Performance Staging and Raised Flooring



Who we are

Portable staging from Stage Systems creates temporary performance platforms. Simple designs from kits, standard stock or bespoke solutions produce excellent results with flat, multi-height and tiering systems.

We are dedicated to staging and deliver on bringing spaces to life with creative designs in primary and secondary schools, colleges and universities, conference centres, hotels and businesses as well as churches, halls and community centres.

First to develop the portable staging market, we set the standard for quality, versatility and service back in the 1960s. Today we continue to share our stage solutions.

Stage Systems are part of Hoseforma Staging Ltd with offices based in Loughborough, Leicestershire which are perfectly placed to provide deliveries across the UK and Overseas. We have a team of expert Sales Advisers, an in-house Design Department and provide product demonstration services.

Our staff are dedicated to staging and have the expert knowledge to provide a solution for your performance space.

Our Products

Our products are based on a modular design, creating a single or multi-level platform with a variety of finishes and accessories. An advantage of our equipment is that it is flexible to use, a school hall can be transformed into a theatre in a short amount of time, as the systems require no tools to build. With easily handled components, each stage fits together in a variety of combinations making our staging easy and quick to build and dismantle with storage on a wheeled trolley.

Our range includes modular flat, multi-level and tiered staging.

Our Clients

We work closely with our clients to achieve the best solution for any budget and space. Over the past 50 years we have been one of the chosen staging suppliers for the education, community and commercial sectors.

Our key objective is to provide excellent customer service, to understand their requirements and assist in making the most of any performance space.

Our Services

Offering FREE, no obligation demonstrations in the UK.

We will arrange a personal visit to your establishment, to enable you to handle the equipment, discuss your requirements and survey the space available.

During the visit we will demonstrate:

- The ease of build (no tools required)
- Range of finishes
- Available accessories such as handrails
- Reversible decks to give alternative finishes
- Different layouts and configurations
- The strength and versatility of the product



Performance Staging and Raised Flooring

Multi-dek is based on modular components, constructing a single and multi-level staging system. The system can be used as a portable stage, a semi-permanent stage, a stage extension, an orchestra pit infill and raised flooring. More of our Multi-dek example installations can be found on our website in the Case Studies section.

Multi-dek[®]

performance staging

Multi-dek highly versatile staging – perfect for dynamic performances and live music events, both indoor and outdoor.

Why Choose Multi-dek?

- Tool free build
- Simple assembly
- Excellent performance strength (load bearing tested to 7.5Kn/m²)
- Achieve a variety of layouts from one kit
- Suitable for staging, flooring, raised floors, infill etc.
- Compact wheeled storage (fits through a single doorway)
- Reversible decks (please refer to the finish options)
- 10 year product guarantee
- Bespoke design and consultation service
- Low noise intensity
- Construct a large area in a small amount of time

Festival Performance Staging



University Graduation Staging



“ Graduation ceremonies could offer wheelchair access, stepped access, and a large carpeted stage area, helping to transform the hall into an amazing graduation event space.”

Loughborough University



Design and Consultation Service

Following our initial survey, your Sales Adviser will consult with our Design Department to provide the best solution, this will be in the form of a full written quotation and a set of technical drawings for your approval.

We are on hand to answer any questions you may have regarding the quotation and will be happy to carry out a second visit should this be necessary (installation and training is available on request).

Multi-dek can also be used to create wheelchair access ramps and flooring in areas such as stadiums or at the side of a staging area. We designed and installed the wheelchair access at the Principality Stadium in Cardiff.

Mezzanine or raised flooring can be designed using our Multi-dek system due to its robust and durable nature. Adjustable feet can be supplied to allow for uneven floors and the system can be designed to specific measurements.

“The modular design allows for different sizes and formations of staging to be created, compact storage is intrinsic to the design and a variety of accessories means the staging can adapt for different uses.”

Loughborough University



Installations



Loughborough University, Leicestershire



Brentwood School, Essex



The Gateway, Aylesbury



Katzenjammers, London



Kneller Hall, MOD, Orchestra Pit Infil



New Walk Museum, Leicester



East Leigh School, Hampshire

“ Multi-dek is so versatile, it can be a conference podium by day and cabaret stage by night.”

Crowne Plaza Hotel, Liverpool

Build a performance stage with just 3 components!

Multi-dek[®]
performance staging

Leg Frames



Decks



Brace Rails



Performance stage kits and components



Kit 1 components

- 8 x reversible deck panels (1209mm x 1209mm 30mm thick birch ply)
- 15 x frames (600mm high)
- 7 x brace rails
- 3 x 30mm trim
- 1 x incremental step unit
- 8 x handrails
- 2 x handrail corner brace
- 9 x handrail brace and pin
- 1 x step handrail
- 1 x multi-dek trolley



Kit 2 components

- 15 x reversible deck panels (1209mm x 1209mm 30mm thick birch ply)
- 24 x frames (600mm high)
- 14 x brace rails
- 4 x 30mm trim
- 1 x incremental step unit
- 11 x handrails
- 2 x handrail corner brace
- 12 x handrail brace and pin
- 1 x step handrail
- 2 x multi-dek trolleys

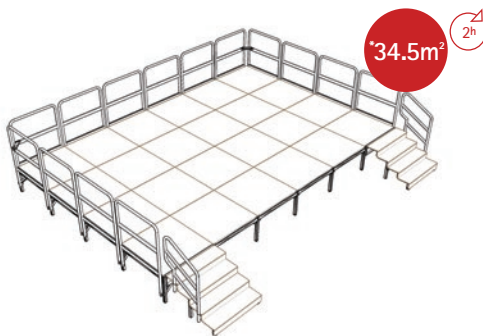

Kit 3 components

- 24 x reversible deck panels (1209mm x 1209mm 30mm thick birch ply)
- 35 x frames (600mm high)
- 23 x brace rails
- 4 x 30mm trim
- 2 x incremental step unit
- 14 x handrails
- 2 x handrail corner brace
- 15 x handrail brace and pin
- 1 x step handrail
- 2 x multi-dek trolleys

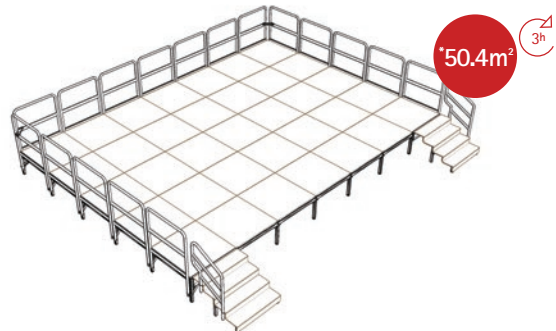

Kit 4 components

- 35 x reversible deck panels (1209mm x 1209mm 30mm thick birch ply)
- 48 x frames (600mm high)
- 34 x brace rails
- 5 x 30mm trim
- 2 x incremental step unit
- 17 x handrails
- 2 x handrail corner brace
- 18 x handrail brace and pin
- 2 x step handrail
- 3 x multi-dek trolleys

*All stage measurements are approximate.

Accessories Information

Standard deck panels are 30mm thick with a load bearing to 7.5KN/m². They are UK manufactured to a composite hardwood ply skin and a softwood core, with a UV-cured clear slip resistant acrylic lacquer.

The decks are reversible allowing a variety of finishes such as plain one side and stained/painted, vinyl covered or carpeted on the reverse.

Complement your stage with an accessory such as colour co-ordinated skirting and/or fascia.

Skirting is magnetic and fits quickly and easily to the stage trims. Fascia panels simply hook directly onto the stage frames.

Handrails/safety rails are designed to comply with BS6399-1 1996.

Trims simply push into the top of frames to finish the perimeter of the stage.

Leg extensions allow the stage to be constructed to different heights, for example:

Heights available: 336mm / 486mm / 786mm / 936mm / 1086mm / 1236mm

Step Units

Incremental step units are available in two step modules for maximum versatility (see the technical drawings section of this brochure). This enables steps to a 150mm height increment to be accommodated.

Accessories and Finishes



Skirting



Wooden fascia



Step skirting



Steps



Step handrail



Handrails

Accessories and Finishes



Reversible decks



Trims



Leg brace



Foot cups



Brace rails



Storage Trolley



Accessories and Finishes

Carpet Colours

Iron Duke - Heavy Contract Carpet



Charcoal*



Flint*



Petrol Blue*



Violet**



Willow**



Forest Green*



Blue Moon*



Chestnut**



Claret*

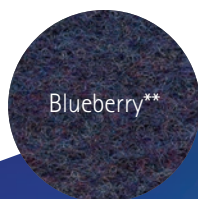

Blueberry**



Blue**

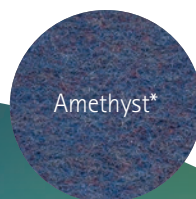

Amethyst*

Skirting Colours

Accolade Dimout - Flame Retardant Dimout Curtaining

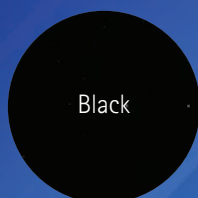

Black

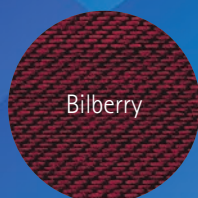

Bilberry

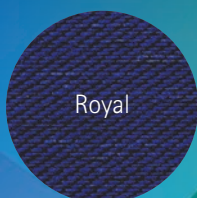

Royal



Kingfisher



Ruby

Every effort has been made to ensure a true colour likeness, but this may vary according to screen and printer settings. Please contact us to request a swatch sample.

*4 weeks delivery time. **4-6 weeks delivery time..

Quality Finishes

Shown below are some examples of the various floor finishes and materials available. We can accommodate other specifications on request.

Birch Veneer

with Iroko hardwood edging.
Water resistant material to the underside of the deck

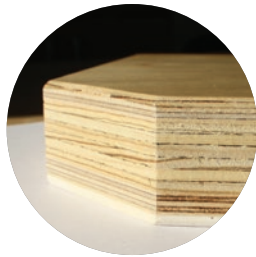

Phenolic

non-slip resin



Accoya

In a choice of finishes



Multi-dek

technical specification

Outline Specification

Decks

- Standard reversible deck panels are 30mm thick. They are composite of 2 x 3mm birch skins with a 30mm spruce core. Suitable for a distributed loading of 7.5kN/m².
- Standard finish - None-slip, UV cured or flooring grade emulsion finishes.
- Optional finishes include carpet covered or flooring grade emulsion finishes.

Frames

- ERW steel tube or 316 stainless steel
- Standard finish - gold passivated bright zinc plate.
- Optional finishes - clear passivated bright zinc or epoxy powder coated in a range of colours.

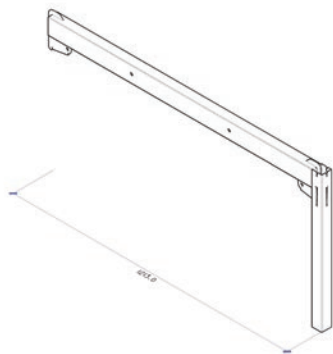

Leg Frame

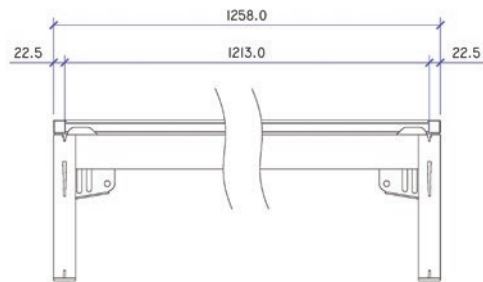

Multi-dek module overall sizes

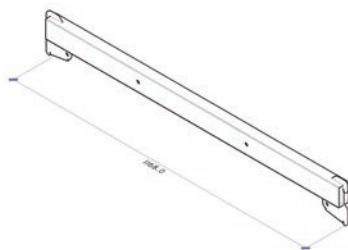

Brace Rail

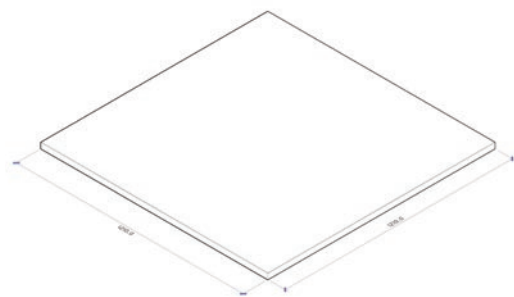

Deck

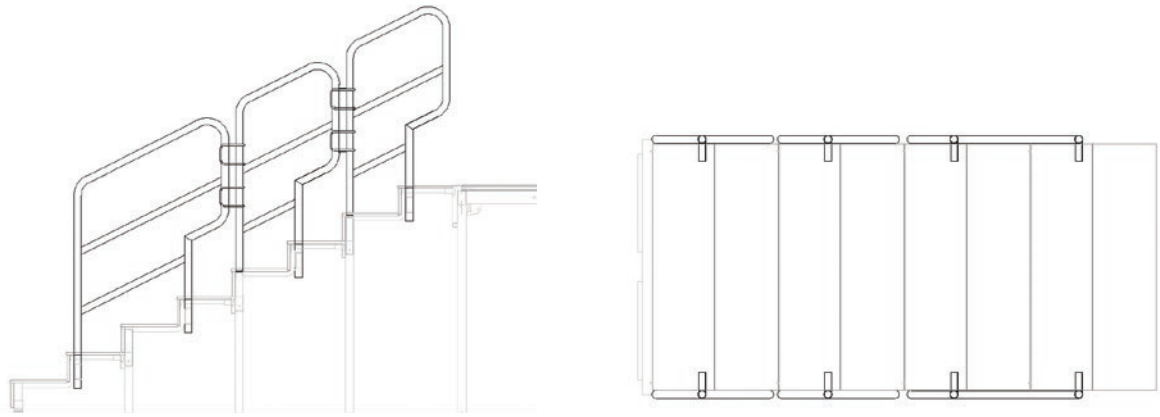

Handrails configuration

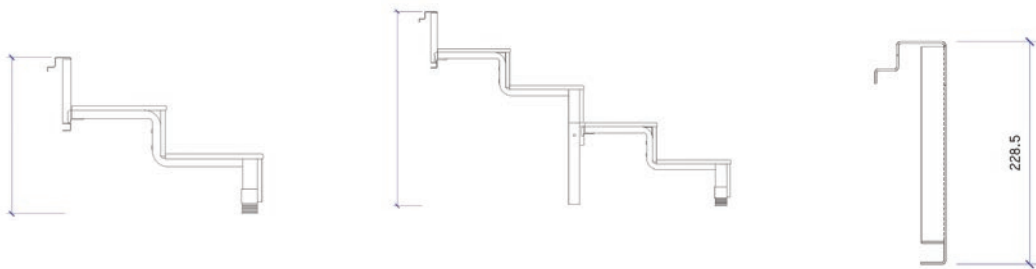

Step Module Configurations
Available in varying heights from 336mm to 1236mm

Step Adaptor



“The joy of this first class system is it’s so easy to assemble and dismantle so is put up the night before and taken down after the performance.”

Neil MacLachlan

Frame

Leg Frame Height	Standard heights include 336mm/486mm/ 636mm/786mm/936mm/1086mm. Each frame can be used in conjunction with each other to produce level and multi height layouts. (Bespoke sizes can be provided)
Leg Frame	45mm x 45mm x 2.5mm wall ERW steel tube
Brace Rail	40mm x 70mm x 2.5mm wall ERW steel tube
Finish	Gold passivated bright zinc plate
Foot Bungs	Low Density Polyethylene

Deck

Size	1210mm x 1210mm x 30mm (Bespoke sizes and shapes are available)
Material	18mm spruce core with 2 x 6mm BB/BB birch plywood skins
Finish	UV coated with slip resistant acrylic lacquer as standard. Other options include carpet and black emulsion floor paint.
Versatility	Can be reversed.

Step/Handrails

Size/Material	Ø38.01mm x 2.03mm wall ERW steel tube
Height	Nominal 1100mm above deck
Finish	Gold passivated bright zinc plate/clear passivated, bright zinc or epoxy powder coated in a range of colours (optional).
Attachment	Connects into frame with brace and pin and corner brace when necessary.

Steps

Materials	15mm BB/BB birch plywood/Mild steel framework
Height	Step modules in 150mm rises to suite stage
Finish	UV coated with slip resistant acrylic lacquer as standard. Other options include carpet or black flooring clear lacquer grade emulsion / Gold passivated bright zinc plate as standard.

Certification

Structure	Temporary Demountable Structures: 2nd Edition BS6399: 1996: Part 1: Loadings for Buildings.
Carpet	Heckmondwike 'Iron Duke' heavy contract broadloom carpet, 5mm, Tested to BS5287 for flammability
Skirting & back drapes	Accolade. Inherently flame retardant 'dim out' curtaining conforming to BS5867 Part 2:B
Vinyl	Rosco floors, black/grey, 1.3mm, fire resistance NFPA701

Miscellaneous

Bespoke	Multi-Dek can be adapted to fit perfectly into a specific space, whether the space is an irregular shape, has an uneven floor or there are obstacles such as pillars, steps or supports.
Bespoke Accessories	Different carpet finishes, split level, cable ports, fascia panels, special trims to deck edges and step treads.
Guarantee	All standard components are guaranteed for 10 years
Service	Commissioning of equipment, user training and O&M manuals provided where necessary



Here are a sample of customers we have designed and installed Multi-dek for:

Education

- Mulroy College
- Woodlands School Derby
- Walworth Academy
- Torquay Academy
- Magnus Church of England Academy
- Incerclyde Academy
- The Regent's University
- Peterhead Academy
- Hill House International Junior School
- Kings Place Music Foundation

Commercial

- Kings Place Music Foundation
- Red Car Pubs
- Rathfriland Young Farmers Club
- Warwick Business School
- RAF Valley
- Spitalfields Market
- The Coronation Hall
- Crockfords Casino

Religious Establishments

- Church of Christ the King, Greenwich
- Silsden Methodist Church
- St Andrew's Hall, Lewisham
- Market Rasen Methodist Church, Lincolnshire
- New Springs Church, Leicestershire
- Sandal Methodist Church, Wakefield
- New Life Christian Centre, Croydon

Community

- Salvation Army – Cardiff
- Riding Mill Parish Hall
- Wetheral Community Association
- Little Walktham Village Hall, Essex
- Grizebeck Community Hall
- Treuddyn Village Hall
- Craven Players
- Alston Moor Dance School
- Lake District Summer Music

“It’s comforting to know we’ve invested in a stage that has the capability to transform our auditorium into something entirely different...”

Flat stage used in a multi-media auditorium. “The drum”

For friendly, expert advice call

01509 611021

E: info@stagesystems.co.uk F: 01509 233146

www.stagesystems.co.uk



✓ A complete staging solution



T: 01509 611021 E: info@stagesystems.co.uk F: 01509 233146 www.stagesystems.co.uk

Part of Hoseforma Staging Limited

