

Staging Hire

All you need to know about our hire service

Q-plus[®]
modular tiering



For friendly, expert advice call

01509 611021

www.stagesystems.co.uk



Q-plus

The construction of Q-plus is simple, using a rectangular frame that supports individual deck panels which can be used to create staging and tiering for performance, together with audience seating.

“Q-plus can be configured into single or multi-level layouts. Suitable for standing or seating”

Components



Frame heights



Tie plate



Frames



Frames with decks



Multi height



Kits

Kits offer multi-level stages which consist of frames, decks, steps and storage trolleys.

- One kit - multiple layouts
- Simple wheeled storage
- Quick and easy build - no tools required
- Modular multi-level and flat staging
- Reversible decks - carpet / birch
- 15 year guarantee
- Accessories available
- FIRA tested for loading (7.5Kn/m2) & stability
- UK Manufacture

Additional dressing options such as skirting and safety rails are available.

The carpeted kit shown below demonstrates a variety of layouts achievable. The kits include a combination of 277.5mm and 500mm high frames, which enable multi-level and flat stages.



Flat layout (carpeted)



Catwalk



Multi-level



Tiered levels

Additional Accessory Options

Various accessories are available to enhance your stage.



Vertical bar safety rail

Safety rails are available with vertical bars and slot into the decks to provide a safety barrier at the edge of the staging or step.



Double tread step

Steps provide access to the stage. Double tread steps are included in the kits.



Storage trolley

Storage trolleys provide ease of transportation and compact storage (included with kits).



Skirting

Black



Black skirting complements any stage layout.

Skirting Features

- 50% gathering included in length
- Fire resistant fabric
- Machine washable
- Magnetic fixing to frames

Finish Options

The standard deck finish is a clear non-slip lacquered birch with a reversible charcoal carpeted deck.



Q-plus Technical

Units are made from 3 simple parts: metal frame, tie plate and wooden deck. Q-plus dimension is 750mm x 900mm

- Standard frame finish is dabble (a speckled mid grey, polyester powder coating to mild steel).
- ERW Steel Tube
- Glass filled nylon insert

Decks constructed from quality birch plywood, UV cured with slip resistant acrylic lacquer as standard.

Staging exceeds BS6399 requirements for loading: 7.5kN/m² or a minimum of 5kN/m² (for large, tiered layouts).

All standard components are guaranteed for up to 15 years.

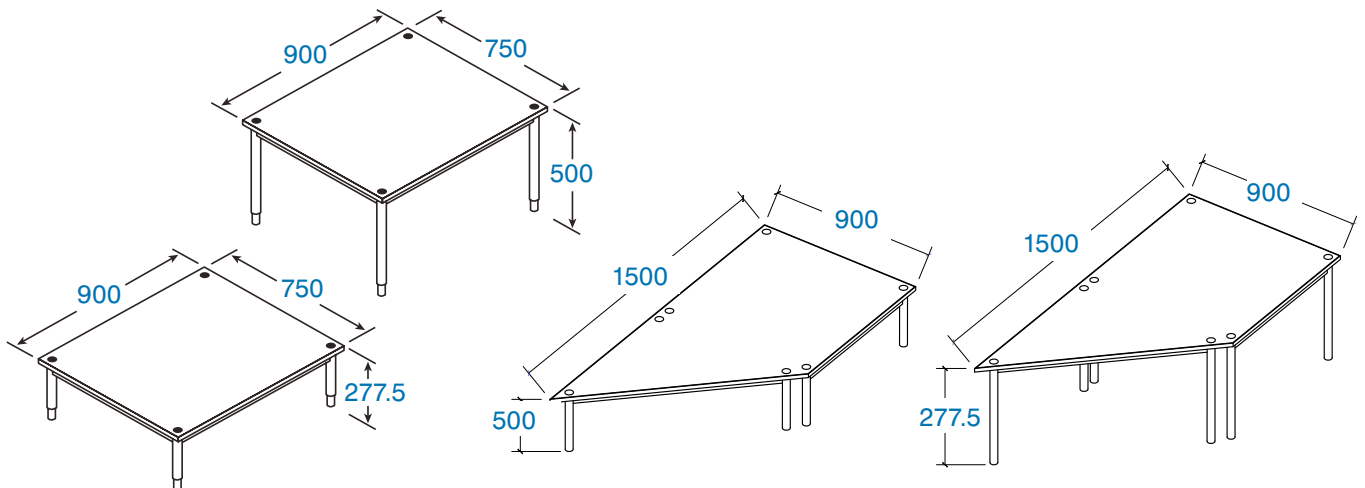

Safety Rails

Standard frame finish is dabble (a mid grey, polyester powder coating to mild steel).

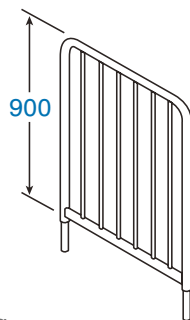

All sizes are in millimetres.
1100mm high handrails are available.

Step Units

Mild steel and birch plywood. Double tread step handrails are available.

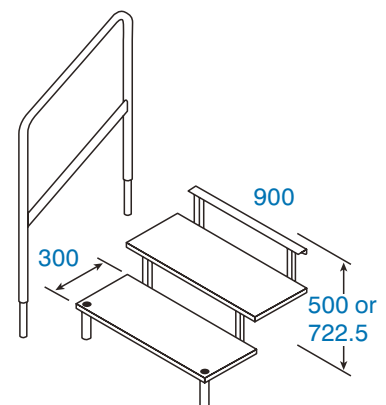

For friendly, expert advice call

01509 611021    

E: info@stagesystems.co.uk F: 01509 233146

www.stagesystems.co.uk

