

# MODULAR

## vertical access ladders

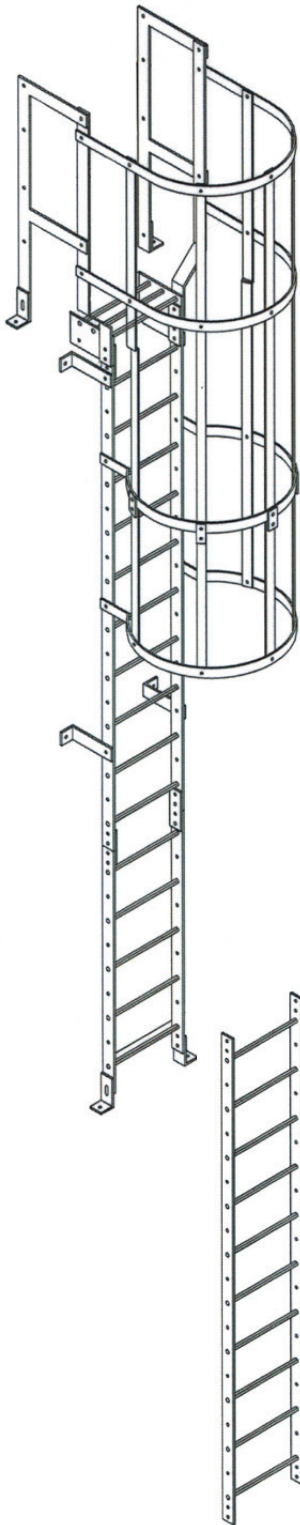

Our access ladder kit is a safe, simple to install modular ladder system that consists of individual components that easily bolt together to form a BS4211 compliant ladder.

All of the components that make up the ladder system are designed to comply with BS4211 and are manufactured from durable lightweight aluminium, for ease of assembly and installation. Supplied and delivered direct to site in a flat pack form, complete with comprehensive installation instructions, the ladders are easy to install and adapt using the minimum of tools. The convenience of using a modular system eliminates the need for site specific construction drawings and can speed up the process from specification through to installation.



### Flexibility

Using different combinations of modular ladder system components and hoops, any height of ladder can be produced to solve virtually any access issues.



### Durability

All ladder system components are manufactured from durable, lightweight aluminium and all fixings are manufactured from stainless steel.



### Simplicity

No need for cranes or heavy lifting equipment. The ladder system is delivered on a standard pallet and can easily be installed by two men.



### Security

Once installed, the combined ladder system is designed to be fully compliant with BS 4211

