



European Standard Medical Gas Terminal Units

Easy to Install and Maintain

BeaconMedæS terminal units provide a convenient connection at the final delivery point of a facility's medical gas piping system.

A two component design provides for easy installation of units.

- Base Blocks are permanently installed to the gas distribution pipeline. Multi configurations can be easily located in walls, bedhead trunking, headwalls, or as fixed pendants.
- Sockets couple with the base blocks to provide users with gas specific outlet connections. A unique design for sockets insures profile of sockets is always installed in the correct position.

The two component design also allows socket to be easily removed for service to the unit.

Reliable Gas Service

BeaconMedæS terminal units accept gas specific probes with multiple configurations. Design allows probes to be easily connected and disconnected with single-handed operation. Sockets are color coded for easy identification of service.

Gas specific terminal units comply with European Directive 93/42/EC governing medical devices to ensure non-interchangeability among different gases. Terminal units are designed and manufactured in accordance with EN 737-1 for medical gas distribution systems and conform to gas specific dimensions and connection requirements as found in the following standards.

- DIN 13260-2
- ENV 737-4
- ENV 737-6
- NF S 90-116
- NF S 90-119
- SS 875 24 30
- UNI 9507

Quality Design and Construction

BeaconMedæS has over 40 years experience designing and manufacturing medical terminal units – with over a million units in service globally.

Our units are constructed with quality, heavy-duty materials. Detail and precision provide for strong and secure connections. Every unit is 100% tested prior to shipping to ensure performance that exceeds your expectations.

Units have CE marking and comply with Medical Devices Directive 93/42/EC and are classified as Class IIb Medical Devices.



Socket & Probe for Air Service to DIN 13260-2 Standards



Socket & Probe for Oxygen Service to AFNOR NF S 90-116 Standards

Life
is in the
details.





Base Blocks

Base Blocks are available in multi-configurations for placement into

- Walls
- Bedhead Trunking
- Headwalls

Units are also available for use with fixed pendants.

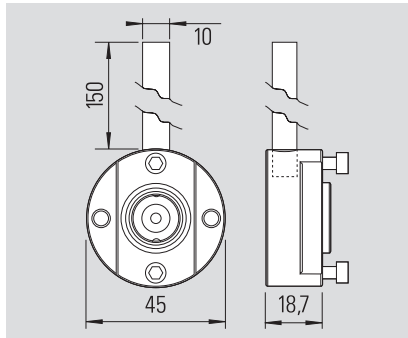

Vertical Inlet – Straight Pipe

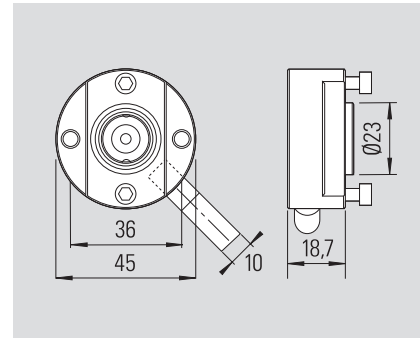

45° Inlet – Straight Pipe

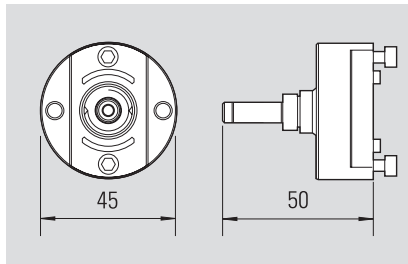

Back Inlet – Barbed Connection

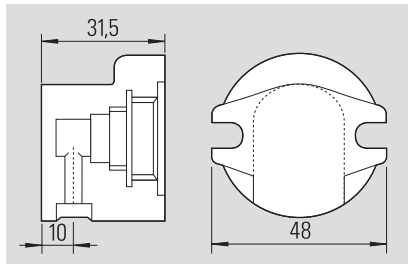

Vertical Inlet – UNI Style

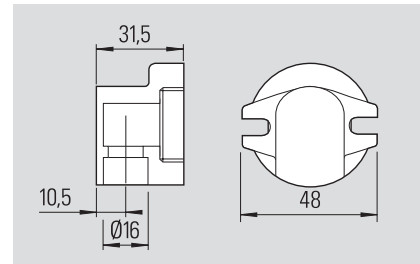

Vertical Inlet – AGSS

Sockets

Sockets are Gas Specific and are available for multiple European Medical Gas Standards.

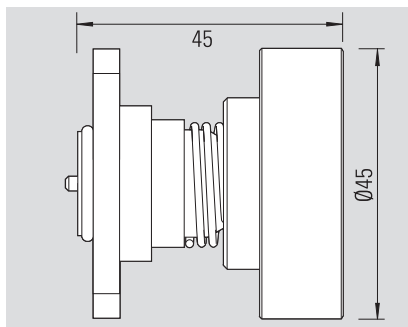

DIN 13260-2

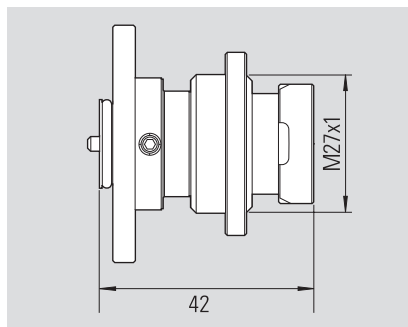

NFS 90-116

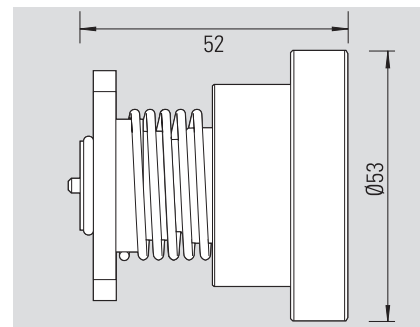

ENV 737-4

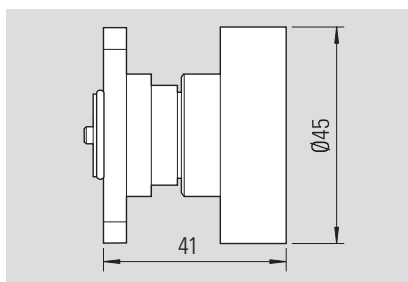

SS 875 24 30

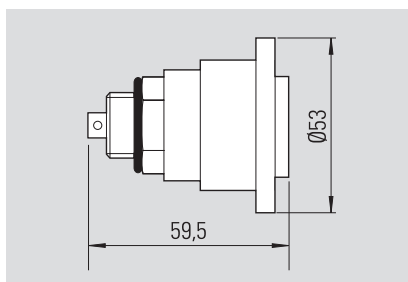

UNI 9507

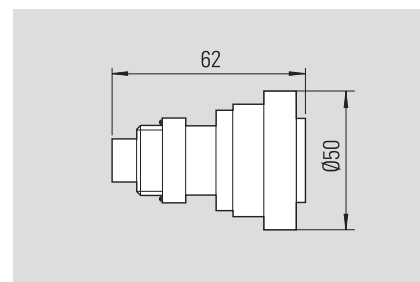

AGSS Systems

Probes & Adapters

Probes are available in multiple configurations to accommodate facility's needs and for easy connection to medical devices and equipment.

Mounting Boxes

Mounting boxes provide finished look and are suitable for either flush-mounted or surface-mounted applications.

BeaconMedaes

Part of the Atlas Copco Group
Telford Crescent, Staveley,
Derbyshire, S43 3PF, England
Tel: +44 (0) 1246 474 242
www.beaconmedaes.com

