



ALIEN130

Alien-130 stand alone or modular set



APPLICATIONS

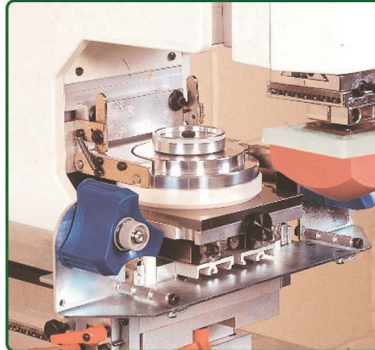

Stand alone with pad cleaning



Turn 90° for easy pad/plate change

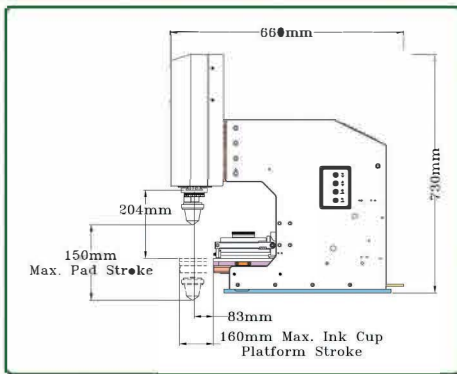

Alien on turn table



Alien-in-line

FEATURES

- A high speed, user-friendly pad printer
- Rigid aluminium casting machine frame
- Pneumatic pad stroke
- Use sealed ink cup set up
- Compatible with long life, economy of Green plate, 10 mm steel plate, thin steel plate and polymer plate
- Dead-on printing plate registration for quick job change
- Fast setup, snap-on plate change
- Automatic pad cleaning with programmable cleaning cycle
- APS : Automatic pad stroke by optical scale
- Special functions: double ink / print cycles, dwell and delay before print
- European safety CE standard
- RS-232 communication system
- Hardened ground steel shaft with impregnated bushing ensure friction-free movement
- High speed and smooth machine operations

SPECIFICATIONS

Ink cup size :	Ø130 mm
Plate size :	150 x 300 mm
Max. print Ø for ink cup :	Ø120 mm
Pad stroke :	0-160 mm (200 optional)
Speed : *	2,500 cycles/hr.
Max. pad pressure :	1,178N
Power :	110/220V 50/60Hz 30W
Air consumption :	5.8 litre/cycle
Size : L x W x H	660 x 220 x 730 mm
Weight :	65 Kg (approx.)

* Please note that actual output may be affected by print requirement, ink drying condition, load/unload arrangement, pad stroke speed, pad hardness, production setup, product quality and production control.



Oriel House, Block F, Sunbury Business Centre
 Brooklands Close, Sunbury on Thames, TW16 7DX
 TEL: 01784 460500 FAX: 01784 460505 EMAIL: info@tamppo.co.uk
www.tamppo.co.uk

