



WWW.LOCINOX.COM

CODE: GBMU4D16

① 180° Opening - Opening - Ouverture - Öffening

Grondaanslag verplicht - Butée obligatoire - Ground stop obligatory - Grundanschlag verpflichtit

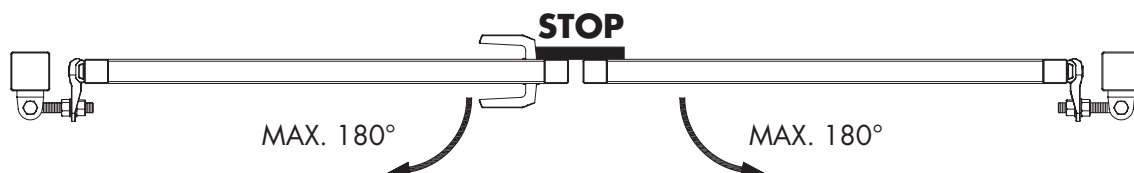

② Gewicht en afmetingen - Weight and dimensions

Poids et dimensions - Gewicht und Abmessungen

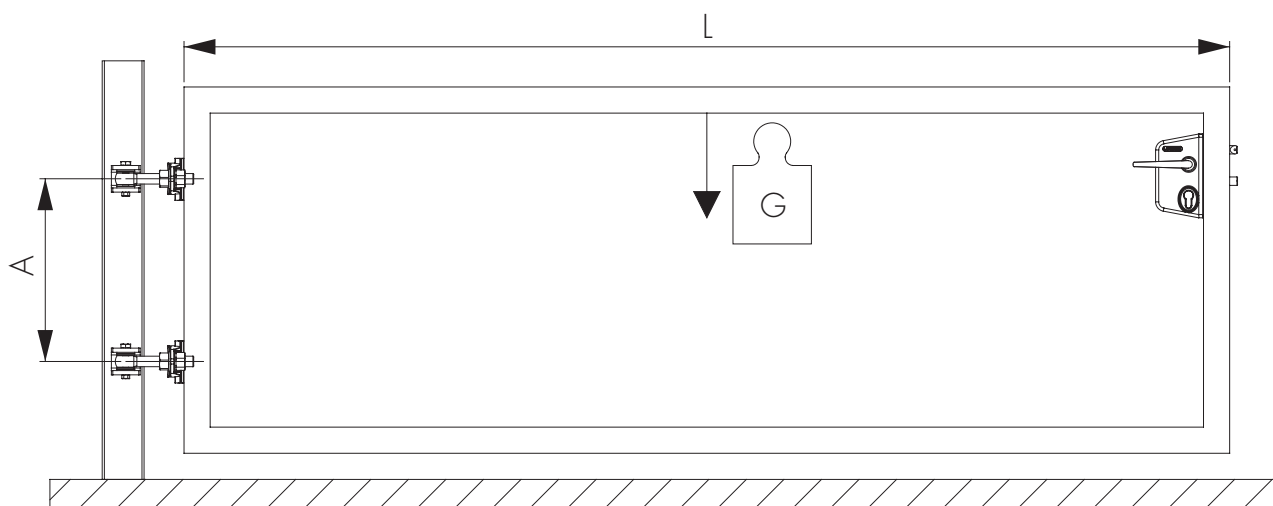

Max. trekkracht/ scharnier	Max. pull power/ hinge	Force de traction max./charnière	Max. Zugkraft/ Torband	10000 N
Veiligheidsfactor	Safety Factor	Facteur de sécurité	Sicherheitsfaktor	4

A	Min. afstand tussen de scharnieren in mm	Minimum distance between the hinges in mm	Entraxe minimum entre les charnières en mm	Min. Abstand zwischen den Torbändern in mm
L	Lengte van de poort in mm	Gate length in mm	Longueur du portail en mm	Torlänge in mm
G	Maximumgewicht van de poort in kilogram (kg)	Maximum gate weight in kilogram (kg)	Poids maximal du portail en kilogrammes (kg)	Maximumgewicht des Tores in Kilogramm (kg)

A								
500	1000	1500	2000	2500	3000	3500	4000	

—	1000	150	400	650	900	1150	1400	1650	1900
	1200	108	317	525	733	942	1150	1358	1567
	1500	67	233	400	567	733	900	1067	1233
	2000	25	150	275	400	525	650	775	900
	2500	0	100	200	300	400	500	600	700
	3000	0	67	150	233	317	400	483	567
	3500	0	43	114	186	257	329	400	471
G									

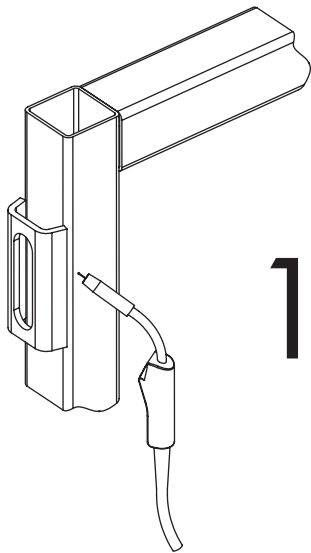

1

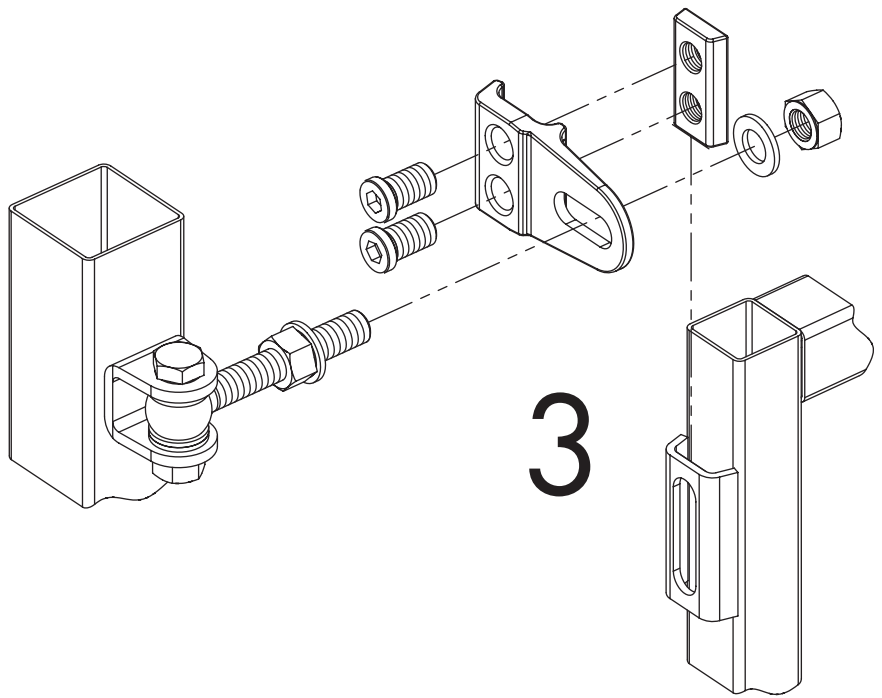

3

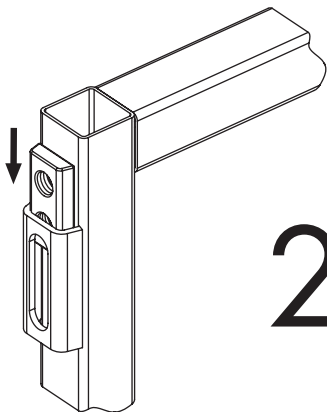

2

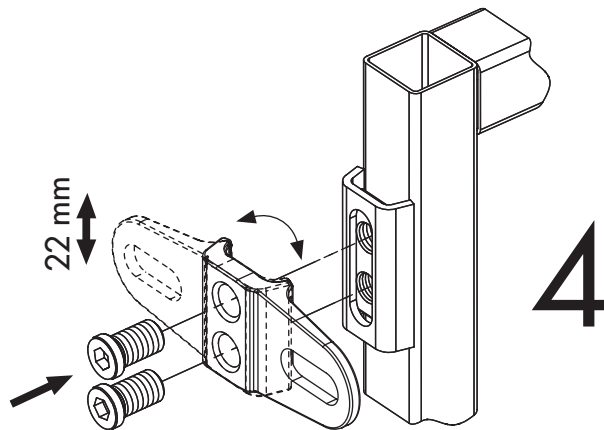

4

LOCINOX PRODUCTS - PRODUITS - PRODUKTEN - PRODUKTE

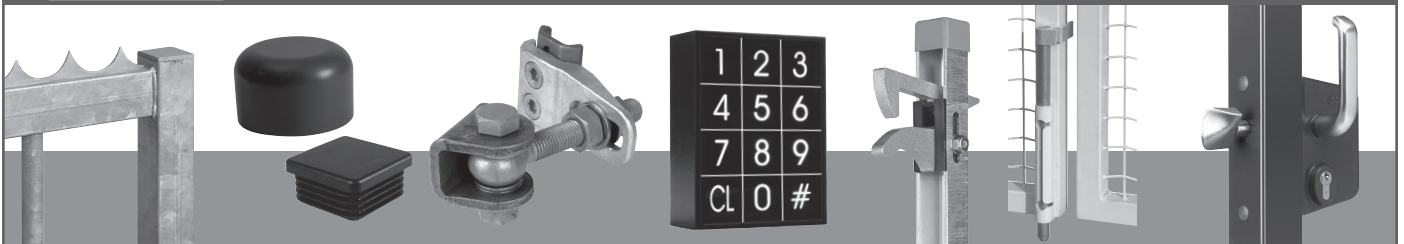

LOCINOX[®]
WWW.LOCINOX.COM

Doc. Nr.: MANU-000005



* M A N U - 0 0 0 0 0 5 *

Locinox nv • Mannebeekstraat 21 • B-8790 Waregem • Belgium - Europe
Tel. +32 (0)56 77 27 66 • Fax. +32 (0)56 77 69 26 • E-mail: locinox@locinox.com