

Posi-Glaze Fitting Instruction

1. Base Rail

The aluminium base rail should be put into place, and the holes marked onto the substrate for drilling, the aluminium base rail should then be levelled and plumbed up with the use of shims. Once the shoe is plumb and level the fixings should be tightened up to make the channel rigid the fixings should be tightened in accordance with the manufacturers instructions.

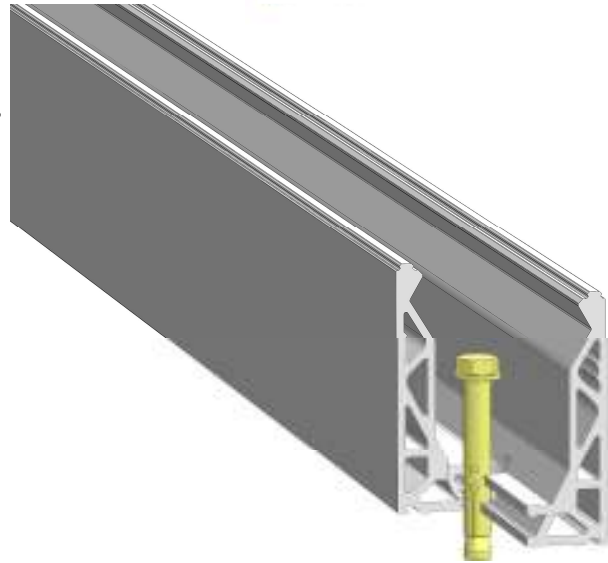

2. Glass slip clamp fitting

The glass slip clamp needs to be placed on the bottom of the glass. This requires lifting the glass off the floor sufficiently to squeeze these on or turning the glass upside down. The slip clamps require spacing according to the glass thickness these are as follows :-

19mm is 5 clamps per metre so number one should be in 100mm from the end of the glass and then 200mm there after

The 15mm, 17.5mm and 21.5mm laminate is 4 clamps per metre so number one should be in 125mm from the end of the glass and then 250mm there after

12mm is 3 clamps per metre so number one should be in 150mm from the end of the glass and then 350mm there after.

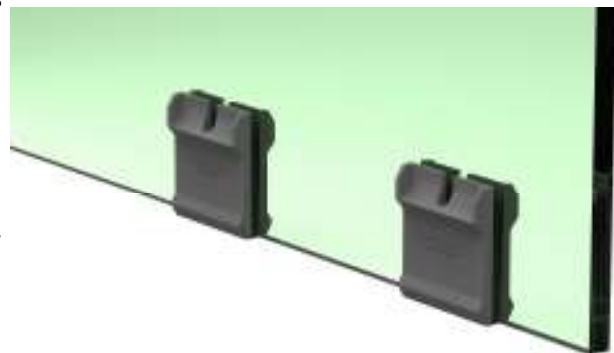

3. Glass Clamp Bar Fitting

Once the glass is fitted in to place you now need to press in the clamp bars into the top of each glass slip clamp. These need to be put in the right way for correct and proper fitment this is shown in the image right.

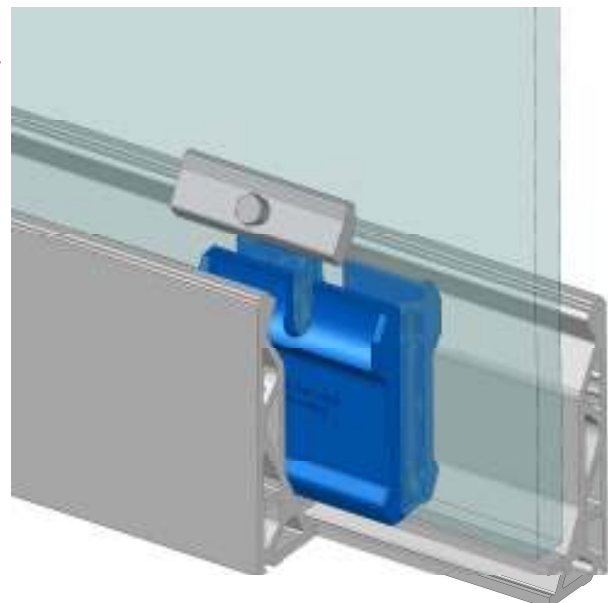

4. Getting glass plumb and tightening bolts

Once these are in you now need to place a spirit level on the glass to get the glass plumb. These bolts now need tightening into the channel equally to keep the same pressures on the glass. To achieve this firstly plumb and level each end of the glass and tighten. Then tighten the intermediate clamp bars. Once the bolts have pinched they now need a torque of: - ??NM to securely hold the glass in place.



5. Top Seal Strip

The gasket requires feeding into the smaller channels supplied. Once these are flush with each end the strip now needs to be clipped onto the top of the channel this can be done by pressing the whole thing on evenly or working from one end which is recommended. Do not stretch the gasket

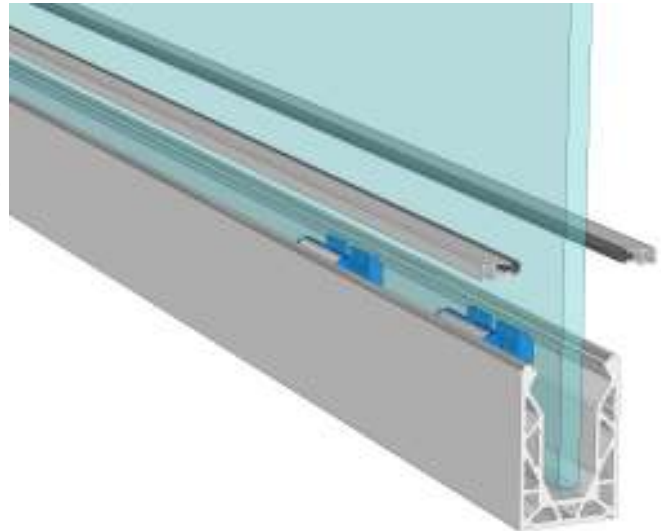

6. Cleaning

Once you are happy everything is in place and the job is complete you need to clean the glass and channel we recommend the use of any standard glass cleaner so long as it is not abrasive. We also recommend a soft sponge or cloth again to avoid any risk of scratching.

We have tried to make the system as simple and easy to install as possible, however should you not feel confident enough to fit this please contact a reputable glazier or builder.

Should any problems arise please don't hesitate to contact us through the following ways:-



Barrier Components Ltd

Unit 8 Dolphin Way Dolphin Point Purfleet Essex RM19 1NR
sales@barrier-components.co.uk www.barrier-components.co.uk
t: 01708 891 515 f: 01708 891 516