

# SIDE MOUNTING INSTRUCTIONS

1. Set a string line to enable threaded rods to be drilled and set into the wall to ensure that the top rods are in alignment (level).

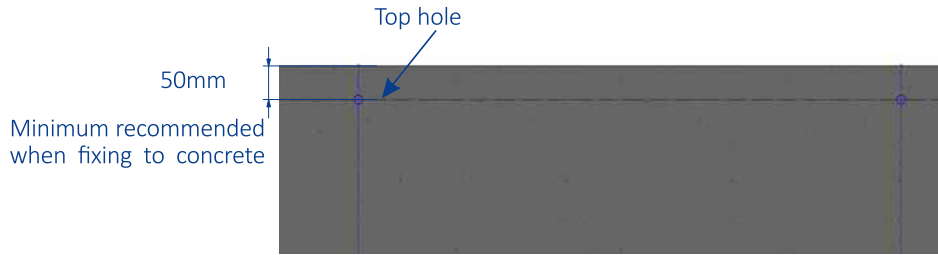

2. Work out the spacing required for top mounts and mark the top holes and using a level mark the bottom holes which are 75mm apart. The threaded rods should be chemset and protrude from the wall between 14mm and 18mm to ensure that the special nuts provide will fully engage.

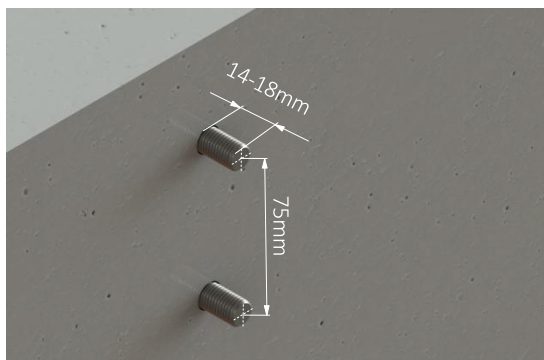

3. The bottom of the glass will be 86mm below the centre of the top threaded rod and when installed the distance from the wall to the glass should be 42mm.

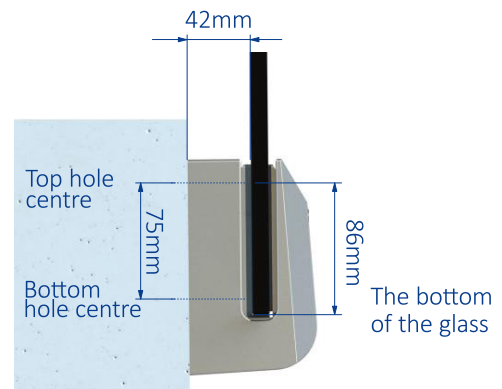

4. When the rods are cured, fit the glass mounts over the rods and using the nut supplied wind tighten by hand initially, or using a shortened Allen key provided tighten as far as possible, then using our special socket (to be ordered separately) tighten nut securely.

1) Fit the glass mounts over the rods

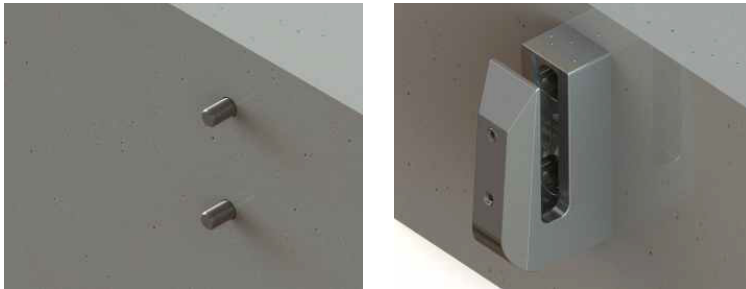

2) Tighten nut

Wind special nuts provided onto threads by hand initially. When hand tight use an Allen key (cut down) to wind the nuts on further until there is sufficient room to allow the special socket available from your supplier to fit inside the glass mount.

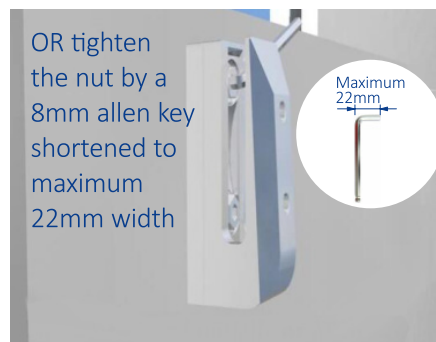

3) Tighten nut completely



5. Select the correct plastic for the glass thickness to be used. For more adjustment, use plastics for a thicker glass and use spare plastics to shim across.

1) Install the press plate & plastic



2) Set up glass



3) Tightening and adjustment

Tightening

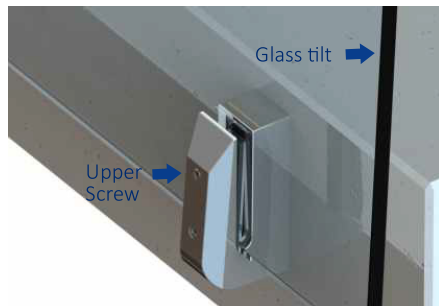
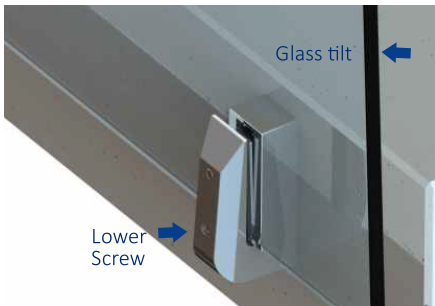

Adjustment

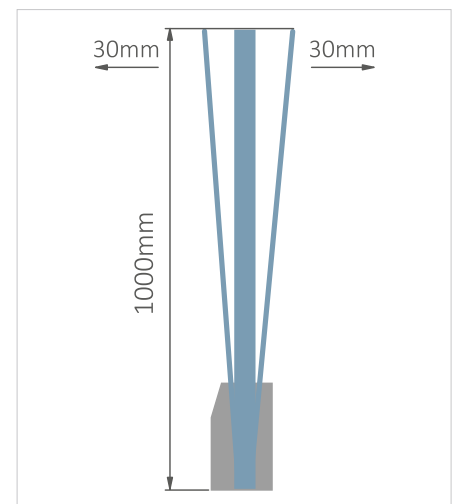

**Barrier Components Ltd**

Unit 8 Dolphin Way Dolphin Point Purfleet Essex RM19 1NR  
sales@barrier-components.co.uk www.barrier-components.co.uk  
t: 01708 891 515 f: 01708 891 516