

SAMSON 14A, 14B & 14P



Double Eccentric Butterfly Valves

FEATURES AND BENEFITS

Self-adjusting PTFE V-ring Packing

- Maintenance-free design
- Low friction promotes long service life

Large surface multiple bearing bushing improves rigidity of the shaft and reduces packing wear

Unique design mounts the fastening ring without screws

Large Sealing Surface Area

- The large sealing surface of the seat and disc seal ring guarantees a bi-directional tight shutoff, even at high pressures

Double eccentric disc with precise sealing surface

Seat Ring

- Spring loaded PTFE seat ring allows for a bubble tight shut off by maintaining elasticity, even after repeated compression.

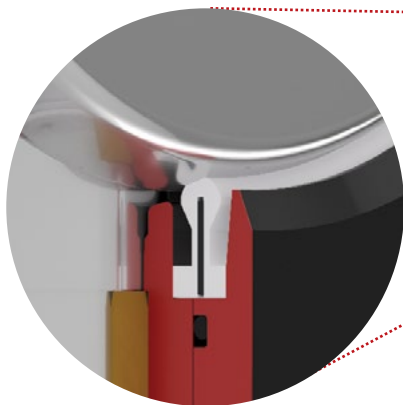

Actuator Mounting

- Flange according to ISO 5211
- Two flats to eliminate slippage

Disc Shaft

- Anti-blowout single piece design
- Disc is pinned to form a friction fit connection.

The extended body neck keeps the packing away from extreme temperatures, extending the packing lifespan.

A screwless flange design reduces leakage due to an uninterrupted sealing surface

Face-to-Face Dimension

- Standard length according to API 609
- Custom face-to-face lengths are possible due to the uniquely designed fastening ring

Bearing bushing protected with a high temperature corrosion resistant coating

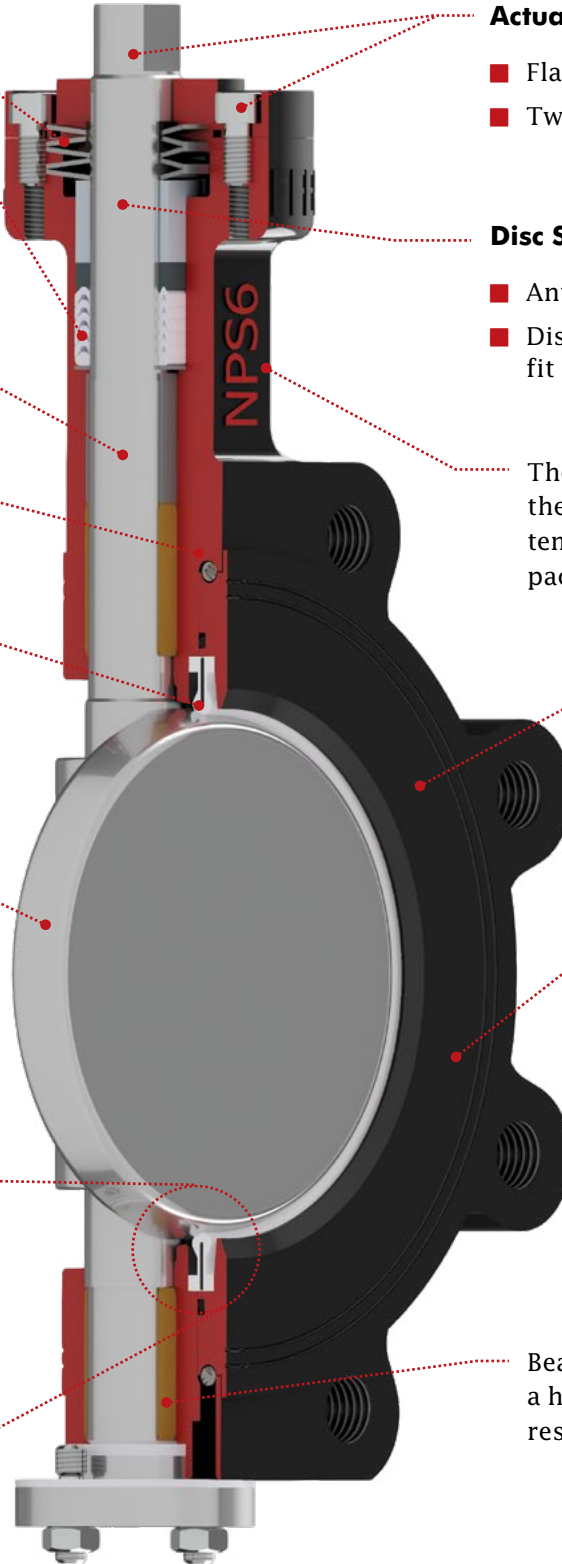

BUTTERFLY VALVES - EXPLAINED

CENTRIC BUTTERFLY DESIGN

- The first butterfly valve was designed in such a way that the body, shaft, and seat all shared the same axis. The disadvantage of this early design is that it creates significant friction between the disc and seat during the opening and closing operation.

DOUBLE ECCENTRIC BUTTERFLY DESIGN

- To allow for quick displacement of the disc from the body seals, the shaft is placed behind the centerline of the disc seat and body seat (1st offset).
- The shaft is also slightly offset from the centerline of the body (2nd offset). The combination of these two offsets minimizes friction during operation.

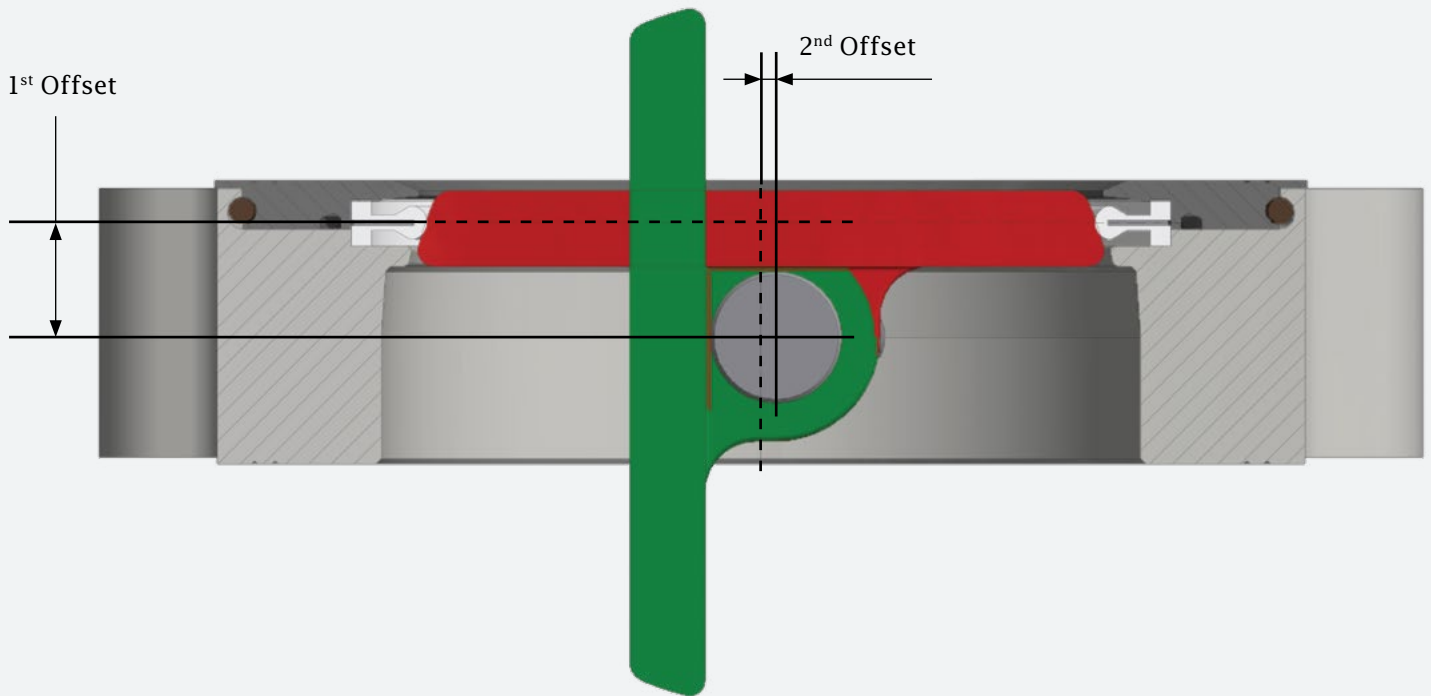

DESIGN BENEFITS OF A DOUBLE ECCENTRIC BUTTERFLY VALVE

- Reduced friction minimizes wear and extends service life
- Better controllability is achieved due to lower hysteresis
- Lower actuator torque requirement reduces size & cost
- Tight shut-off achievable over a longer service life

SPECIAL APPLICATIONS

Pressure Swing Adsorption (PSA)

Pressure swing adsorption is a method used to separate a gas from a gas mixture, as well as to dry or clean gases. The purity and quantity of the gas to be extracted strongly depends on the control valves used in this process.

CHALLENGES: The valves used in PSA applications must shut-off tightly, have short opening and closing times, and maintain a high level of reliability even after repeated cycling. SAMSON has developed the double-eccentric 14p butterfly control and shut-off valve to meet these challenging requirements.

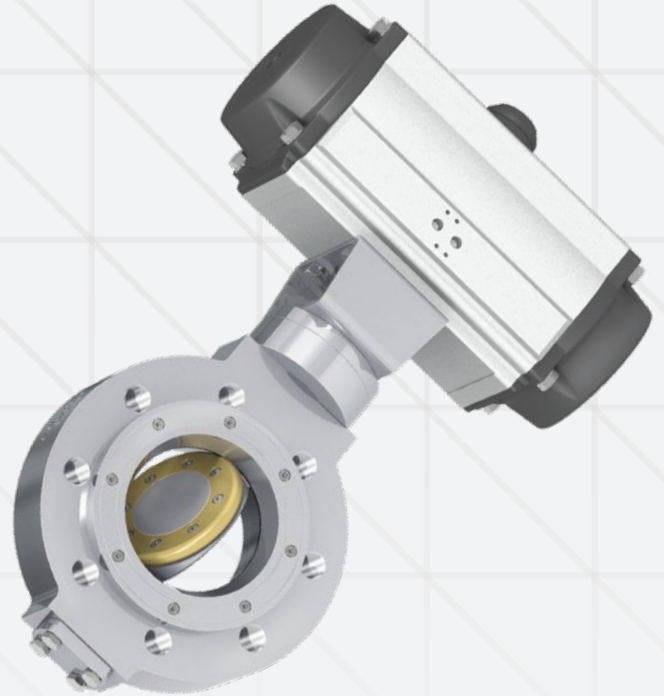
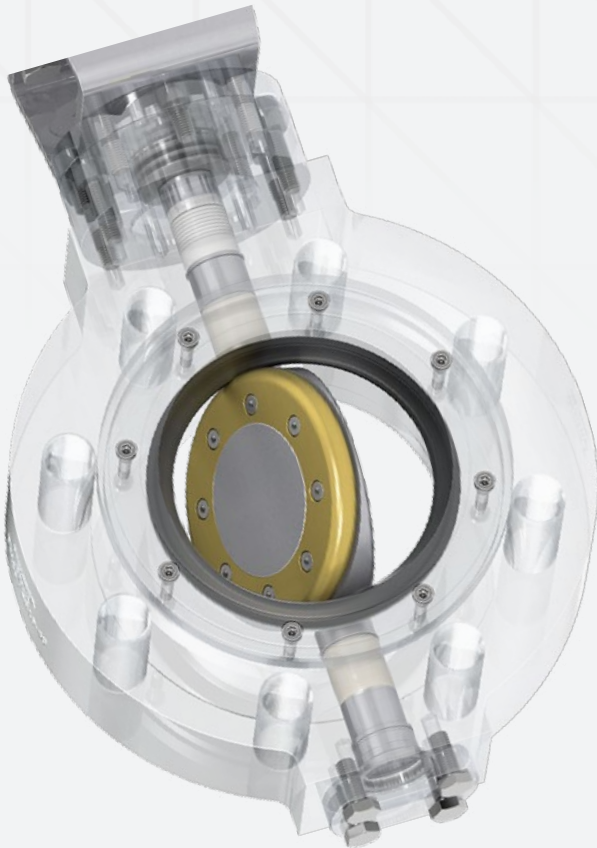

SOLUTION:

- A specially coated disc seal ring and specially made PTFE body seat achieve almost frictionless bubble-tight operation
- A combination of live loaded and V-shape chevron type packing together with an O-ring type primary seal increases the reliability of the valve against external leakage
- A double eccentric design with low friction & breakaway torque reduces wear in the valve and actuator

GENERAL APPLICATIONS:

- Oxygen production in steel and chemical plants
- Hydrogen recovery from coking and conversion gases
- Gas separation in molecular sieve units

Cryogenic and High Temperatures



CHALLENGES:

- Extreme temperatures, typically down to -320°F (-196°C) and above 752°F (400°C), can push the material properties to their limits and pose many additional leakage and material expansion challenges.

SOLUTION:

- The strict machining tolerances and high-quality materials used in the 14 series butterfly valves allow the valve to function at these extreme temperatures.
- The standard 14b with an RPTFE seat can guarantee maximum sealing under low temperatures conditions down to -320 °F (-196 °C).
- The BR14C (an upgraded modification of the BR14b valve) with specially selected alloy materials can be used for temperature up to 1202 °F (650 °C)

Pulp, Paper, and other Sticky Service

CHALLENGES:

- A buildup of medium in the valve seating area prevents the valve from closing, thereby leading to leakage past the seat
- Additional buildup of medium in the bushing areas can also cause the valve stem to stick

SOLUTION:

- The valve trim and body internals are coated with a special non-stick paint, permitting a continuous flow of media through the valve
- The inner packing/outer bearing and primary O-ring seal protect the valve stem and bushing from sticking

Diffusion Silencer / Noise Absorber

CHALLENGES:

- High noise emissions generated through large pressure drops in gases
- Heavy vibration of valve, pipeline, and other components caused by excessive noise

SOLUTION:

- The specially designed diffusion and noise absorbers create multiple small pressure drops, reducing the medium velocity. This in turn prevents excessive noise and vibration in the valve.

TECHNICAL DETAILS

Valve Size	NPS 2 to 32
Pressure Rating	ANSI Class 150 and 300
End Connections	Wafer and Lugged
Materials	<ul style="list-style-type: none">■ Carbon Steel (A216 WCC, A352 LC3)■ Stainless Steel (A351 CF8M)
Temperature Range	-320 to +1022°F (-196 to 550°C)
Internal Leakage Rate (According to ANSI/FCI 70-2)	<ul style="list-style-type: none">■ Class IV: Metal Seat■ Class VI: Soft Seat
Face-to-Face Dimensions	API 609

SAMSON's technology has proven its value worldwide in a variety of industries. We are trusted in many of the world's most challenging applications to achieve precise control with a high level of safety and reliability.

The SAMSON product portfolio offers engineered solutions from a single source. With our extensive range of valves, actuators, and accessories we have the right products to suit your requirements.

Our linear and rotary control valves are carefully selected and sized to ensure reliable operation with reduced maintenance requirements. The latest in positioner technology offers precise control, seamless

integration into process control systems, and advanced diagnostics to allow for predictive maintenance.

The modular design of our products allows customers to benefit from a tailor-made solution at an affordable cost. Furthermore, the interchangeability of spare parts between different valve models and sizes contributes to keeping inventory costs low.

Continuous investment in research and development allows us to stay at the cutting edge of technology. With over 100 years of experience and expertise, you can count on SAMSON to provide a robust solution for your application.

SAMSON
AIR TORQUE · CERA SYSTEM · KTELEKTRONIK · LEUSCH
PFEIFFER · RINGO · SAMSOMATIC · SED · STARLINE · VETEC

4111 Cedar Blvd.
Baytown, TX 77523 USA
Phone: 877-762-7668

1-105 Riviera Drive
Markham, ON L3R 5J7 Canada
Phone: 800-772-6766



www.samsoncontrols.com



contactus@samsongroupna.com