

SAMSON

SAMSON

GLOBE CONTROL VALVE TYPE 3291

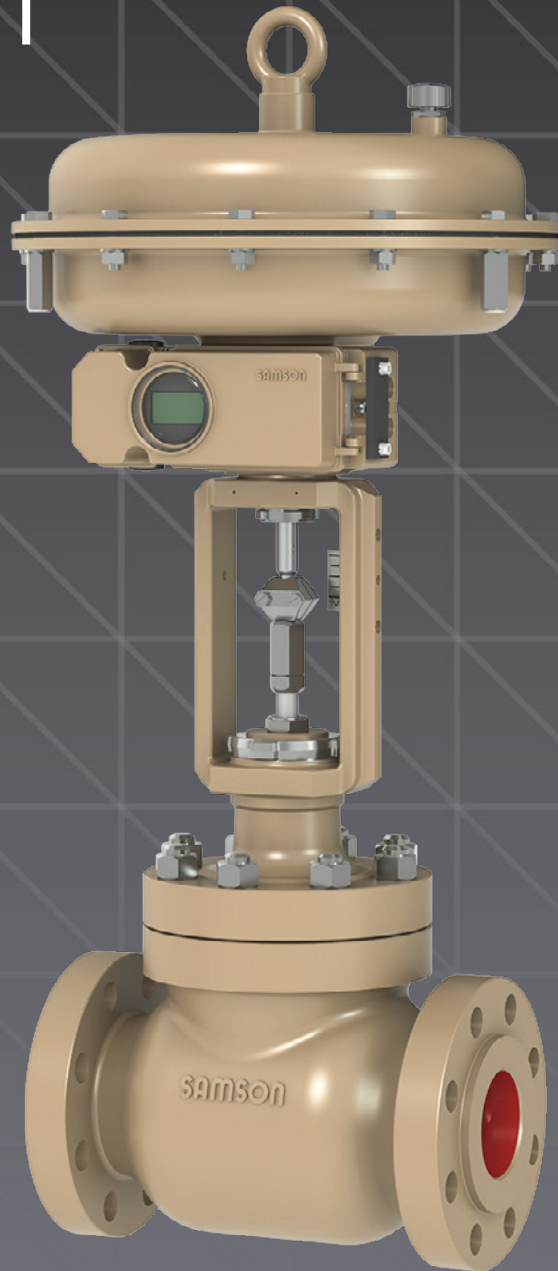

FEATURES AND BENEFITS

Integrated Accessory Attachment

- Eliminates external tubing
- Protects mechanical feedback linkage
- Entire actuator top works can be rotated 360° without disassembly

SAMSON Smart Devices

- Easy push-button positioner initialization
- Intrinsically safe & explosion proof options available
- EXPERTPlus Diagnostics

Self-adjusting PTFE V-ring Packing

- Maintenance-free design
- Low friction
- Roller burnished stem reduces friction, external leakage, and maximizes packing life beyond what basic polishing can offer from competitors.

Patented Multi-layered Bellows Technology

- Double wall design
- Small valve travel results in a long bellows life
- Modular design allows for the addition or removal of bellows in the field

Clamped Seat Design

- No special tooling required
- Robust seat retention
- Flute guiding reduces chances of erosion damage if debris exists

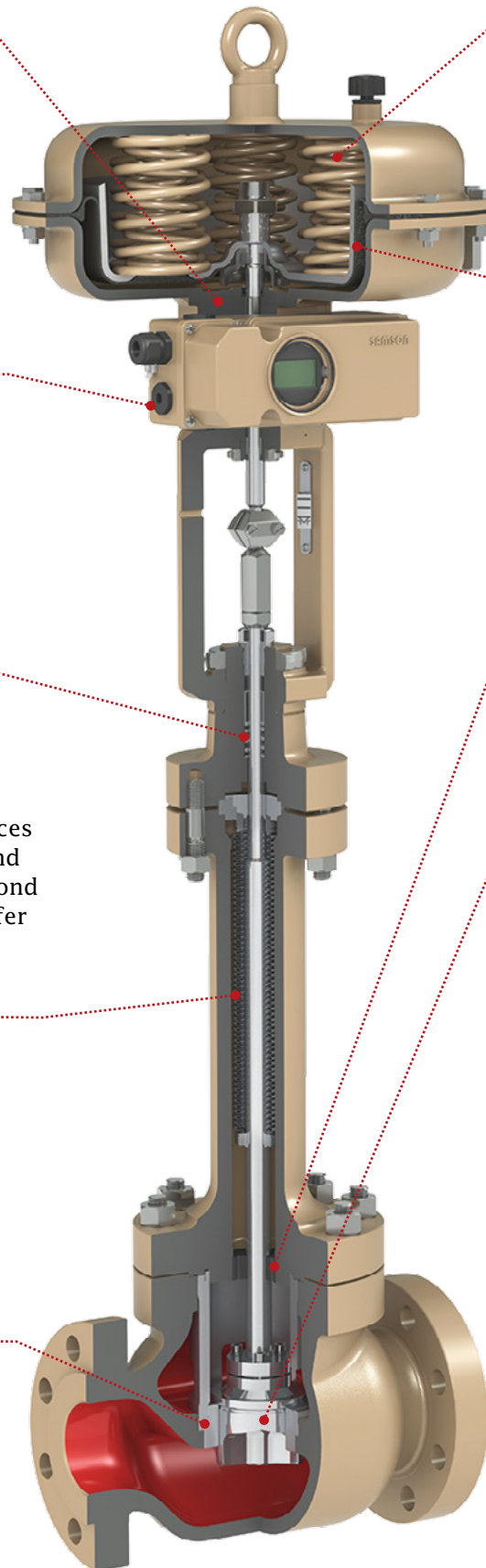

Field Reversible Nested Multi-Spring Actuator

- Reduced height and weight
- Easily convert between fail actions in the field with minimal effort

Rolling Diaphragm

- Greatly reduces diaphragm wear compared to stretching diaphragm design used by competitors.
- Diaphragm design results in very small external air loss

Low Lying Guide Bushing

- Ensures precise plug alignment for our stem guided trim

Multiple Plug Designs

- Parabolic - Cost effective & debris friendly
- V-Port - Reduced vibration & debris friendly
- Perforated - Vibration reduction and flow dispersion

Various Noise Attenuation Options

- Flow Divider I and II (Gases/Vapors)
- Anti-Cavitation Trims (Liquids)
- Optional downstream orifice plates

INTERNAL STRENGTH

Trim For Every Application

Obstacles hindering accurate process control can be numerous. The 3291 comes equipped with a wide range of available trim options to overcome difficult to control applications.

- Parabolic Plug
- V-Port Guided Plug
- Perforated Plug
- Multi-Stage Trim
- Noise Attenuation Trim



Noise Reduction

When not getting noticed is a good thing

A flow divider is an optional internal device used with gases and vapors to help reduce the sound pressure level (SPL) of a valve. By creating an additional stage of pressure reduction inside the valve, it breaks a single large flow stream into multiple smaller flow streams, resulting in reduced noise emissions.

Two versions of flow dividers are available, based on the amount of noise reduction required. Depending on flow conditions, noise reductions of up to 20 dB(A) can be achieved.



Packing

The 1st line of defense

- Standard spring-loaded V-ring packing
 - Maintenance free & self adjusting
- Pure graphite or pure PTFE options
- Adjustable packing options
- Emission standards
 - ANSI / FCI 91-1 (EPA Method 21)
 - ISO 15848
 - TA-Luft / VDI 2440
 - Shell SPE 77/312



Bellows Seal

Nothing left to chance

Many plants rely on toxic or highly reactive compounds for their processes. These compounds can present an inherent health and/or safety hazard and must be contained.

SAMSON's bellows seal technology is the leader in design and performance.

The bellows seal helps ensure fugitive emissions are contained and leaks to the atmosphere are minimized down to near zero levels.

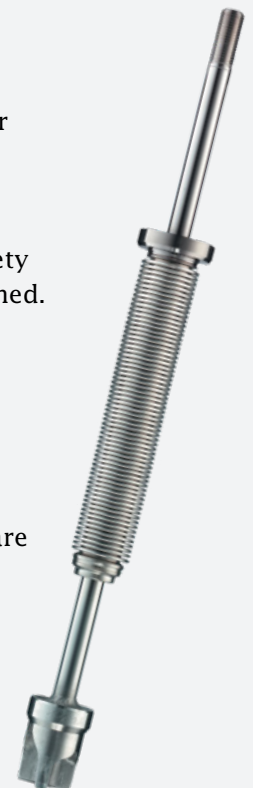

SPECIAL APPLICATIONS

Steam Service

Steam is commonly used in many plants and processes, it can however be very hard on industrial equipment. The ability to prolong the service life of valve internals in these harsh conditions is crucial to reducing costs and increasing plant productivity.

At SAMSON, we use various hardening techniques to combat these severe service applications. By making use of metal hardening, tungsten carbide, and ceramics, we are able to provide a variety of solutions to resist wear from these processes. The result is an increased valve life and a reduced total cost of ownership.

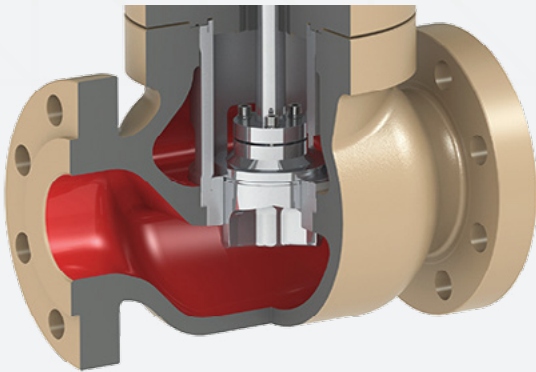

NACE Service

When oil and gas are first recovered, hydrogen sulfide (H₂S) may be present, which can cause hydrogen induced cracking in certain metals.

The 3291 NACE version only uses materials in compliance with NACE MR0175 / ISO 15156 specifications certified for use with H₂S.



Toxic and Corrosive Processes

SAMSON valves are trusted in some of the world's most toxic and hazardous applications. From Phosgene to Hydrofluoric Acid, the 3291 can be customized to overcome the challenges of corrosive applications.



No matter the process requirements, the 3291 valve can be built to your specifications.

Anti-Cavitation

Cavitation occurs within valves that have a sufficient initial pressure drop and subsequent pressure recovery. This effect can cause excess noise, accelerated wear, or substantial damage to the valve body and trim.

The 3291 valve can be fitted with a variety of options to help either resist the forces and damage of cavitation with hardened trims, or to design around preventing the formation of cavitation with multi-stage trim designs.



SAMSON – OUR EXPERTISE

Engineered Solutions From a Single Source

Combined with valve accessories, control valves serve as engineered solutions for many process control applications. SAMSON has been developing and manufacturing high-quality valves, actuators and valve accessories for over 100 years. Our experience and expertise allows us to continuously develop our products to provide a complete solution for your application.

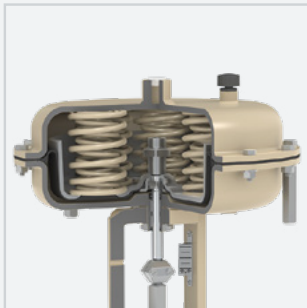

Actuators

SAMSON's multi-spring actuator provides a lightweight and compact design; the unique rolling diaphragm offers an exceptionally long life even through high cycle counts. Our actuators can be built, designed, painted, and coated to be suitable for all types of environmental conditions, from general service to highly corrosive environments.



Positioners

Our positioners are designed to enhance the performance, reliability, and serviceability of any valve in process control applications. The SAMSON product portfolio covers the full range of positioner types. From the pneumatic and analog electro-pneumatic positioners that have been trusted for decades, to fully digital devices utilizing automatic calibration, central communications, and the most advanced monitoring and diagnostics.



Limit Switches

The limit switch product portfolio offers solutions for applications where indication is required when the valve travel exceeds or falls below a pre-defined limit. Available options include inductive, electric, pneumatic, or software contacts and can contain up to three switches depending on the device. Limit switches can be used for switching control signals, providing audible/visual notification, or for connection to central control or alarm systems.



Solenoid Valves

SAMSON solenoid valves offer a high level of reliability for pneumatic switching applications with the added benefit of minimal power consumption. Commonly used for the opening and closing of valves in basic process control and safety systems (SIS), they are available in a wide variety of configurations including 3/2, 5/2, 5/3, or 6/2-way functions to suit any application.

TECHNICAL DETAILS

Valve Size	NPS ½ to 8
Pressure Rating	ANSI Class 150 to 900
End Connections	<ul style="list-style-type: none"> ■ Flanged: All ANSI versions ■ Welding Ends: According to ANSI B16.25
Materials	<ul style="list-style-type: none"> ■ Carbon Steel (A216 WCC, A352 LCC, & A217 WC6) ■ Stainless Steel (A351 CF8M & A351 CF3M) ■ Special materials (Monel, Hastelloy C, Duplex, etc.)
Temperature Range	-325 to +842°F (-196 to 450°C)
Internal Leakage Rate	Class IV, V, or VI according to ANSI/FCI 70-2 and IEC 60534-4
Extensions	Standard / Insulating / Bellows Seal
Packing	Spring-Loaded Low Emission V-ring Packing

SAMSON's technology has proven its value worldwide in a variety of industries. We are trusted in many of the world's most challenging applications to achieve precise control with a high level of safety and reliability.

The SAMSON product portfolio offers engineered solutions from a single source. With our extensive range of valves, actuators, and accessories we have the right products to suit your requirements. Our linear and rotary control valves are carefully selected and sized to ensure reliable operation with reduced maintenance requirements. The latest in positioner technology offers precise control, seamless integration into process control systems, and advanced diagnostics to allow for predictive maintenance.

The modular design of our products allows customers to benefit from a tailor-made solution at an affordable cost. Furthermore, the interchangeability of spare parts between different valve models and sizes contributes to keeping inventory costs low.

Continuous investment in research and development allows us to stay at the cutting edge of technology. With over 100 years of experience and expertise, you can count on SAMSON to provide a robust solution for your application.

SAMSON

AIR TORQUE · CERA SYSTEM · KFELEKTRONIK · LEUSCH
PEIFFER · RINGO · SAMSOMATIC · SED · STARLINE · VETEC

4111 Cedar Blvd.
Baytown, TX 77523 USA
Phone: 877-762-7668

1-105 Riviera Drive
Markham, ON L3R 5J7 Canada
Phone: 800-772-6766



www.samsoncontrols.com



contactus@samsongroupna.com