

SAMSON

SAMSON

GLOBE CONTROL VALVE TYPE 3522

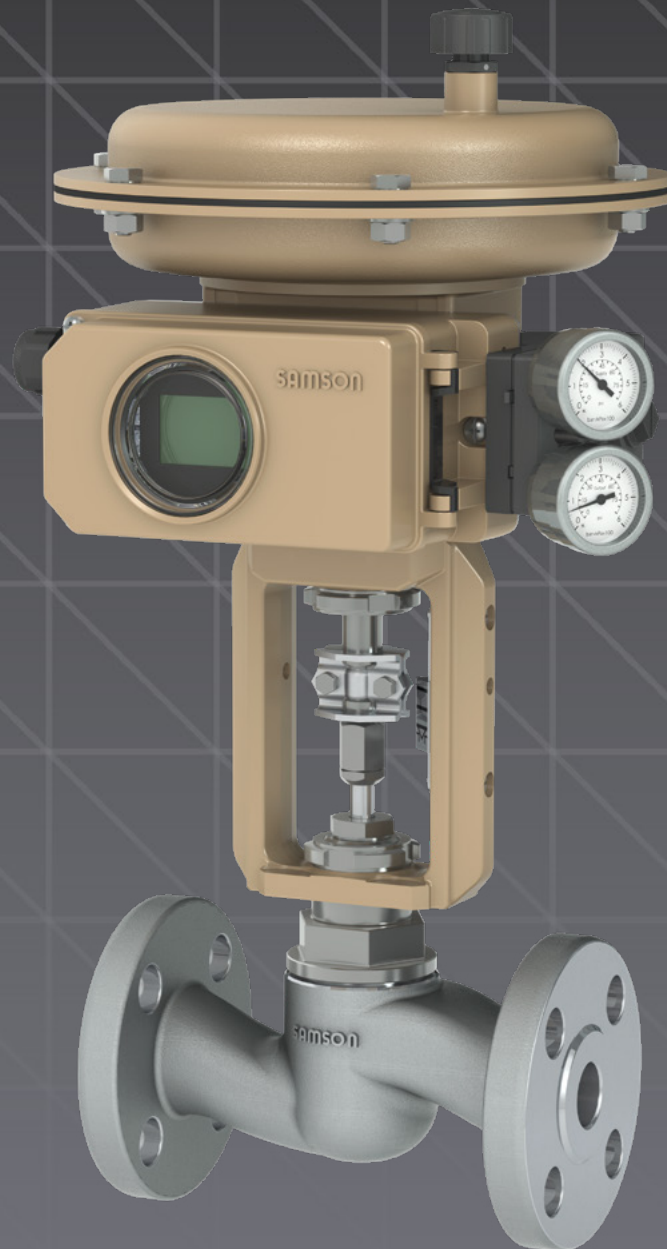

FEATURES AND BENEFITS

Field Reversible Nested Multi-Spring Actuator

- Reduced height and weight
- Easily convert between fail actions in the field with minimal effort

Integrated Accessory Attachment

- Eliminates external tubing
- Protects mechanical feedback linkage
- Entire actuator top works can be rotated 360° without disassembly

Self-adjusting PTFE V-ring Packing

- Maintenance-free design
- Low friction
- Roller burnished stem reduces friction, external leakage, and maximizes packing life beyond what basic polishing can offer from competitors.

Threaded Bonnet

- Prevents uneven bonnet tightening

Threaded Seat Design

- No cage, gaskets, or seals required
- Fewer spare parts required for maintenance
- Easy removal even after many years of service

Rolling Diaphragm

- Greatly reduces diaphragm wear compared to stretching diaphragm design used by competitors.
- Diaphragm design results in very small external air loss

SAMSON Smart Devices

- Easy push-button positioner initialization
- Intrinsically safe & explosion proof options available
- EXPERTPlus Diagnostics

Low Lying Guide Bushing

- Ensures precise plug alignment for our stem guided trim

Multiple Plug Designs

- Parabolic - Cost effective & debris friendly
- V-Port - Reduced vibration & debris friendly

Hex Ends (Threaded version)

- Allows for easy wrench placement and installation

Valve Body Connections

- Raised Face Flange
- Female NPT

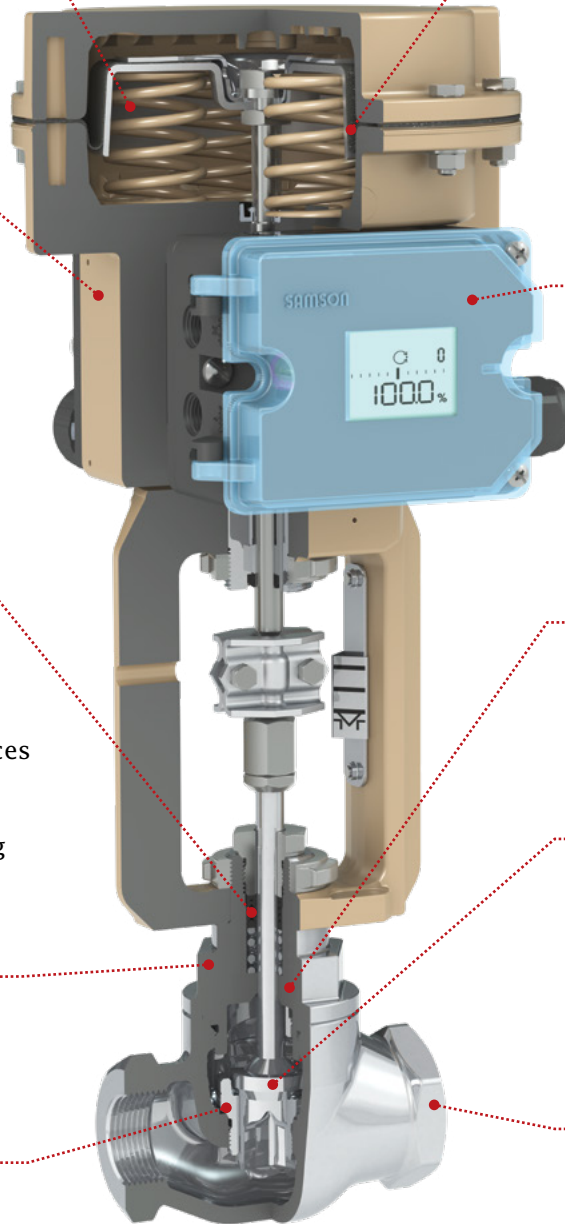

SAMSON – OUR EXPERTISE

Engineered Solutions From a Single Source

Combined with valve accessories, control valves serve as engineered solutions for many process control applications. SAMSON has been developing and manufacturing high-quality valves, actuators and valve accessories for over 100 years. Our experience and expertise allows us to continuously develop our products to provide a complete solution for your application.



Actuators

SAMSON's multi-spring actuator provides a lightweight and compact design; the unique rolling diaphragm offers an exceptionally long life even through high cycle counts. Our actuators can be built, designed, painted, and coated to be suitable for all types of environmental conditions, from general service to highly corrosive environments.



Positioners

Our positioners are designed to enhance the performance, reliability, and serviceability of any valve in process control applications. The SAMSON product portfolio covers the full range of positioner types. From the pneumatic and analog electro-pneumatic positioners that have been trusted for decades, to fully digital devices utilizing automatic calibration, central communications, and the most advanced monitoring and diagnostics.



Limit Switches

The limit switch product portfolio offers solutions for applications where indication is required when the valve travel exceeds or falls below a pre-defined limit. Available options include inductive, electric, pneumatic, or software contacts and can contain up to three switches depending on the device. Limit switches can be used for switching control signals, providing audible/visual notification, or for connection to central control or alarm systems.



Solenoid Valves

SAMSON solenoid valves offer a high level of reliability for pneumatic switching applications with the added benefit of minimal power consumption. Commonly used for the opening and closing of valves in basic process control and safety systems (SIS), they are available in a wide variety of configurations including 3/2, 5/2, 5/3, or 6/2-way functions to suit any application.

TECHNICAL DETAILS

Valve Size	NPS ½ to 2
Pressure Rating	ANSI Class 150 to 300
End Connections	<ul style="list-style-type: none">■ RF Flanged■ Female NPT
Materials	<ul style="list-style-type: none">■ Stainless Steel (A351 CF8M)■ Aluminum Bronze (B148 C95200)
Temperature Range	14 to 430°F (-10 to +220°C)
Internal Leakage Rate	Class IV, V, or VI according to ANSI/FCI 70-2 and IEC 60534-4
Packing	Spring-Loaded Low Emission V-ring Packing

SAMSON's technology has proven its value worldwide in a variety of industries. We are trusted in many of the world's most challenging applications to achieve precise control with a high level of safety and reliability.

The SAMSON product portfolio offers engineered solutions from a single source. With our extensive range of valves, actuators, and accessories we have the right products to suit your requirements. Our linear and rotary control valves are carefully selected and sized to ensure reliable operation with reduced maintenance requirements. The latest in positioner technology offers precise control, seamless integration into process control systems, and advanced diagnostics to allow for predictive maintenance.

The modular design of our products allows customers to benefit from a tailor-made solution at an affordable cost. Furthermore, the interchangeability of spare parts between different valve models and sizes contributes to keeping inventory costs low.

Continuous investment in research and development allows us to stay at the cutting edge of technology. With over 100 years of experience and expertise, you can count on SAMSON to provide a robust solution for your application.

SAMSON
AIR TORQUE · CERA SYSTEM · KTELEKTRONIK · LEUSCH
PFEIFFER · RINGO · SAMSOMATIC · SED · STARLINE · VETEC

4111 Cedar Blvd.
Baytown, TX 77523 USA
Phone: 877-762-7668

1-105 Riviera Drive
Markham, ON L3R 5J7 Canada
Phone: 800-772-6766



www.samsoncontrols.com



contactus@samsongroupna.com