

SAMSON

SAMSON



© Caloric Anlagenbau GmbH

Pressure Swing Adsorption

Reliable control at all stages in the process
PSA valves by SAMSON and SAMSON PFEIFFER

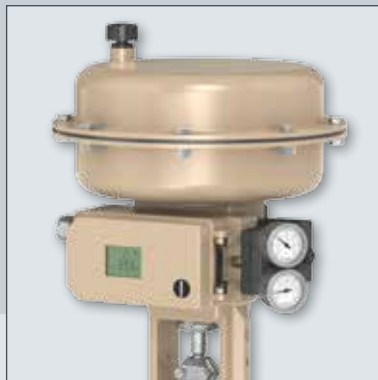

Competence in valve engineering

Founded in 1907, SAMSON has since become a worldwide leader in the manufacture of expertly engineered control valves.

SAMSON has over 50 subsidiaries, amongst them noted manufacturers of special valves, such as AIR TORQUE, CERA SYSTEM, LEUSCH, PFEIFFER, RINGO VÁLVULAS, SAMSOMATIC, STARLINE, and VETEC.

With our subsidiaries, we are represented in over 80 countries to assist our customers on all continents. SAMSON provides you with valve engineering and customer service from a single source:

- We support you in planning new installations or overhauling and expanding existing plants.
- We assist you in selecting and configuring the right equipment to suit your control requirements.
- We are close at hand to support your life cycle management, from installation and start-up to maintenance and service.



PSA valves by SAMSON and SAMSON PFEIFFER

- Reliability even at extremely high number of cycles
- Long service life
- Proven in use
- Product purity throughout the entire process
- Fugitive emission requirements verified in tests before product launch
- Ruggedness despite high mechanical load (frequent load changes)
- Easy maintenance
- Flexible upgrading through proven modular design
- Bi-directional flow (valve and flow divider)

Comprehensive service

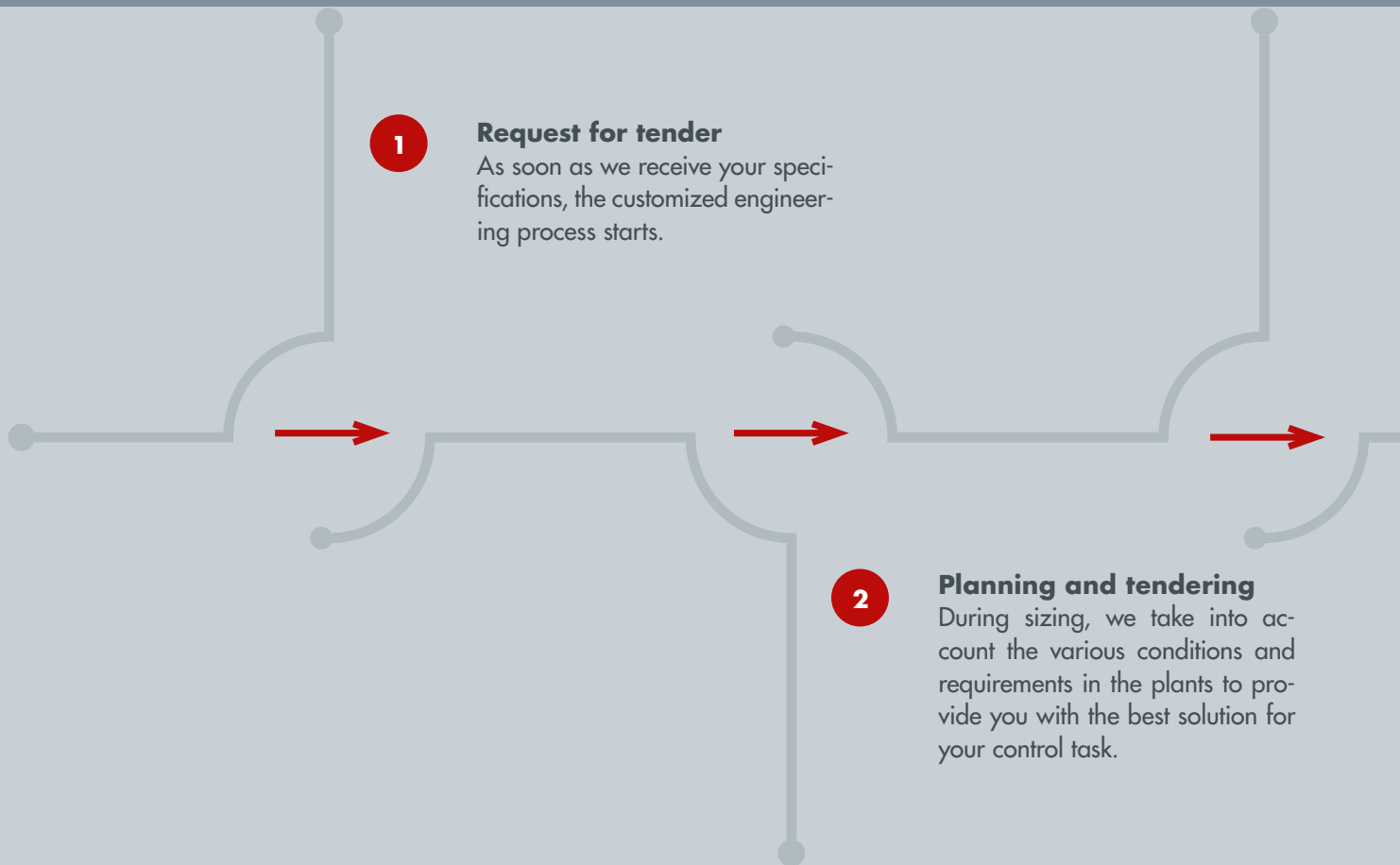



3 Production and quality control
After tendering is completed, production of the components starts, accompanied by continuous quality control.

5 After-sales service
Our after-sales service staff can support you in many ways: troubleshooting in the plant, spare parts management, servicing, re-engineering, or plant optimization.

4 Mounting and start-up
Our after-sales service staff applies their extensive specialized know-how on plants and devices to assist you with mounting and start-up. The tightly meshed global service network guarantees high availability and short response times.

PRESSURE SWING ADSORPTION

Gas separation and purification

Pressure swing adsorption is a process that separates single gases from a gas mixture. It is mainly used in chemical and petrochemical processes as well as the steel industry, for example to recover hydrogen (H_2) from coking or conversion gases, or to separate oxygen (O_2) and nitrogen (N_2) from air.

The adsorption process is based on gas molecules binding to an adsorbent material. The adsorbent bed is specially selected depending on the gas to be adsorbed. Ideally, only the gas to be separated is adsorbed, while all other gases in the mixture pass through the adsorbent bed. Frequently, adsorbents containing carbon (e.g. activated carbon or carbon molecular sieves) and oxide adsorbents (e.g. zeolite) are used. The purity of the adsorbed gas not only depends on the adsorbent used. The temperature and pressure during the process are important as well. As a result, the control valves used also contribute considerably to the quality of the end product.

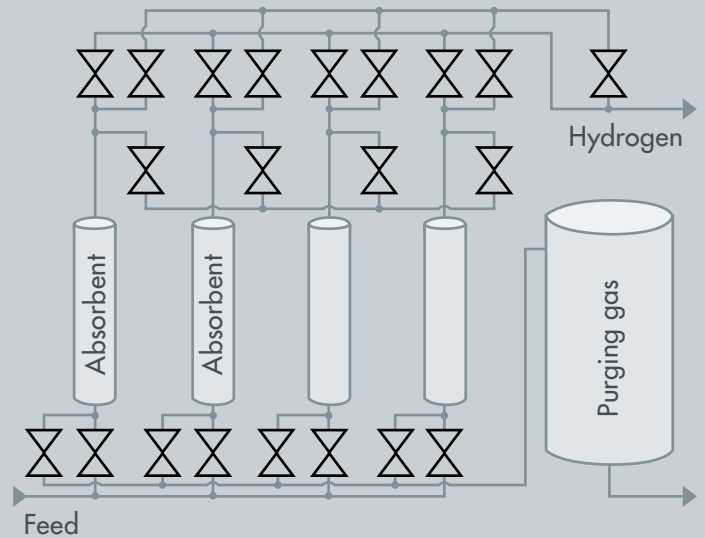



The pressure swing adsorption process is divided into four stages that occur in cycles:

1. Adsorption: adsorption takes place at high pressure (up to 40 bar). The feed gas is fed through an adsorbent bed. The adsorbent binds the easily absorbable gas molecules, while gas molecules that are not readily absorbable or not absorbable at all pass through the bed. The adsorbent bed continues to absorb gas molecules until it reaches its full capacity.

2. Depressurization: depressurization is the first regeneration (desorption) step of the full adsorbent bed. As the pressure drops, the gas molecules in the adsorbent bed are released and the target gas is discharged from the adsorber vessel.

3. Purging: the adsorbent bed is purged with the target gas to fully regenerate it.

4. Repressurization: the adsorber is pressurized using a feed gas mixture or the target gas until the process conditions for adsorption have been restored.

Usually, four to five adsorption vessels are combined so that the PSA process can run continuously. While adsorption occurs in one vessel, the regeneration process and repressurization take place in the other vessels.

Control and isolation of gas flows

SAMSON linear valves

Type 3241 PSA and Type 3251 PSA

- Valve size DN 15 to 150/NPS ½ to 6
- Pressure rating PN 10 to 63/Class 150 to 600
- Permissible temperature range
-10 to +220 °C/-20 to +430 °F
- Leakage class VI according to IEC 60534 or ANSI/FCI 70-2
- Flanged end connections
- Special versions of proven Type 3241 and Type 3251 Globe Valves
- Market launch in 1989



SAMSON PFEIFFER rotary valve

Type 14p PSA

- Double-eccentric version
- Valve size DN 80 to 400/NPS 3 to 16
- Pressure rating PN 10 to 40/Class 150 to 300
- Permissible temperature range
-20 to +180 °C/-4 to +356 °F
- Leakage rate A according to DIN 12266 and leakage class VI according to IEC 60534 or ANSI/FCI 70-2
- Lug-type or wafer-type body
- New addition to the SAMSON product portfolio after extensive testing before the product launch

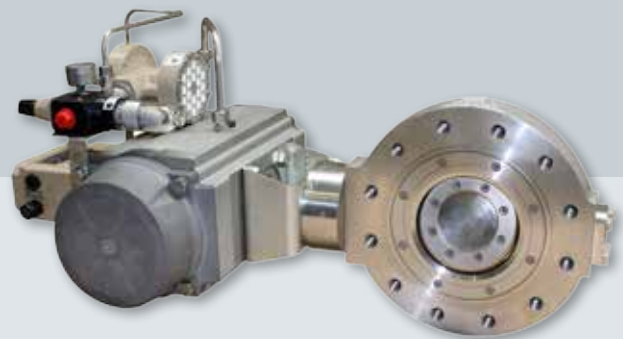

Testing before the launch of the SAMSON PFEIFFER Type 14p PSA Butterfly Valve

As part of an endurance test of the bi-directional high-performance butterfly valve for PSA applications, the seat leakage and external leakage (fugitive emissions) were tested in cycles with up to 1,000,000 load cycles.

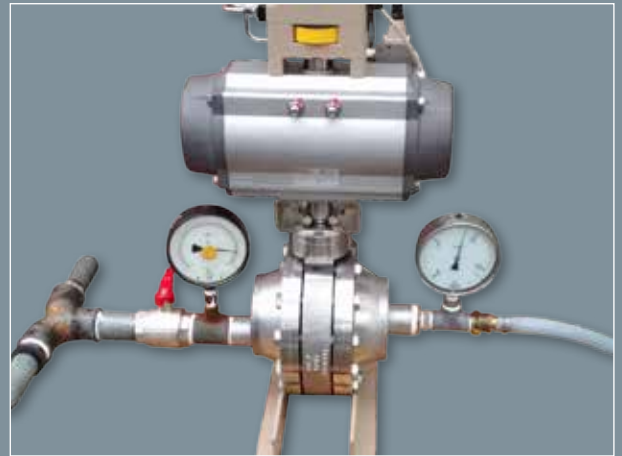

The test was performed on the following specimen:

- ✓ Valve size NPS 6, pressure rating Class 300
- ✓ Body and disk: A351 CF8M
- ✓ Shaft: AISI 630
- ✓ Elastomer seal (PSA version)
- ✓ Seat ring on disk: A479 316 Ti/HSB14
- ✓ Shaft seal: PTFE V-ring packing loaded by disk springs with an upstream primary seal
- ✓ TA Luft (fugitive emission) certification
- ✓ Actuator: SAMSON PFEIFFER Type 31a SRP 900

During the cycle, 10 bar(a) air pressure were applied to the inlet of the valve. The outlet was exposed to the atmospheric pressure of $p_2 = 1$ bar(a).

Seat leakage results

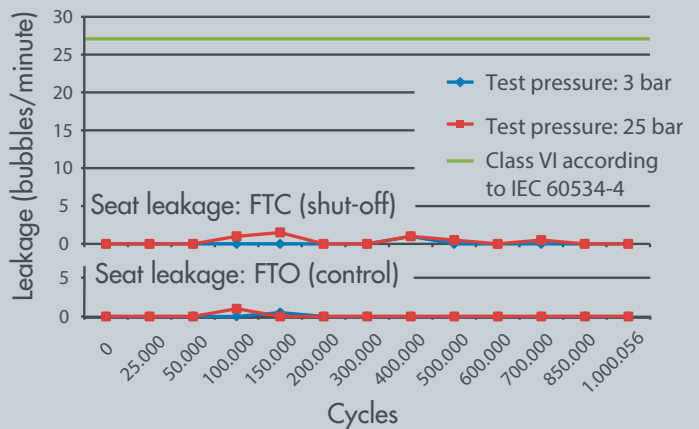

External leakage results

After completing the test involving 1,000,056 cycles, fugitive emissions testing was performed with air at 25 bar using leak detection spray. No leakage was detected (bubble tight).

Type 3241 PSA

- 1 Meets strict fugitive emissions requirements**
 - PTFE-carbon packing meets the fugitive emissions requirements according to VDI 2440 and, as a result, fulfills the requirements of TA Luft (German technical instructions on air quality control)
- 2 Reduced noise levels**
 - Body and trim design with optimized flow contours
 - Bi-directional flow divider (optional)
- 3 Low levels of vibration during operation**
 - V-port plug with asymmetric ports for stable guidance
 - Pressure-balanced plug to reduce the actuator thrust required (optional)
- 4 Tight shut-off**
 - Plug and seat with soft seal (leakage class VI) or high-performance metal-to-metal seal (leakage class V)
- 5 Bi-directional flow**
 - Seat and plug geometry designed for frequent changes of the flow direction
- 6 Easy maintenance**
 - Undivided valve bonnet
- 7 Low wear**
 - Reinforced bushing
 - Plug stem with additional reinforcement for valves in size DN 65 and larger
- 8 Rugged body**
 - Valve body available in cast steel, forged steel, or forged stainless steel
- 9 Type 3271 and Type 3277 Pneumatic Actuators**
 - Powerful thrust at high stroking speed
 - Low overall height thanks to off-center arrangement of the actuator springs
 - Minimized air consumption thanks to one-piece diaphragm
 - Quick and simple attachment without the need for special tools
 - Direct attachment of accessories (Type 3277)
- 10 Type 3275 Pneumatic Piston Actuator**
 - Powerful thrust thanks to supply pressure of max. 6 bar
 - Low overall height
 - Direct attachment of accessories on additional yoke with concealed travel pick-off

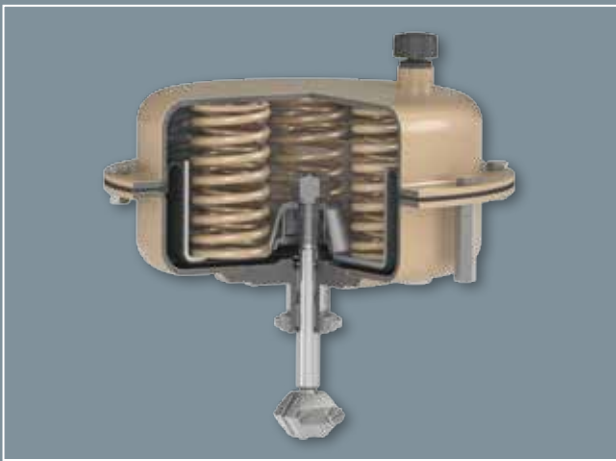

Type 3271 or Type 3277 **9**

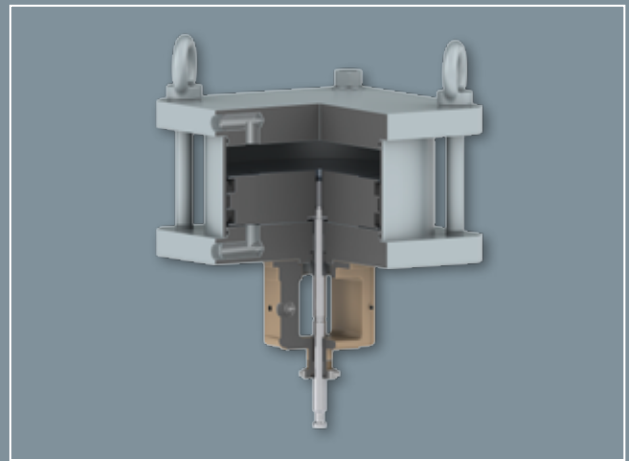

10 Type 3275

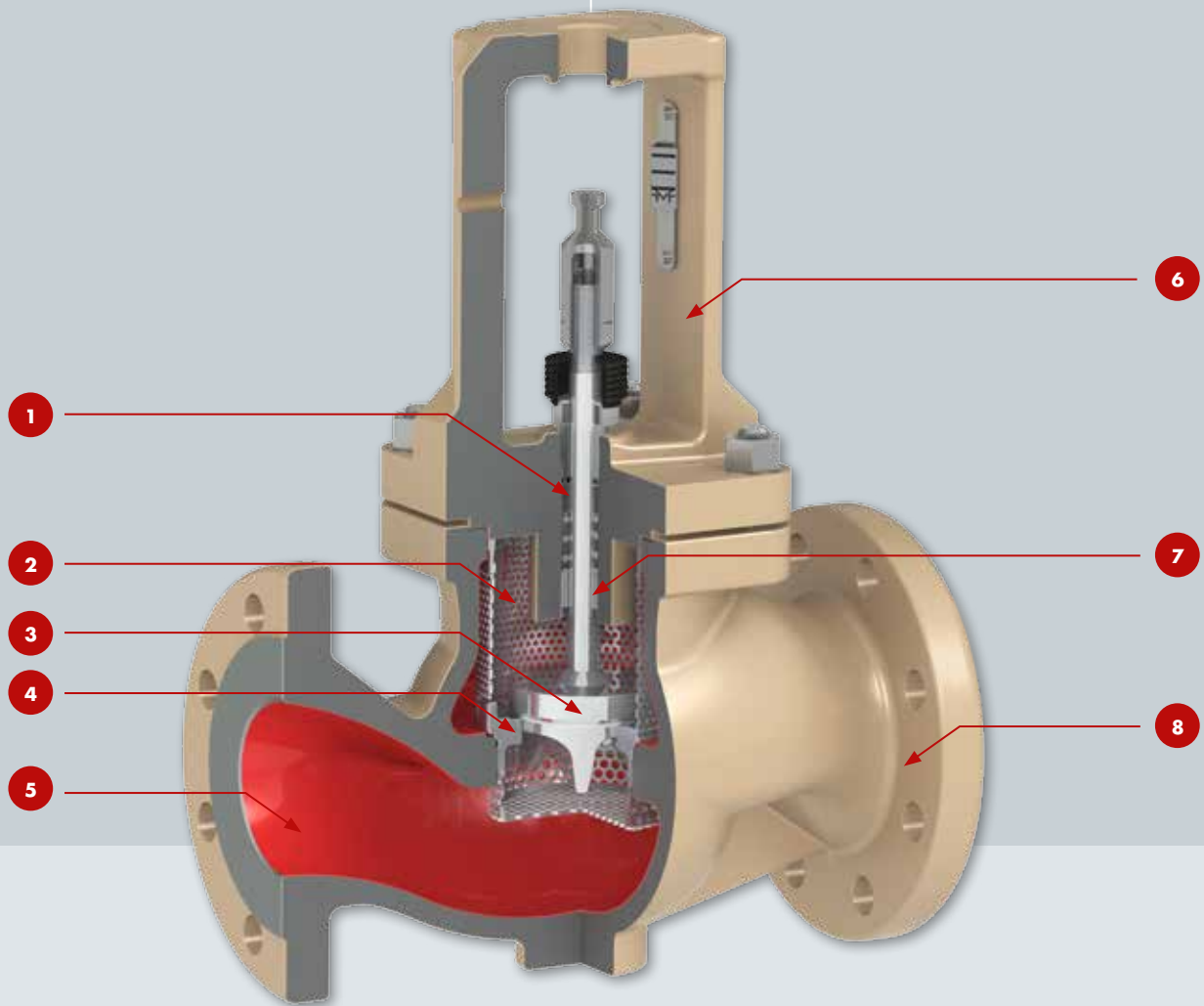

ROTARY VALVE

Type 14p PSA

- 1 Heavy-duty design**
 - Rugged design with a sturdy built valve body and double-eccentric butterfly disk
- 2 Meets strict fugitive emissions requirements**
 - Proven SAMSON PFEIFFER design with a V-ring packing loaded by disk springs
- 3 Low wear**
 - Double offset with low breakaway and closing torques
- 4 Tight bi-directional shut-off for gases**
 - Special elastomer seat ring in combination with a coated disk ring
- 5 Bi-directional flow**
 - Disk geometry designed for frequent changes of the flow direction
- 6 Flexible face-to-face dimensions**
 - Standard according to EN 558 R16 and API 609
 - Special FTF dimensions possible on customer request
- 7 SAMSON PFEIFFER Type 31a Rotary Actuator**
 - Design for particularly fast stroking speeds
 - Tested far beyond one million cycles
 - Standardized attachment of accessories and simple upgrading

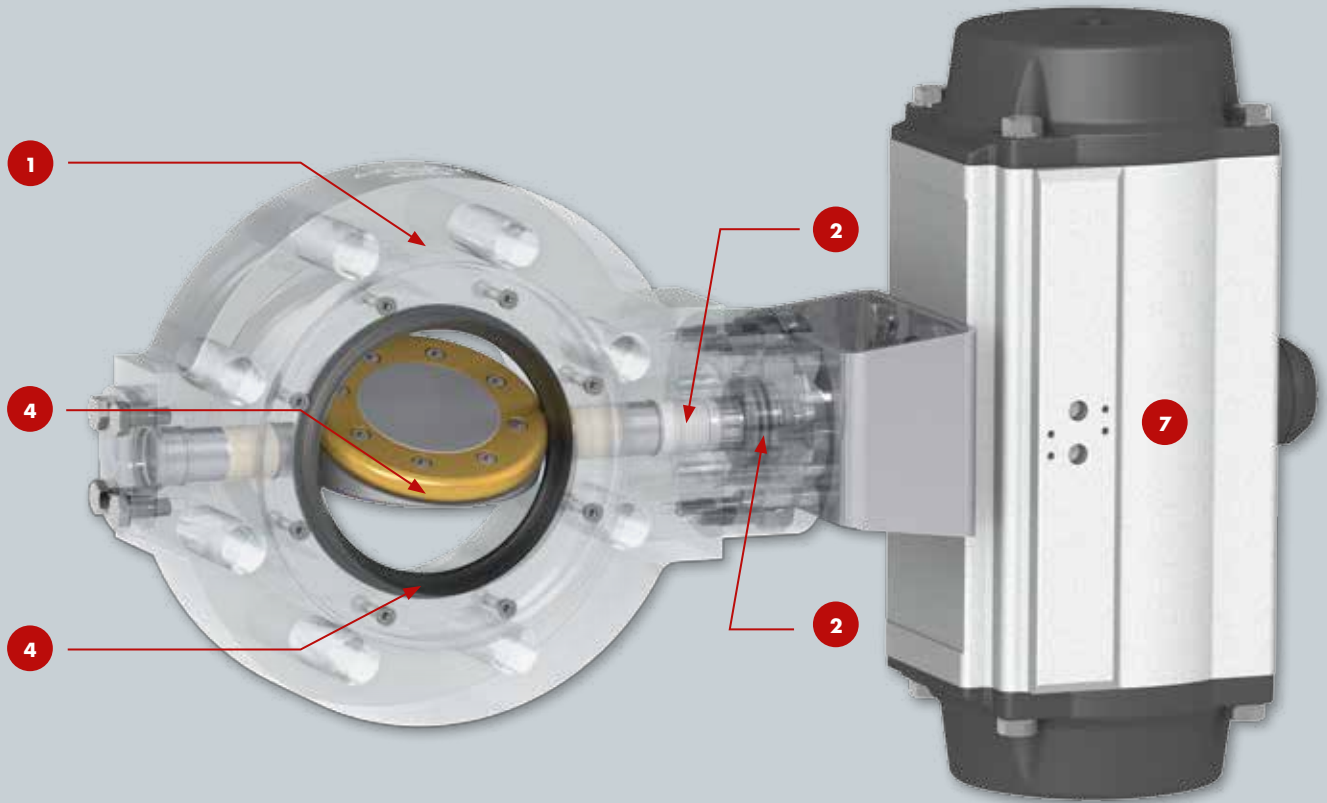
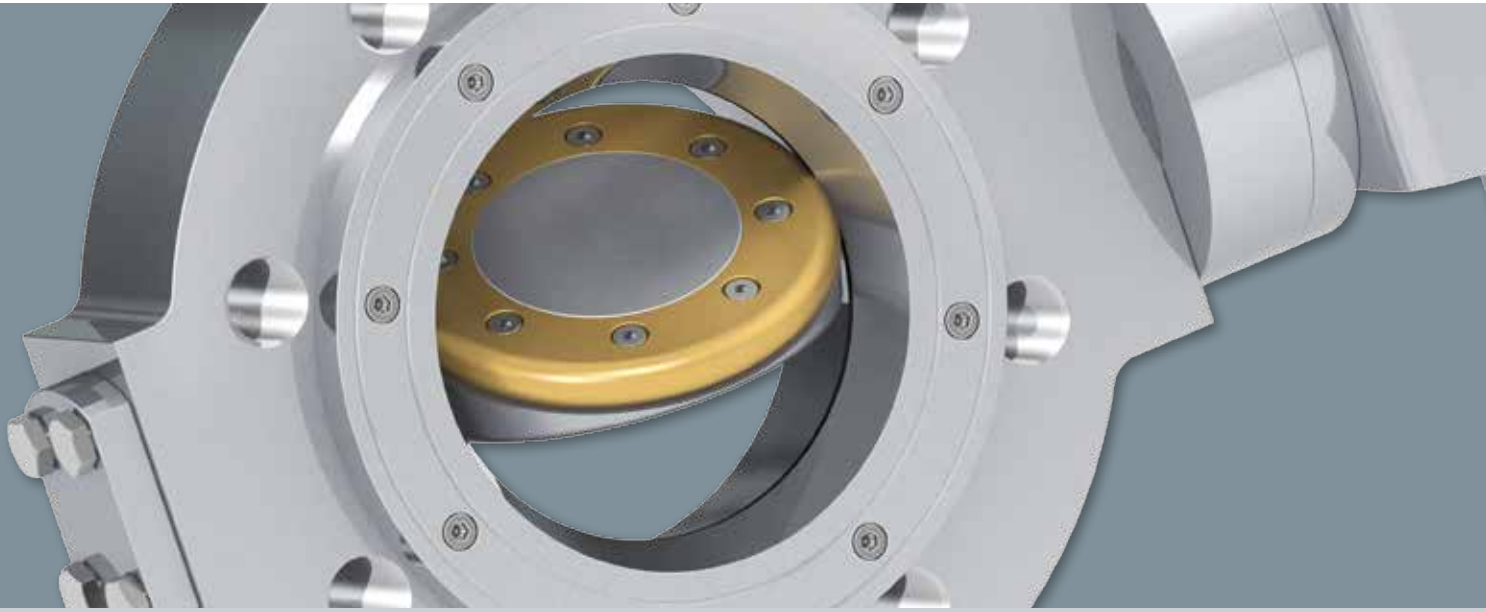

Valve engineering from a single source

SAMSON offers the full range of high-quality and state-of-the-art control equipment for industrial processes. Our portfolio includes control valves and a full range of valve accessories:

- Positioners
- Solenoid valves
- Limit switches
- Volume boosters
- Lock-up valves
- Supply pressure regulators
- Filter regulators
- Service units
- Reversing amplifiers
- Quick exhaust valves

The use of smart, digital positioners allows the control valve to be connected to process control systems. Extensive diagnostic functions integrated into the positioner support predictive maintenance.

TROVIS SOLUTION

Asset management system for pneumatic control valves equipped with smart SAMSON positioners

- Optimized plant performance
- Predictive maintenance
- Documentation of the tag history and identification data

SAMSON assists you in selecting and configuring the right equipment to suit your control requirements.

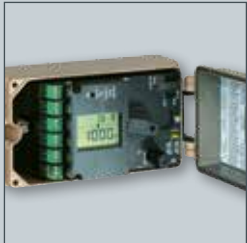



SAMSON

SAMSON

PRESSURE SWING ADSORPTION



● Production sites ● Subsidiaries

SAMSON AKTIENGESELLSCHAFT
Weismuellerstrasse 3 · 60314 Frankfurt am Main, Germany
Phone: +49 69 4009-0 · Fax: +49 69 4009-1507
E-mail: samson@samson.de · Internet: www.samson.de

PFEIFFER Chemie-Armaturenbau
Hooghe Weg 41 · 47906 Kempen, Germany
Phone: +49 2152 2005-0 · Fax: +49 2152 1580
E-mail: vertrieb@pfeiffer-armaturen.com
Internet: www.pfeiffer-armaturen.com

SMART IN FLOW CONTROL.