

# versaflex

## Flat Top Chain Conveyor System

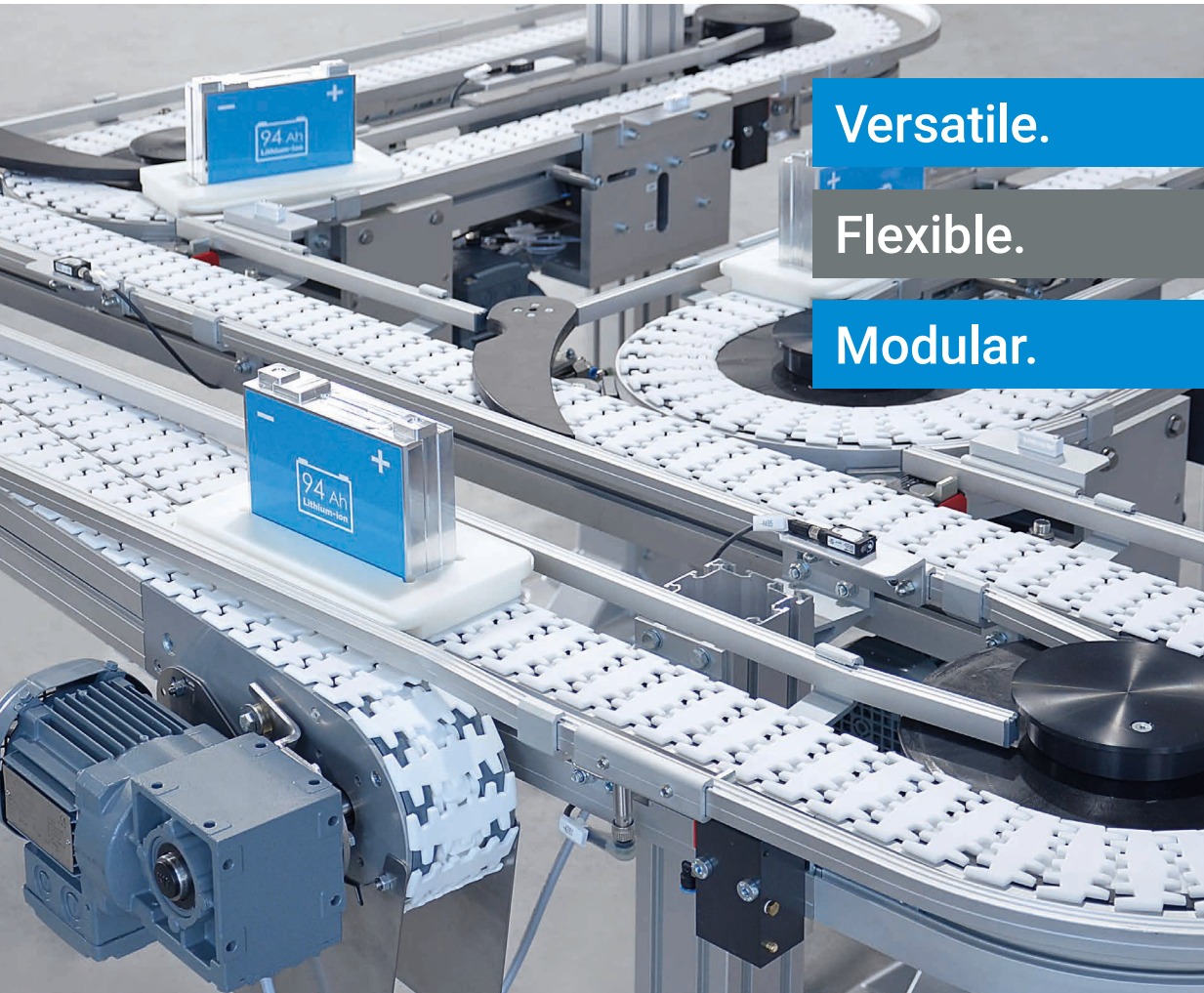

Versatile.

Flexible.

Modular.

## Versaflex – versatile and flexible



» Flexible solution from  
the construction kit. «

The versatile and flexible flat top chain conveyor system Versaflex, formerly the plastic chain conveyor of E-M-M-A GmbH, features a modular design. The standardized modules and components make it simple and cost effective to integrate the system into any production process, as well as to adapt and expand it. Versaflex is a conveyor system that grows with your requirements. Moreover, it is compatible with systems that are currently available on the market.

The single-track design and curve radii starting at 150 mm allow complex track designs within a three dimensional space. The chain runs on wear strips to ensure low wear and can be operated at speeds of up to 50 m/min and system lengths up to 40 m with just one drive.

Whether as a turnkey solution or in an assembly kit, the system is extremely flexible and efficient with chain widths of 44 mm to 295 mm and a large selection of drives, bends, cleats, side rails and other accessories. Gentle transport and exact positioning using workpiece carriers is also available as standard.

Versaflex has been used very successfully for years in various industries and transports a wide variety of products reliably to their destination.



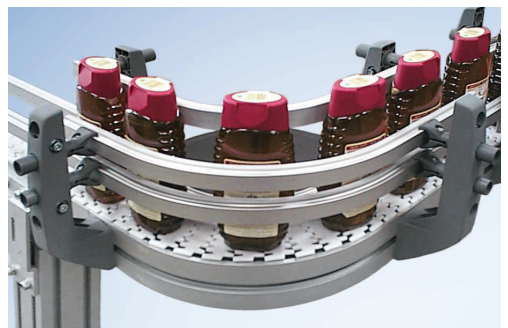
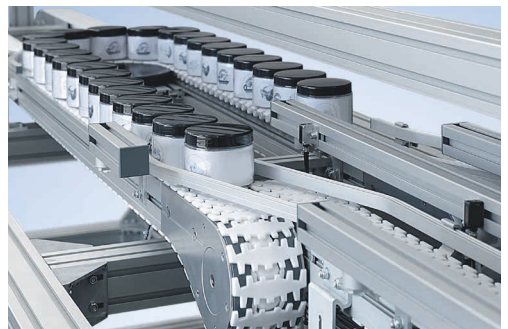
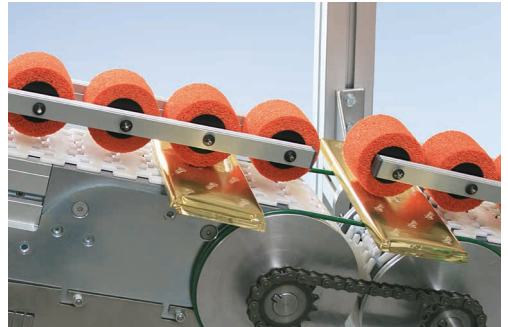
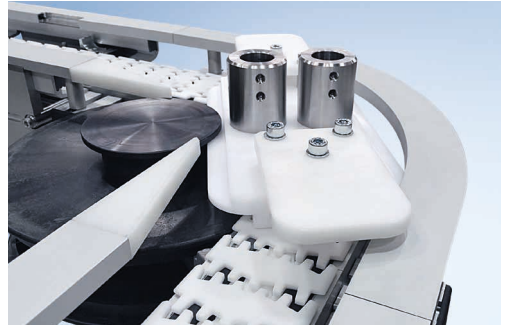

## Benefits of Versaflex

- Economical realisation of complex track designs
- Simple and fast configuration and commissioning
- Suitable for all industries and compatible with existing systems
- Modular system of standardized components
- Turnkey or as assembly kit
- User friendly and low maintenance
- Can be quickly adapted to new production and environmental conditions
- Saves energy and space
- Accessories, side rails etc. can be attached in the slots on the conveyor frame profile

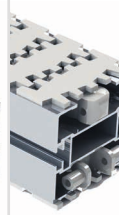
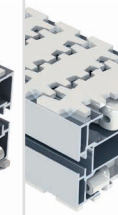
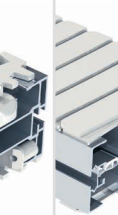

# Versaflex – versatile and flexible

## Overview of variants

System	A04*	A06	A08	A10	A17	A29
						
<b>Conveyor</b>						
System width [mm]	45	65	85	105	182	300
System height incl. chain [mm]	72	73	85	86	95	95
Total load max. [kg]	150	150	200	200	200	200
Conveyor length max. [m]	30	40	30	30	30	30
Conveyor speed max. [m/min]**	50	50	50	50	50	50
<b>Chain</b>						
Chain width [mm]	44	63	83	103	175	295
Chain pitch [mm]	25,4	25,4	33,5	35,5	33,5	33,5
Chain traction force [N]	500	500	1250	1250	1250	1250
<b>Product</b>						
Product width [mm]	10-80	15-140	20-200	25-300	70-400	70-400
Product weight horizontal max. [kg]	2	10	15	20	15	15
Product weight rising max. [kg]	1	2	10	15	10	10

\* also available as variant A045 with a system height of 52 mm for compact applications

\*\* higher conveying speeds on request

## The conveyor chain

The conveyor chains are made from the material POM and are available in a wide variety of designs for virtually all applications – with an adhesive surface for inclines, with steel covering for sharp-edged parts or flocked for transporting very delicate items. In addition, a large number of different cleats are available – rollers in a wide range of dimensions for accumulating products, or flexible cleats for implementing clamping conveyors. Furthermore, chain links with embedded magnets can be used to transport magnetizable parts.

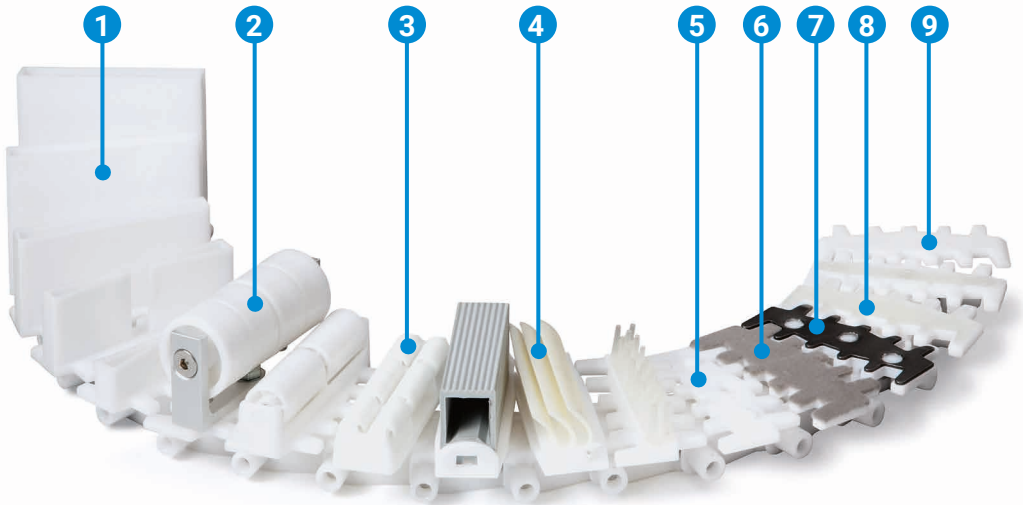

- 1 Cleated chain
- 2 Cleated roller chain
- 3 Roller top chain
- 4 Flexible cleated chain or clamping elements
- 5 Universal chain for customised cams
- 6 Flocked chain
- 7 Steel top chain
- 8 Chain with adhesive surface
- 9 Plain chain

# Versaflex – modular and standardised

## The Benefits

- ✓ Economical realisation of complex track designs
- ✓ Simple and fast configuration and commissioning
- ✓ Suitable for all industries and compatible with existing systems



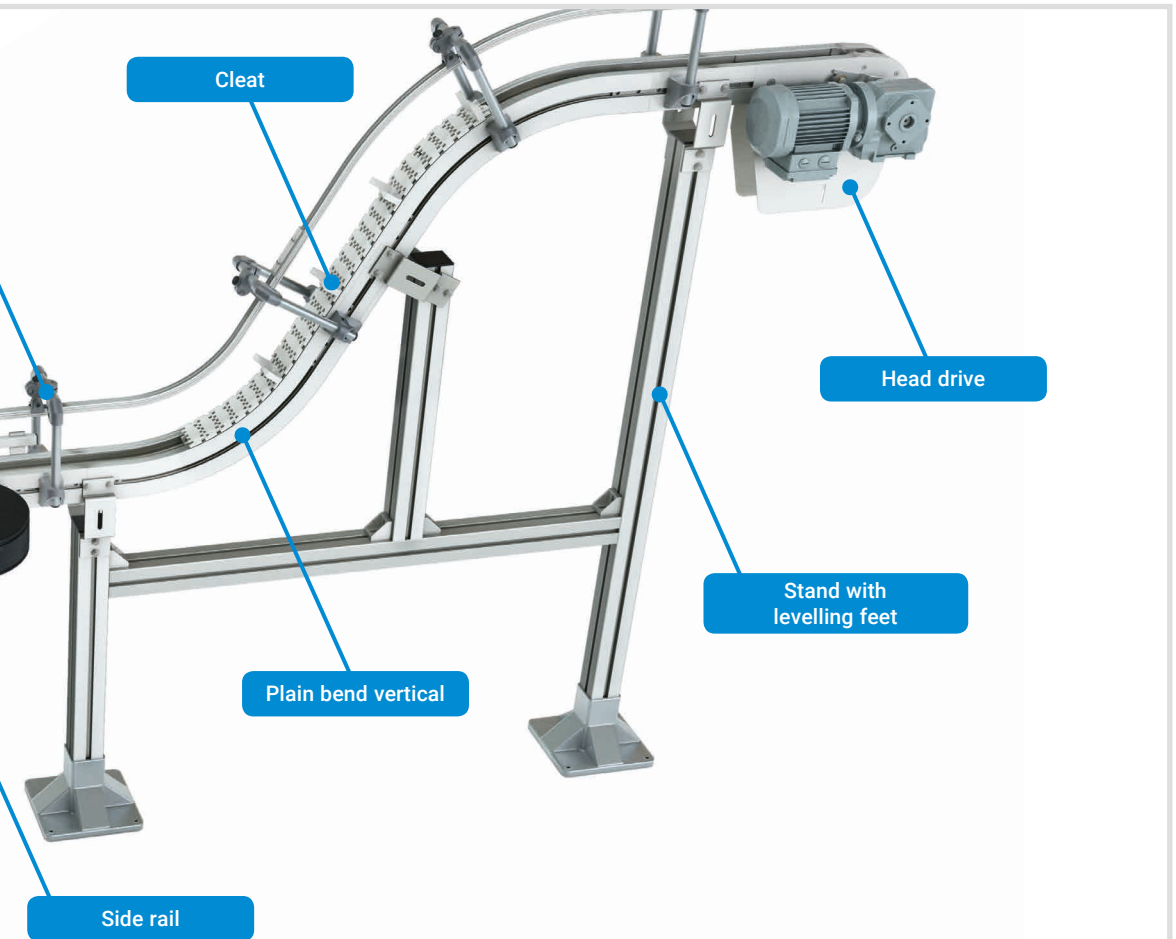

## Areas of application

Primary and secondary-packaged products from, among others, the food, pharmaceutical, chemical or consumer goods industry. Also for the transport of workpiece carriers in assembly lines e.g. of the automotive industry and for the linking of machines in the manufacturing industry.



# Versaflex – turnkey or as assembly kit

Complete system. Spare your own resources.

Horizontal conveyor

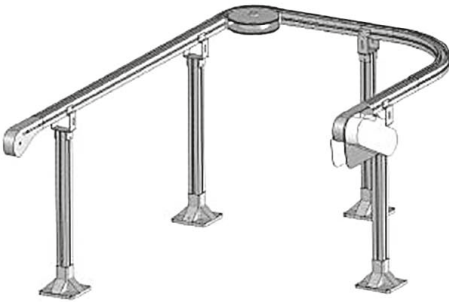

Conveyor with gradient

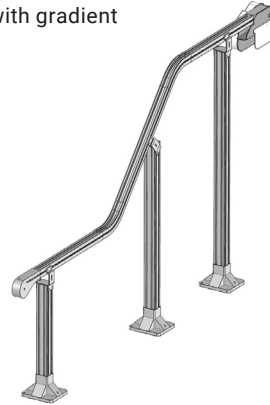

Clamping conveyor

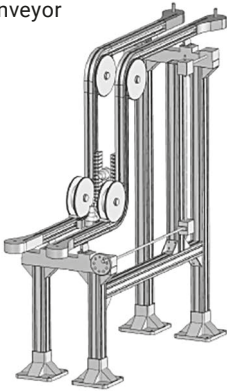

Alpine conveyors

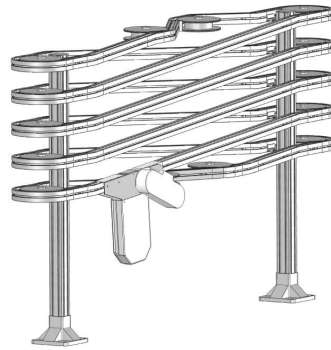

Workpiece carrier circulation

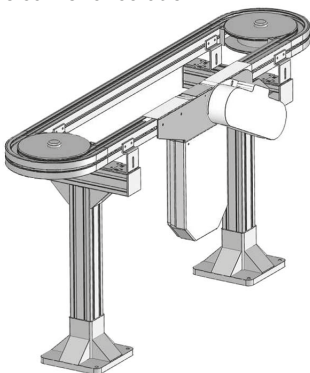

Vertical conveyor with guide rollers

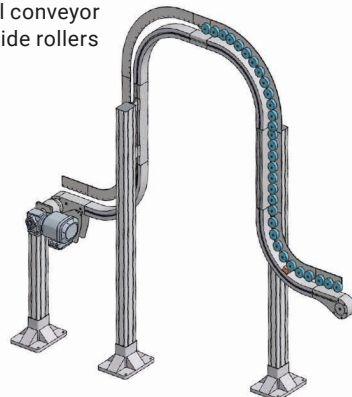



Module. Simply build yourself.

Chains and cleats

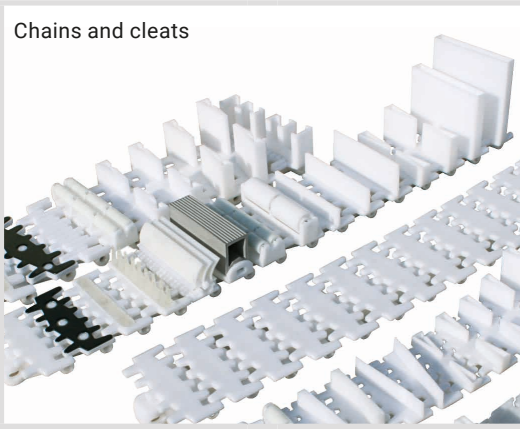

Profiles and wear strips

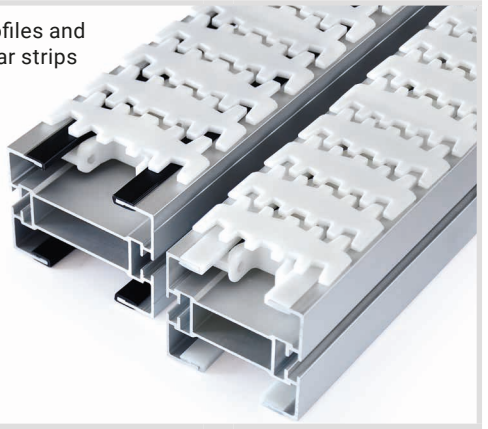

Drives and tails

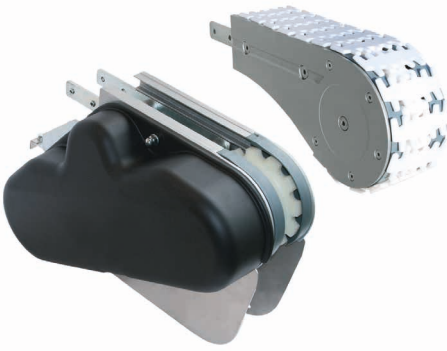

Curves and bends

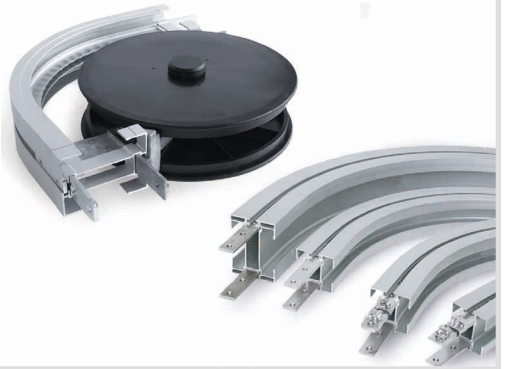

Side rails

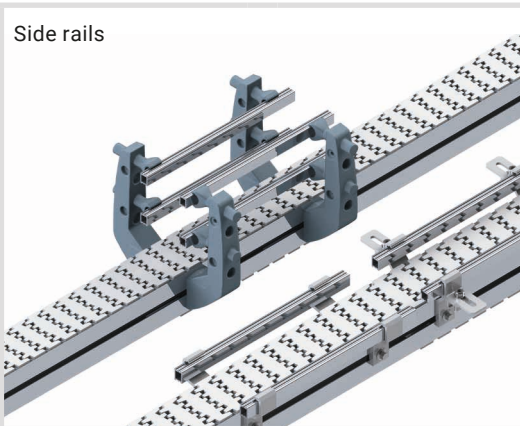

Stands



## Versaflex – also as a workpiece carrier system

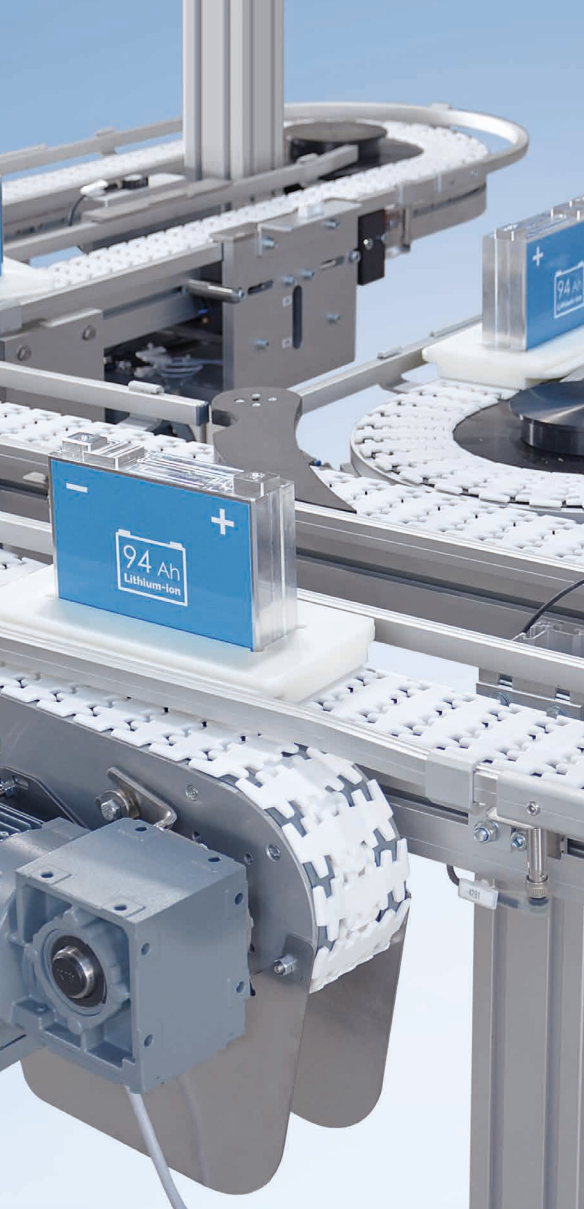

» Safe solution for automated processes. «

To ensure the precise positioning of products, workpiece carriers can also be transported on the A08 system. As described above, the system is 85 mm wide (chain width 83 mm) and is designed for products weighing up to 10 kg per carrier. The carriers have a standard width of 150 mm and are guided by side rails and positioned exactly in three levels in the locating stations. So the products are fixed, buffered and transported gently, safely and accurately.

The workpiece carrier can be customised and equipped with individual fixtures. The locating station can be freely positioned without changing the side rails. A positional accuracy of  $\pm 0.1$  mm is achieved. Therefore the workpiece carrier is lifted off the conveyor chain.

## Benefits of Versaflex workpiece carrier system

- Simple and accurate positioning for automated processes
- Stability even for products with unfavorable geometry
- Gentle product transport also for sensitive product surfaces
- Safe transport even with changes in position
- Higher machine autonomy
- Buffer function for cycle decoupling in manufacturing process

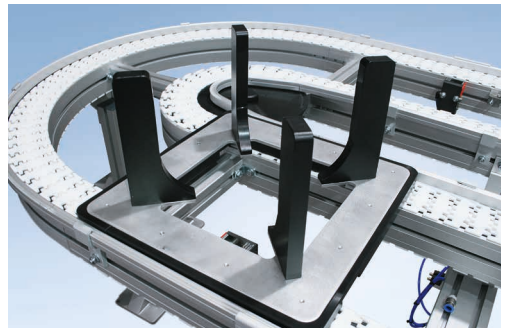
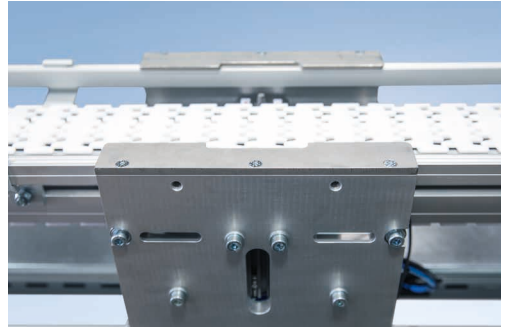

# Versaflex – used very successfully in all areas



4-track Versaflex flat top chain conveyor A06 with cleats



Versaflex flat top chain conveyor with guide rollers for vertical transport

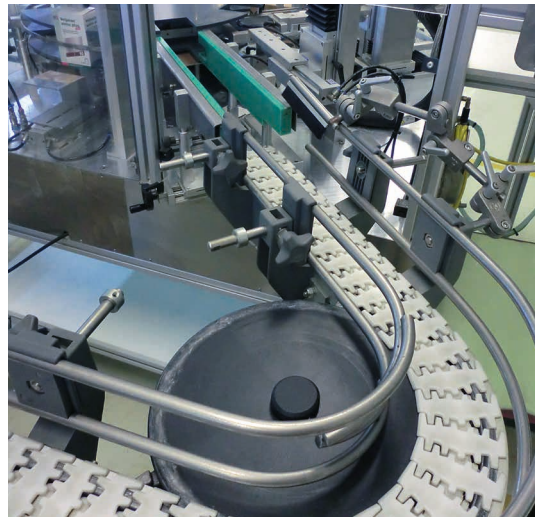

Versaflex flat top chain conveyor with wheel bend and side rail



Versaflex flat top chain conveyor  
as clamping conveyor

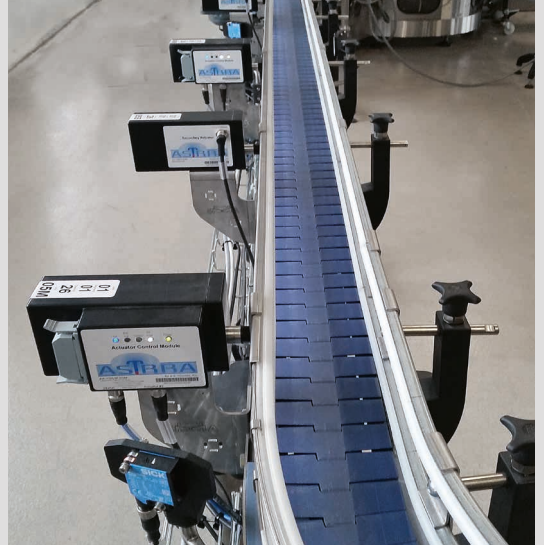

Automatically adjustable  
side rails ASTRA



Versaflex flat top chain conveyor  
as a parallel multi-line system

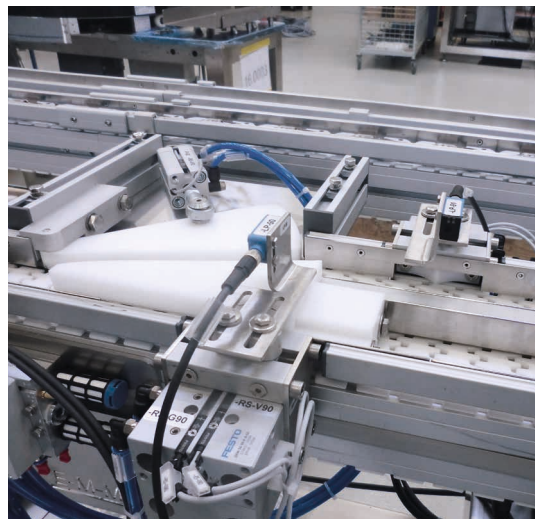

Versaflex flat top chain conveyor  
with customised separation

## Our service – your benefit



» Dependable consulting and technical support throughout the entire life cycle. «

Productivity is the key to your company's success in a globally competitive market. Your machines and systems must run continuously and dependably throughout the entire life cycle if you want to be able to fulfil your customer's requirements quickly, efficiently and ensure the utmost quality at all times. We offer comprehensive services to assist you at every stage of your project.

Based on your specific application, the mk field team provides on-site consulting and helps with planning, designing and implementation. Our qualified fitters are available to perform commissioning on site to ensure that production begins quickly and smoothly.

We aim to maintain uninterrupted system availability during service activities. Whether maintenance, servicing or spare parts supply, unforeseen interruptions are kept to a minimum. Remote diagnostics systems simplify and accelerate maintenance, eliminating downtimes and unnecessary costs. We offer customised maintenance agreements for various customer requirements depending on whether you use single components and modules in your machine or complete systems in your production line.

Maschinenbau Kitz, the parent company of the mk Technology Group, is one of the leading suppliers of components, modules and systems for factory automation. With our dense production sales and service network consisting of subsidiaries, sales partners and external service providers, we guarantee our

customers fast access to our expert advice and outstanding products. Our more than 450 highly qualified and dedicated employees work to fulfil customer orders with precision and dependability in over 28,000 m<sup>2</sup> of production area space.

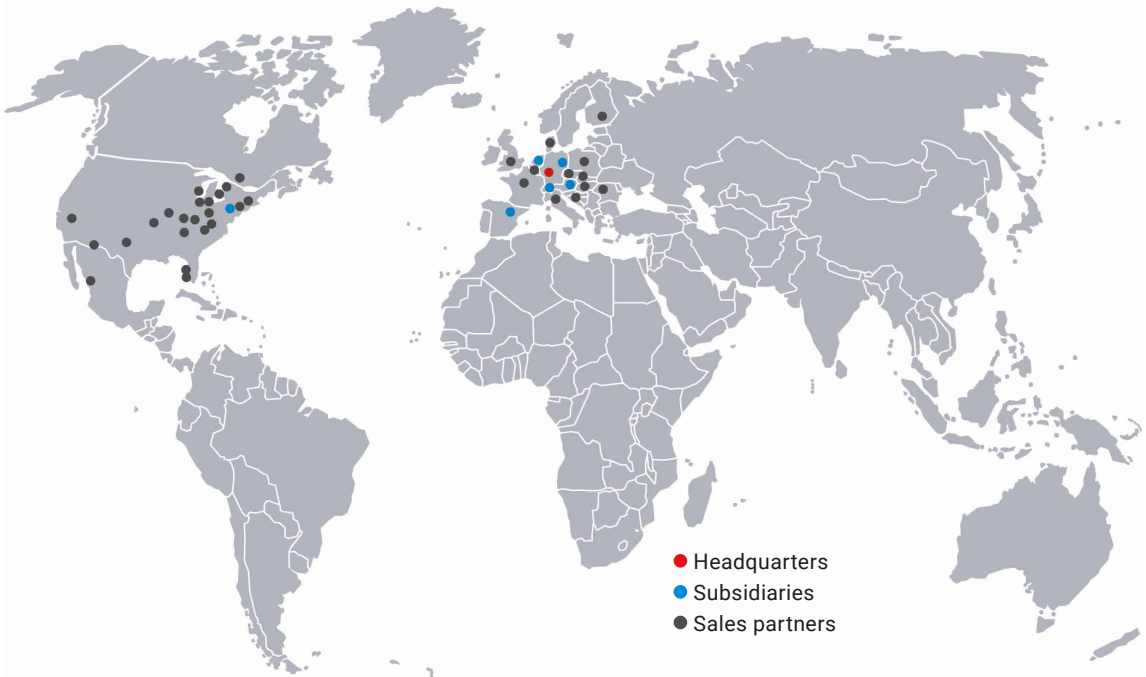

## Headquarters

**Maschinenbau Kitz GmbH**  
Ampèrestrasse 18  
53844 Troisdorf,  
Germany  
info@mk-group.com  
www.mk-group.com

## Subsidiaries

**mkf GmbH**  
Lindenstrasse 1  
07589 Lederhose,  
Germany  
info@mkf-automation.de  
www.mkf-automation.de

**mk Products B.V.**  
Windmolen 12  
7609 NN Almelo,  
Netherlands  
info@mkproducts.nl  
www.mkproducts.nl

**E-M-M-A GmbH**  
IZ Nö Süd Strasse 2a/M8  
2351 Wr. Neudorf,  
Austria  
info@e-m-m-a.eu  
www.e-m-m-a.eu

**mk North America Inc.**  
105 Highland Park Drive  
Bloomfield, CT 06002,  
USA  
info@mknorthamerica.com  
www.mknorthamerica.com

**mk Kitz Hispania S.L.**  
C/Peña Oroel, s/n.  
50410 Cuarte de  
Huerva (Zaragoza),  
Spain  
info@mkhispania.es  
www.mkhispania.es

**Promec Automation AG**  
Rolliweg 21  
2543 Lengnau,  
Switzerland  
info@promec-automation.ch  
www.promec-automation.ch



Maschinenbau Kitz GmbH  
Headquarters of the  
mk Technology Group

Ampèrestraße 18  
53844 Troisdorf  
Germany

Tel +49 228 4598-0  
info@mk-group.com  
www.mk-group.com

