

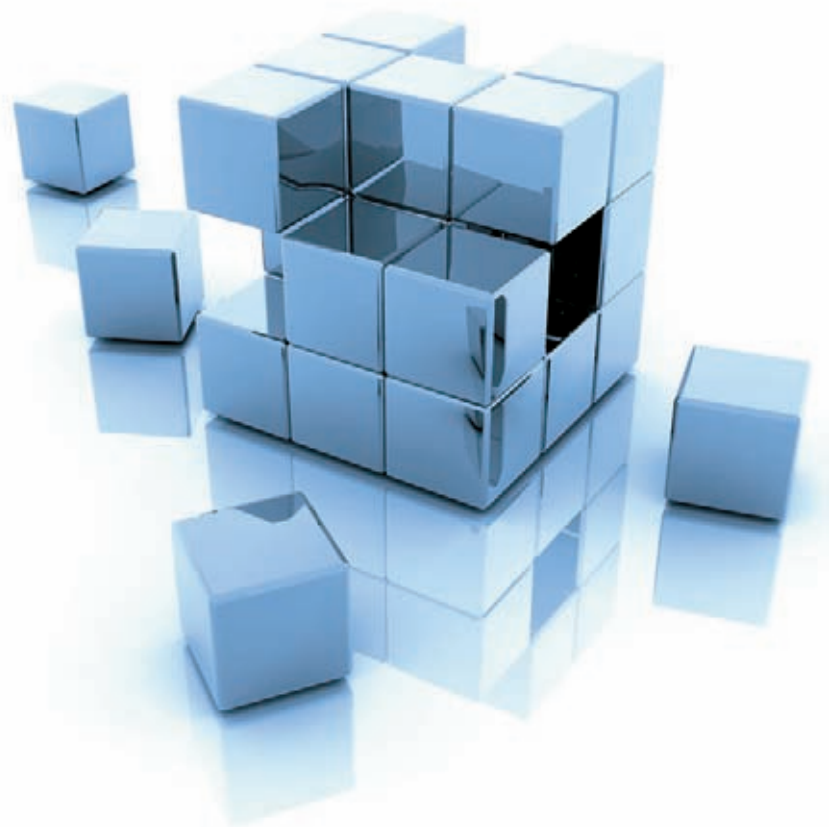

InterFocus



building laboratory solutions

lab line
research

lab line
education

lab line
healthcare

lab line
turnkey

How to use the interactive catalogue

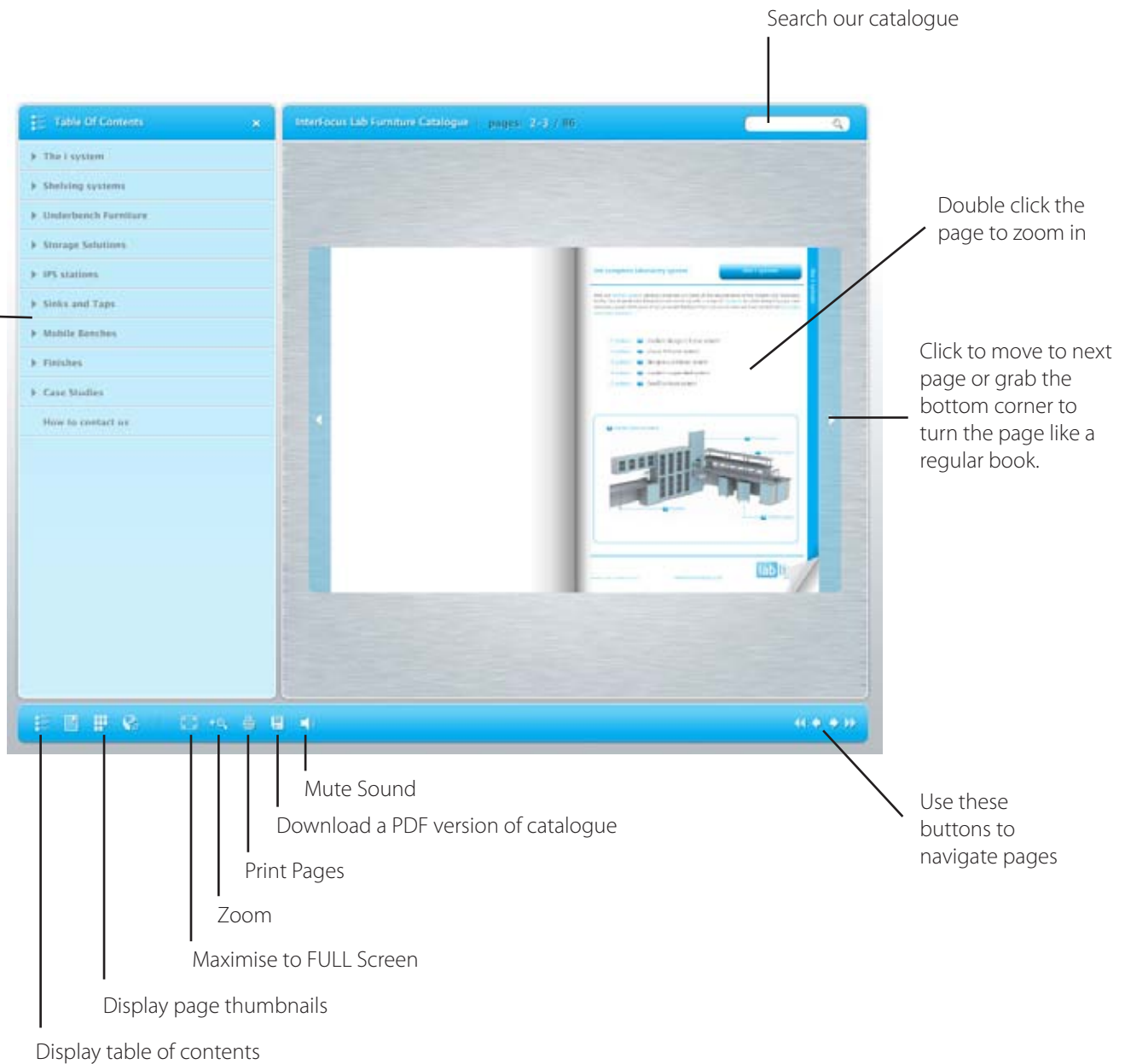

With our [labline i system](#) product range we can cover all the requirements of the modern day laboratory facility. Our experienced designers have come up with a range of [i systems](#) to make designing your new laboratory easier. With years of accumulated feedback from actual lab users we have created the [complete laboratory solution](#).

- i1 system > modern design C-frame system
- i2 system > classic H-frame system
- i3 system > designer cantilever system
- i4 system > modern suspended system
- i5 system > fixed furniture system

> example system integration

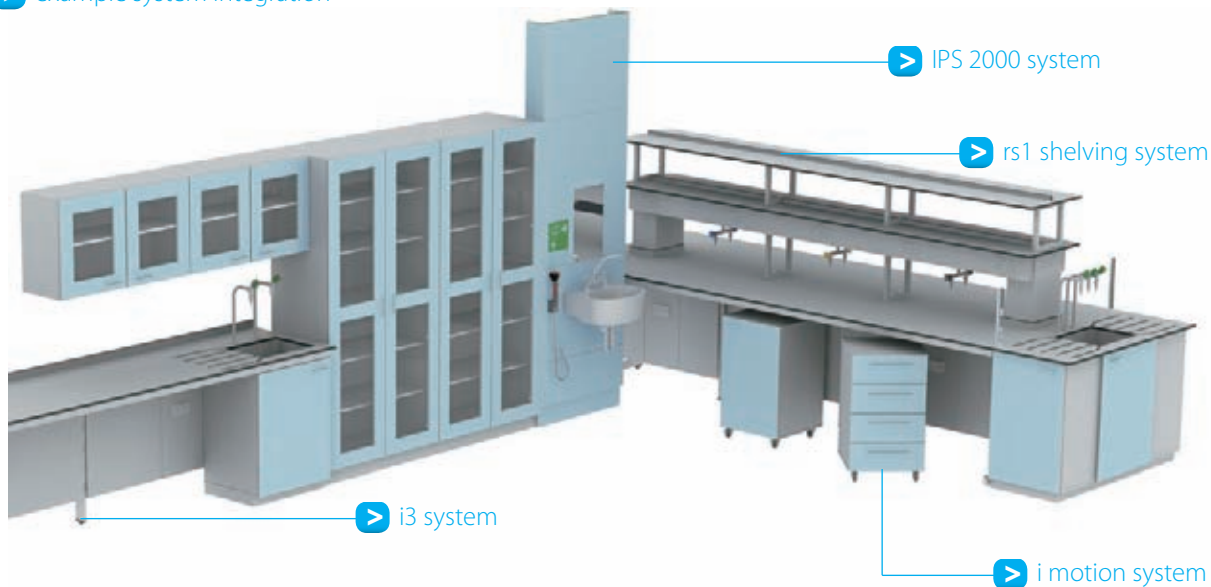



- > **The i1 system**
Ideal for a laboratory that requires a modern cantilevered appearance but needs added strength for equipment.
Made from high quality powder coated steel.
- > **The i1 system** can be used with all InterFocus shelving and underbench furniture. Optional underbench panels can also be added to further enhance appearance and practicality.

i1 system

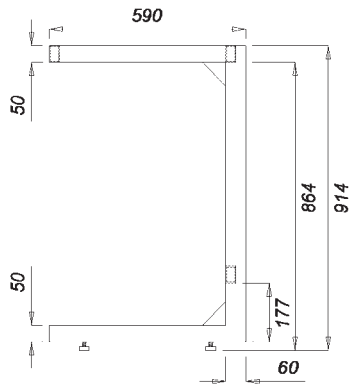

▶ The i1 system dimensions

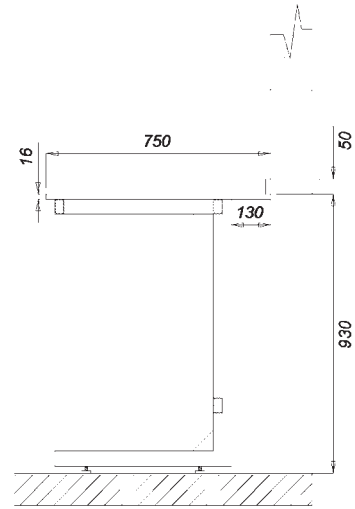

▶ The i1 system for a perimeter wall bench

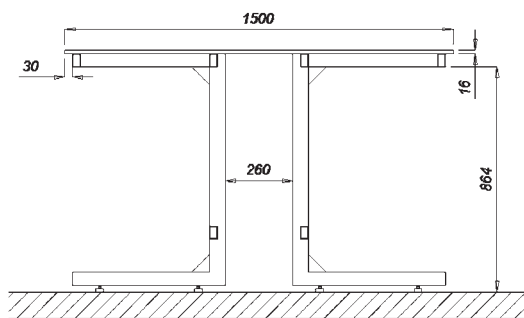

▶ The i1 system for a peninsular bench

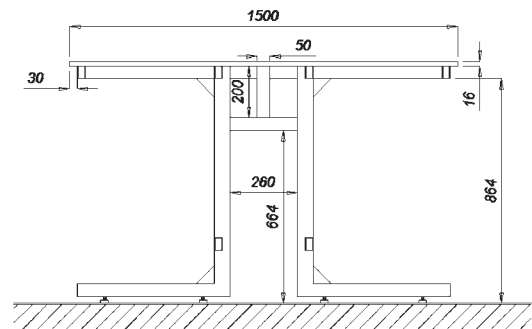

▶ The i1 system for the top rail shelving option



- > **The i2 system**
Creates a classic look laboratory. Ideal for a laboratory that requires a heavy duty base for large equipment.
Made from high quality powder coated steel.
- > **The i2 system** can be used with all InterFocus shelving systems, and underbench furniture.
Optional underbench panels can also be added to further enhance the appearance and practicality.

i2 system

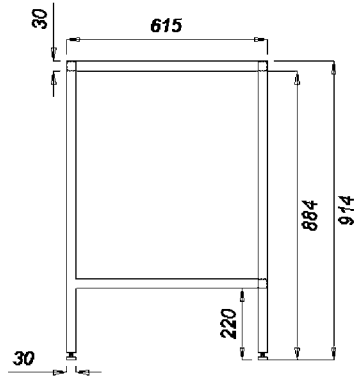

▶ The i2 system dimensions

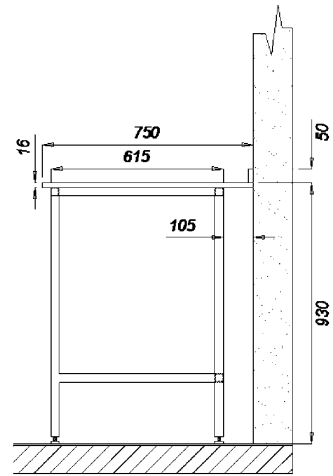

▶ The i2 system for a perimeter wall bench

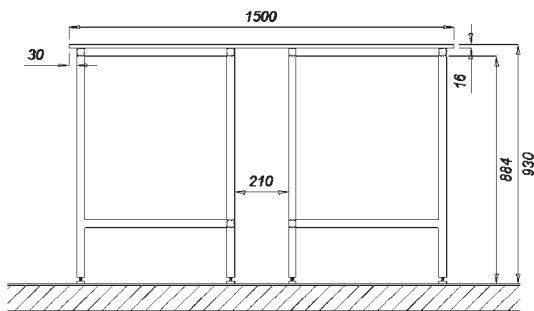

▶ The i2 system for a peninsular bench

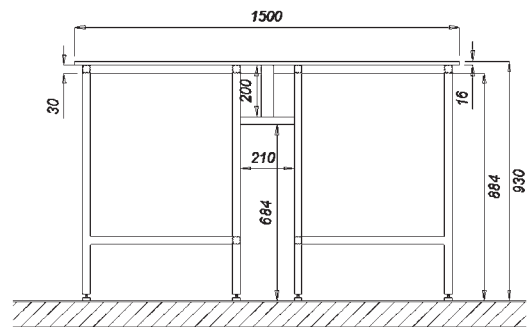

▶ The i2 system for the top rail shelving option



- > **The i3 system**
Creates an open versatile furniture system. Ideal for a laboratory that requires flexibility. With no legs to worry about this system is perfect for labs that need floor space for equipment.
Made from high quality powder coated steel.
- > **The i3 system** can be used with all InterFocus shelving systems, and underbench furniture.
Optional underbench panels can also be added to further enhance the appearance and practicality.

i3 system

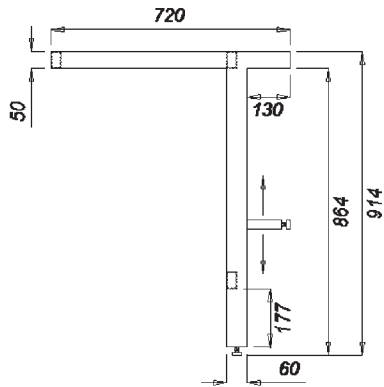

▶ The i3 system dimensions

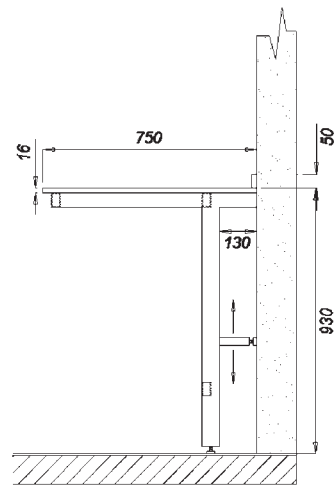

▶ The i3 system for a perimeter wall bench

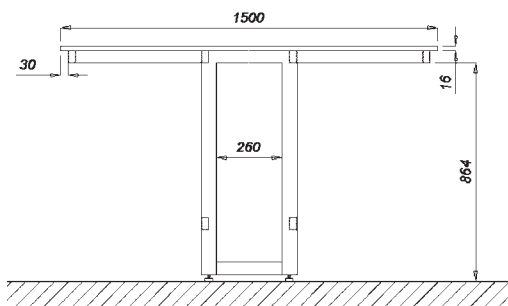

▶ The i3 system for a peninsular bench

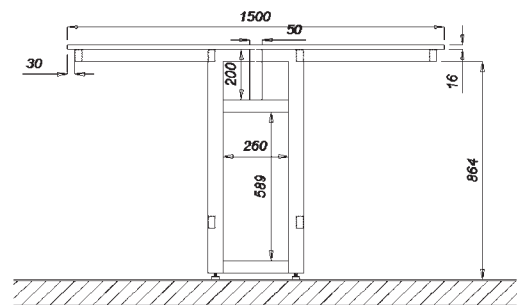

▶ The i3 system for the top rail shelving option



- > **The i4 system**
Designed for the laboratory that requires hygiene and constant cleaning. An ideal solution for Hospitals or infection control laboratories.
Made from high quality powder coated steel.
- > **The i4 system** can be used with all InterFocus shelving systems.
Optional underbench panels can also be added to further enhance the appearance and practicality.

i4 system

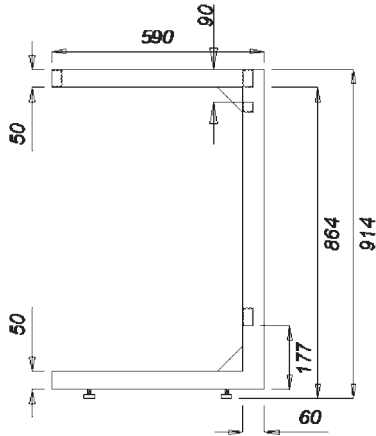

▶ The i4 system dimensions

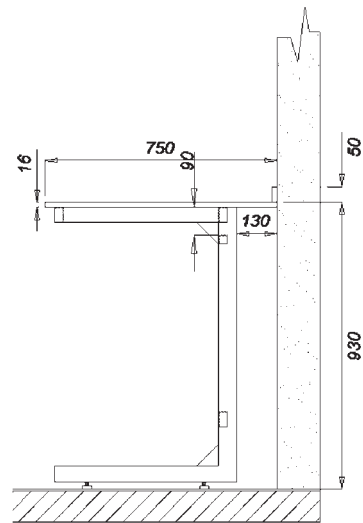

▶ The i4 system for a perimeter wall bench

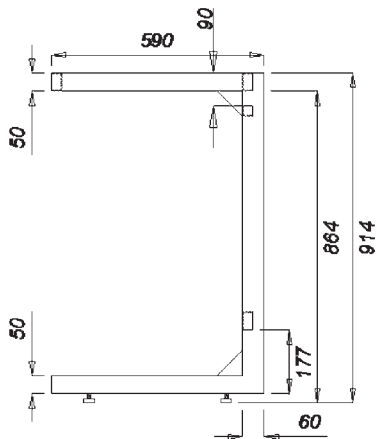

▶ The i4 system for a peninsular bench

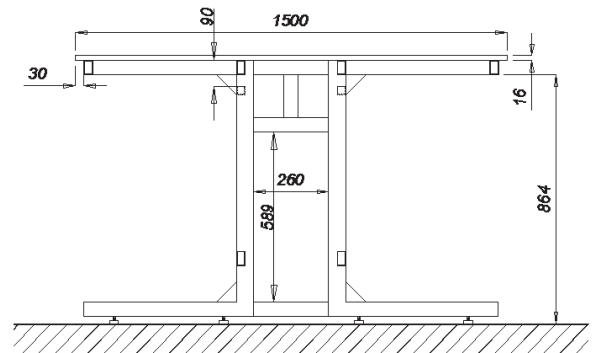

▶ The i4 system for the top rail shelving option

▶ The i4 system suspended units can also be hung from a cantilever i1 system frame



> The i5 system

A fixed furniture system. The worktops are fixed directly to the furniture. This creates a solid fitted appearance but is less flexible than a frame system. Ideal for a solid structure or for a laboratory that requires a rigid non movable layout.

> The i5 system can be used with all InterFocus shelving systems.

i5 system

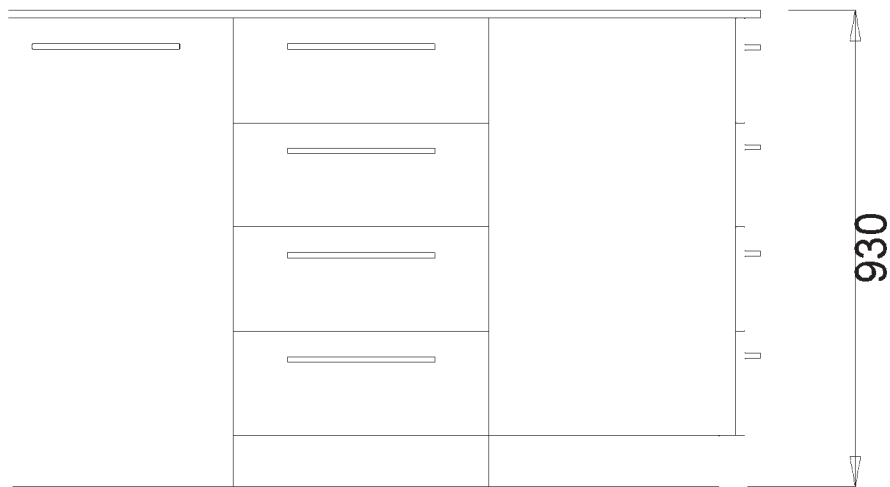

> The i5 system dimensions height

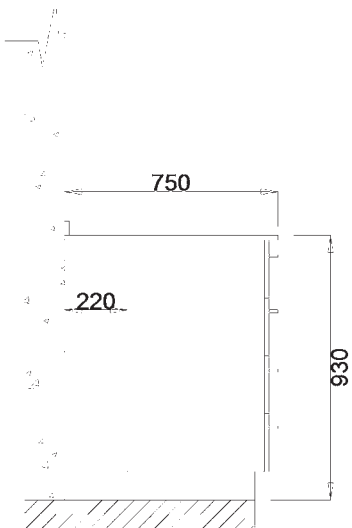

> The i5 system for a perimeter wall bench

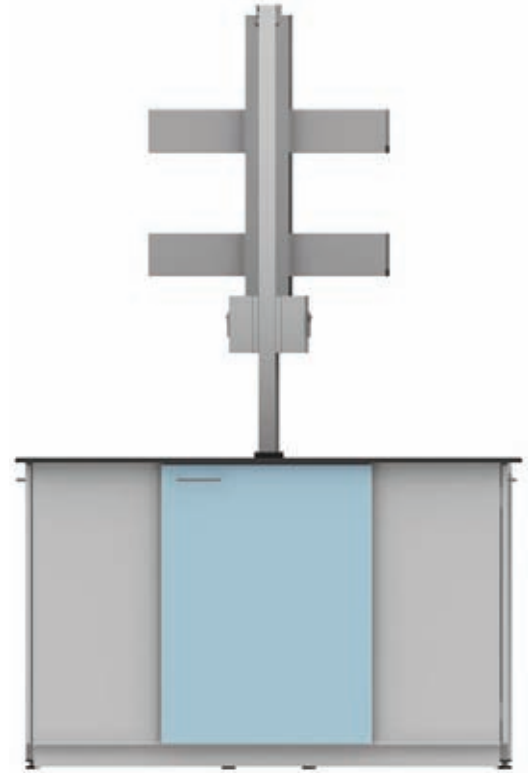



> The rs1 Reagent Shelf

A robust laboratory shelving system, the main section is manufactured in 3 mm edged melamine, with easy removable access panels for services. All supports are powder coated steel.

For electrical services, simply fix trunking to the outside of the main section.

If laboratory taps are required, these can be easily suspended from the main section.

> The rs1 shelving system can be used with all of the InterFocus bench systems.

The shelving can be manufactured in trespa or melamine and there is also a powder coated steel main section option if required for a specialist laboratory.

rs1 reagent shelving

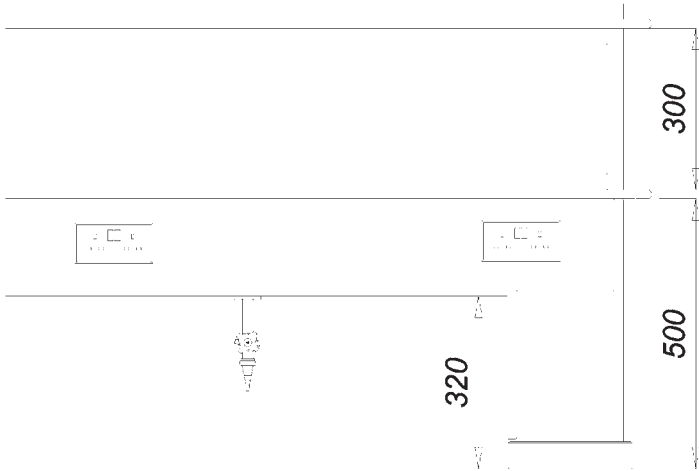

> The rs1 dimensions



> **The rs2 Reagent Shelf**

A robust laboratory shelving system, the main section is manufactured in 3 mm edged melamine, with easy removable access panels for services. All supports are powder coated steel.

For electrical services, simply fix trunking to the outside of the main section.

If laboratory taps are required, these can be easily suspended from the main section.

> **The rs2 shelving system can be used with all of the InterFocus bench systems.**

The shelving can be manufactured in trespa or melamine and there is also a powder coated steel main section option if required for a specialist laboratory.

rs2 reagent shelving

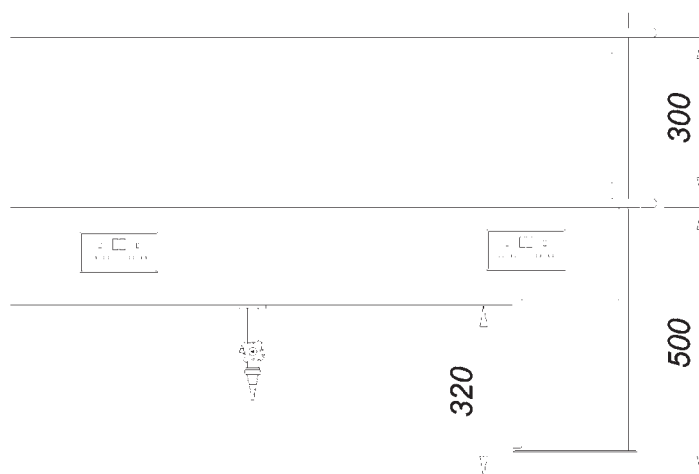

[▶ The rs2 dimensions](#)

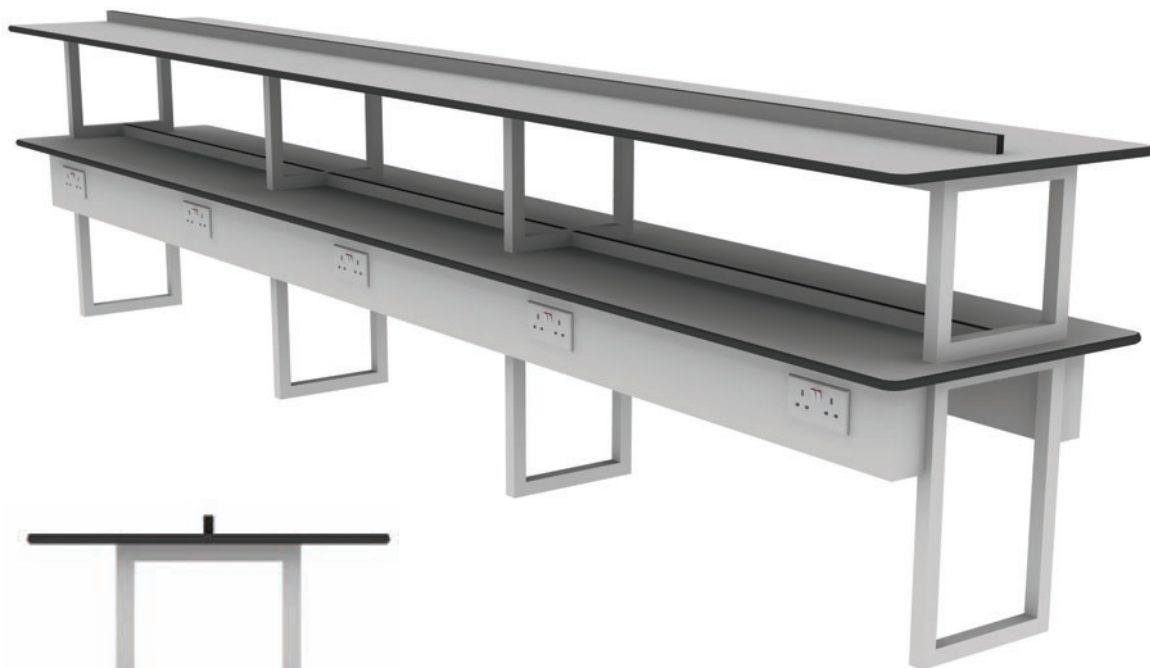

> The rs3 reagent shelf

A robust laboratory shelving system, All supports are powder coated steel.

For sockets, simply fix trunking to the outside of the steel uprights.

This system is not suitable for suspended services.

> The rs3 shelving system can be used with all of the InterFocus bench systems.

The shelving can be manufactured in trespa or melamine.

rs3 reagent shelving

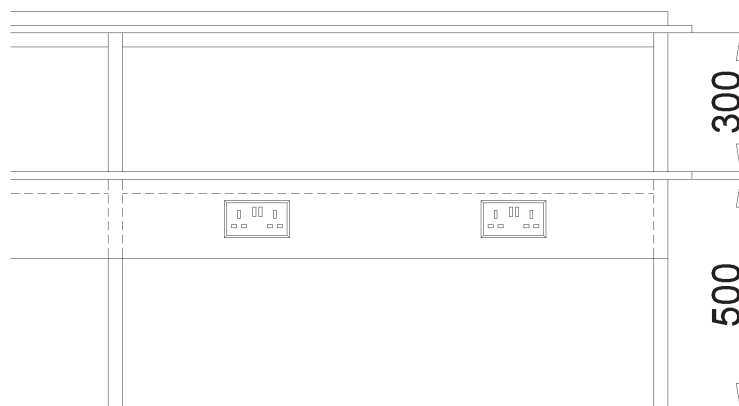

[▶ The rs3 dimensions](#)

a modern adjustable shelving system
using top rail

as1 adjustable shelving

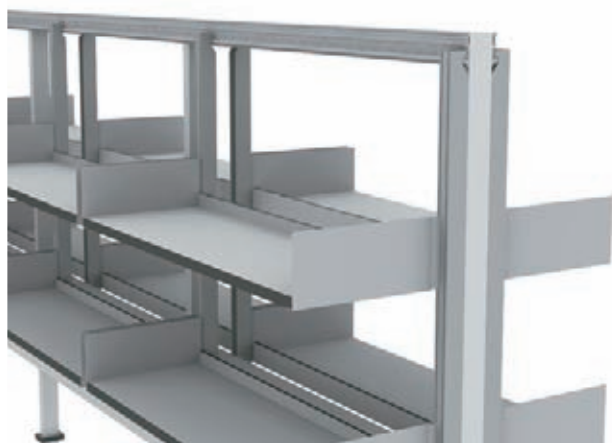

- > **The as1 adjustable shelving system**
A fully adjustable shelving system that can be adjusted for height and also have the flexibility of moving from side to side. Wall cabinets can also be attached to this system.
- > **The as1 shelving system can be used with all of the InterFocus bench systems.**
The shelving can be manufactured in tresspa or melamine.

Toprail are trademarks or registered trademarks of Toprail Systems Ltd. or its subsidiaries in United Kingdom and / or other countries.

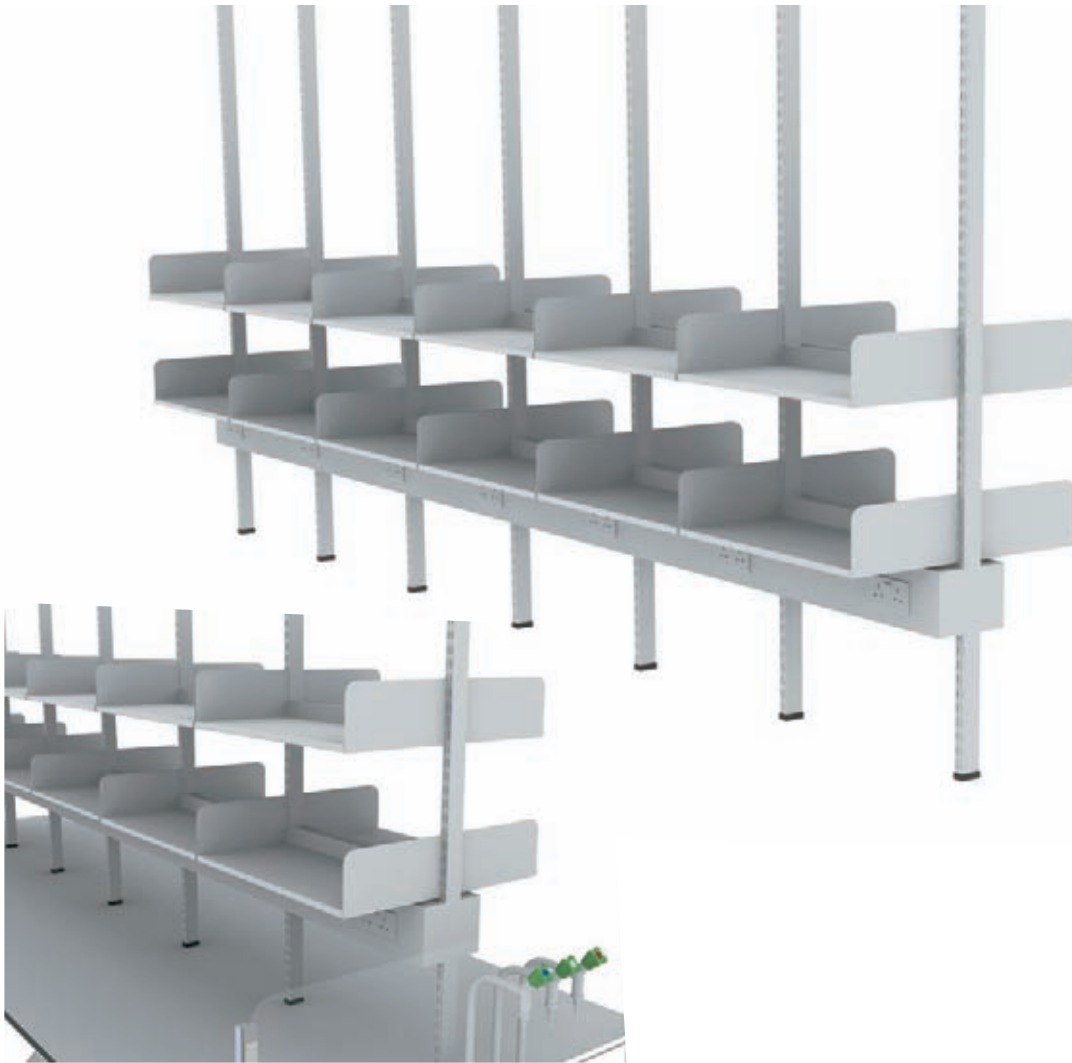

> **The as2 adjustable shelving system**

A fully adjustable shelving system that can be adjusted for height. This system is a cheaper alternative to the as1 system. A ceiling fixing is usually preferred with this type of system for rigidity, but there are alternatives if a ceiling fixing is not practical.

> **The as2 shelving system can be used with all of the InterFocus bench systems.**

The shelving can be manufactured in trespa or melamine.

underbench furniture

underbench furniture



The Labline research furniture range is a high quality robust and stylish laboratory furniture solution that will compliment any laboratory design project. Our Labline research range has been designed to cater for all your furniture and storage requirements.



- > Nylon runner with 25kg load bearing
- > Blum metal powder coated steel drawer sides. The bottom and back are 18mm MDF
- > Quality "D" Handle as standard, can be supplied in a range of colours. A recessed handle can also be specified
- > High quality castor with rubber tyre. Front castors lock

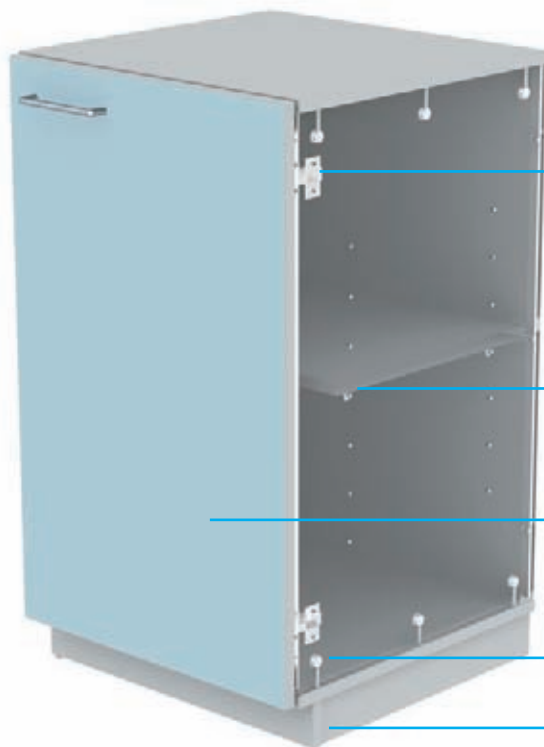

- > Fully adjustable high quality Blum hinge.
- > Fully adjustable 18mm MDF shelf, edged with 3mm PVC edging. Supported on steel shelf pins.
- > Drawer / door fronts are 18mm MDF with 3mm edging in high impact ABS for protection
- > Cam fix construction for a robust carcass.
- > Solid 18mm MDF plinth

The *i motion* underbench furniture range is a robust furniture system on braked castors that can easily be moved around your laboratory.



2D500M
2 Drawer Unit
500w x 500d x 850h



SC500LM
LH Cupboard Unit
500w x 500d x 850h



3D500M
3 Drawer Unit
500w x 500d x 850h



SC500RM
RH Cupboard Unit
500w x 500d x 850h



4D500M
4 Drawer Unit
500w x 500d x 850h



TR365LM
Tray Unit with LH Door
365w x 500d x 850h



DRL500LM
LH Drawline Cupboard
500w x 500d x 850h



TR365RM
Tray Unit with RH Door
365w x 500d x 850h



DRL500RM
RH Drawline Cupboard
500w x 500d x 850h



TR365OM
Open Tray Unit
365w x 480d x 850h



TR706M

Double Tray Unit
706w x 500d x 850h



DC1000M

Double Cupboard
1000w x 500d x 850h



TR706OM

Open Tray Unit
706w x 480d x 850h



DRL1000M

DbL. Drawline Cupboard
1000w x 500d x 850h



4D1000M

Double 4 Drawer Unit
1000w x 500d x 850h



SU620ML

LH Sink Unit
620w x 500d x 860h



SU1000M

Double Sink Unit
1000w x 500d x 860h



SU620MR

RH Sink Unit
620w x 500d x 860h

The **i classic** underbench furniture range is a robust furniture system with a plinth. The furniture sits on non marking nylon floor glides, to enable the unit to be moved easily.

i classic



2D500P

2 Drawer Unit
500w x 500d x 850h



SC500LP

LH Single Cupboard
500w x 500d x 850h



3D500P

3 Drawer Unit
500w x 500d x 850h



SC500RP

RH Single Cupboard
500w x 500d x 850h



4D500P

4 Drawer Unit
500w x 500d x 850h



3D1000P

Double 3 Drawer Unit
1000w x 500d x 850h



DRL500LP

LH Drawline Cupboard
500w x 500d x 850h



4D1000P

Double 4 Drawer Unit
1000w x 500d x 850h



DRL500RP

RH Drawline Cupboard
500w x 500d x 850h



DC1000P

Double Cupboard Unit
1000w x 500d x 850h



SU620PL

LH Sink Unit
620w x 500d x 860h



TR365LP

Tray Unit with LH Door
365w x 500d x 850h



SU620PR

RH Sink Unit
620w x 500d x 860h



TR365RP

Tray Unit with RH Door
365w x 500d x 850h



SU1000P

Double Sink Unit
1000w x 500d x 860h



TR706P

Double Tray Unit
706w x 500d x 850h



TR365OP

Open Tray Unit
365w x 480d x 850h



TR706OP

Double Open Tray Unit
706w x 480d x 850h

The **i static** underbench furniture range is a fixed furniture system. The furniture is non moveable and requires installation.

i static

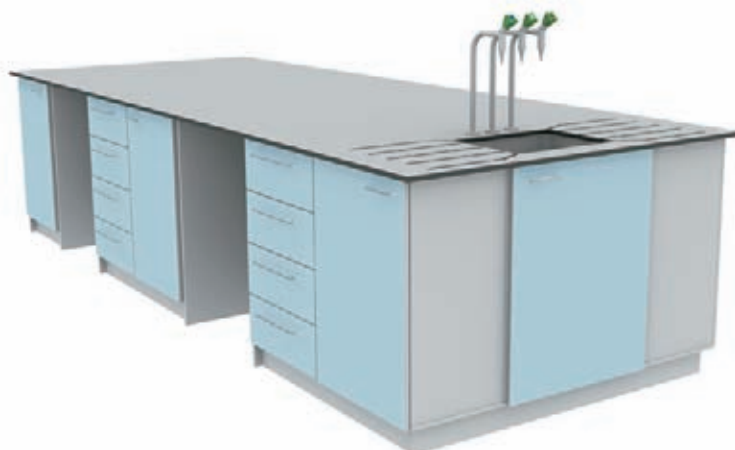

2D500F

2 Drawer Unit
500w x 550d x 914h



SC500RF

RH Single Cupboard
500w x 550d x 914h



3D500F

3 Drawer Unit
500w x 550d x 914h



TR359LF

Tray Unit with LH Door
359w x 550d x 914h



4D500F

4 Drawer Unit
500w x 550d x 914h



TR359RF

Tray Unit with RH Door
359w x 550d x 914h



DRL500LF

LH Drawline Cupboard
500w x 550d x 914h



TR359OF

Open Tray Unit
359w x 530d x 914h



DRL500RF

RH Drawline Cupboard
500w x 550d x 914h



3D1000F

Double 3 Drawer Unit
1000w x 550d x 914h



SC500LF

LH Single Cupboard
500w x 550d x 914h



DRL1000F

Double Drawline Unit
1000w x 550d x 914h



4D1000F

Double 4 Drawer Unit
1000w x 550d x 914h



SU1000F

Double Sink Unit
1000w x 550d x 914h



DC1000F

Double Cupboard Unit
1000w x 550d x 914h



SU620LF

LH Sink Unit
620w x 550d x 914h



TR700F

Double Tray Unit
700w x 550d x 914h



SU620RF

RH Sink Unit
620w x 550d x 914h



TR700OF

Open Double Tray Unit
700w x 530d x 914h



SU(3)144057F

Peninsular Sink Unit
1440w x 570d x 914h

The **i rail** underbench furniture range is a suspended furniture system that is mounted on rails below the worktop. An ideal solution for hospitals, clinics, infection control or wet room facilities

i rail



3D500S

3 Drawer Unit
500w x 500d x 550h



SC500LS

LH Single Cupboard
500w x 500d x 550h



DRL500LS

LH Drawline Cupboard
500w x 500d x 550h



SC500RS

RH Single Cupboard
500w x 500d x 550h



DRL500RS

RH Drawline Cupboard
500w x 500d x 550h



SU620LS

LH Single Cupboard
620w x 500d x 550h

End of peninsular sink units that can be used with all furniture ranges. The sink units sit on there own plinth and directly support the worktop.

peninsular sink units

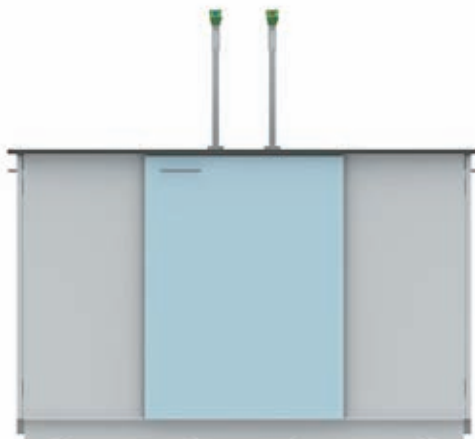

SU114057F

Peninsular Sink Unit
1140w x 570d x 914h



SU(2)144057F

Peninsular Sink Unit
1440w x 570d x 914h



SU144057F

Peninsular Sink Unit
1440w x 570d x 914h



SU(2)144072F

Peninsular Sink Unit
1440w x 720d x 914h



SU144072F

Peninsular Sink Unit
1440w x 720d x 914h



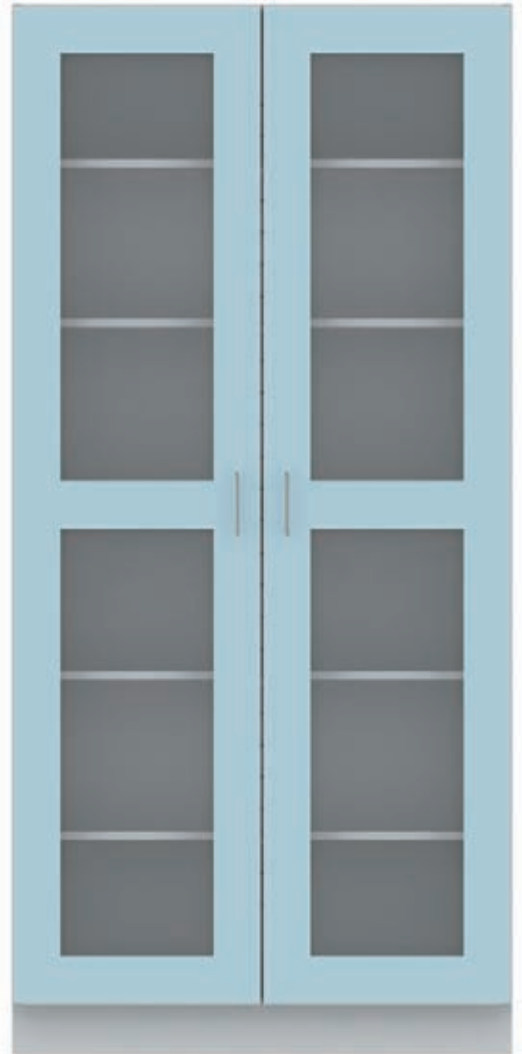

wall cupboards



WC1006

Wall Cupboard
1000w x 350d x 600h



WC5006R

RH Wall Cupboard
500w x 350d x 600h



WC1006G

Glass Wall Cupboard
1000w x 350d x 600h



WC5006RG

RH Glass Wall Cupboard
500w x 350d x 600h



WC1006GS

Glass Sliding
Wall Cupboard
1000w x 330d x 600h



WC3006L

LH Wall Cupboard
300w x 350d x 600h



WC5006L

LH Wall Cupboard
500w x 350d x 600h



WC3006LG

LH Glass Wall Cupboard
300w x 350d x 600h



WC5006LG

LH Glass Wall Cupboard
500w x 350d x 600h



WC3006R

RH Wall Cupboard
300w x 350d x 600h



WC5006GS

Glass Sliding
Wall Cupboard
500w x 330d x 600h



WC3006RG

RH Glass Wall Cupboard
300w x 350d x 600h

wall cupboards



WC1009
Wall Cupboard
1000w x 350d x 900h



WC5009R
RH Wall Cupboard
500w x 350d x 900h



WC1009G
Glass Wall Cupboard
1000w x 350d x 900h



WC5009RG
RH Glass Wall Cupboard
500w x 350d x 900h



WC1009GS
Glass Sliding
Wall Cupboard
1000w x 330d x 900h



WC3009L
LH Wall Cupboard
300w x 350d x 900h



WC5009L
LH Wall Cupboard
500w x 350d x 900h

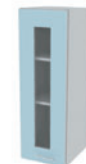

WC3009LG
LH Glass Wall Cupboard
300w x 350d x 900h



WC5009LG
LH Glass Wall Cupboard
500w x 350d x 900h



WC3009R
RH Wall Cupboard
300w x 350d x 900h



WC5009GS
Glass Sliding
Wall Cupboard
500w x 330d x 900h

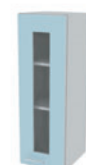

WC3009RG
RH Glass Wall Cupboard
300w x 350d x 900h

tall storage units



TS10035

Tall Storage Unit
1000w x 350d x 2100h



TS50035L

Tall Storage Unit LH
500w x 350d x 2100h



TS10035G

Glass Tall Storage Unit
1000w x 350d x 2100h



TS50035R

Tall Storage Unit RH
500w x 350d x 2100h



TS10052

Tall Storage Unit
1000w x 520d x 2100h



TS50052GL

Glass Tall Storage LH
500w x 520d x 2100h



TS10052G

Glass Tall Storage Unit
1000w x 520d x 2100h



TS50052GR

Glass Tall Storage RH
500w x 520d x 2100h



TS50035GL

Glass Tall Storage LH
500w x 350d x 2100h



TS50052L

Tall Storage Unit LH
500w x 520d x 2100h



TS50035GR

Glass Tall Storage RH
500w x 350d x 2100h



TS50052R

Tall storage Unit RH
500w x 520d x 2100h



Injury Prevention Stations, a melamine or tresa
constructed wall mounted casing with a wash
hand basin and hand operated shower.

ips stations



IPS1000

Low Level Station
900w x 145d x 1150h

Includes a removable
lid and one panel for
access to services.



IPS2000

High Level Station
850w x 175d x height to
suit ceiling

There are three
removable panels for
access to services.

An optional mirror can
also be mounted.

sinks and taps



sink detail options



INSET SINK

A sink with a flange is inserted into a cutout in the worktop.

The flange sits slightly proud of the worktop.



UNDERMOUNT SINK

A sink with a flat flange is fixed to the underside of the worktop, the cutout in the worktop has a 10mm overhang. This detail is ideal for recessed draining grooves and sink lids if required.



DROP IN SINK

A rebate is cut into the worktop, allowing a sink with a flat flange to be dropped into the rebate. The sink sits slightly below the worksurface. The rebate is finished with a chamfered detail. This detail is ideal for rebated draining grooves.



INSET SINK WITH DRAINER

Similar to a kitchen, an inset sink in stainless steel or epoxy resin is inserted into a cutout. The sink has its own drainer and anti drip edging.



SM8 undermount and inset sink

Epoxy Resin
Bowl size -
450 x 365 x 200 deep



SD915-DO inset sink with drainer

Epoxy Resin
Bowl size -
400 x 300 x 200 deep
O/a size 915 x 410



SS6 undermount and inset sink

Epoxy Resin
Bowl size -
350 x 300 x 200 deep



L11050 inset sink with drainer

316 grade Stainless Steel
Bowl size -
508 x 356 x 250 deep
O/a size 1030 x 500



SN9 drop in sink

Epoxy Resin
Bowl size -
406 x 305 x 203 deep



DD1500 sink top with drainer (for peninsular)

Epoxy Resin
Bowl size -
450 x 360 x 200 deep
O/a size 1500 x 750

Please note, these are our most commonly used sinks. Please call our technical team for our full range of sinks and drainers. If a special is required, please enquire as we can fabricate custom size stainless steel sinks.

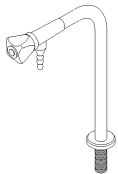

Water Fitting

Code No. 18 526.009
Bench fitting with detachable nozzle

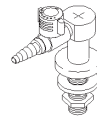

Gas Tap

Code No. 08 317.009
Bench fitting with 1 valve and a "Lift turn" safety handle



Special Water

Code No. 15 402.009
Bench fitting in plastic with 12mm PEX pipe, protected by a brass pipe.

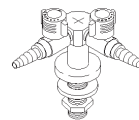

Gas Tap

Code No. 08 318.009
Bench fitting with 2 valves and "Lift turn" safety handles

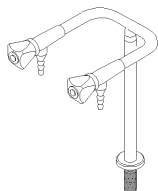

Water Fitting

Code No. 18 503.009
Bench fitting with 2 valves and detachable nozzles

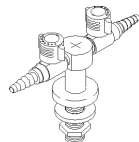

Gas Tap

Code No. 08 319.009
Bench fitting with 2 valves (180deg.) and "Lift turn" safety handles

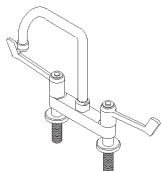

Water Fitting

Code No. 08 500.729
Mixer tap for bench mounting with swivel spout and detachable nozzle

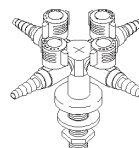

Gas Tap

Code No. 08 320.009
Bench fitting with 4 valves and "Lift turn" safety handles

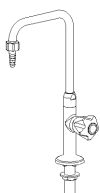

Water Fitting

Code No. 18 505.009
Bench fitting with 1 valve and detachable nozzle and swivel spout

➤ A selection of our most commonly used laboratory taps. Please call our technical team for more information on our complete range of taps.

mobile benches



mb1 mobile bench



The **mb1** mobile bench is a versatile movable laboratory bench. With a tresspa worktop and lockable castors. From the front the **mb1** has two furniture units which can be selected (see options) and an open shelf area. From the rear the **mb1** has an inset space allowing for the user to use a lab chair and work at the bench.

mb1

1500w x 750d x 930h
(dimensions are overall size)

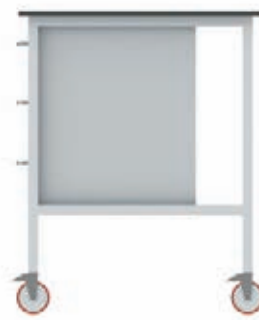

Options . . .

3 styles of units can be requested, drawline cupboard, 3 drawer and single cupboard with adjustable shelf. For clean rooms the **mb1** can also be manufactured with a stainless steel frame.

mb2 mobile bench



The **mb2** mobile bench is a versatile movable laboratory bench. With a tresa worktop and lockable castors. Below the worktop is a 300mm deep tresa shelf set 266mm from the floor height.

mb2

1500w / 1200mm / 1000mm x 750d x 930h
(dimensions are overall size)



Options ...

For clean rooms the **mb2** can also be manufactured with a stainless steel frame.

mb3 mobile bench



The **mb3** mobile bench is a versatile movable laboratory bench. With a tresspa worktop / upstand and lockable castors. From the front the **mb3** has two cupboard units, and an open shelf area. Above the worktop is a fixed melamine shelf.

mb3

1500w x 738d x 930h, Shelf -1400h
(dimensions are overall size)



Options . . .

For clean rooms the **mb3** can also be manufactured with a stainless steel frame.

mb4 mobile bench



The **mb4** mobile bench is a versatile movable laboratory bench. With a tresspa worktop and lockable castors.

mb4

1500w / 1200mm / 1000mm x 750d x 930h
(dimensions are overall size)



Options ...

For clean rooms the **mb4** can also be manufactured with a stainless steel frame.

fume cupboards



Ducted Fume Cupboards

Our range of ducted fume cupboards comply with the requirements and recommendations of BS EN 14175. The standard fume cupboards are available in 1200mm, 1500mm, 1800mm and 2000mm module widths. However, all bespoke sizes of external and internal widths, depths and heights can be easily manufactured with no large cost penalty.

The standard range has 45 degree angled side mullions each 150mm in width to accommodate the mechanical and electrical services. Alternative mullion profiles ranging from 40mm to 120mm in width are also available.



➤ Call our [technical team](#) to discuss your exact requirements

Features

- Attractive design, with an aerodynamic zintec mild steel outer carcass with an epoxy polyester powder coated gloss finish.
- Stainless steel front sill – hinged option available.
- Air by-pass via louvred aluminium grilles available.
- Infill panelling by extended continuous side panels can be provided with front panel supported on gas struts for easy access for maintenance.
- Internal chamber and baffles constructed from Trespa as standard, with options for PVC, polypropylene, 316 grade stainless steel, toughened glass or cast epoxy resin.
- Smooth toughened glass vertical sliding sash with fail-safe mechanism on single weight system – option for sashes can be combination style with horizontal sliding windows available.
- Auto-resetting sash lock.
- Worktops manufactured from cast epoxy resin and dished – options for Ceramic, Trespa, PVC, polypropylene and 316 grade stainless steel available.
- Range of wet and dry services plumbed in rigid copper or flexible pipe work.
- Range of polypropylene, cast epoxy and stainless steel drip cups, sinks and vulcathene bottle traps.
- Range of switch socket outlets, RCD protection, data outlets are available.
- Twin fluorescent light fittings and light switches fitted as standard.
- Programmable controls panels to meet EN14175 fitted as standard incorporating sash high alarms, low airflow alarms and fan stop/start facility.
- Ventilated storage cupboards – suitable for acids, solvents or flammables.
- PVC ductwork connection pieces with integral volume control dampers fitted as standard.
- Adaptable for use as on a constant air volume or variable air volume extract system.
- Scaffold bosses and framework can be fitted.
- Pass through ports between inner and outer skins can be provided.
- Fire suppression systems can be provided.
- Tissue guards/paper restrictors to back baffles can be provided.

fume cupboards

Recirculating Fume Cupboards

Our range of recirculation fume cupboards comply with the requirements and recommendations of BS 7989 : 2001.

The units are available in a range of standard widths 1200mm, 1500mm, 1800mm and 2000mm. The standard range has 45 degree angled side mullions each 150mm in width to accommodate the mechanical and electrical services. Alternative mullion profiles ranging from 40mm to 120mm in width are also available. The units are fitted above the soffit with pre-filters (to remove particulates before the main filter), carbon filters (to absorb chemical vapours) and centrifugal fan units to re-circulate air back into the laboratory.

The quantity of filters and fans required are dependent on the size of the fume cupboard. The filters are changed through the top hinged access door which is supported on gas struts. The extract volume is controlled by speed controllers so when the sash is closed the air volume reduces, thus reducing the noise level and preventing high face velocities when the sash is closed.



➤ Call our [technical team](#) to discuss your exact requirements

Features

- Attractive design, with an aerodynamic zintec mild steel outer carcass with an epoxy polyester powder coated gloss finish.
- Stainless steel front sill – hinged option available.
- Air by-pass via louvred aluminium grilles available.
- Infill panelling by extended continuous side panels can be provided with front panel supported on gas struts for easy access for maintenance.
- Internal chamber and baffles constructed from Trespa as standard, with options for PVC, polypropylene, 316 grade stainless steel, toughened glass or cast epoxy resin.
- Smooth toughened glass vertical sliding sash with failsafe mechanism on single weight system – option for sashes can be combination style with horizontal sliding windows available.
- Auto-resetting sash lock.
- Worktops manufactured from cast epoxy resin and dished – options for Ceramic, Trespa, PVC, polypropylene and 316 grade stainless steel available.
- Range of wet and dry services plumbed in rigid copper or flexible pipework.
- Range of polypropylene, cast epoxy and stainless steel drip cups, sinks and vulcathene bottle traps.
- Range of switch socket outlets, RCD protection, data outlets, etc., available.
- Twin fluorescent light fittings and light switches fitted as standard.
- Programmable controls panels to meet EN14175 fitted as standard incorporating sash high alarms, low airflow alarms and fan stop/start facility.
- Ventilated storage cupboards – suitable for acids, solvents or flammables.
- PVC ductwork connection pieces with integral volume control dampers fitted as standard.
- Adaptable for use as on a constant air volume or variable air volume extract system.
- Scaffold bosses and framework can be fitted.
- Pass through ports between inner and outer skins can be provided.
- Fire suppression systems can be provided.
- Tissue guards/paper restrictors to back baffles can be provided.

Walk-in Fume Cupboards

Our range of walk-in fume cupboards comply with the applicable requirements and recommendations of BS EN 14175.

The standard fume cupboards are in available 1200mm, 1500mm, 1800mm and 2000mm module widths. However, all bespoke sizes of external and internal widths, depths and heights can be easily manufactured with no large cost penalty.

The standard range has 45 degree angled side mullions each 150mm in width to accommodate the mechanical and electrical services. Alternative mullion profiles ranging from 100mm to 120mm in width are also available.



➤ Call our [technical team](#) to discuss your exact requirements

Features

- Attractive design, with an aerodynamic Zintec mild steel outer carcass with an epoxy polyester powder coated gloss finish.
- Air by-pass via louvred aluminium grilles available.
- Infill panelling by extended continuous side panels can be provided with front panel supported on gas struts for easy access for maintenance.
- Internal chamber and baffles constructed from Trespa as standard, with options for PVC, polypropylene, 316 grade stainless steel, toughened glass or cast epoxy resin.
- Two independent toughened glass vertical sliding sashes with fail-safe mechanism on single weight system – option for sashes can be combination style with horizontal sliding windows available.
- Floor level and intermediate removable worktops manufactured from cast epoxy resin and dished, other options available are: Ceramic, Trespa, PVC, polypropylene and 316 grade stainless steel.
- Range of wet and dry services plumbed in rigid copper or flexible pipe work.
- Range of wall mounted and recessed polypropylene drip cups and vulcathene bottle traps.
- Range of switch socket outlets, RCD protection and data outlets are available.
- Twin fluorescent light fittings and light switches fitted as standard – low level lights available as an option.
- Programmable controls panels to meet EN14175 fitted as standard incorporating low airflow alarms and fan stop/start facility.
- PVC ductwork connection pieces with integral volume control dampers fitted as standard.
- Adaptable for use as on a constant air volume or variable air volume extract system.
- Scaffold bosses and framework can be fitted.
- Pass through ports between inner and outer skins can be provided.
- Fire suppression systems can be provided.
- Tissue guards/paper restrictors to back baffles can be provided.

fume cupboards

Water Wash Fume Cupboards

Our range of water wash fume cupboards comply where applicable with the requirements and recommendations of BS EN 14175. The units are generally installed in situations either Perchloric acid or Hydrofluoric acid is used and the extracted air needs to be scrubbed prior to discharge to atmosphere.

The units are available in a range of standard widths of 1200mm, 1500mm, 1800mm and 2000mm. The standard range has 45 degree angled side mullions each 150mm in width to accommodate the mechanical and electrical services. Alternative mullion profiles ranging from 40mm to 120mm in width are also available.



> Call our [technical team](#) to discuss your exact requirements

Features

- The system is of the water re-circulatory type for greater water efficiency – option for mains fed available.
- Internal chamber and water wash body constructed from PVC as standard, with option for polypropylene.
- Within the main water wash body at the rear of the fume cupboard would be a bank of spray pipe work and nozzles complete with sump and drain assembly.
- Re-circulation equipment (pump, tank, pipe work and valves) are fitted within support frame with the re-circulation tank is mounted on a PVC spillage tray.
- The front of the support frame would be provided with hinged and lockable false doors.
- A polypropylene knitmesh moisture eliminator pad, within a PVC casing designed to remove any airborne water droplets is fitted above the fume cupboard.
- Above the demister section would be fitted a back wash water spray nozzle which would be manually operated, independent of the re-circulation system.
- Attractive design, with an aerodynamic zintec mild steel outer carcass with an epoxy polyester powder coated gloss finish.
- Stainless steel front sill – hinged option available.
- Air by-pass via louvred aluminium grilles available.
- Infill panelling by extended continuous side panels can be provided with front panel supported on gas struts for easy access for maintenance.
- Smooth toughened glass vertical sliding sash with fail-safe mechanism on single weight system – option for poly carbonate sash.
- Auto-resetting sash lock.
- Worktops manufactured from PVC and dished – options for polypropylene and cast epoxy resin available.
- Range of wet and dry services plumbed in rigid copper or flexible pipe work.
- Range of polypropylene drip cups, sinks and vulcathene bottle traps.
- Range of switch socket outlets, RCD protection, data outlets are available.
- Twin fluorescent light fittings and light switches fitted as standard.
- Programmable controls panels to meet EN14175 fitted as standard incorporating sash high alarms, low airflow alarms and fan stop/start facility.
- Tissue guards/paper restrictors to back baffles can be provided.

Radioactive Fume Cupboards

Our range of radioactive fume cupboards comply with the applicable requirements and recommendations of BS EN 14175.

The standard fume cupboards are available 1200mm, 1500mm, 1800mm and 2000mm module widths. However, all bespoke sizes of external and internal widths, depths and heights can be easily manufactured with no large cost penalty.

The standard range has 45 degree angled side mullions each 150mm in width to accommodate the mechanical and electrical services. Alternative mullion profiles ranging from 40mm to 120mm in width are also available.



➤ Call our [technical team](#) to discuss your exact requirements

Features

- Internal chamber sides, back, soffit and worktop manufactured from fully welded 316 grade stainless steel and polished to provide a seamless monolithic chamber suitable for radioactive use.
- Attractive design, with an aerodynamic zintec mild steel outer carcass with an epoxy polyester powder coated gloss finish.
- Mounted onto a fully welded mild steel box section support framework powder coated to match the fume cupboard carcass.
- Stainless steel front sill – hinged option available.
- Air by-pass via louvred aluminium grilles available.
- Infill panelling by extended continuous side panels can be provided with front panel supported on gas struts for easy access for maintenance.
- Smooth toughened glass vertical sliding sash with fail-safe mechanism on single weight system – option for sashes can be combination style with horizontal sliding windows available.
- Auto-resetting sash lock.
- Range of wet and dry services plumbed in rigid copper or flexible pipe work.
- Range of stainless steel drip cups and sinks.
- Range of switch socket outlets, RCD protection, data outlets are available.
- Twin fluorescent light fittings and light switches fitted as standard.
- Programmable controls panels to meet EN14175 fitted as standard incorporating sash high alarms, low airflow alarms and fan stop/start facility.
- Ventilated storage cupboards – suitable for acids, solvents or flammables.
- PVC ductwork connection pieces with integral volume control dampers fitted as standard.
- Adaptable for use as on a constant air volume or variable air volume extract system.
- Scaffold bosses and framework can be fitted.
- Pass through ports between inner and outer skins can be provided.
- Fire suppression systems can be provided.
- Tissue guards/paper restrictors to back baffles can be provided.

fume cupboards

Fume Extract Systems

We are able to design and install fume extraction systems serving our fume cupboards and ventilated enclosures to ensure that all our installations perform efficiently, safely and with minimum noise levels.

All PVC ductwork is fabricated in accordance with DW154 and installations comply with the recommendation of BS EN 14175.

A range of centrifugal and direct driven fan units are available, which are fabricated from polypropylene. The fan motors used are available in either single or three phases and can be single speed, two speed or inverter driven.

We are able to undertake a full turnkey installation, including the supply and installation of all electrical equipment to control and operate the extract systems, e.g, isolators, fan starters, interconnecting wiring, etc.

Where materials used are required by the client to be fire retardant, we can design and install systems from either fire retardant polypropylene or from PVC with a glass reinforced plastic outer coating. Special items, such as fire dampers, intumescent fire collars, attenuators, HEPA filter housings etc are also available.



finishes





Standard Sheet Sizes
2550mm x 1860mm,
3050mm x 1530mm.
Panel thickness
16mm



The colours and patterns in this document are printed and therefore may vary slightly from actual product colours. Samples are available on request. Trespa, Trespa Athlon and Trespa TopLab are trademarks or registered trademarks of Trespa International B.V. or its subsidiaries in United Kingdom and / or their countries.

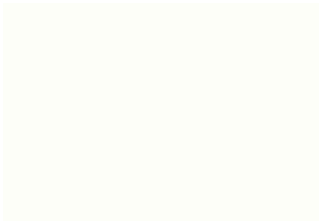

White
E0-00

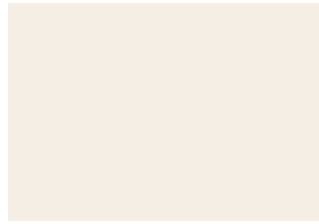

Pastel Grey
E0-015



Silver Grey
E0-02



Sand
E3-01

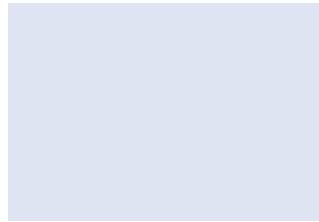

Icely Blue
E25-01

Standard Sheet Sizes

2550mm x 1860mm,
3050mm x 1530mm.

Panel thickness

16mm

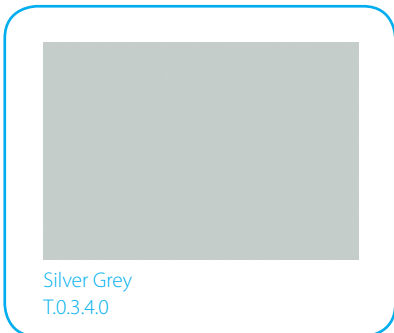
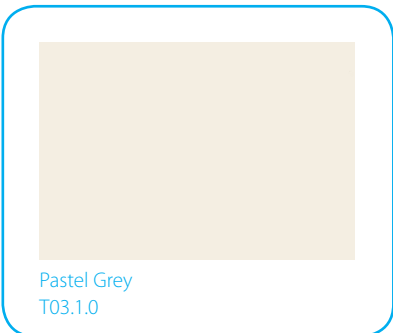
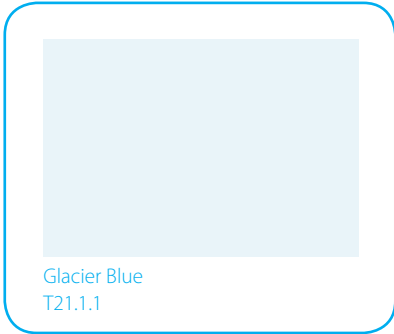
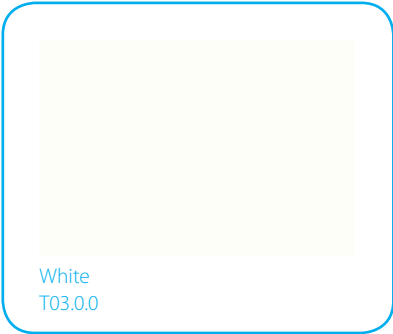

Standard Sheet Sizes
2550mm x 1860mm,
3050mm x 1530mm.

Panel thickness
16mm

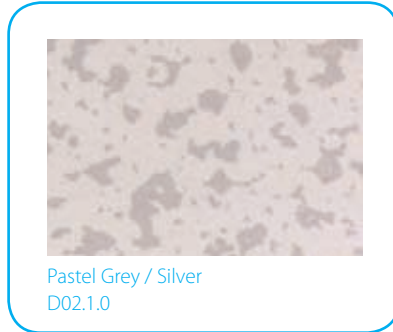

The colours and patterns in this document are printed and therefore may vary slightly from actual product colours. Samples are available on request. Trespa, Trespa Athlon and Trespa TopLab are trademarks or registered trademarks of Trespa International B.V. or its subsidiaries in United Kingdom and / or their countries.

Laboratory Type	Main Requirement	Product
Biological and Clinical	<p>High Stain Resistance In Biological and Clinical areas, benchtops need to have a high stain resistance as well as being easy to decontaminate. Trespa TopLab^{PLUS} meets these requirements.</p>	Trespa TopLab ^{PLUS}
	<p>Radio-Labelled Compounds The cross-linked surface of Trespa TopLab^{PLUS} benchtops makes it impermeable to radio-labelled compounds.</p>	Trespa TopLab ^{PLUS}
	<p>Hygienic The smooth surface finishes of both Trespa TopLab^{PLUS} and Trespa Athlon do not support the growth of bacteria or fungi. Micro-organisms cannot penetrate the surface or the core and risk of contamination is low. Trespa TopLab^{PLUS} or Trespa Athlon benchtops are easy to keep clean.</p>	Trespa TopLab ^{PLUS} Athlon
	<p>Easy to Disinfect The large size of the Trespa TopLab^{PLUS} and Trespa Athlon panels reduces the number of joints necessary, making them ideal for sterile work areas.</p>	Trespa TopLab ^{PLUS} Athlon

Laboratory Type	Main Requirement	Product
Chemical	<p>Chemical Resistance Trespa TopLab^{PLUS} is designed to resist the most aggressive chemicals such as organic solvents, caustic agents, acids and bases. Spills of most chemicals, solvents or detergents will not damage the surface of Trespa TopLab^{PLUS}, or leave stains if they are removed within 24hrs.</p>	Trespa TopLab ^{PLUS}
	<p>Heat Resistance Trespa TopLab^{PLUS} can be used in situations where the surface is exposed to temperatures (dry heat) up to 140°C continuously and 180-200°C for up to 20 minutes, without any detrimental effect or change in appearance. Being a thermoset material it will not lose its mechanical strength under these circumstances.</p>	Trespa TopLab ^{PLUS}
	<p>Impact Resistance The optimal combinations of modulus of elasticity, tensile strength and flexural strength makes Trespa Athlon panels very resilient and therefore highly impact resistant.</p>	Athlon

Laboratory Type	Main Requirement	Product
Physical / Educational	<p>Abrasion & Scratch Resistance Trespa Athlon's decorative surface is impregnated with melamine resin (one of the hardest resins known). This makes it extremely scratch resistant and therefore suitable for applications involving heavy appliances such as ovens, chromatographs, televisions and computer equipment.</p>	Athlon
	<p>Heat Resistance A Trespa Athlon benchtop will retain all its characteristics in temperatures ranging from -40°C to +180°C.</p>	Athlon

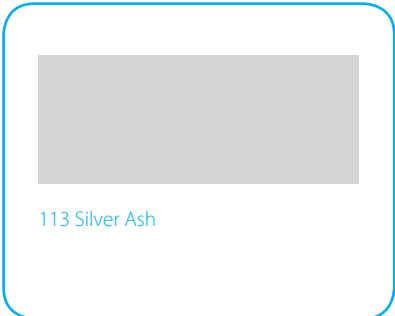
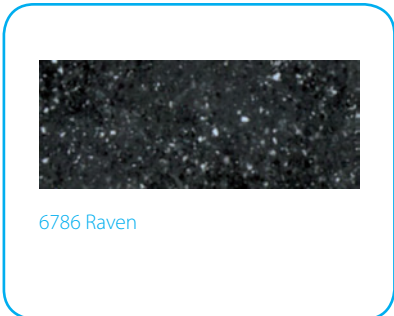
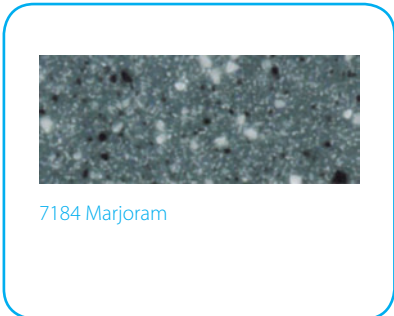
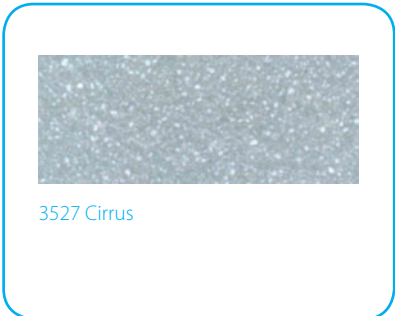

Velstone solid surfacing material is nonporous and provides a sterile surface.

Other advantages are:
 Hygienic, Seamless
 Ease of Cleaning, Design Flexibility
 Choice of Finish, Fire Retardant
 Ease of Fabrication, Installation
 Curved Surfaces, 10 Year Warranty

The colours and patterns in this document are printed and therefore may vary slightly from actual product colours. Samples are available on request. Velstone is a trademark or registered trademark of Velstone Ltd or its subsidiaries in the United Kingdom and / or other countries.

Solid Wood Worktops

Iroko and similar hardwoods have been the traditional choice for school laboratory classrooms and chemistry and physics labs. The main advantage of using Iroko worktops is that they can easily be refurbished by sanding the top layer. The Durable surface has resistance against attacks from acids, solvents and heat.

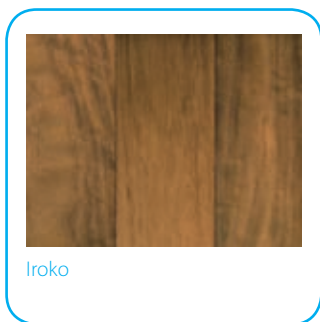

Laminate Worktops and Door Fronts

Value for money worktop & door material for general usage including food preparation areas, sink runs and around hobs and cookers. Can accurately mimic other worktop materials, including granite, slate and wood, so will suit modern and traditional schemes. Resistant to most stains and chemicals, but not to heat or steam. Not suitable as a cutting surface. For greater durability we would recommend a high pressure solid laminate worktop such as Trespa Athlon or similar.

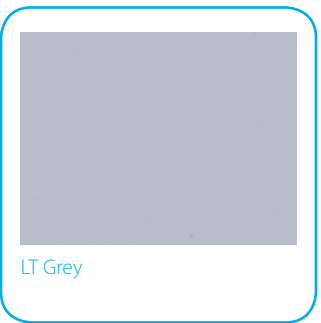
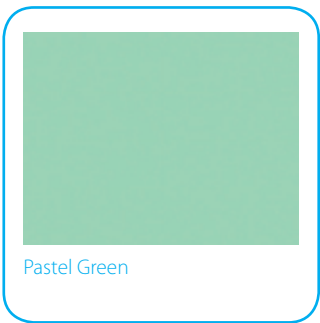
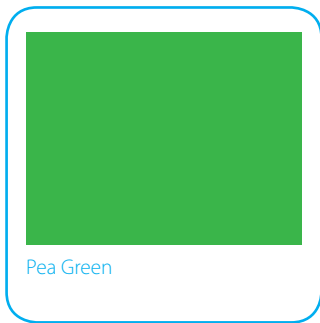
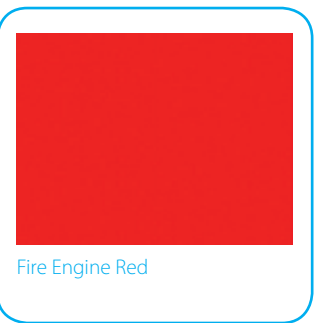
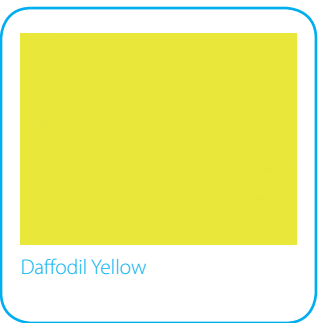
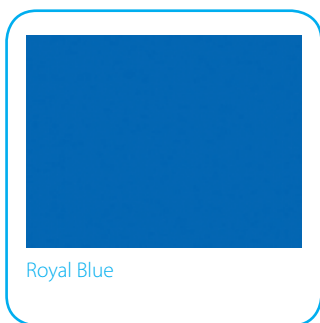

These are just some of the most popular laminates colours taken from a much wider range of colours and wood effect finishes..

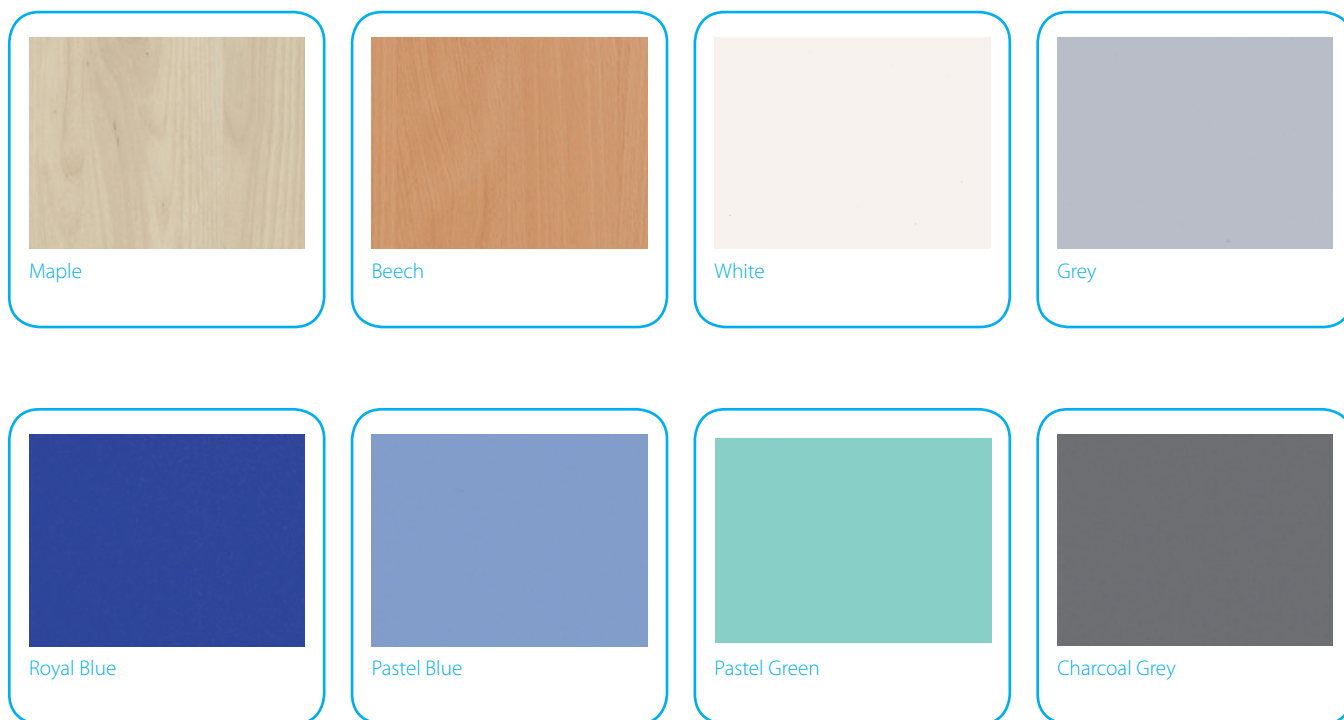

Melamine Panels

25 mm Panels are suitable for use as work tops.

18 mm Panels are suitable for carcass panels and doors.

Please note some colours are not available in both 25 and 18 mm variants.,

Other colours are available to special order, these may require additional lead time when compared with our stocked colour range.

Our [technical team](#) will be pleased to advice on current availability and options.

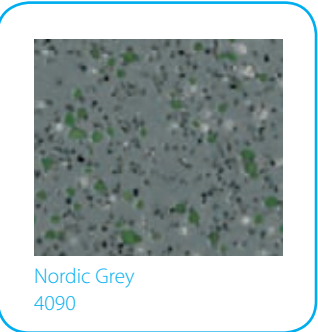
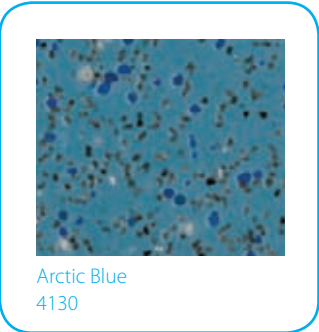
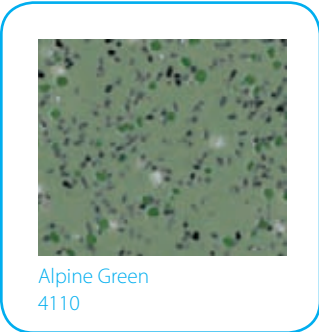
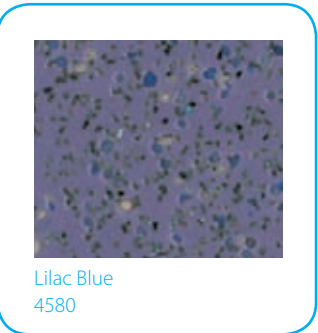
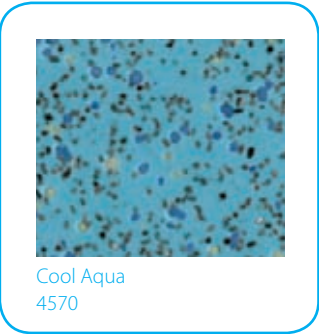

The colours and patterns in this document are printed and therefore may vary slightly from actual product colours. Samples are available on request. PolyFlor, PolyFlor XL & PolySafe are trademarks or registered trademarks of PolyFlor Limited or its subsidiaries in United Kingdom and / or other countries.



Black Panther
8640



Polar Grey
9340



Graphite
9120



Slate Grey
9200



Mushroom
9110



Desert Sand
9180



Oatmeal
9240



Eau de Nil
9080



Conifer
9220

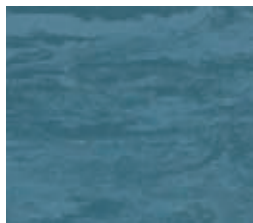

Atlantic Blue
9170



Venetian Blue
9040

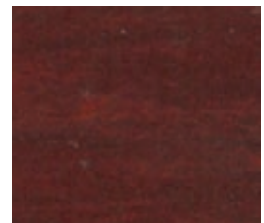

Black Cherry
8580



Sea Green
9190



Nougat
9010



Red Cedar
9300



Dove White
8740

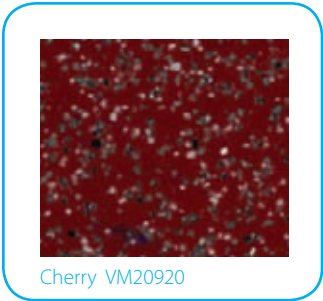
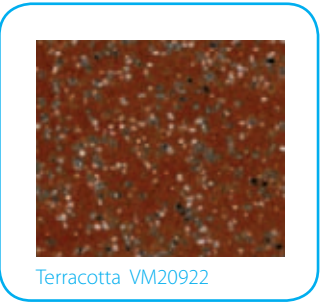
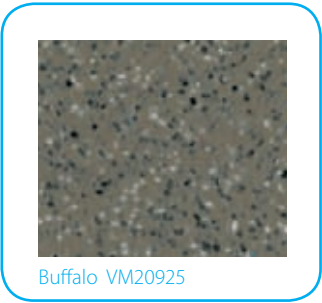
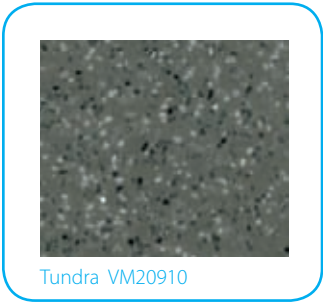
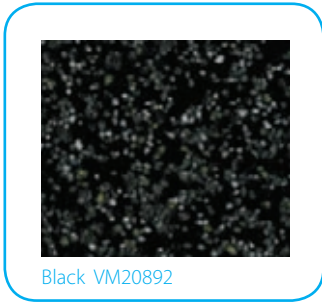
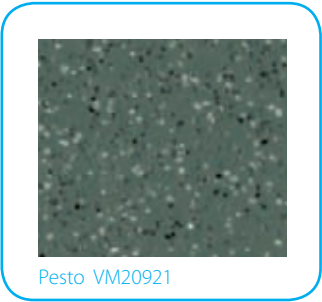
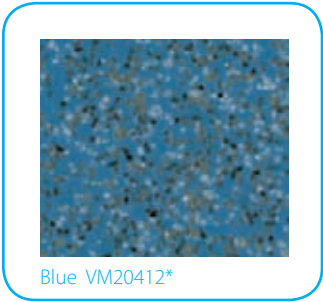
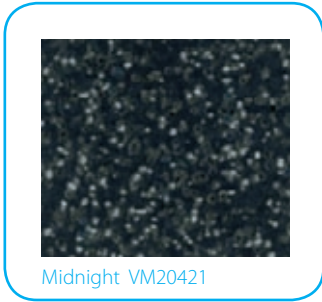
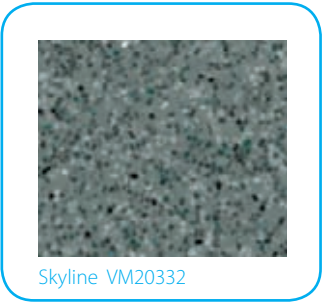
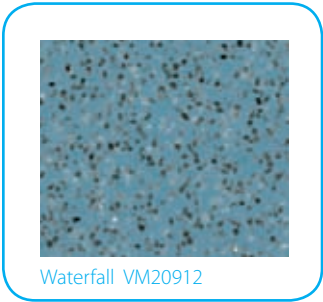
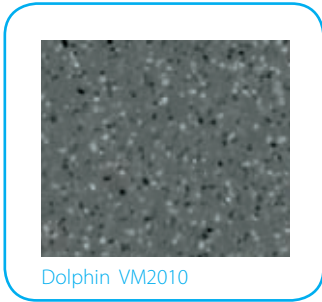
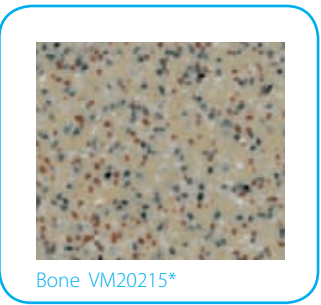
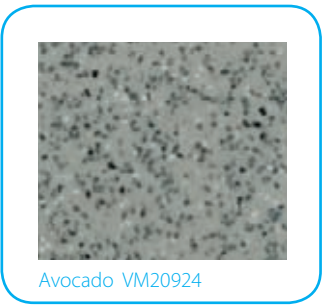
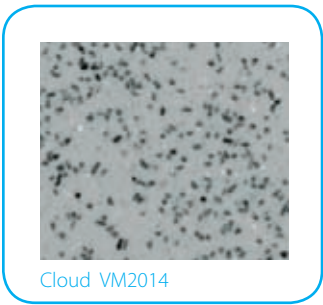
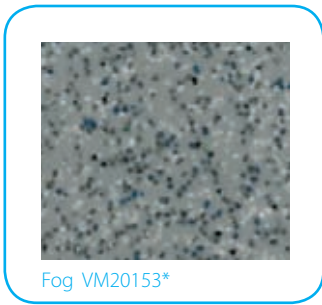

The colours and patterns in this document are printed and therefore may vary slightly from actual product colours. Samples are available on request. Altro and Altro Walkway are trademarks or registered trademarks of Altro Limited or its subsidiaries in United Kingdom and / or other countries.

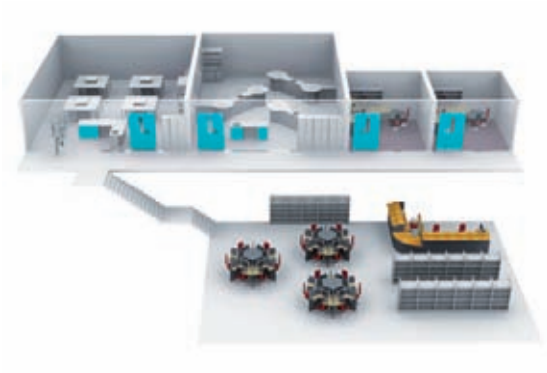

Case Study Industrial Laboratory Facility

Supply and installation of specially designed Laboratory Furniture. The manufacture and installation of the furniture involved the plinths of the furniture being laid as a separate item, to enable the flooring to be covered up the plinth, thus ensuring a completed sealed floor.

Following installation of the flooring, the base units were then attached to the pre-laid plinths and the velstone work surfaces were then installed..

The use of velstone enabled the client to have completely joint free work surfaces, which in this instance was of paramount importance.



case studies



Velstone worktops were used extensively throughout these laboratory facilities as the client required all work surfaces to be joint free.



Case Study Rockwood Pigments Industrial Laboratory Facility

A complete turnkey industrial installation
The project was the result of extremely bad flood damage, the client was under pressure to return its existing damaged facility back to an operational QC, Analytical, and Research laboratories. We produced detailed design and layout plans and an extensive programme of works to ensure minimum disruption to the running of the clients existing manufacturing facility.

On a rolling programme, the existing flood damaged fixtures and fittings were removed, and the relevant Mechanical and Electrical services made safe.

Each laboratory area consisted of the following scope of works:

- Wall partitions stripped and made good, and replaced where necessary.
- New Suspended ceiling and lighting were installed.
- The complete area re-decorated.
- Existing floors were stripped, re-levelled, and ceramic tiles installed.
- New Laboratory Furniture, Fume Cupboards and extraction arms were manufactured and installed.
- All new Mechanical & Electrical services.
- Completely new air conditioning and make up air systems were installed.

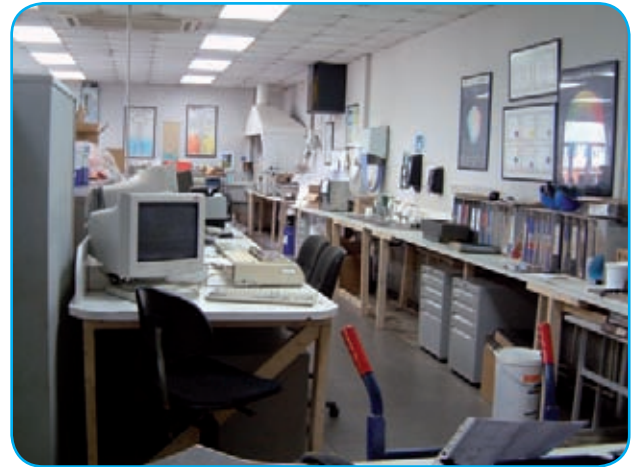

case studies



Trespa worktops were used throughout this laboratory, in addition specialist extraction arms were also installed to the laboratory benches.



Case Study Department of Chemistry Cambridge University

Supply and installation of specially designed Laboratory Furniture and Designated Write Up Area.

The furniture was installed, with the underbench cupboards and drawer units supporting IROKO work surfaces.

In the write up areas the furniture and shelving was manufactured using a beech effect melamine MDF.

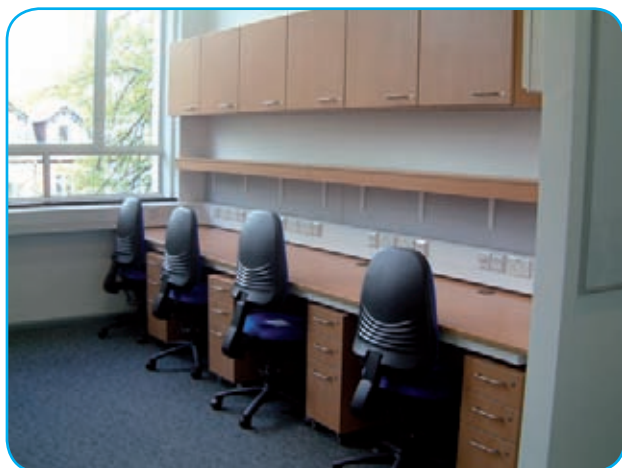

case studies



IROKO solid wood worktops were selected for use in these laboratories partly for aesthetics and also because hard woods offer a good work surface that is ideal for chemistry laboratories.



Case Study Cambridge University Department of Pathology Teaching Room

Supply and installation of Teaching Room Furniture
The project included the initial design, manufacture and installation of furniture, sinks, taps, and electrical pods.

The brief was to provide a robust teaching environment for student teaching, with ample services and storage, whilst retaining the aesthetics of a modern teaching environment.

The Trespa worktops were supported on a cantilever frame system with suspended cupboards, specially built to house individual student microscopes. In this instance cupboard doors were also produced in Trespa.



case studies



Bespoke [Trespa](#) service pods were built to house water and electric's for the bench runs.

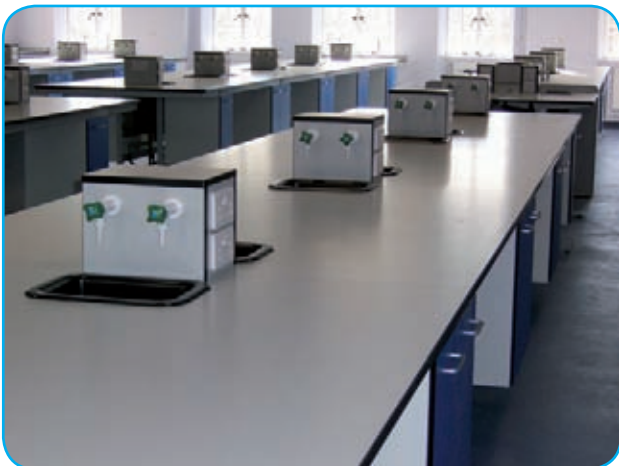

Case Study Industrial R&D laboratory

A complete turnkey refurbishment of an existing R&D facility for a large industrial company.

The scope of works included:

- Full bespoke design service
- Manufacture of furniture
- Manufacture & Installation of Trespa work surfaces throughout.
- Fume extraction design and installation
- Fume cupboard supply, install & commission
- Flooring and decorating
- Complete M&E works



case studies



Pastel colours were chosen to take full advantage of the natural light and give a clean and soft looking working environment, white Trespa with its black core was used to give additional contrast.



Case Study Cambridge University Research Laboratory

InterFocus were appointed the laboratory furniture manufacturer and installer by the building contractor for the project.

InterFocus supplied and installed all the laboratory furniture, IPS Stations, and additional fixtures and fittings.



case studies



Bespoke [IPS stations](#) were manufactured and installed to match the furniture colour scheme. Broen valves emergency showers and eye wash units were used throughout.



Case Study

A complete turnkey project for a leading food, and water testing company, based in North London.

This project was a complete Design & Build Project, of an industrial type building of approximately 8000 sq feet.

The project comprised:

- Initial Client Feasibility Study and budget estimates.
- Liaison with Council Building Control on behalf of the client.
- CDM & Project Management.
- Supply and installation of Fresh Air and Air Conditioning System.
- Installation of Suspended ceiling and lighting
- Installation of Mezzanine Floor.
- Installation of Vinyl Flooring
- Installation of Temperature Controlled Rooms.
- Installation of Autoclaves & Washers
- Installation of Fume Cupboards and Extraction System.
- Installation of Partitions to create individual laboratory areas.
- Manufacture & Installation of Office Furniture.
- Manufacture and Installation of Laboratory Furniture
- Installation of Alarm and Security System
- Installation of all Mechanical & Electrical Services.

From concept to completion in 20 weeks.



case studies



This project was a complete [turnkey](#) package, including installation of a mezzanine floor.

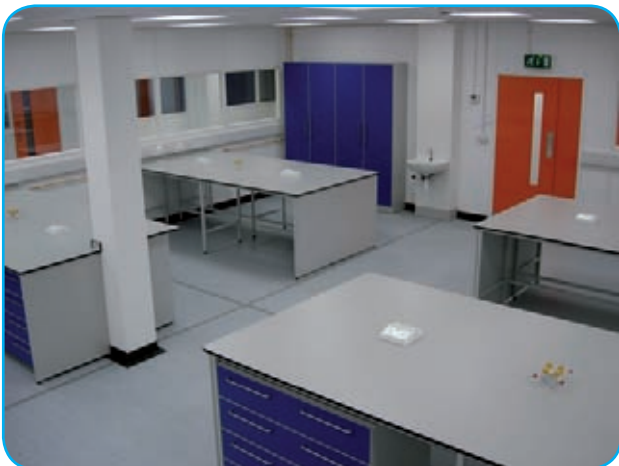

Case Study Dunn Nutrition Research Laboratories, Write up areas and library.

A design, manufacture and installation contract for MRC Dunn Human Nutrition. This project comprised of building works to incorporate an existing laboratory and library area into a Larger laboratory Facility, write up area and lecture theatre.

The scope of works comprised of:

- Removal of existing walls, furniture and services.
- Construction of new walls.
- Installation of new ceilings and lighting
- Installation of Flooring. Vinyl & Carpet.
- Installation of Fume Cupboards and Extraction Systems.
- Installation of Air Conditioning Systems.
- Installation of purpose made Solid Maple Lecture Theatre Furniture.
- Manufacture & Installation of Laboratory Furniture
- Manufacture and Installation of Write Up Office Furniture
- Installation of all Mechanical and Electrical Services.



case studies



This project was a complete **turnkey** package, which included the erection of new internal walls and rerouting of existing M&E services alongside the installation of new M&E services and air handling equipment.

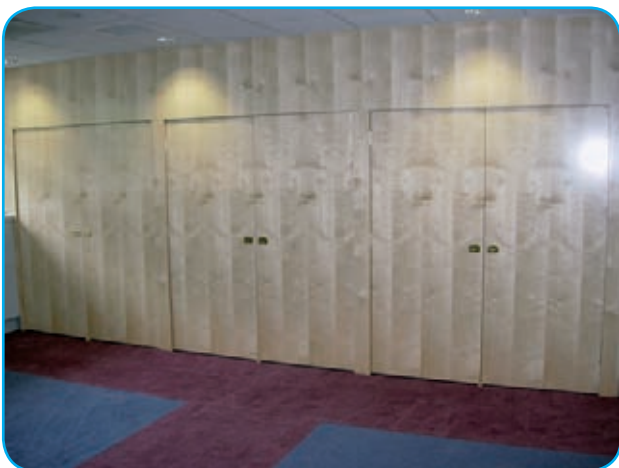

contact us

- Call a member of our technical team on [01223 894833](tel:01223894833) for any queries you have on our products and they will be happy to answer any of your questions.



Pentagon Business Park, Cambridge Road, Linton, Cambridge, CB21 4NN

Tel: 01223 894833 • Fax: 01223 894235 • Email: contact@interfocuseurope.com • Web: www.mynewlab.com



 **InterFocus**



InterFocus Ltd

Cambridge Road

Linton

Cambridge

Cambridgeshire

CB21 4NN

Tel: 01223 894833 • Fax 01223 894235

Email: contact@interfocuseurope.com

www.mynewlab.com