



AUTOFLEX

METAL MEMBRANE COUPLINGS



AUTOFLEX METAL MEMBRANE

Contents & Coupling Application Configurations

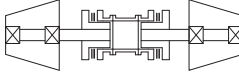
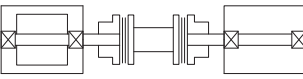
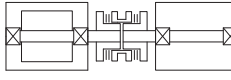
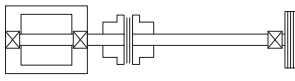
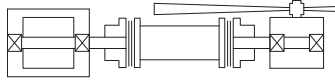
Coupling Type	Typical Application		Series	Page No
	Introduction - Metal Membrane Configuration Coupling Selection Service Factors			2 3 & 4
High Performance Turbo - Compressor Couplings	High Performance Couplings are designed to the highest specifications. These couplings are designed using state of the art finite element analysis. The couplings have been optimised for high speed and high torque duties.		HP - RM HP - RZ HP - MS	5
Spacer Couplings. Double Flex (Two Metal Membranes packs)	Spacer Couplings utilising two metal membrane packs will accommodate angular, axial and offset misalignment. The driving and driven shaft ends are separated allowing for installation and maintenance without moving the connected equipment. These couplings are offered both in API* and non-API configurations.		ED ES CD ECS HRII HFTII	6 7 & 8 9 10 & 11 12 13
Close Coupled Double Flex (Two Metal Membranes packs)	Close Coupled Couplings utilising two metal membrane packs will accommodate angular, axial and offset misalignment. The driving and driven shaft separations tend to be very close (e.g. 3mm).		CCA CCR	14 & 15 16 & 17
Single Flex (One Metal Membrane packs)	Single Flex Couplings are capable of accommodating angular and axial misalignments which are commonly found in three bearing applications such as fans, blowers and sprocket drive pulleys. Single Flex couplings cannot accommodate offset misalignments.		EB CB	18 & 19 20
Cooling Tower Couplings Double Flex (Two Metal Membranes packs)	Cooling Tower Couplings utilise two metal membrane packs, which will accommodate angular, axial and offset misalignment. Shaft separations are generally long and thus the coupling is supplied with a carbon fibre composite spacer tube.		CT ES CT ECS	21 22
Faxback Form	Information for the Selection of Autoflex Couplings.			23

* API - American Petroleum Institute

The specifications contained within this brochure are correct at the time of going to print. Autogard is continually reviewing and upgrading the specifications on all its product range and therefore reserve the right to change any details.

AUTOFLEX METAL MEMBRANE COUPLINGS

The Autoflex Metal Membrane Coupling is designed to provide a highly reliable connection for rotating equipment. The coupling requires no lubrication and thus is maintenance free. Properly installed, the coupling is designed to provide infinite life.

Autoflex Advantages

Metal membrane coupling construction provides optimum power and misalignment capability

Cartridge transmission unit provides for easy assembly while maintaining an inherent balance to AGMA class 9.

The Autoflex has an optional design to handle non-standard DBSE* using factory assembled Guard Ring Packs which are bolted to a standard spacer tube.

Membranes are made from high strength 301 stainless steel.

Hubs have been optimised to provide a larger bore capacity.

All steel parts are phosphate coated.

ATEX Approval

The range of Autoflex Couplings has been approved under ATEX directive 94/9/EC - for use in potentially explosive gas and dust atmospheres.

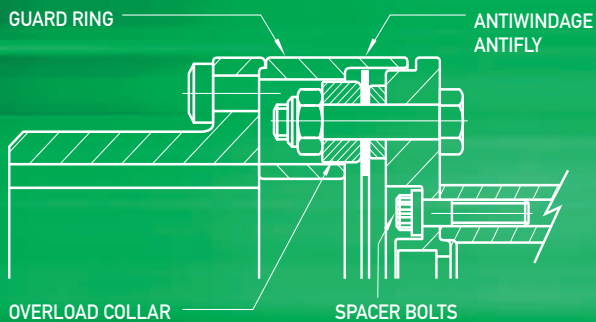
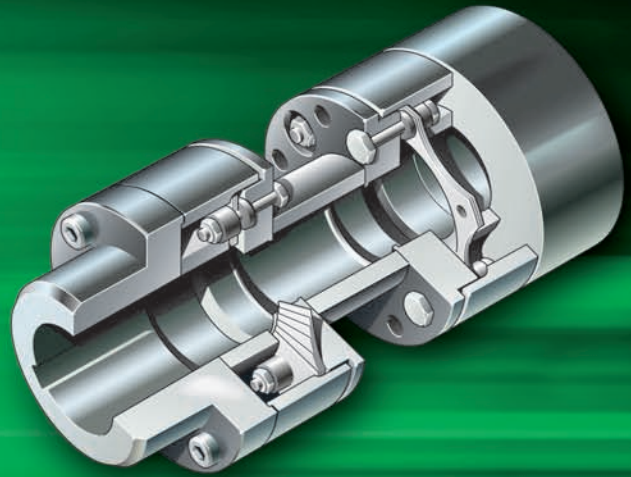

Reduced windage configuration which also provides an inherent fail-safe feature in the unlikely event of membrane failure.

Overload collars also provide an inherent fail-safe feature, protecting the membrane in the event of severe transient torque overloads.

Coupling performance is enhanced using high grade washers with an optimised radius profile.

Higher grades of dynamic balance are possible through the elimination of balance tools. Gaggling is achieved by locking the guard ring to the spacer flange.

The Autoflex membrane has been optimised using finite element analysis. This has resulted in a waisted link design which provides more flexibility and thus substantially lower reaction forces on the bearing of the connected equipment. The stresses through the new membrane design are uniform and are inherently low due to the reduced weight and inertia of the pack. The membranes have been designed to provide for infinite life utilising a safety factor of 2 times on the Modified Goodman Diagram.

*DBSE - Distance Between Shaft Ends



AUTOFLEX METAL MEMBRANE COUPLINGS



Coupling Selection

Method

Data required for Coupling Selection.







- Application details (for service factor)
- Power and rpm of the driver
- Shaft details of the driving and driven equipment

- (1) Determine the service factor (SF) from the application and classification lists noted below.
- (2) Calculate the maximum kW/1000 rpm rating:

$$\text{kW}/1000\text{rpm} = (\text{kW} \times 1000 \times \text{SF}) / \text{rpm}$$
 Select the coupling which has a higher max rating.
- (3) Check the Limiting Conditions:
 - a Check the hub bore capacity is suitable
 - b Check the speed capability and specify whether the coupling requires balancing.
 - c Check coupling dimensions such as DBSE*, Overall Length and Outside Diameter.

*DBSE - Distance Between Shaft Ends

Service Factors - SF

Load Characteristics	Electric Motor, Steam Turbine Gas Turbine	Steam Engine, Water Turbine, 8 Cyl. Recip. Engine	6 Cyl. Recip. Engine	4 Cyl. Recip. Engine
 Constant Torque eg. Centrifugal pumps, compressors & blowers, light duty agitators and fans.	1.0	1.5	2.0	2.5
 Slight Fluctuations eg. Slurry pumps, Screw compressors, Lobe and Vane Blowers.	1.5	2.0	2.5	3.0
 Moderate Fluctuations and/or Slight Shock Loads Double acting pumps, Recip. Comp.	2.0	2.5	3.0	3.5
 Large Fluctuations and/or Moderate Shock Loads 1 or 2 Cylinder Recip.pumps.	2.5	3.0	3.5	4.0
 Shock Loads or Light Torque Reversals Slitters, Rod Mill, Hot Mill	3.0	3.5	4.0	Consult Factory
 Heavy Shock Loads or Large Torque Reversals Feed Rolls, Reversing Mills	Consult Factory	Consult Factory	Consult Factory	Consult Factory

- (1) Use a minimum Service Factor of 1.25 when driving through a gearbox or using a direct on-line electric motor, and 1.5 when selecting a Cooling Tower Coupling.
- (2) Consult Autogard when using a Reciprocating Engine of less than 4 cylinders.
- (3) Service Factors provided are for reference only. Customer experience may dictate the selection of different Service Factors.

Membrane Configurations

The standard Flexible Membrane Pack is available in four, six and eight link designs to meet various torque, speed and misalignment conditions.

4 Link Membrane Pack

Four link membrane pack designs offer maximum misalignment and are ideal for low torque applications in which the reaction forces on the bearings must be kept to a minimum.

6 Link Membrane Pack

Six link membrane pack designs offer the optimum torque carrying capacity and flexibility making it the preferred choice for the standard Autoflex coupling product range.

8 Link Membrane Pack

Eight link membrane pack designs offer high torque carrying capacity suited for motor or generator drives with high peak torque and lower misalignment requirements.

Example

Driver: Water Turbine (75 kW at 1500 rpm)

Driven equipment: Screw Compressor

Turbine Bore: 60mm Compressor Bore: 50mm.

Distance Between Shaft Ends: (DBSE): 140mm

Service Factor for the Water Turbine & Screw Compressor: SF=2

$$\text{kW}/1000\text{rpm} = (75\text{kW} \times 1000 \times 2) / 1500$$

$$\text{kW}/1000\text{rpm} = 100$$

Coupling selection based on the maximum rating - ES 130-6

Coupling Bore Capacity: 70mm

Maximum speed for the ES 130-6 is 7100 rpm Unbalanced

Minimum Allowable DBSE: 73mm (Solid Spacer)

Ordering Example

Series	Size	Links	DBSE (where applicable)
ES	130	6	140

AUTOFLEX HIGH PERFORMANCE COUPLINGS

Autogard has been manufacturing Metal Membrane Couplings for over 30 years. The Autogard High Performance Coupling is designed to provide a safe and reliable coupling connection for high speed turbo machinery. The coupling has been designed using state of the art finite element analysis to ensure optimum performance.

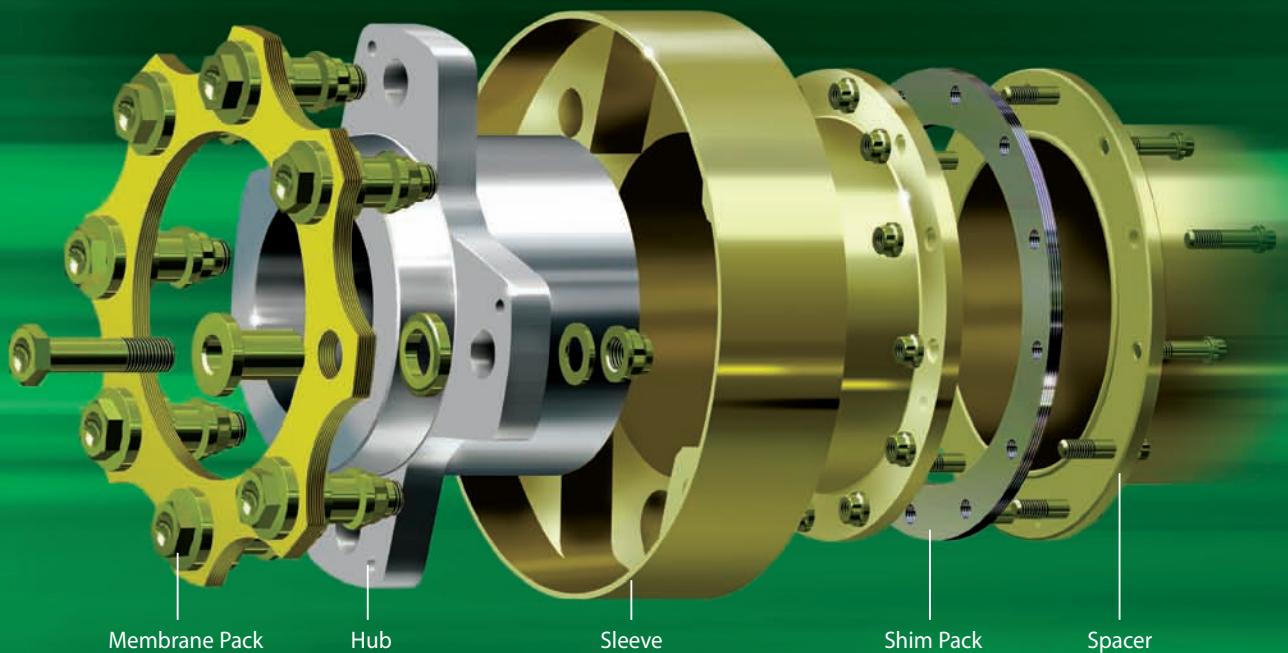
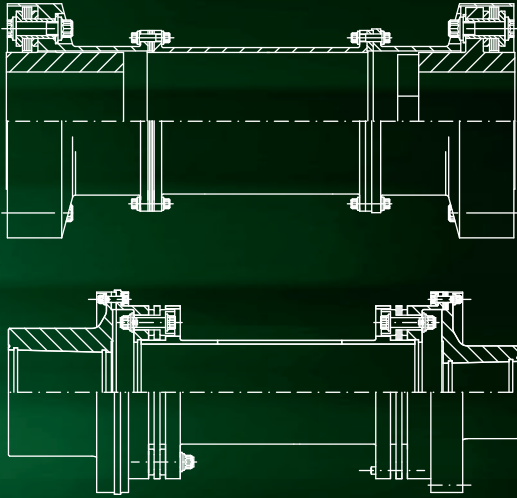

Features and benefits

- Reduced moment configurations
- Never requires lubrication
- Coated membranes for maximum life
- Compliance with API 671
- Inherent fail-safe design
- Unitised Membrane Pack assembly
- Improved balance and reliability
- Reduce windage configurations
- Proven waisted link membrane design
- Minimised weights and interias
- Torque measuring can be incorporated
- Speeds up to 30,000rpm, from the standard range

High Performance Duties:

- Compressor Drives
- Generator Sets
- Booster Pumps
- Main Oil Line Pumps
- Test Dynamometers
- Test Rigs
- Boiler Feed Pumps
- Turbine Drives
- Any critical application requiring a safe and reliable coupling manufactured and balanced to the highest specifications

Please refer to Autoflex High Performance Couplings catalogue for the selection and full technical & dimensional details. Autoflex HP Couplings are made under licence from FlexElement™ Texas Inc.

AUTOFLEX SERIES HVII

TYPE ED COUPLINGS (DOUBLE FLEX - SHORT SPACER)

The Autoflex ED & ES couplings have been designed for medium and high duty applications. The coupling has been designed with the minimal number of parts and therefore provides an economical solution for applications requiring a spacer coupling.

The ES coupling is offered with four, six and eight link membranes. The four and six link couplings have been optimised for medium duty application. The eight-link design offers higher torque capacities within a given diameter. ED couplings have 6-link membranes as standard.

The couplings are manufactured to tight tolerances ensuring a high degree of dynamic balance. The couplings have been designed to meet AGMA class 9 as manufactured and can be balanced to meet the AGMA class 10 or API 610 8th Edition requirements.

The coupling consists of five parts, two hubs, two membrane packs and one spacer. The couplings use waisted link membranes which provide higher flexibility and ensures lower reaction forces on the driving and driven equipment. The six and eight-link couplings also utilise overload collars which protect them from high transient torques providing trouble free operation.

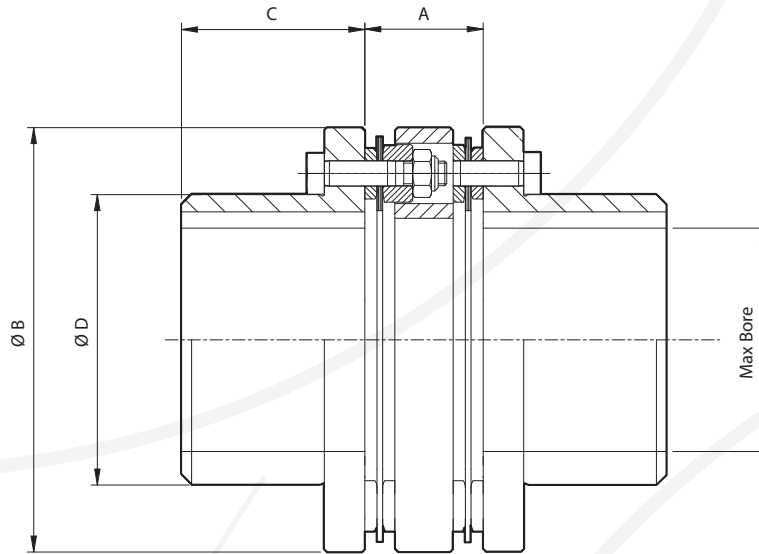

**ED - 6 Link
Short Spacer Coupling**

Technical Details

Coupling Size - Links	Rating kW/1000 rpm	Torque Rating		Maximum Speed ②		① Weight (kg)	① Inertia (kgm ²)
		Cont. (Nm)	Peak (Nm)	Unbal. (rpm)	Bal. (rpm)		
15 - 6	16	150	270	10,600	24,000	1.7	0.0018
35 - 6	37	350	620	8,900	19,000	3.6	0.0058
70 - 6	73	700	1,240	8,000	16,000	5.6	0.0134
150 - 6	157	1,500	2,680	6,500	12,000	14.0	0.0504
330 - 6	346	3,300	6,600	5,900	10,000	21.5	0.119
480 - 6	502	4,800	9,600	5,400	9,100	29.7	0.208

1) Weight and Inertias are calculated using maximum bored standard hubs and minimum DBSE.

2) Maximum Unbalanced Speeds are based on AGMA 9000-C90 Class 9 with min DBSE and max interference bored coupling hubs.

Dimensional Details

Coupling Size - Links	① Maximum Bore (mm)	A		B (mm)	C (mm)	D (mm)	Misalignment ③	
		Min DBSE (mm)	Max DBSE (mm)				Axial (mm)	Parallel (mm)
15 - 6	40	30.5	48.0	89	36.5	53.0	0.76	0.20
35 - 6	50	37.1	58.0	110	46.0	70.6	0.97	0.24
70 - 6	66	37.1	58.0	133	57.5	91.0	1.12	0.24
150 - 6	75	46.5	66.5	170	74.6	123	1.47	0.33
330 - 6	98	61.7	94.0	205	90.0	134	1.79	0.44
480 - 6	110	73.0	109	230	95.0	150	2.02	0.50

3) Maximum Parallel Offset is based on a minimum DBSE (1/2 Deg. Angular misalignment per membrane pack).

4) Maximum Bore assumes an interference fit with a rectangular key.

NOTE: The ED Coupling is used on 4 bearing systems, such as motor to pump / gearbox when short DBSEs are required.

AUTOFLEX SERIES HVII

TYPE ES COUPLINGS (DOUBLE FLEX - SPACER)

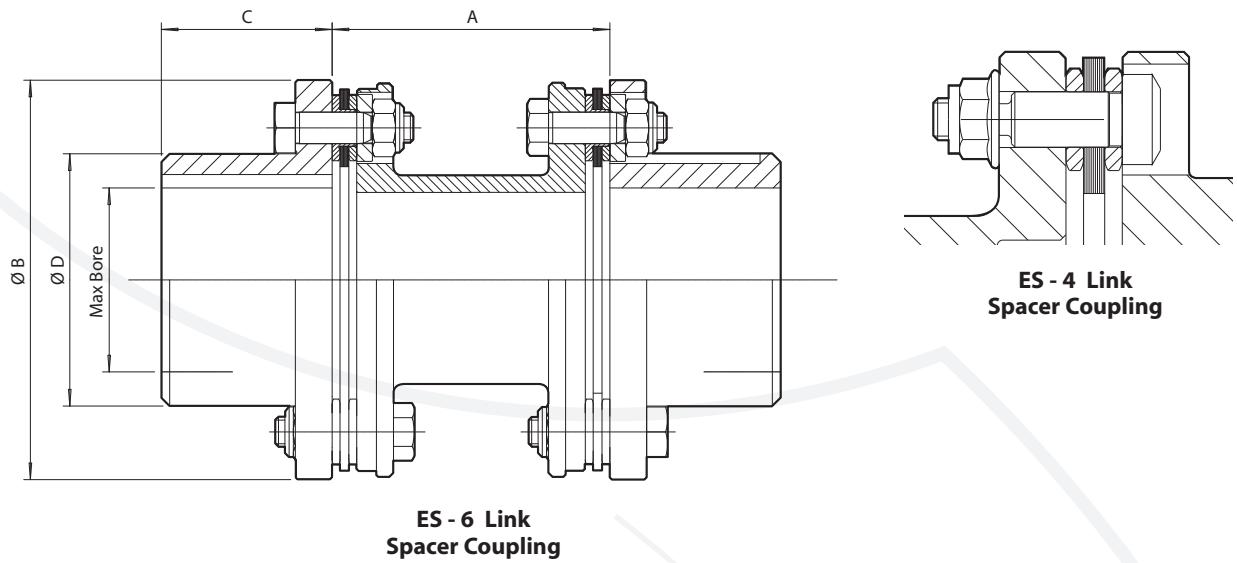

Technical Details

Coupling Size - Links	Rating kW/100 rpm	Torque Rating		Maximum Speed ②		① Weight (kg)	Weight per m of extra DBSE (kg/m)	① Inertia (kgm ²)	Inertia per m of extra DBSE (kgm ² /m)
		Cont. (Nm)	Peak (Nm)	Unbal. (rpm)	Bal. (rpm)				
11 - 4	12	110	220	10,500	21,000	1.72	5.60	0.0017	0.0029
19 - 4	20	190	380	9,200	19,000	3.05	7.25	0.0042	0.0046
15 - 6	16	150	270	10,200	24,000	1.98	4.61	0.0019	0.0015
35 - 6	37	350	620	8,500	19,000	4.22	6.56	0.0065	0.0045
70 - 6	73	700	1,240	7,700	16,000	6.64	13.4	0.015	0.016
130 - 6	136	1,300	2,600	7,100	14,000	9.57	11.5	0.028	0.015
150 - 6	157	1,500	2,680	6,300	12,000	15.6	27.9	0.055	0.063
220 - 6	230	2,200	4,400	6,300	12,000	15.6	17.8	0.063	0.037
330 - 6	346	3,300	6,600	5,700	10,000	23.9	23.2	0.13	0.057
480 - 6	502	4,800	9,600	5,300	9,100	33.1	31.0	0.22	0.10
700 - 6	733	7,000	14,000	5,000	8,200	44.4	30.7	0.38	0.16
880 - 6	921	8,800	17,600	4,700	7,400	58.7	30.9	0.61	0.19
1300 - 6	1,360	13,000	26,000	4,300	6,500	84.9	41.2	1.2	0.32

1) Weight and Inertias are calculated using maximum bored standard hubs and minimum DBSE.

2) Maximum Unbalanced Speeds are based on AGMA 9000-C90 Class 9 with min DBSE and max interference bored coupling hubs.

Dimensional Details

Coupling Size - Links	④ Maximum Bore (mm)	⑤ Min DBSE (mm)	B (mm)	C (mm)	D (mm)	③ Misalignment	
						Axial (mm)	Parallel (mm)
11 - 4	40	45	88.9	33.3	56.6	1.50	0.7
19 - 4	48	56	103.3	39.6	67	1.90	0.9
15 - 6	40	48	89	36.5	53	0.76	0.34
35 - 6	50	58	110	46.0	70.6	0.97	0.44
70 - 6	66	58	133	57.5	91	1.12	0.44
130 - 6	70	73	152	65.0	96	1.33	0.49
150 - 6	90	64	170	74.6	123	1.47	0.46
220 - 6	83	81	180	75.0	114	1.57	0.56
330 - 6	98	94	205	90.0	134	1.79	0.65
480 - 6	110	109	230	95.0	150	2.02	0.72
700 - 6	123	118	257	110	169	2.29	0.79
880 - 6	137	128	282	120	188	2.49	0.90
1300 - 6	160	143	325	130	218	2.89	0.95

3) Maximum Parallel Offset is based on a minimum DBSE (1/2 Deg. Angular misalignment per membrane pack).

4) Maximum Bore assumes an interference fit with a rectangular key.

5) Most sizes stocked with 100mm and 140mm DBSEs.

6) Bolted tube spacers available.

Note: The ES Coupling is used on 4 bearing systems, such as motor to pump / gearbox where economical non API spacer couplings are required.

AUTOFLEX SERIES HVII

TYPE ES COUPLINGS (DOUBLE FLEX - SPACER)

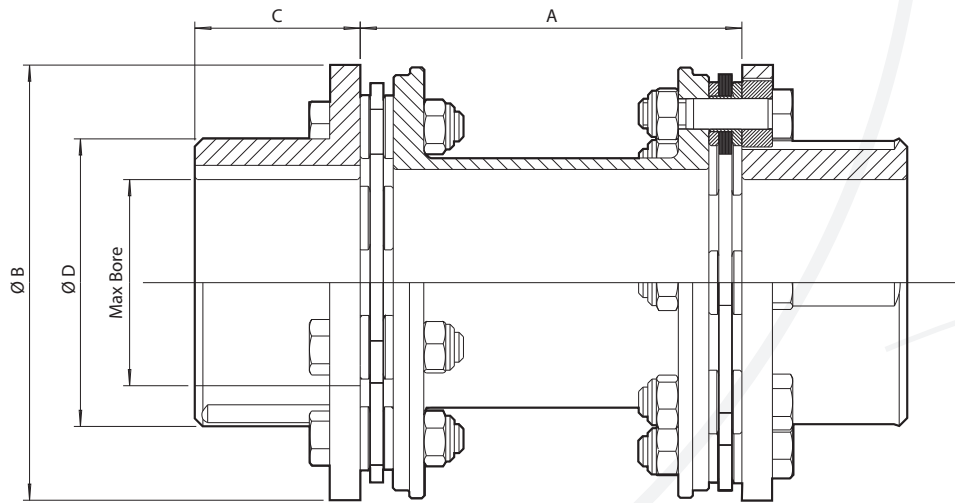

**ES - 8 Link
Spacer Coupling**

Technical Details

Coupling Size - Links	Rating kW/1000 rpm	Torque Rating		Maximum Speed ②		① Weight (kg)	Weight per m of extra DBSE (kg/m)	① Inertia (kgm ²)	Inertia per m of extra DBSE (kgm ² /m)
		Cont. (Nm)	Peak (Nm)	Unbal. (rpm)	Bal. (rpm)				
340 - 8	353	3,400	6,800	6400	12800	14.3	10.4	0.054	0.0228
510 - 8	537	5,100	10,200	5800	11300	22.0	13.4	0.108	0.0391
740 - 8	778	7,400	14,800	5400	10000	31.3	16.8	0.196	0.0643
1040 - 8	1,086	10,400	20,800	5000	9000	43.4	21.8	0.334	0.100
1410 - 8	1,481	14,100	28,200	4700	8200	57.7	26.2	0.543	0.150
1900 - 8	1,989	19,000	38,000	4400	7500	75.4	32.7	0.851	0.223
2500 - 8	2,618	25,000	50,000	4100	7200	98.5	43.2	1.24	0.303
2870 - 8	3,001	28,700	57,400	3900	6400	121	40.8	1.86	0.382
3590 - 8	3,757	35,900	71,800	3700	6000	150	48.9	2.64	0.527
4420 - 8	4,631	44,200	88,400	3600	5600	186	55.0	3.72	0.679
7240 - 8	7,585	72,400	144,800	3200	4700	304	73.9	8.45	1.36
11660 - 8	12,205	116,600	233,200	2900	4000	468	104.9	17.7	2.58
20000 - 8	20,944	200,000	400,000	2500	3400	815	150.7	43.3	5.13

1) Weight and Inertias are calculated using maximum bored standard hubs and minimum DBSE.

2) Maximum Unbalanced Speeds are based on AGMA 9000-C90 Class 9 with min DBSE and max interference bored coupling hubs.

Dimensional Details

Coupling Size - Links	④ Maximum Bore (mm)	A Min DBSE (mm)	B (mm)	C (mm)	D (mm)	Misalignment ③	
						Axial (mm)	Parallel (mm)
340 - 8	81	78	171	65	113	3.4	0.34
510 - 8	91	89	195	80	128	3.9	0.39
740 - 8	104	100	219	90	145	4.4	0.43
1040 - 8	115	112	243	100	161	4.9	0.49
1410 - 8	126	121	268	105	177	5.4	0.53
1900 - 8	139	130	293	115	194	5.9	0.57
2500 - 8	144	146	310	130	201	6.1	0.65
2870 - 8	164	146	344	145	230	6.9	0.64
3590 - 8	174	161	368	155	243	7.4	0.71
4420 - 8	188	169	393	175	263	7.9	0.74
7240 - 8	223	193	464	215	312	9.4	0.85
11660 - 8	258	226	538	235	361	11.0	1.0
20000 - 8	305	270	640	300	427	13.1	1.2

3) Maximum Parallel Offset is based on a minimum DBSE (1/3 Deg. Angular misalignment per membrane pack).

4) Maximum Bore assumes an interference fit with a rectangular key.

AUTOFLEX SERIES HVII

TYPE CD & ECS COUPLINGS (DOUBLE FLEX - SPACER)

The Autoflex CD & ECS is a drop out spacer style coupling designed to meet API 610 8th Edition for industrial pump couplings. The coupling consists of three parts, two shaft hubs and a factory pre-assembled transmission unit.

Unlike conventional membrane couplings, the anti-fly guard is designed to extend over the top of the membrane pack. This feature provides several benefits:

- Reduces the windage produced by the membrane pack.
- Acts as a coupling guard providing additional safety.
- Increases the retaining strength over conventional couplings.
- Eliminates the need for balancing tools (gag sleeves and bolts) and therefore increases the accuracy of the dynamic balance of the coupling.

The transmission unit is spigoted between the shaft hubs providing excellent balance characteristics. The coupling has been designed to provide an AGMA class 9 balance as manufactured. The coupling can be balanced up to an AGMA 11 for high speed, sensitive applications. The fact that the coupling does not require lubrication ensures that the balance will not degrade over the life of the driving and driven equipment.

The CD has been designed for very short DBSE applications. The ECS four and six link couplings are used in medium duty application providing a good combination of torque carrying and misalignment capacity.

The ECS eight-link coupling is used for high power applications.

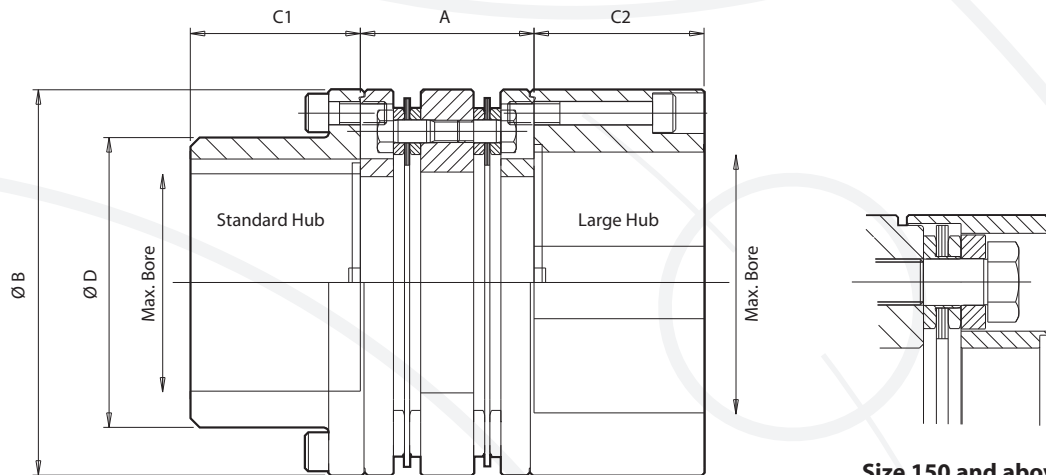

**CD - 6 Link
Short Spacer Coupling**

**Size 150 and above
have anti-fly guard rings**

Technical Details

Coupling Size - Links	Rating kW/1000 rpm	Torque Rating		Maximum Speed ②		① Weight (kg)	① Inertia (kgm ²)	Misalignment ③	
		Cont. (Nm)	Peak (Nm)	Unbal. (rpm)	Bal. (rpm)			Axial (mm)	Parallel (mm)
15 - 6	16	150	270	9,800	24,000	2.33	0.00259	0.76	0.20
35 - 6	37	350	620	8,300	19,000	4.68	0.00810	0.97	0.24
70 - 6	73	700	1,240	7,600	16,000	7.18	0.0186	1.12	0.24
150 - 6	157	1,500	2,680	6,200	12,000	16.8	0.0731	1.47	0.33
330 - 6	346	3,300	6,600	5,300	10,000	34.4	0.219	1.79	0.44
480 - 6	502	4,800	9,600	4,900	9,100	47.3	0.373	2.02	0.50

1) Weight and Inertias are calculated using maximum bored standard hubs and minimum DBSE.

2) Maximum Unbalanced Speeds are based on AGMA 9000-C90 Class 9 with min DBSE and max interference bored coupling hubs.

3) Maximum Parallel Offset is based on a minimum DBSE (1/2 Deg. Angular misalignment per membrane pack).

Dimensional Details

Coupling Size - Links	Maximum Bore ④		A (DBSE)		B (mm)	C1 (mm)	C2 (mm)	D (mm)
	Std. Hub (mm)	Large Hub (mm)	Min (mm)	Max (mm)				
15 - 6	45	60	48.5	80.0	89	36.5	36.5	60
35 - 6	55	74	59.9	100	110	46.0	46.0	75
70 - 6	75	90	59.9	100	133	58.7	58.7	100
150 - 6	95	112	90.7	110	170	74.5	74.5	130
330 - 6	120	140	128	152	205	90.0	90.0	163
480 - 6	130	-	143	169	230	95.0	-	181

4) Maximum Bore assumes an interference fit with a rectangular key.

NOTE: The CD coupling is used on 4 bearing systems such as motor to pump / gearbox when short DBSEs and Drop Out Transmission Units are required

AUTOFLEX SERIES HVII

TYPE ECS COUPLINGS (DOUBLE FLEX - SPACER)

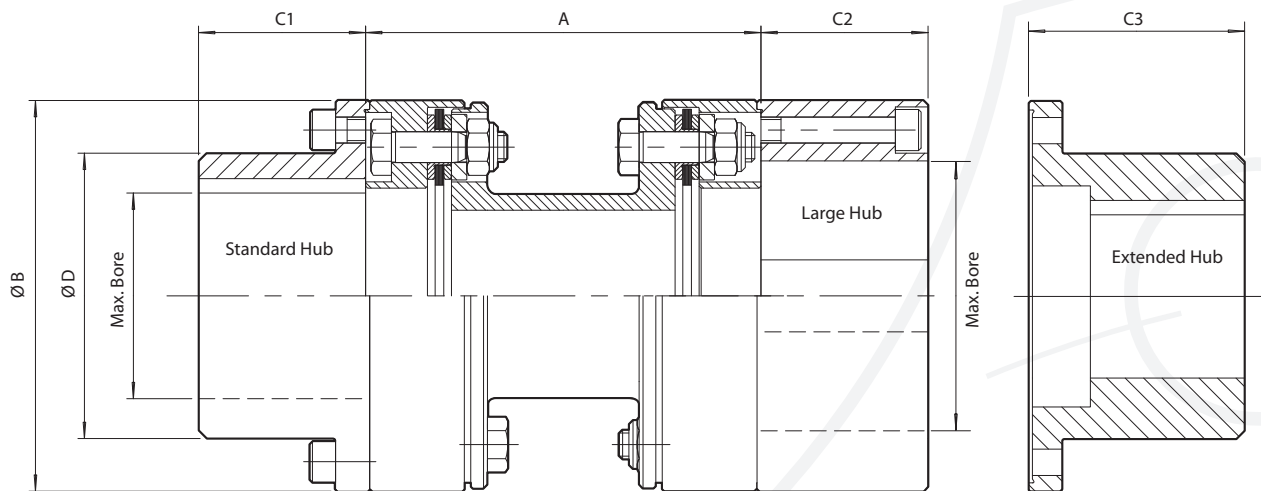

**ECS - 6 Link
Spacer Coupling**

Technical Details

Coupling Size - Links	Rating kW/100 rpm	Torque Rating		Maximum Speed ②		① Weight (kg)	Weight per m of extra DBSE (kg)	① Inertia (kgm ²)	Inertia per m of extra DBSE (kgm ² /m)	Misalignment ③	
		Cont. (Nm)	Peak (Nm)	Unbal. (rpm)	Bal. (rpm)					Axial (mm)	Parallel (mm)
11 - 4	12	110	220	8,900	21,000	3.48	5.60	0.00371	0.00287	1.50	0.62
19 - 4	20	190	380	8,000	19,000	5.63	7.25	0.00815	0.00460	1.90	0.72
15 - 6	16	150	270	9,100	24,000	3.25	4.61	0.00359	0.00153	0.76	0.34
35 - 6	37	350	620	7,800	19,000	6.33	6.56	0.0110	0.00449	0.97	0.44
70 - 6	73	700	1,240	7,100	16,000	9.58	13.4	0.0249	0.0159	1.12	0.44
130 - 6	136	1,300	2,600	6,400	14,000	14.6	11.5	0.0479	0.0154	1.33	0.49
150 - 6	157	1,500	2,680	6,100	12,000	18.3	27.9	0.0770	0.0632	1.47	0.46
220 - 6	230	2,200	4,400	5,700	12,000	24.5	17.8	0.111	0.0367	1.57	0.56
330 - 6	346	3,300	6,600	5,200	10,000	36.6	23.2	0.226	0.0568	1.79	0.65
480 - 6	502	4,800	9,600	4,800	9,100	50.7	31.0	0.388	0.0996	2.02	0.72
700 - 6	733	7,000	14,000	4,400	8,200	71.2	30.7	0.684	0.156	2.29	0.79
880 - 6	921	8,800	17,600	4,200	7,400	93.9	30.9	1.10	0.191	2.49	0.90
1300 - 6	1,360	13,000	26,000	3,900	6,500	131	41.2	2.00	0.315	2.89	0.95

1) Weight and Inertias are calculated using maximum bored standard hubs and minimum DBSE.

2) Maximum Unbalanced Speeds are based on AGMA 9000-C90 Class 9 with min DBSE and max interference bored couplings with standard hubs.

3) Maximum Parallel Offset is based on a minimum DBSE (1/2 Deg. Angular misalignment per membrane pack).

Dimensional Details

Coupling Size - Links	Maximum Bore ④		A Min DBSE (mm)	B (mm)	C1 (mm)	C2 (mm)	C3 (mm)	D (mm)	Stock DBSE ("A") Dimension (mm)				
	Std. & Ext. Hub (mm)	Large Hub (mm)							100	120	140	180	250
11 - 4	42	60	70	91.2	33.3	41.1	42.9	58.7	●	●	●		
19 - 4	51	75	85	106	39.6	46.0	52.3	71.4	●	●	●		
15 - 6	45	60	80	89.0	36.5	36.5	50.8	60	●	●	●		
35 - 6	55	74	100	110	46.0	46.0	63.5	75	●	●	●	●	
70 - 6	75	95	100	133	58.7	58.7	76.2	100	●	●	●	●	
130 - 6	80	105	114	152	65.0	65.0	82.6	111		●	●	●	
150 - 6	95	112	108	170	74.5	74.5	92.2	130			●	●	●
220 - 6	90	125	131	180	75.0	75.0	95.3	131				●	●
330 - 6	120	146	152	205	90.0	90.0	111	163				●	●
480 - 6	130	-	169	230	95.0	95.0	127	181				●	●
700 - 6	140	-	185	257	110	110	137	206					●
880 - 6	155	-	210	282	120	120	152	223					●
1300 - 6	175	-	223	325	130	130	159	248					●

4) Maximum Bore assumes an interference fit with a rectangular key.

5) Bolted tube spacers available.

NOTE: The ECS Coupling is used on 4 bearing systems, such as API 610 motor to pump applications and where Drop Out Transmission Units are required.

AUTOFLEX SERIES HVII

TYPE ECS COUPLINGS (DOUBLE FLEX - SPACER)

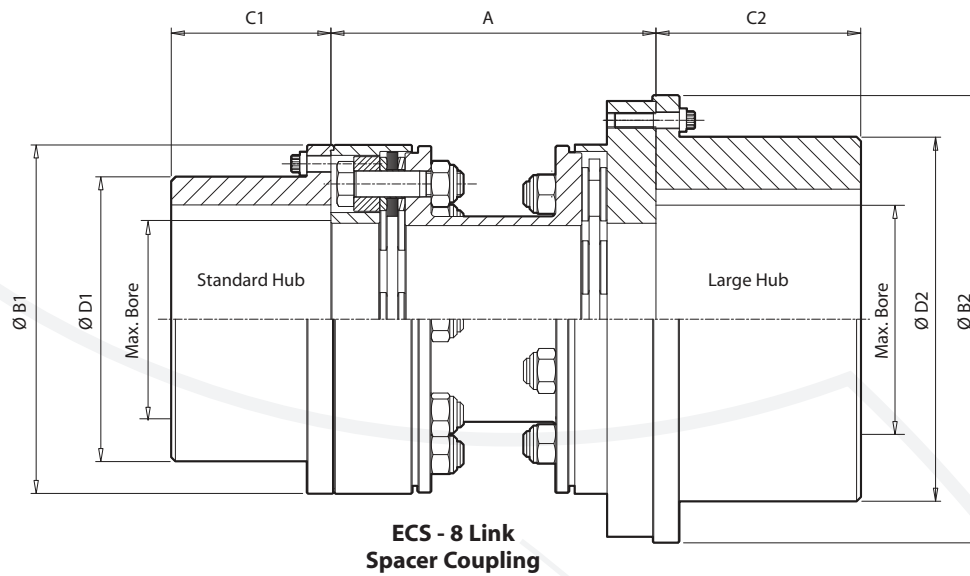

Technical Details

Coupling Size - Links	Rating kW/100 rpm	Torque Rating		Maximum Speed ②		① Weight (kg)	Weight per m of extra DBSE (kg/m)	① Inertia (kgm ²)	Inertia per m of extra DBSE (kgm ² /m)	Misalignment ③	
		Cont. (Nm)	Peak (Nm)	Unbal. (rpm)	Bal. (rpm)					Axial (mm)	Parallel (mm)
340 - 8	353	3,400	6,800	6,100	12,800	18.5	10.4	0.0775	0.0228	3.4	0.34
510 - 8	537	5,100	10,200	5,500	11,300	28.1	13.4	0.153	0.0391	3.9	0.39
740 - 8	778	7,400	14,800	5,100	10,000	41.1	16.8	0.286	0.0643	4.4	0.43
1040 - 8	1,086	10,400	20,800	4,600	9,000	59.8	21.8	0.521	0.100	4.9	0.49
1410 - 8	1,481	14,100	28,200	4,300	8,200	81.3	26.2	0.868	0.150	5.4	0.53
1900 - 8	1,989	19,000	38,000	4,100	7,500	102	32.7	1.28	0.223	5.9	0.57
2500 - 8	2,618	25,000	50,000	3,800	7,200	142	43.2	1.97	0.303	6.1	0.65
2870 - 8	3,001	28,700	57,400	3,700	6,400	165	40.8	2.88	0.382	6.9	0.64
3590 - 8	3,757	35,900	71,800	3,500	6,000	199	48.9	3.92	0.527	7.4	0.71
4420 - 8	4,631	44,200	88,400	3,400	5,600	242	55.0	5.47	0.679	7.9	0.74
7240 - 8	7,585	72,400	144,800	3,000	4,700	403	73.9	12.9	1.36	9.4	0.85
11660 - 8	12,205	116,600	233,200	2,700	4,000	652	105	28.5	2.58	11.0	1.0
20000 - 8	20,944	200,000	400,000	2,400	3,400	1,095	151	67.2	5.13	13.1	1.2

1) Weight and Inertias are calculated using maximum bored standard hubs and minimum DBSE.

2) Maximum Unbalanced Speeds are based on AGMA 9000-C90 Class 9 with min DBSE and max interference bored coupling hubs.

3) Maximum Parallel Offset is based on a minimum DBSE (1/3 Deg. Angular misalignment per membrane pack).

Dimensional Details

Coupling Size - Links	Maximum Bore ④		A Min DBSE (mm)	B1 (mm)	B2 (mm)	C1 Std. Hub (mm)	C2 Large Hub (mm)	D1 Std. Hub (mm)	D2 Large Hub (mm)
	Std. Hub (mm)	Large Hub (mm)							
340 - 8	94	124	124	171	219	74.5	98.5	132	173
510 - 8	107	134	142	195	243	85.7	110	150	187
740 - 8	124	151	159	219	268	98.5	123	173	211
1040 - 8	134	169	180	243	310	110	165	187	236
1410 - 8	151	194	196	268	344	123	158	211	272
1900 - 8	159	203	212	293	368	130	163	222	284
2500 - 8	169	-	246	310	-	165	-	236	-
2870 - 8	194	-	238	344	-	158	-	272	-
3590 - 8	203	-	262	368	-	163	-	284	-
4420 - 8	220	-	274	393	-	178	-	308	-
7240 - 8	255	-	317	464	-	210	-	357	-
11660 - 8	307	-	375	538	-	250	-	430	-
20000 - 8	368	-	448	640	-	297	-	515	-

4) Maximum Bore assumes an interference fit with a rectangular key.

NOTE: The ECS Coupling is used on 4 bearing systems, such as API 610 motor to pump applications and where high power and Drop Out Transmission Units are required

AUTOFLEX SERIES HR11 & HFT11

The advanced features of the Autoflex Membrane couplings are now available as a "Drop-In" upgrade for your existing Thomas Series 71™ or Metastream T-Series™ Couplings.

The "Drop-In" Advantage

- No need for expensive hub removal or machining as you keep your existing hubs.
- Locates on existing hub spigot for accurate run-out and balance.
- Retains original shaft separation.

The Autoflex Advantage

- Bolted spacer option offers quick turnaround for non standard DBSE's
- Unique gagging feature for jig-free dynamic balancing of transmission unit & hub.
- Anti-fly guard rings for increased safety
- ATEX Approval - See page 3 for details



SERIES HR11 "DROP-IN" FOR THOMAS™ SERIES 71 COUPLINGS

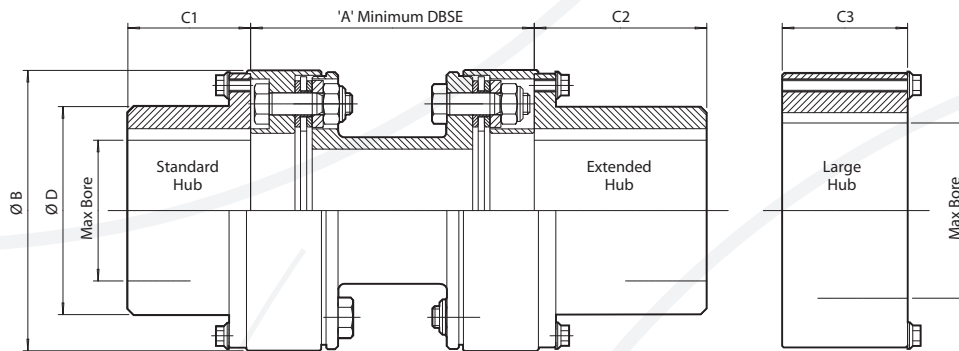

ECS HR11 4 & 6 - Link
"Drop-In" for Thomas™ Series 71

Technical Details

Coupling Size - Links	Thomas™ Series 71	Rating kW/100 rpm	Torque Rating		Maximum Speed ②		① Weight (kg)	Weight per m of extra DBSE (kg/m)	① Inertia (kgm²)	Inertia per m of extra DBSE (kgm²/m)	Misalignment ③	
			Cont. (Nm)	Peak (Nm)	Unbal. (rpm)	Bal. (rpm)					Axial (mm)	Parallel (mm)
11 - 4	150	12	110	220	8,900	21,000	3.48	5.60	0.00371	0.00287	1.50	0.62
19 - 4	175	20	190	380	8,000	19,000	5.63	7.25	0.00815	0.00460	1.90	0.72
35 - 6	225	37	350	620	6,300	17,000	8.37	6.56	0.0170	0.00449	0.97	0.44
130 - 6	300	136	1,300	2,600	5,500	14,000	15.0	11.5	0.0476	0.0154	1.33	0.49
200 - 6	350	230	2,200	4,400	4,900	12,000	24.4	17.8	0.107	0.0367	1.57	0.56
220 - 6	375	230	2,200	4,400	4,700	11,000	29.6	17.8	0.148	0.0367	1.57	0.56

1) Weight and Inertias are calculated using maximum bored standard hubs and minimum DBSE.

2) Maximum Unbalanced Speeds are based on AGMA 9000-C90 Class 9 with min DBSE and max interference bored coupling hubs.

3) Maximum Parallel Offset is based on a minimum DBSE (1/2 Deg. Angular misalignment per membrane pack).

Dimensional Details

Coupling Size - Links	Thomas™ Series 71	Maximum Bore ④		A Min DBSE (mm)	B (mm)	C1 (mm)	C2 (mm)	C3 (mm)	D (mm)
		Std. & Ext. Hub (mm)	Large Hub (mm)						
11 - 4	150	42	60	70	91.2	33.3	42.9	41.1	58.7
19 - 4	175	51	75	85	106	39.6	52.3	46.0	71.4
35 - 6	225	61	90	100	126	50.8	63.5	52.3	84.8
130 - 6	300	81	108	114	152	66.5	82.6	69.9	113
200 - 6	350	95	122	131	180	79.2	95.3	76.2	133
220 - 6	375	103	138	131	194	82.6	102	82.6	144

4) Maximum Bore assumes an interference fit with a rectangular key.

5) Thomas Series 71 is a registered Trade Mark of Rexnord Industries Inc.

6) Metastream T-Series is a registered Trade Mark of John Crane Ltd.

NOTE: When ordering please advise if a Transmission Unit or coupling complete with hubs is required.

AUTOFLEX SERIES HFTII

“DROP-IN” FOR METASTREAM™ “T” SERIES COUPLINGS

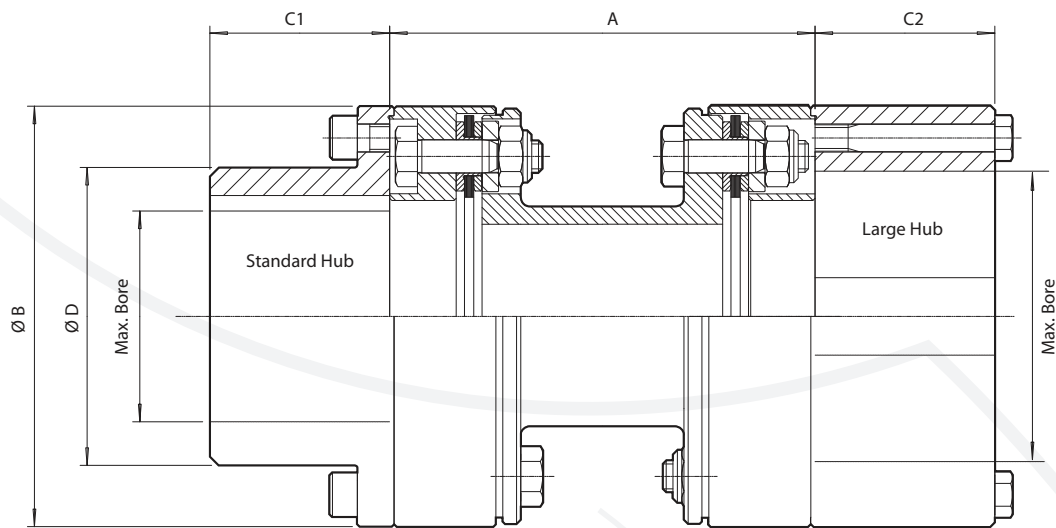

**ECS HFTII - 6 Link
“Drop-In” for Metastream™ “T” Series Coupling**

Technical Details

(Socket head cap screws supplied with every Transmission Unit)

Coupling Size - Links	Metastream™ “T” series	Rating kW/100 rpm	Torque Rating		Maximum Speed ②		① Weight (kg)	Weight per m of extra DBSE (kg/m)	① Inertia (kgm ²)	Inertia per m of extra DBSE (kgm ² /m)	Misalignment ③	
			Cont. (Nm)	Peak (Nm)	Unbal. (rpm)	Bal. (rpm)					Axial (mm)	Parallel (mm)
15 - 6	TSKS 0013	16	150	270	9,100	24,000	3.43	4.61	0.0036	0.00153	0.76	0.34
35 - 6	TSKS 0033	37	350	620	7,800	19,000	6.47	6.56	0.0109	0.00449	0.97	0.44
70 - 6	TSKS 0075	73	700	1,240	7,100	16,000	9.32	13.4	0.0234	0.0159	1.12	0.44
130 - 6	TSKS 0135	136	1,300	2,600	6,400	14,000	14.6	11.5	0.0479	0.0154	1.33	0.49
220 - 6	TSKS 0230	230	2,200	4,400	5,700	12,000	24.5	17.8	0.111	0.0367	1.57	0.56
330 - 6	TSKS 0350	346	3,300	6,600	5,200	10,000	36.6	23.2	0.226	0.0568	1.79	0.65
480 - 6	TSKS 0500	502	4,800	9,600	4,800	9,100	50.7	31.0	0.388	0.0996	2.02	0.72
700 - 6	TSKS 0740	733	7,000	14,000	4,400	8,200	71.2	30.7	0.684	0.156	2.29	0.79
880 - 6	TSKS 0930	921	8,800	17,600	4,200	7,400	93.9	30.9	1.10	0.191	2.49	0.90
1300 - 6	TSKS 1400	1,360	13,000	26,000	3,900	6,500	131	41.2	2.00	0.315	2.89	0.95

1) Weight and Inertias are calculated using maximum bored standard hubs and minimum DBSE.

2) Maximum Unbalanced Speeds are based on AGMA 9000-C90 Class 9 with min DBSE and max interference bored coupling hubs.

3) Maximum Parallel Offset is based on a minimum DBSE (1/2 Deg. Angular misalignment per membrane pack).

Dimensional Details

Coupling Size - Links	Metastream™ “T” Series	Maximum Bore ④		A Min DBSE (mm)	B (mm)	C1 (mm)	C2 (mm)	D (mm)
		Std. Hub (mm)	Large Hub (mm)					
15 - 6	TSKS 0013	36	51	80	89	40	40	54
35 - 6	TSKS 0033	46	70	100	110	45	45	69
70 - 6	TSKS 0075	65	90	100	133	55	55	90
130 - 6	TSKS 0135	80	105	114	152	62	62	111
220 - 6	TSKS 0230	90	125	131	180	70	70	131
330 - 6	TSKS 0350	120	140	152	205	90	90	163
480 - 6	TSKS 0500	130	-	169	230	95	-	181
700 - 6	TSKS 0740	140	-	185	257	107	-	206
880 - 6	TSKS 0930	155	-	210	282	115	-	223
1300 - 6	TSKS 1400	175	-	223	325	130	-	248

4) Maximum Bore assumes an interference fit with a rectangular key.

5) Metastream T series is a registered Trade Mark of John Crane Ltd.

NOTE: When ordering please advise if a Transmission Unit or coupling complete with hubs is required.

“Drop-in” for Metastream™ TSCS (Imperial Version) can be supplied on request – consult Autogard.

AUTOFLEX SERIES HVII

TYPE CCA COUPLINGS (CLOSE COUPLED - AXIALLY SPLIT)

The Autoflex CCA is offered in both a six and eight link membrane designs. The six link is suitable for light to medium duty applications, allows for very short DBSE's and is often used when replacing the Thomas DBZ™ Coupling.

The CCA eight-link coupling has been designed for heavy-duty applications and is often offered when replacing gear or grid style couplings.

The Autoflex CCA is comprised of two coupling hubs, two guard rings, two membrane packs and one axial split spacer. The axial split spacer is spigoted to the guard ring to provide a good balance characteristic.

The coupling can be installed with hubs reversed as shown offering the maximum flexibility in DBSE selection. The coupling has been designed to allow the user to replace membrane packs without moving the driving or the driven equipment. Simply remove the axial split spacer and remove the membrane pack from between the hub faces.

The CCA has been designed to meet AGMA 8-balance classification. Dynamic Balancing is offered which will increase the balance to an AGMA class 9.

Refer to the Autoflex CCR for higher speed requirements.

CCA - 6 LINK (MEDIUM DUTY)

Technical Details

Coupling Size - Links	Rating kW/1000 rpm	Torque Rating		Maximum Speed ②		① Weight (kg)	① Inertia (kgm²)	Misalignment ③	
		Cont. (Nm)	Peak (Nm)	Unbal. (rpm)	Bal. (rpm)			Axial (mm)	Parallel (mm)
15 - 6	16	150	270	6,300	10,800	1.98	0.00192	0.76	0.67
35 - 6	37	350	620	5,300	9,000	3.95	0.00627	0.97	0.83
70 - 6	73	700	1,240	4,800	7,800	5.95	0.0135	1.12	0.93
130 - 6	136	1,300	2,600	4,100	7,000	11.1	0.0332	1.33	1.20
150 - 6	157	1,500	2,680	3,900	6,500	12.8	0.0455	1.47	1.27
220 - 6	230	2,200	4,400	3,600	6,200	17.7	0.0731	1.57	1.36
330 - 6	346	3,300	6,600	3,300	5,500	25.6	0.142	1.79	1.54
480 - 6	502	4,800	9,600	3,000	5,100	38.0	0.261	2.02	1.81
700 - 6	733	7,000	14,000	2,700	4,700	52.8	0.458	2.29	1.99
880 - 6	921	8,800	17,600	2,600	4,300	68.5	0.714	2.49	2.17
1300 - 6	1,360	13,000	26,000	2,400	3,900	97.8	1.36	2.89	2.36

1) Weights and Inertias are calculated using maximum bored standard hubs and minimum DBSE.

2) Maximum Unbalanced Speeds are based on AGMA 9000-C90 Class 9 with min DBSE and max interference bored coupling hubs.

3) Maximum Parallel Offset is based on a minimum DBSE (1/2 Deg. Angular misalignment per membrane pack).

Dimensional Details

Coupling Size - Links	④ Maximum Bore (mm)	A1 Min DBSE (mm)	A2 Rev Hub (mm)	B (mm)	C (mm)	D (mm)	E1 (mm)	E2 (mm)
15 - 6	32	3	-	85	37	44.6	77	-
35 - 6	43	3	-	108	46	59.9	95	-
70 - 6	54	3	-	128	52	74.9	107	-
130 - 6	57	5	59	148	66	79.1	153	199
150 - 6	67	5	65	163	70	94.0	156	211
220 - 6	69	6	67	174	75	96.6	174	226
330 - 6	85	6	75	200	85	118.4	196	255
480 - 6	94	7	89	223	100	131.8	231	301
700 - 6	107	8	98	250	110	149.4	254	331
880 - 6	119	9	107	273	120	166.4	277	361
1300 - 6	138	10	116	314	130	193.5	300	391

4) Maximum Bore assumes an interference fit with a rectangular key.

5) Thomas DBZ™ is a registered Trade Mark of Rexnord Industries Inc.

AUTOFLEX SERIES HVII

TYPE CCA COUPLINGS (CLOSE COUPLED - AXIALLY SPLIT)

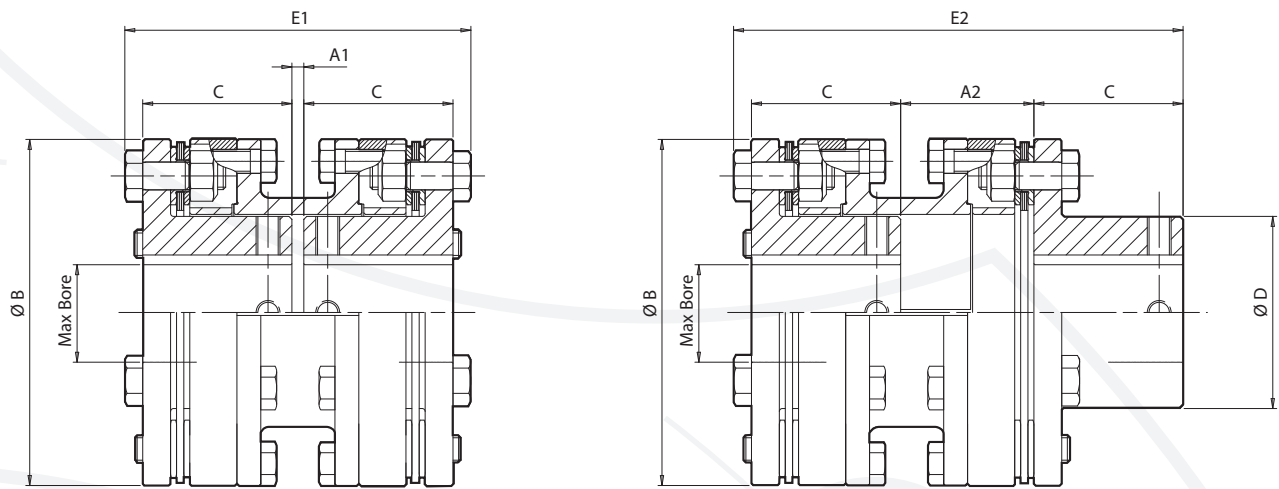

CCA 6 & 8 - Link Couplings

CCA - 8 LINK (HEAVY DUTY)

Technical Details

Coupling Size - Links	Rating kW/1000 rpm	Torque Rating		Maximum Speed ②		① Weight (kg)	① Inertia (kgm ²)	Misalignment ③	
		Cont. (Nm)	Peak (Nm)	Unbal. (rpm)	Bal. (rpm)			Axial (mm)	Parallel (mm)
1410 - 8	1,481	14,100	28,200	2,700	4,500	58.3	0.535	5.4	1.4
1900 - 8	1,989	19,000	38,000	2,500	4,200	75.5	0.823	5.9	1.5
2500 - 8	2,618	25,000	50,000	2,400	4,100	87.5	1.03	6.1	1.6
2870 - 8	3,001	28,700	57,400	2,300	3,700	116	1.74	6.9	1.7
3590 - 8	3,757	35,900	71,800	2,100	3,600	144	2.47	7.4	1.8
4420 - 8	4,631	44,200	88,400	2,000	3,400	173	3.38	7.9	1.9
7240 - 8	7,585	72,400	144,800	1,800	2,900	287	8.04	9.4	2.2
11660 - 8	12,205	116,600	233,200	1,600	2,600	458	17.3	11.0	2.6
20000 - 8	20,944	200,000	400,000	1,400	2,300	785	42.2	13.1	3.1

1) Weight and Inertias are calculated using maximum bored standard hubs and minimum DBSE.

2) Maximum Unbalanced Speeds are based on AGMA 9000-C90 Class 9 with min DBSE and max interference bored coupling hubs.

3) Maximum Parallel offset is based on a minimum DBSE (1/3 Deg. Angular misalignment per membrane pack).

Dimensional Details

Coupling Size - Links	④ Maximum Bore (mm)	A1 Min DBSE (mm)	A2 Rev Hub (mm)	B (mm)	C (mm)	D (mm)	E1 (mm)	E2 (mm)
1410 - 8	111	11	106	258	115	155.3	267	349
1900 - 8	121	12	115	281	125	170.0	290	379
2500 - 8	125	12	119	292	132	174.4	304	397
2870 - 8	142	13	127	330	139	199.1	321	420
3590 - 8	152	14	138	353	151	213.1	350	457
4420 - 8	163	15	146	377	160	228.0	369	483
7240 - 8	195	16	167	449	184	272.7	426	556
11660 - 8	227	17	194	522	217	317.7	501	653
20000 - 8	271	19	230	622	259	379.4	597	778

4) Maximum Bore assumes an interference fit with a rectangular key.

AUTOFLEX SERIES HVII

TYPE CCR COUPLINGS (CLOSE COUPLED - RADially SPLIT)

The Autoflex CCR is offered in both a six and eight link membrane designs. The six-link design is suitable for medium duty high-speed applications. The CCR eight-link coupling has been designed for heavy-duty high-speed applications with very short DBSE's and is often offered when replacing high performance gear couplings. This allows for easy conversion between lubricated couplings to non-lubricated, zero maintenance membrane style couplings.

The Autoflex CCR is comprised of two coupling hubs, two guard rings and two membrane packs. The radial split guard rings are spigoted ensuring the highest level of balance.

The CCR has been designed to meet AGMA class 9 as manufactured and can be balanced to meet the AGMA class 11 or API 610 8th edition requirements.

The coupling can be installed with hubs reversed, offering the maximum flexibility in DBSE selection. The coupling has been designed with waisted link membranes making one of the most flexible couplings available today. In addition, the coupling comes with overload collars, which protects the coupling from high peak loads.

Refer to the Autoflex CCA to allow replacement of membranes without moving the driving or driven equipment.

CCR - 6 LINK (MEDIUM DUTY)

Technical Details

Coupling Size - Links	Rating kW/1000 rpm	Torque Rating		Maximum Speed ②		① Weight (kg)	① Inertia (kgm ²)	Misalignment ③	
		Cont. (Nm)	Peak (Nm)	Unbal. (rpm)	Bal. (rpm)			Axial (mm)	Parallel (mm)
15 - 6	16	150	270	9,500	18,000	2.68	0.0040	0.76	0.41
35 - 6	37	350	620	8,300	15,000	4.72	0.0098	0.97	0.42
70 - 6	73	700	1,240	7,400	13,000	7.79	0.0218	1.12	0.51
130 - 6	136	1,300	2,600	6,900	11,000	10.6	0.0407	1.33	0.53
220 - 6	230	2,200	4,400	6,200	9,600	16.8	0.0849	1.57	0.63
330 - 6	346	3,300	6,600	5,600	8,300	25.4	0.170	1.79	0.73
480 - 6	502	4,800	9,600	5,200	7,300	36.1	0.303	2.02	0.80
700 - 6	733	7,000	14,000	4,900	6,800	47.5	0.493	2.29	0.92
880 - 6	921	8,800	17,600	4,500	6,000	65.8	0.851	2.49	1.03
1300 - 6	1,360	13,000	26,000	4,100	5,400	97.1	1.55	2.89	1.29

1) Weights and Inertias are calculated using maximum bored standard hubs and minimum DBSE.

2) Maximum Unbalanced Speeds are based on AGMA 9000-C90 Class 9 with min DBSE and max interference bored coupling hubs.

3) Maximum Parallel Offset is based on a minimum DBSE (1/2 Deg. Angular misalignment per membrane pack).

Dimensional Details

Coupling Size - Links	④ Maximum Bore (mm)	DBSE			B (mm)	C (mm)	D (mm)	E1 (mm)	E2 (mm)	E3 (mm)
		A1 Min (mm)	A2 1 Hub Rev (mm)	A3 2 Hubs Rev (mm)						
15 - 6	28	3	28.5	54.0	118	35	40	73	98.5	124.0
35 - 6	40	3	30.3	57.6	140	40	59	83	110.3	137.6
70 - 6	55	3	25.2	47.5	163	55	84	113	135.2	157.5
130 - 6	60	3	24.6	46.2	190	60	83	123	144.6	166.2
220 - 6	70	3	28.6	54.1	218	70	100	143	168.6	194.1
330 - 6	80	3	33.0	63.0	254	80	117	163	193.0	223.0
480 - 6	90	3	36.9	70.9	286	90	131	183	216.9	250.9
700 - 6	105	3	41.9	80.7	310	100	148	203	241.9	280.7
880 - 6	115	3	49.1	95.2	350	110	165	223	269.1	315.2
1300 - 6	130	3	62.8	122.5	392	130	193	263	322.8	382.5

4) Maximum Bore assumes an interference fit with a rectangular key.

AUTOFLEX SERIES HVII

TYPE CCR COUPLINGS (CLOSE COUPLED - RADially SPLIT)

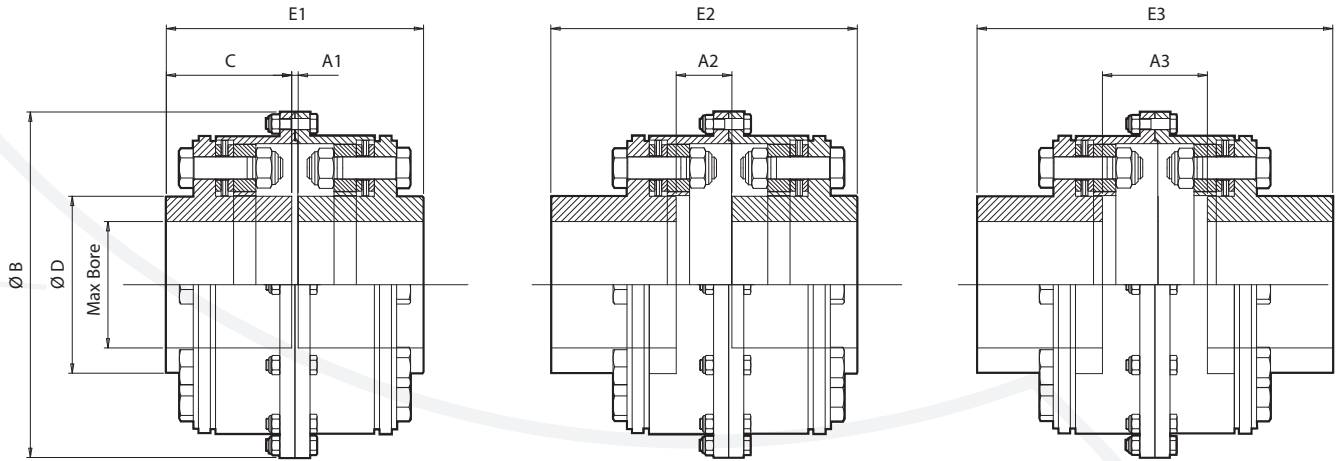

CCR 6 & 8 - Link Couplings

CCR - 8 LINK (HEAVY DUTY)

Technical Details

Coupling Size - Links	Rating kW/1000 rpm	Torque Rating		Maximum Speed ②		① Weight (kg)	① Inertia (kgm ²)	Misalignment ③	
		Cont. (Nm)	Peak (Nm)	Unbal. (rpm)	Bal. (rpm)			Axial (mm)	Parallel (mm)
340 - 8	353	3,400	6,800	6200	9700	16.8	0.0784	3.4	0.44
510 - 8	537	5,100	10,200	5700	8600	25.0	0.149	3.9	0.50
740 - 8	778	7,400	14,800	5200	7800	35.0	0.256	4.4	0.56
1040 - 8	1,086	10,400	20,800	4900	7100	47.8	0.428	4.9	0.61
1410 - 8	1,481	14,100	28,200	4500	6400	64.9	0.711	5.4	0.68
1900 - 8	1,989	19,000	38,000	4300	5900	84.9	1.11	5.9	0.74
2500 - 8	2,618	25,000	50,000	4000	5600	107	1.56	6.1	0.70
2870 - 8	3,001	28,700	57,400	3900	5100	132	2.33	6.9	0.95
3590 - 8	3,757	35,900	71,800	3700	4800	165	3.34	7.4	1.00
4420 - 8	4,631	44,200	88,400	3500	4500	200	4.61	7.9	1.09
7240 - 8	7,585	72,400	144,800	3100	3800	321	10.3	9.4	1.30
11660 - 8	12,205	116,600	233,200	2800	3300	506	21.8	11.0	1.54
20000 - 8	20,944	200,000	400,000	2500	2800	841	50.7	13.1	1.76

1) Weights and Inertias are calculated using maximum bored standard hubs and minimum DBSE.

2) Maximum Unbalanced Speeds are based on AGMA 9000-C90 Class 9 with min DBSE and max interference bored coupling hubs.

3) Maximum Parallel Offset is based on a minimum DBSE (1/3 Deg. Angular misalignment per membrane pack).

Dimensional Details

Coupling Size - Links	④ Maximum Bore (mm)	DBSE			B (mm)	C (mm)	D (mm)	E1 (mm)	E2 (mm)	E3 (mm)
		A1 Min (mm)	A2 1 Hub Rev (mm)	A3 2 Hubs Rev (mm)						
340 - 8	70	4	31	58	217	70	98	144	171	198
510 - 8	81	4	34	64	245	80	113	164	194	224
740 - 8	91	5	39	73	269	90	127	185	219	253
1040 - 8	101	5	41	77	297	100	141	205	241	277
1410 - 8	111	6	46	86	330	110	156	226	266	306
1900 - 8	122	6	50	94	355	120	171	246	290	334
2500 - 8	125	6	47	88	376	125	175	256	297	338
2870 - 8	144	7	67	127	410	145	201	297	357	417
3590 - 8	154	8	70	132	442	155	215	318	380	442
4420 - 8	164	8	78	148	467	165	229	338	408	478
7240 - 8	196	10	92	174	550	195	274	400	482	564
11660 - 8	228	12	108	204	642	230	319	472	568	664
20000 - 8	272	14	120	226	744	270	381	554	660	766

4) Maximum Bore assumes an interference fit with a rectangular key.

AUTOFLEX SERIES HVII

TYPE EB COUPLINGS (SINGLE FLEX)

The Autoflex EB coupling has been designed for medium and high duty applications. The coupling has been specifically designed for three bearing systems, which only require angular and axial misalignment capacity.

The coupling is offered with four, six and eight link membranes. The four and six link couplings have been optimised for medium duty application. The eight-link design offers higher torque capacities within a given diameter.

The coupling consists of three parts, two hubs and a membrane pack. The EB couplings use waisted link membranes which provide higher flexibility and ensure lower reaction forces on the driving and driven equipment.

The six and eight-link coupling also utilise overload collars to protect the coupling from high transient torques.

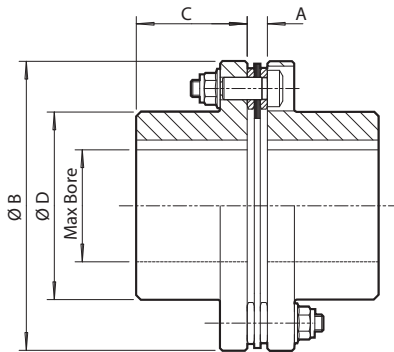

EB - 4 Link Coupling

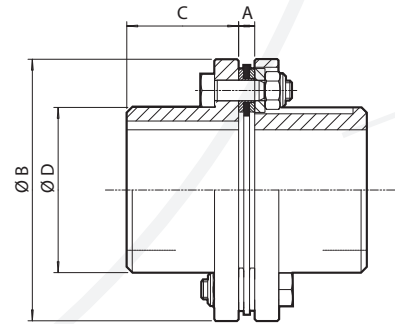

EB - 6 Link Coupling

Technical Details

Coupling Size - Links	Rating kW/1000 rpm	Torque Rating		Maximum Speed ②		① Weight (kg)	① Inertia (kgm ²)	Max. Axial Misalignment (mm)
		Cont. (Nm)	Peak (Nm)	Unbal. (rpm)	Bal. (rpm)			
11 - 4	12	110	220	11,700	21,000	1.07	0.000809	0.75
19 - 4	20	190	380	10,400	19,000	1.83	0.00196	0.95
15 - 6	16	150	270	11,600	12,800	1.12	0.00111	0.38
35 - 6	37	350	620	9,600	11,300	2.57	0.00383	0.49
70 - 6	73	700	1,240	8,500	10,000	4.27	0.00936	0.56
130 - 6	136	1,300	2,600	7,900	9,000	6.00	0.0165	0.67
150 - 6	157	1,500	2,680	6,800	8,200	11.2	0.0367	0.74
220 - 6	230	2,200	4,400	7,000	7,500	9.79	0.0378	0.79
330 - 6	346	3,300	6,600	6,400	7,200	15.0	0.0758	0.90
480 - 6	502	4,800	9,600	5,900	6,400	20.6	0.132	1.0
700 - 6	733	7,000	14,000	5,500	6,000	29.3	0.230	1.1
880 - 6	921	8,800	17,600	5,100	5,600	39.0	0.376	1.2
1300 - 6	1,360	13,000	26,000	4,700	4,700	55.7	0.718	1.4

1) Weights and Inertias are calculated using maximum bored standard hubs and minimum DBSE.

2) Maximum Unbalanced Speeds are based on AGMA 9000-C90 Class 9 with min DBSE and max interference bored coupling hubs.

Dimensional Details

Coupling Size - Links	Maximum Bore ③ (mm)	A DBSE (mm)	B (mm)	C (mm)	D (mm)
11 - 4	40	6.4	89	33.3	56.6
19 - 4	48	8.1	103	39.6	67
15 - 6	40	7.3	89	36.5	53
35 - 6	50	9.4	110	46.0	70.6
70 - 6	66	9.4	133	57.5	91
130 - 6	70	9.3	152	65.0	96
150 - 6	90	8.8	170	74.6	123
220 - 6	83	9.7	180	75.0	114
330 - 6	98	11.2	205	90.0	134
480 - 6	110	15.0	230	95.0	150
700 - 6	123	15.7	257	110	169
880 - 6	137	16.5	282	120	188
1300 - 6	160	19.2	325	130	218

3) Maximum Bore assumes an interference fit with a rectangular key.

NOTE: The EB Coupling is used on 3 bearing systems, and only accepts angular and axial misalignment. Do not use where offset misalignment occurs.

AUTOFLEX SERIES HVII

TYPE EB COUPLINGS (SINGLE FLEX)

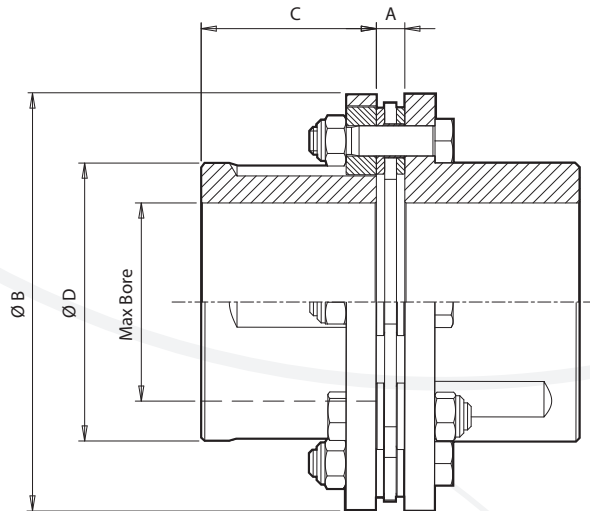

EB - 8 Link Couplings

Technical Details

Coupling Size - Links	Rating kW/1000 rpm	Torque Rating		Maximum Speed ②		① Weight (kg)	① Inertia (kgm ²)	Max. Axial Misalignment (mm)
		Cont. (Nm)	Peak (Nm)	Unbal. (rpm)	Bal. (rpm)			
340 - 8	353	3,400	6,800	7,200	12,800	9.09	0.0325	1.7
510 - 8	537	5,100	10,200	6,400	11,300	14.3	0.0650	2.0
740 - 8	778	7,400	14,800	5,900	10,000	20.3	0.118	2.2
1040 - 8	1,086	10,400	20,800	5,500	9,000	28.0	0.201	2.5
1410 - 8	1,481	14,100	28,200	5,200	8,200	36.9	0.324	2.7
1900 - 8	1,989	19,000	38,000	4,900	7,500	48.1	0.506	3.0
2500 - 8	2,618	25,000	50,000	4,600	7,200	61.2	0.721	3.0
2870 - 8	3,001	28,700	57,400	4,300	6,400	79.3	1.13	3.5
3590 - 8	3,757	35,900	71,800	4,100	6,000	97.2	1.59	3.7
4420 - 8	4,631	44,200	88,400	5,600	5,600	123	2.27	4.0
7240 - 8	7,585	72,400	144,800	4,700	4,700	206	5.26	4.7
11660 - 8	12,205	116,600	233,200	4,000	4,000	311	10.9	5.5
20000 - 8	20,944	200,000	400,000	3,400	3,400	546	26.6	6.5

1) Weights and Inertias are calculated using maximum bored standard hubs and minimum DBSE.

2) Maximum Unbalanced Speeds are based on AGMA 9000-C90 Class 9 with min DBSE and max interference bored coupling hubs.

Dimensional Details

Coupling Size - Links	③ Maximum Bore (mm)	A DBSE (mm)	B (mm)	C (mm)	D (mm)
340 - 8	81	13.0	171	65	113
510 - 8	91	14.4	195	80	128
740 - 8	104	16.3	219	90	145
1040 - 8	115	17.7	243	100	161
1410 - 8	126	19.4	268	105	177
1900 - 8	139	21.1	293	115	194
2500 - 8	144	20.9	310	130	201
2870 - 8	164	23.6	344	145	230
3590 - 8	174	25.3	368	155	243
4420 - 8	188	27.0	393	175	263
7240 - 8	223	30.2	464	215	312
11660 - 8	258	33.7	538	235	361
20000 - 8	305	38.8	640	300	427

3) Maximum Bore assumes an interference fit with a rectangular key.

NOTE: The EB Coupling is used on 3 bearing systems, and only accepts angular and axial misalignment. Do not use where offset misalignment occurs.

AUTOFLEX SERIES HVII

TYPE CB COUPLINGS (SINGLE FLEX)

The Autoflex CB coupling has been designed for medium and high duty applications. The coupling has been designed for three bearing systems which only require angular and axial misalignment capacity.

The coupling is offered with a six link membrane.

The couplings have been optimised for medium duty applications

The coupling consists of three parts, two hubs and a membrane cartridge pack. The CB couplings use waisted link membranes, which provide higher flexibility and ensures lower reaction forces on the driving and driven equipment.

The membrane cartridge pack allows for replacement of membranes without moving the driving or driven equipment.

The coupling also utilises overload collars to protect the coupling from high transient torques.

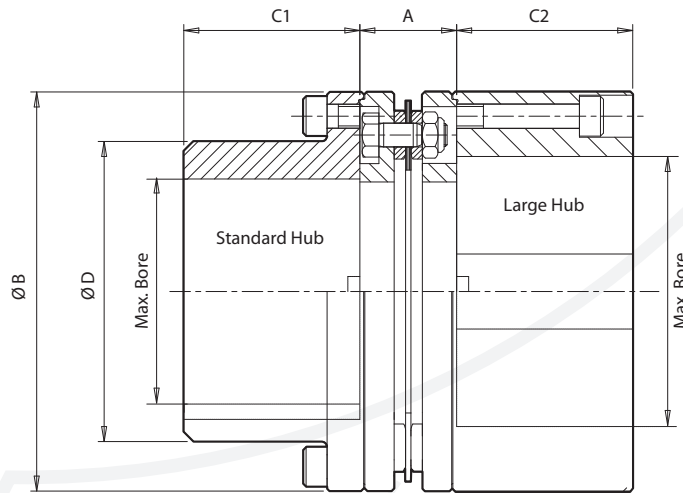

CB - 6 Link Coupling

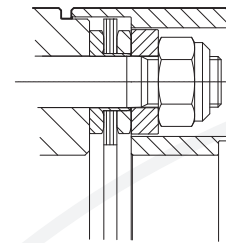

Size 150 and above have anti-fly guard rings

Technical Details

Coupling Size - Links	Rating kW/1000 rpm	Torque Rating ①		Maximum Speed ②		① Weight (kg)	① Inertia (kgm ²)	Max. Axial Misalignment (mm)
		Cont. (Nm)	Peak (Nm)	Unbal. (rpm)	Bal. (rpm)			
15 - 6	16	150	270	10,300	24,000	1.85	0.00200	0.38
35 - 6	37	350	620	8,700	19,000	3.82	0.00641	0.49
70 - 6	73	700	1,240	7,900	16,000	5.97	0.0150	0.56
150 - 6	157	1,500	2,680	6,500	12,000	13.8	0.0576	0.74
330 - 6	346	3,300	6,600	5,500	10,000	27.6	0.172	0.90
480 - 6	502	4,800	9,600	5,100	9,100	37.9	0.291	1.0

1) Weights and Inertias are calculated using maximum bored standard hubs and minimum DBSE.

2) Maximum Unbalanced Speeds are based on AGMA 9000-C90 Class 9 with min DBSE and max interference bored coupling hubs

Dimensional Details

Coupling Size - Links	Maximum Bore ③		A DBSE (mm)	B (mm)	C1 Std. Hub (mm)	C2 Large Hub (mm)	D (mm)
	Std. Hub (mm)	Large Hub (mm)					
15 - 6	45	60	25.4	89	36.5	36.5	60
35 - 6	55	74	32.3	110	46.0	46.0	75
70 - 6	75	90	32.3	133	58.7	58.7	100
150 - 6	95	112	54.9	170	74.5	74.5	130
330 - 6	120	140	77.7	205	90.0	90.0	163
480 - 6	130	-	85.7	230	95.0	-	181

3) Maximum Bore assumes an interference fit with a rectangular key.

NOTE: The CB Coupling is used on 3 bearing systems, and only accepts angular and axial misalignment.

Do not use where offset misalignment occurs.

AUTOFLEX SERIES HVII

TYPE CT-ES COUPLINGS (COOLING TOWER)

The Autoflex CT has been designed specifically for cooling tower drives with very long shaft separations. The driveshaft is made from a corrosion resistant, lightweight composite fibre material. Composite fibre has been proven to provide the optimum combination of stiffness in a lightweight package.

The coupling can be supplied in two styles

CT-ES - Economic Spacer arrangement

CT - ECS - Drop out Spacer arrangement

The CT coupling can also be supplied with optional bolted on cartridges. The major advantage of the bolted cartridge design is the ease of repair and replacement and the rationalisation of spares.

Two cartridge packs can be used as spares for a number of couplings.

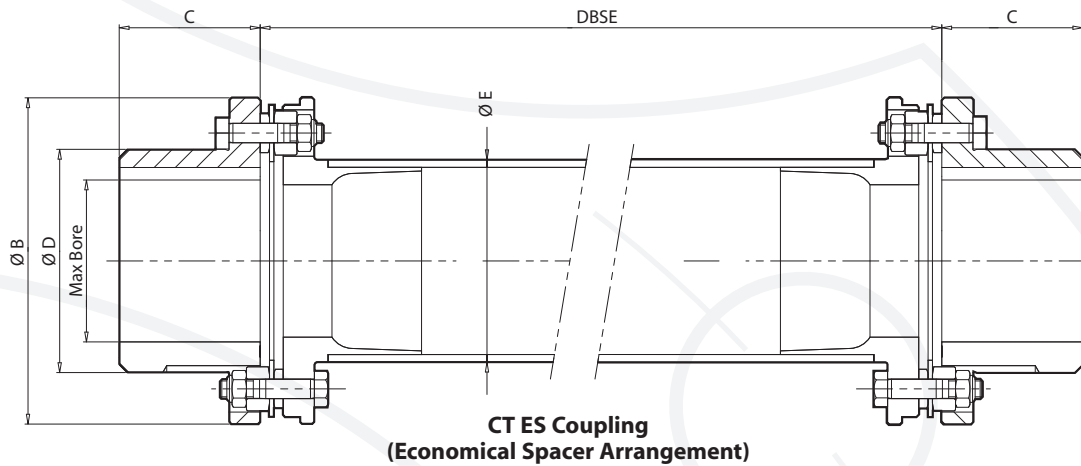

Technical Details

Coupling Size - Tube Dia.	Rating HP/100 rpm	Torque Rating		Weight ③ at 1m DBSE (kg)	Weight per m. of extra DBSE (kg/m)	Inertia ③ at 1m DBSE (kgm²)	Inertia per m. of extra DBSE (kgm²/m)	Misalignment	
		Cont. ① (Nm)	Peak ② (Nm)					Axial (mm)	Offset per DBSE Lgth (mm/mm)
70 - 3	73	700	1,240	8	1.25	0.017	0.002	1.12	8.2
70 - 6	73	700	1,240	12	2.45	0.042	0.015	1.12	
130 - 3	136	1,000	2,000	11	1.25	0.030	0.002	1.33	
130 - 6	136	1,300	2,600	15	2.45	0.056	0.015	1.33	
220 - 4	230	2,200	4,400	17	1.65	0.068	0.005	1.57	
220 - 8	230	2,200	4,400	27	3.25	0.15	0.035	1.57	
330 - 4	262	2,500	5,000	26	1.65	0.13	0.005	1.79	
330 - 8	346	3,300	6,600	35	3.25	0.22	0.035	1.79	

1) Torque values listed are for a service factor of 1.0. Standard service factor for cooling tower applications is 1.50.

2) Ensure peak capacity covers for maximum start-up torque.

3) Weights and Inertias are calculated using maximum bored standard hubs and 1m. DBSE.

Dimensional Details

Coupling Size - Tube Dia.	④ Max. Bore (mm)	Maximum DBSE ⑤		B (mm)	C (mm)	D (mm)	E (mm)
		at 1500 rpm (mm)	at 1800 rpm (mm)				
70 - 3	66	3.23	2.95	133	57.5	91	83
70 - 6	66	4.45	4.06	133	57.5	91	159
130 - 3	70	3.23	2.95	152	65.0	96	83
130 - 6	70	4.45	4.06	152	65.0	96	159
220 - 4	83	3.73	3.40	180	75.0	114	111
220 - 8	83	5.28	4.83	180	75.0	114	210
330 - 4	98	3.73	3.40	205	90.0	134	111
330 - 8	98	5.28	4.83	205	90.0	134	210

4) Maximum Bore assumes an interference fit with a rectangular key.

5) Longer DBSE's are available - consult Autogard Engineering.

NOTE: Other sizes available - consult Autogard Engineering. See opposite page for Oversize Tube Designs.

AUTOFLEX SERIES HVII

TYPE CT-ECS COUPLINGS (COOLING TOWER)

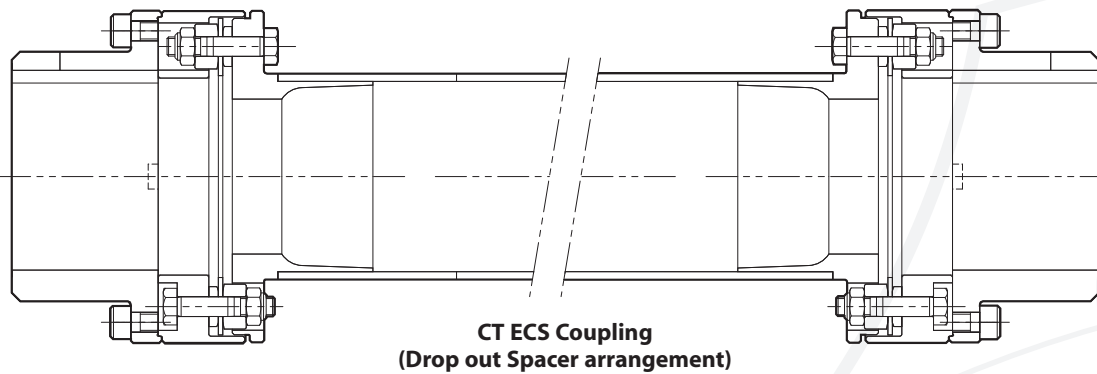

**CT ECS Coupling
(Drop out Spacer arrangement)**

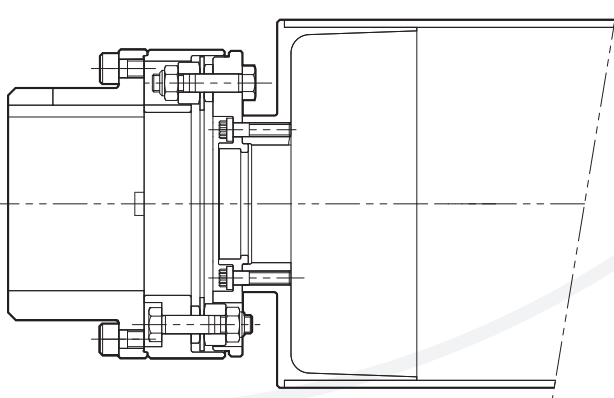

Oversized Tube Design - for longer DBSEs

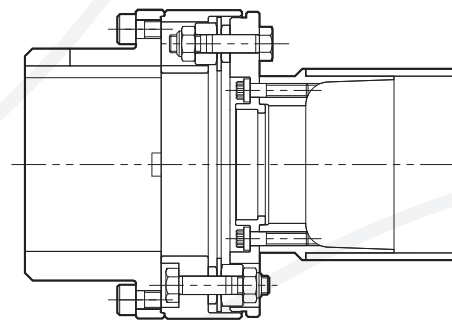

Optional Bolted Cartridge Assembly

Technical Details

Coupling Size - Tube Dia.	Rating kW/1000 rpm	Torque Rating		Weight at 1m DBSE (kg)	Weight per m. of extra (kg/m)	③ Inertia (kgm ²)	Inertia per m. of extra DBSE (kgm ² /m)	Misalignment	
		Cont. ① (Nm)	Peak ② (Nm)					Axial (mm)	Offset per DBSE (mm/mm)
70 - 3	73	700	1,240	11	1.25	0.027	0.002	1.12	8.2
70 - 6	73	700	1,240	15	2.45	0.052	0.015	1.12	
130 - 3	136	1,000	2,000	16	1.25	0.050	0.002	1.33	
130 - 6	136	1,300	2,600	20	2.45	0.076	0.015	1.33	
220 - 4	230	2,200	4,400	26	1.65	0.12	0.005	1.57	
220 - 8	230	2,200	4,400	36	3.25	0.20	0.035	1.57	
330 - 4	262	2,500	5,000	38	1.65	0.23	0.005	1.79	
330 - 8	346	3,300	6,600	48	3.25	0.32	0.035	1.79	

1) Torque values listed are for a service factor of 1.0. Standard service factor for cooling tower applications is 1.50.

2) Ensure peak capacity covers for maximum start-up torque.

3) Weights and Inertias are calculated using maximum bored standard hubs and 1m. DBSE.

Dimensional Details

Coupling Size - Tube Dia.	④ Max. Bore (mm)	Maximum DBSE ⑤		B (mm)	C (mm)	D (mm)	E (mm)
		at 1500 rpm (mm)	at 1800 rpm (mm)				
70 - 3	75	3.23	2.95	133	58.7	100	83
70 - 6	75	4.45	4.06	133	58.7	100	159
130 - 3	80	3.23	2.95	152	65.0	111	83
130 - 6	80	4.45	4.06	152	65.0	111	159
220 - 4	95	3.73	3.40	180	75.0	131	111
220 - 8	95	5.28	4.83	180	75.0	131	210
330 - 4	120	3.73	3.40	205	90.0	163	111
330 - 8	120	5.28	4.83	205	90.0	163	210

4) Maximum Bore assumes an interference fit with a rectangular key.

5) Longer DBSE's are available - consult Autogard Engineering.

AUTOFLEX METAL MEMBRANE COUPLINGS

Information for the Selection of Autoflex Couplings

Customer Name & Address

 Post Code
 Contact Name
 Phone / Fax No.
 E-mail Address

The Driver equipment
 (Electric motor, turbine, etc.)

The Driven equipment
 (Pump, Conveyor, etc.)

Duty Speed
 rpm

Driver Power
 kW

DBSE
 mm

Driver Bore Size
 mm
 Give full details on appropriate sketch

Driven Bore Size
 mm
 Give full details on appropriate sketch

Ambient Temperature
 Degs. C

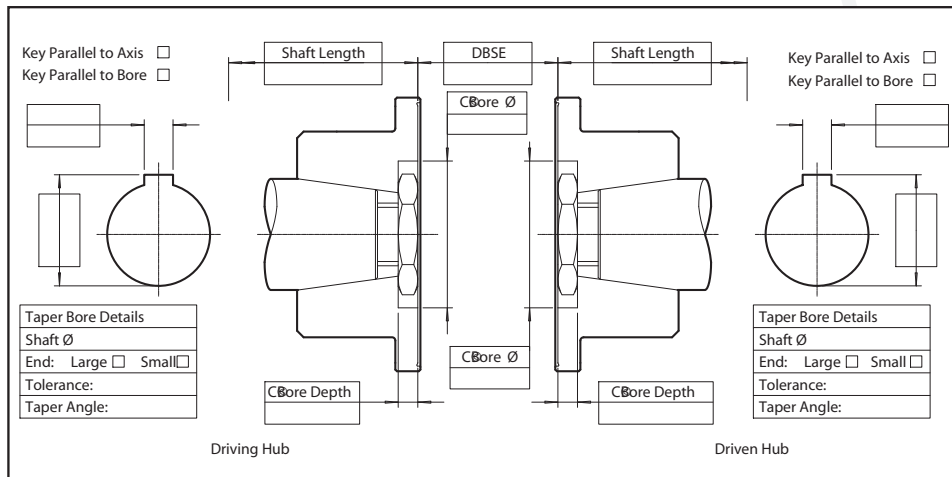
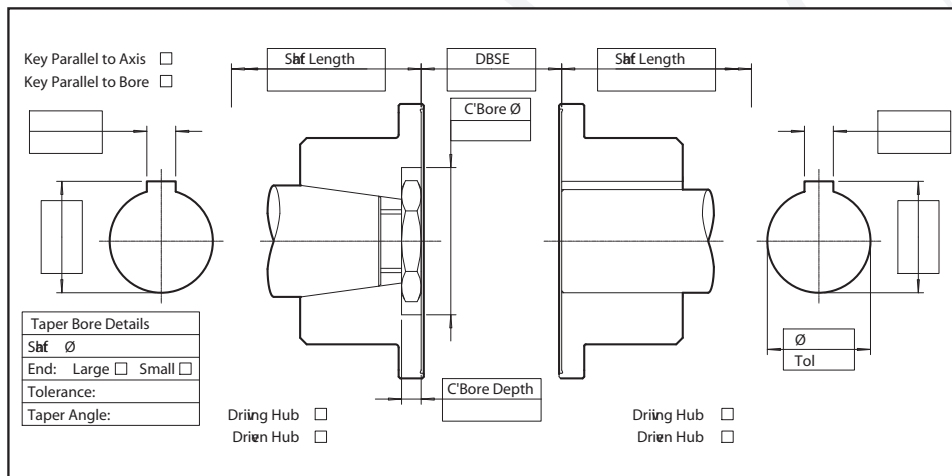
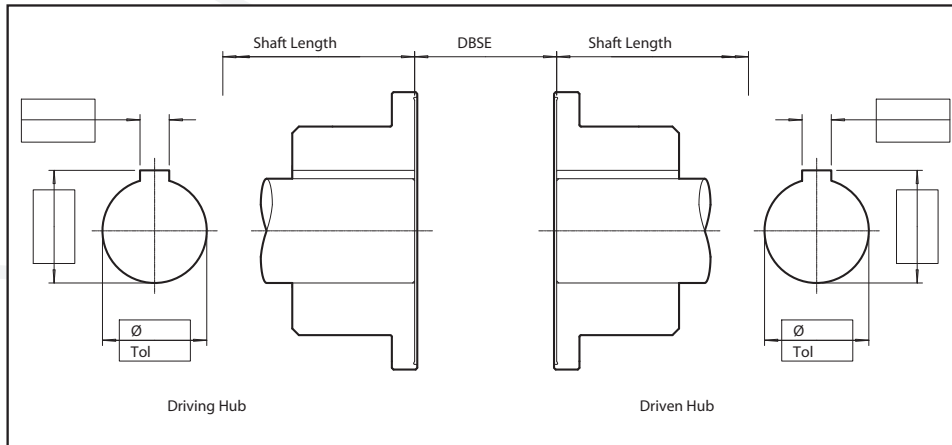

Options (Tick if required)

Balanced (Indicate Grade)

Spark Resistance

Puller Holes

Insulated

Axial Adjustment

Limited End Float

Trim Balance Holes

Profiled Hubs

Specifications API 610
 API 671
 None

OTHER AUTOFLEX PRODUCTS



SamiFlex Elastic Couplings

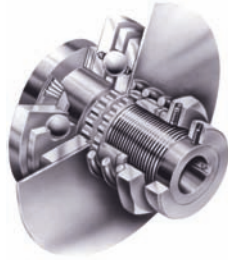

Autogard Series 200 Torque Limiters



Autogard Series 300 Torque Limiters



Monitorq

Monitorq - Torque Sensors



Autogard Series 400 Torque Limiters

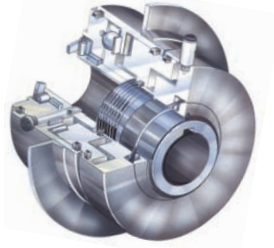

Autogard Series 600 Torque Limiters



Autogard Series 800 Torque Limiters



Autogard Power Monitors



Head Office

British Autogard Limited
Cirencester
Glos GL7 1YT
United Kingdom

Tel +44 (0) 1285 640333
Fax +44 (0) 1285 659476

Email sales@autogard.co.uk
Web www.autogard.com

For further information on
Autogard product range and
technical specifications visit:

www.autogard.com



American Autogard Corp.

Rockford, Illinois
Tel +1 815 229 3190
Fax +1 815 229 4615
sales.us@autogard.com

Autogard Kupplungen

Barntrup, Germany
Tel +49 (0) 5263 954960
Fax +49 (0) 5263 954969
info@autogard.de

Autogard Italy

Milano, Italy
Tel +39 02 92 592083
Fax +39 02 39 305616
info@autogard.it

Autogard Asia Pacific P/L

Melbourne, Australia
Tel +61 (0) 3 9532 0901
Fax +61 (0) 3 9532 1032
sales@autogard.com.au

Your Local Distributor



MMC 11/04