

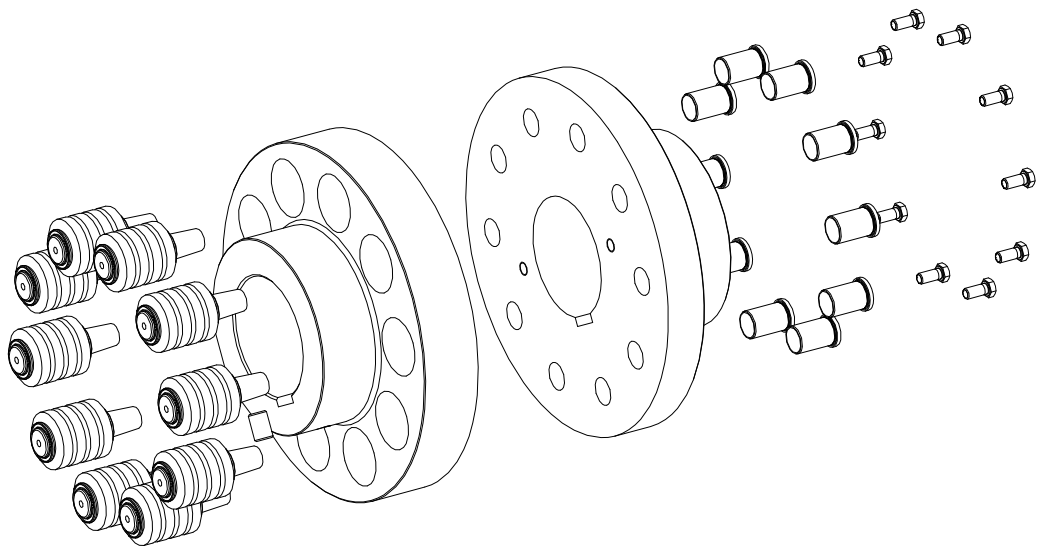

REVOLEX® KX / KX-D Pin & bush coupling

Flexible pin & bush couplings types
KX and KX-D and their combinations

according to directive 94/9/EC (ATEX 95)
for finish bored, pilot bored and unbored couplings



Type KX (taper pin design B)

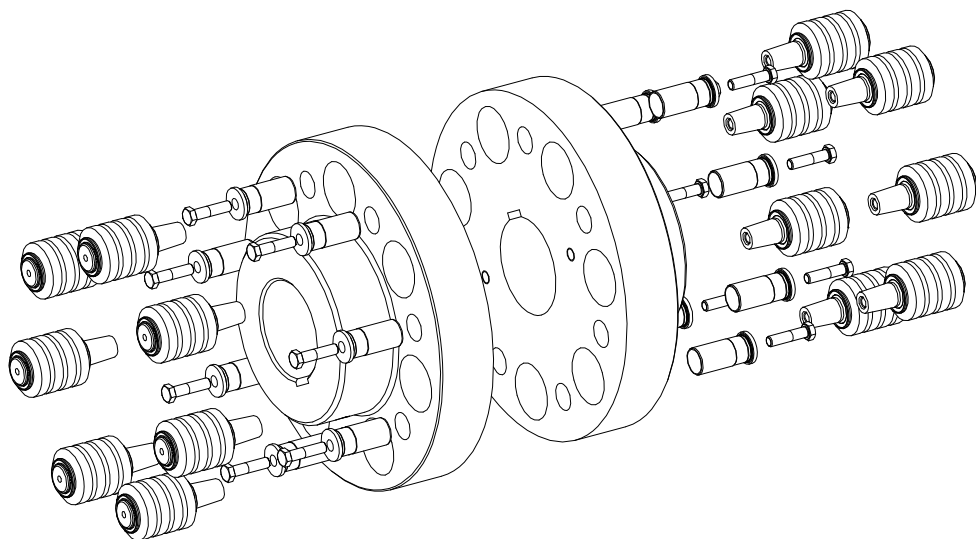

Type KX-D (taper pin design B)



REVOLEX® KX / KX-D is a torsionally flexible pin & bush coupling. It is able to compensate for shaft misalignment, for example caused by manufacturing inaccuracies, thermal expansion, etc.

Table of contents

1 Technical data

2 Advice

- 2.1 Coupling selection
- 2.2 General advice
- 2.3 Safety and advice symbols
- 2.4 General hazard warnings
- 2.5 Intended use





3 Storage

4 Assembly

- 4.1 Components of the couplings
- 4.2 Components of the pins
- 4.3 Assembly of the coupling (general)
- 4.4 Assembly of type KX
- 4.5 Assembly of type KX-D
- 4.6 Advice for finish bore
- 4.7 Displacements - alignment of the couplings
- 4.8 Spares inventory, customer service addresses

5 Enclosure A

Advice and instructions regarding the use in hazardous locations

- 5.1 Intended use in  hazardous locations
- 5.2 Inspection intervals for couplings in  hazardous locations
- 5.3 Standard values of wear
- 5.4 Permissible coupling materials in  hazardous locations
- 5.5  marking of coupling for hazardous locations
- 5.6 Start-up
- 5.7 Breakdowns, causes and elimination
- 5.8 Rating of danger of ignition
- 5.9 EC certificate of conformity according to the EC directive 94/9/EC dated March 23, 1994



1 Technical data

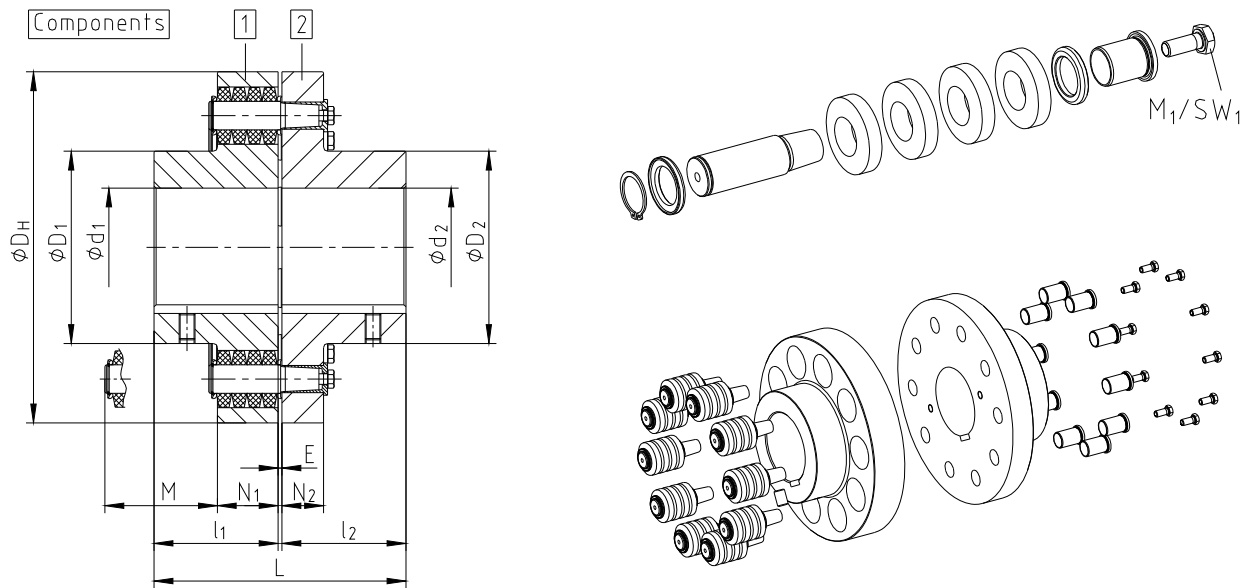

Illustration 1: REVOLEX® type KX (taper pin design B)

Table 1: Torques and dimensions – type KX (taper pin design B)

REVOLEX® KX															
Size	Torque ¹⁾ [Nm]		Cast iron		Steel		Dimensions [mm]								
			Max. speed ²⁾ [rpm]	Max. finish bore ³⁾ d ₁ /d ₂	Max. speed ²⁾ [rpm]	Max. finish bore ³⁾ d ₁ /d ₂	General								
	T _{KN}	T _{K max.}					L	l ₁ ; l ₂	E	D _H	D ₁	D ₂	N ₁	N ₂	M*
105	6485	12970	2000	110/125	3475	120/135	237	117	3	330	180	202	56	30	76
120	10080	21060	1800	125/145	3100	140/155	270	132	6	370	206	232	76	46	100
135	14030	28060	1600	140/150	2725	160/165	300	147	6	419	230	240	76	46	100
150	17960	35920	1450	160	2500	185	336	165	6	457	256	260	76	46	100
170	26360	52720	1250	180	2150	220	382	188	6	533	292	292	92	63	130
190	36160	72320	1100	205	1900	245	428	211	6	597	330	330	92	63	130
215	48160	96320	1000	230	1725	275	480	237	6	660	368	368	92	63	130
240	65740	131480	900	250	1550	310	534	264	6	737	407	407	122	76	170
265	91480	182960	800	285	1375	350	590	292	6	826	457	457	122	76	170
280	123530	247060	720	315	1225	385	628	311	6	927	508	508	122	76	170
305	152840	305680	675	330	1150	405	654	324	6	991	533	533	122	76	170
330	188470	376940	625	355	1075	435	666	330	6	1067	572	572	122	76	170
355	230110	460220	575	380	975	465	718	356	6	1156	610	610	122	76	170
370	302500	605000	535	450	900	550	770	382	6	1250	720	720	122	76	170

1) Standard material NBR (Perbunan) 80 ± 5 Shore A

* Drop-out center dimension required

2) Dynamic balancing required

3) Bores H7 with feather keyway according to DIN 6885, sheet 1 [JS9] and thread for setscrews on the keyway (see table 7)

Table 2: Pin – type KX (taper pin design B)

Size	105	120	135	150	170	190	215	240	265	280	305	330	355	370
Pin size	3	4		5			6							
M ₁ [mm]	M10	M12		M16			M24							
SW ₁ [mm]	17	19		24			36							
Tightening torque T _A [Nm]	67	115		290			970							



1 Technical data

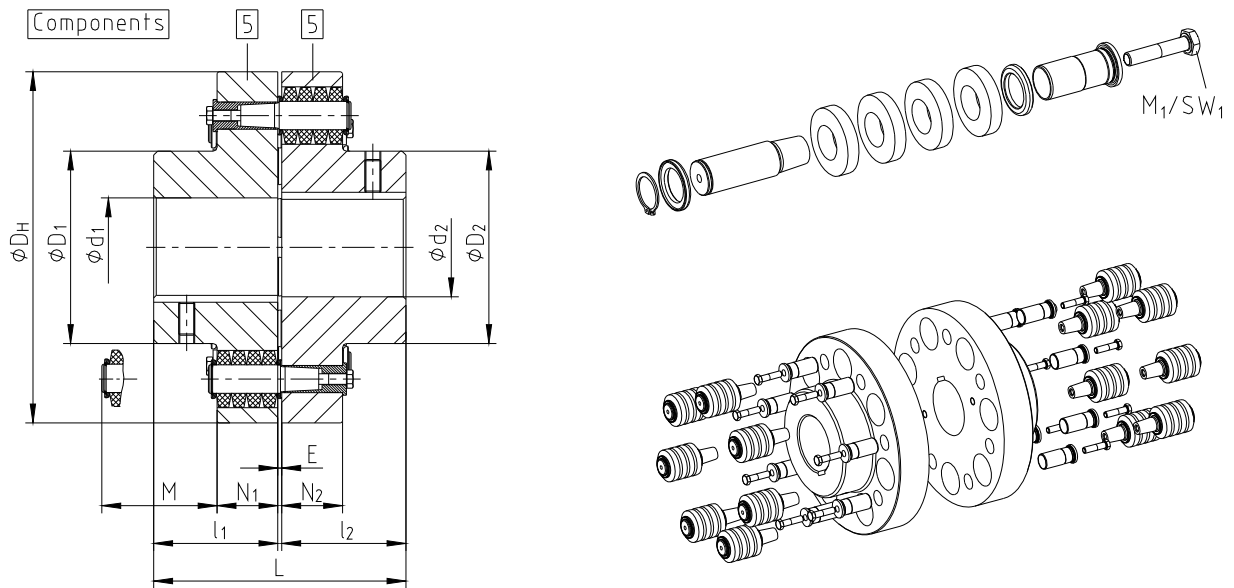

Illustration 2: REVOLEX®, type KX-D (taper pin design B)

Table 3: Torques and dimensions – type KX-D (taper pin design B)

REVOLEX® KX-D													
Size	Torque ¹⁾ [Nm]		Cast iron		Steel		Dimensions [mm]						
	T _{KN}	T _{K max.}	Max. speed ²⁾ [rpm]	Max. finish bore ³⁾ d ₁ /d ₂	Max. speed ²⁾ [rpm]	Max. finish bore ³⁾ d ₁ /d ₂	General						
							L	l ₁ ; l ₂	E	D _H	D ₁ , D ₂	N ₁ ; N ₂	M*
75	3800	7600	-	-	4500	90	193	95	3	255	136	56	76
85	5000	10000	-	-	4175	100	213	105	3	274	152	56	76
95	6600	13200	-	-	3825	110	227	112	3	298	168	56	76
105	8650	17300	2000	110	3475	120	237	117	3	330	180	56	76
120	14110	28220	1800	125	3100	140	270	132	6	370	206	76	100
135	18690	37380	1600	140	2725	160	300	147	6	419	230	76	100
150	23100	46200	1450	160	2500	185	336	165	6	457	256	76	100
170	36900	73800	1250	180	2150	220	382	188	6	533	292	92	130
190	48210	96420	1100	205	1900	245	428	211	6	597	330	92	130
215	61900	123800	1000	230	1725	275	480	237	6	660	368	92	130
240	920300	184060	900	250	1550	310	534	264	6	737	407	122	170
265	121900	243800	800	285	1375	350	590	292	6	826	457	122	170
280	158800	317600	720	315	1225	385	628	311	6	927	508	122	170
305	191060	382120	675	330	1150	405	654	324	6	991	533	122	170
330	251200	502400	625	355	1075	435	666	330	6	1067	572	122	170
355	300000	600000	575	380	975	450	721	356	9	1156	610	164	220
370	400000	800000	535	450	900	530	773	382	9	1250	720	164	220

1) Standard material NBR (Perbunan) 80 ± 5 Shore A

* Drop-out center dimension required

2) Dynamic balancing required

3) Bores H7 with feather keyway according to DIN 6885, sheet 1 [JS9] and thread for setscrews on the keyway (see table 7)

Table 4: Pin – type KX-D (taper pin design B)

Size	75	85	95	105	120	135	150
Pin size	3						4
M ₁ [mm]	M10						M12
SW ₁ [mm]	17						19
Tightening torque T _A [Nm]	67						115

Size	170	190	215	240	265	280	305	330	355	370
Pin size	5					6				
M ₁ [mm]	M16					M24				
SW ₁ [mm]	24					36				
Tightening torque T _A [Nm]	290					970				

Please observe protection note ISO 16016.	Drawn:	13.05.14 Pz/At	Replaced for:	KTR-N dated 28.05.10
	Verified:	27.05.14 Pz	Replaced by:	



1 Technical data

The rated torques apply under the following conditions:

- Use of original KTR components made of Perbunan or natural rubber in 80 Shore
- Permanent operation
- Up to 25 torque shocks (up to 3 times the rated torque) per hour
- Adhering to the misalignment figures mentioned
- Operation within the permissible temperature range taking into account the service factors for temperature
 - - 30 °C to + 80 °C with elastomers made of Perbunan (NBR)
 - - 50 °C to + 70 °C with elastomers made of natural rubber (NR)

2 Advice

2.1 Coupling selection



CAUTION!

For a long-lasting and failure-free operation of the coupling it must be selected according to the selection instructions (according to DIN 740 part 2) for the particular application (see REVOLEX® KX catalogue).

We would recommend balancing from a circumferential speed of 30 m/s.

If the operating conditions (performance, speed, modifications on engine and machine) change, the coupling selection must be reviewed again.

Please make sure that the technical data regarding torque refer to the elastomers only. The transmittable torque of the shaft-hub-connection must be reviewed by the customer and is subject to his responsibility.

For drives subject to torsional vibrations (drives with cyclic stress due to torsional vibrations) it is necessary to perform a torsional vibration calculation to ensure a reliable selection. Typical drives subject to torsional vibrations are e. g. drives with diesel engines, piston pumps, piston compressors etc. If requested, KTR will perform the coupling selection and the torsional vibration calculation.

2.2 General advice

Please read through these assembly instructions carefully before you start up the coupling. Please pay special attention to the safety instructions!



The **REVOLEX® KX / KX-D** coupling is suitable and approved for the use in hazardous locations. When using the coupling in hazardous locations please observe the special advice and instructions regarding safety in enclosure A.

The assembly instructions are part of your product. Please store them carefully and close to the coupling. The copyright for these assembly instructions remains with **KTR Kupplungstechnik GmbH**.

2.3 Safety and advice symbols



DANGER!

Danger of injury to persons.



CAUTION!

Damages on the machine possible.



ATTENTION!

Pointing to important items.



WARNING!

Hints concerning explosion protection.

Please observe protection note ISO 16016.	Drawn:	13.05.14 Pz/At	Replaced for:	KTR-N dated 28.05.10
	Verified:	27.05.14 Pz	Replaced by:	



2 Advice

2.4 General hazard warnings



DANGER!

With assembly, operation and maintenance of the coupling it has to be made sure that the entire drive train is secured against accidental switch-on. You may be seriously hurt by rotating parts. Please make absolutely sure to read through and observe the following safety indications.

- All operations on and with the coupling have to be performed taking into account "safety first".
- Please make sure to switch off the power pack before you perform your work on the coupling.
- Secure the power pack against accidental switch-on, e. g. by providing warning signs at the place of switch-on or removing the fuse for current supply.
- Do not reach into the operation area of the coupling as long as it is in operation.
- Please secure the coupling against accidental contact. Please provide for the necessary protection devices and covers.

2.5 Intended use

You may only assemble, operate and maintain the coupling if you

- have carefully read through the assembly instructions and understood them
- had technical training
- are authorized by your company

The coupling may only be used in accordance with the technical data (see table 1 to 4 in chapter 1). Unauthorized modifications on the coupling design are not admissible. We will not assume liability for any damage that may arise. In the interest of further development we reserve the right for technical modifications.

The **REVOLEX® KX / KX-D** described in here corresponds to the technical status at the time of printing of these assembly instructions.

3 Storage

The coupling hubs are supplied in preserved condition and can be stored at a dry and covered place for 6 - 9 months.

The features of the elastomer rings remain unchanged for up to 5 years with favourable storage conditions.



CAUTION!

The storage rooms must not include any ozone-generating devices like e. g. fluorescent light sources, mercury-vapour lamps or electrical high-voltage appliances.

Humid storage rooms are not suitable.

Please make sure that condensation is not generated. The best relative air humidity is less than 65 %.

Please observe protection note ISO 16016.	Drawn:	13.05.14 Pz/At	Replaced for:	KTR-N dated 28.05.10
	Verified:	27.05.14 Pz	Replaced by:	



4 Assembly

Generally the coupling is supplied in individual parts. Before assembly the coupling has to be inspected for completeness.

4.1 Components of the couplings

Components of REVOLEX®, type KX (taper pin design B)

Component	Quantity	Description
1 ¹⁾	1	Hub part 1
2 ¹⁾	1	Hub part 2
3a	see table 5	Pins KX complete (design B)
4	see table 5	KX bush
7 ²⁾		Setscrew DIN EN ISO 4029

1) Material and balancing condition on request of the customer

2) Axial fastening of the hub and tolerances of the shaft-hub-connections on request of the customer

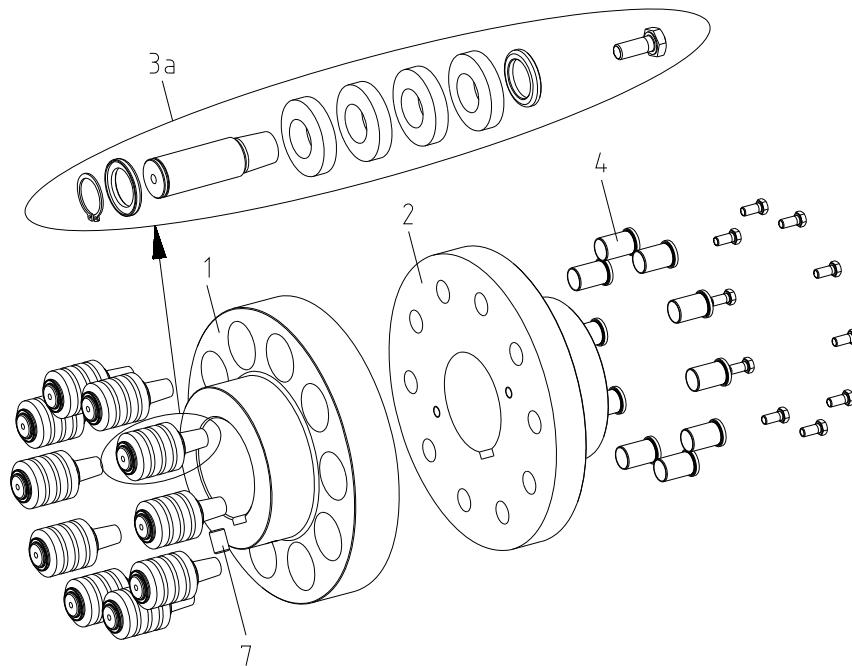

Illustration 3: REVOLEX® type KX (taper pin design B)

Table 5:

Number z of components	Size						
	105	120	135	150	170	190	215
3a, 4	12	10	12	14	10	12	14

Number z of components	Size						
	240	265	280	305	330	355	370
3a, 4	10	12	14	16	18	20	24



4 Assembly

4.1 Components of the couplings

Components of REVOLEX® type KX-D (taper pin design B)

Component	Quantity	Description
3c	see table 6	Pin KX-D complete (design B)
5 ¹⁾	2	Hub part 5
6	see table 6	KX-D bush
7 ²⁾		Setscrew DIN EN ISO 4029

1) Material and balancing condition on request of the customer

2) Axial fastening of the hub and tolerances of the shaft-hub-connections on request of the customer

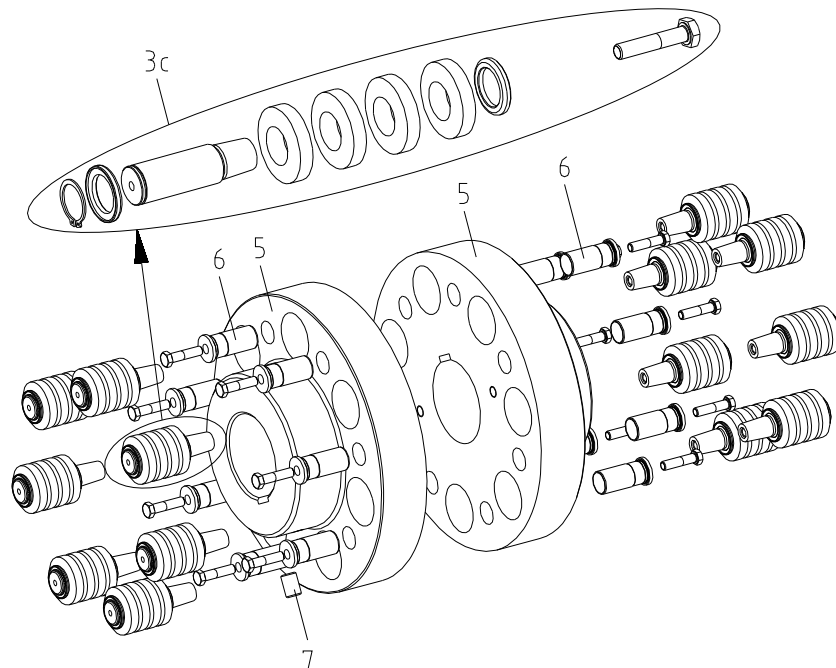

Illustration 4: REVOLEX® type KX-D (taper pin design B)

Table 6:

Number z of components	Size								
	75	85	95	105	120	135	150	170	190
3c, 6	10	12	14	16	14	16	18	14	16

Number z of components	Size								
	215	240	265	280	305	330	355	370	
3c, 6	18	14	16	18	20	24	26	30	



4 Assembly

4.2 Components of the pins

Components of complete pin KX (design B) - component 3a

Component	Quantity	Description
3.1b	1	Pin KX (design B)
3.2	4	Elastomer ring
3.3b	2	Disk
3.4a	1	Hexagon head screw DIN EN ISO 4014/4017
3.5	1	Circlip DIN 471

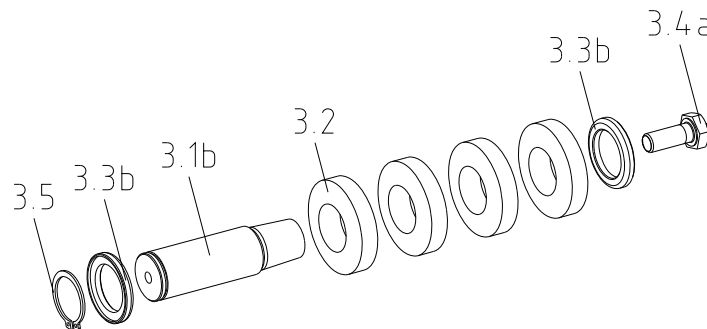

Illustration 5: Pin KX complete (design B)

Components of complete pin KX-D (design B) - component 3c

Component	Quantity	Description
3.1b	1	Pin KX-D (design B)
3.2	4	Elastomer ring
3.3b	2	Disk
3.4c	1	Hexagon head screw DIN EN ISO 4014/4017
3.5	1	Circlip DIN 471

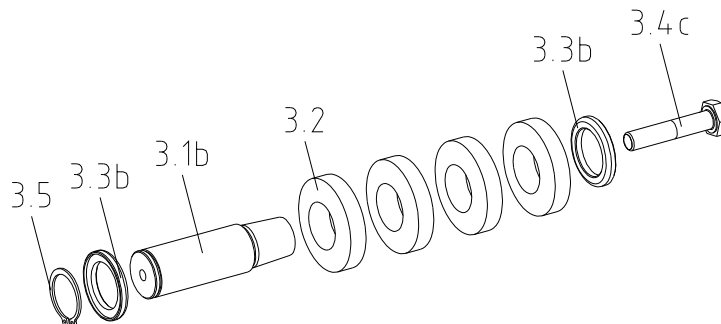

Illustration 6: Pin KX-D complete (design B)



4 Assembly

4.3 Assembly of the coupling (general)



ATTENTION!

We recommend to inspect bores, shaft, keyway and feather key for dimensional accuracy before assembly.

Heating the hubs lightly (approx. 80 °C) allows for an easier mounting on the shaft.



WARNING!

Please pay attention to the ignition risk in hazardous locations!



DANGER!

Touching the heated hubs causes burns.
Please wear safety gloves.



CAUTION!

With the assembly please make sure that the distance dimension E (see table 1 and 3) is observed so that the hubs are not in contact with each other during the operation.
Disregarding this advice may cause damage to the coupling.



CAUTION!

With the assembly of screw connections only those screws indicated by the manufacturer have to be used. When tightening the screws the torque indicated by the manufacturer has to be observed. The screws have to be secured against working loose (e. g. Loctite 243 average strength).



4.4 Assembly of type KX

- Drive the sleeves (component 4) into the bores of the hub part 2 (component 2) by light blows (see illustration 7).

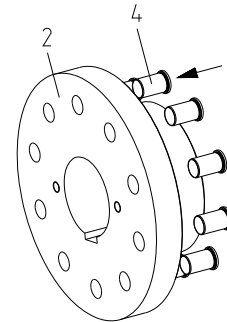

Illustration 7

- Please assemble the hubs on the shafts of the driving and driven side in a way that the flat faces of the coupling hubs are flush with the faces of the shafts (see illustration 8).

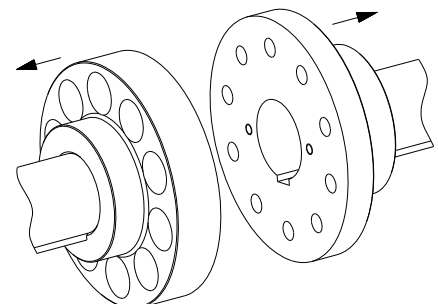

Illustration 8

Please observe protection note ISO 16016.	Drawn:	13.05.14 Pz/At	Replaced for:	KTR-N dated 28.05.10
	Verified:	27.05.14 Pz	Replaced by:	



4 Assembly

4.4 Assembly of type KX

- Shift the power packs in axial direction until the distance dimension E is achieved (see illustration 9).
- If the power packs are already firmly assembled, shifting the hubs axially on the shafts allows for adjusting the distance dimension E.
- Fasten the hubs by tightening the setscrews DIN EN ISO 4029 with a cup point (tightening torque see table 7).
- Align the coupling hubs in a way that the bores for the pins are flush.



CAUTION!
Please consider permissible shaft displacements from chapter 4.7!

- Insert the pins (component 3a) in the hub part 1 (component 1) (see illustration 10).
- Screw up the pins to the hexagon head screws (component 3.4a) and tighten them evenly to the tightening torques mentioned in table 2 by means of a torque key (see illustration 10).



CAUTION!
The screws have to be secured against working loose (e. g. Loctite 243 average strength).

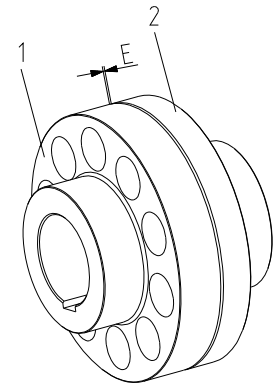

Illustration 9

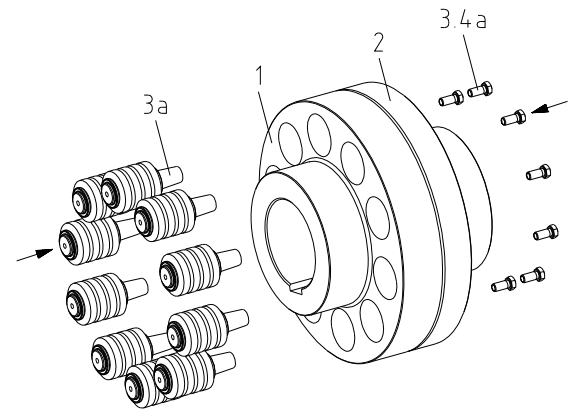

Illustration 10

4.5 Assembly of type KX-D

- Drive the sleeves (component 6) into the smaller bores of the hub part 5 (component 5) by light blows (see illustration 11).

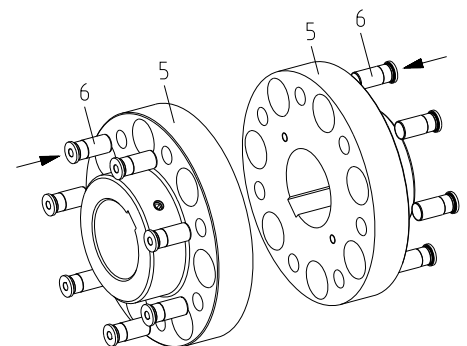

Illustration 11

- Please assemble the hubs on the shafts of the driving and driven side in a way that the flat faces of the coupling hubs are flush with the faces of the shafts (see illustration 12).

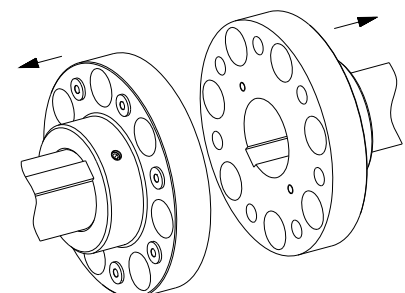

Illustration 12



4 Assembly

4.5 Assembly of type KX-D

- Shift the power packs in axial direction until the distance dimension E is achieved (see illustration 13).
- If the power packs are already firmly assembled, shifting the hubs axially on the shafts allows for adjusting the distance dimension E.
- Fasten the hubs by tightening the setscrews DIN EN ISO 4029 with a cup point (tightening torque see table 7).
- Align the coupling hubs in a way that the bores for the pins are flush.



CAUTION!
Please consider permissible shaft displacements from chapter 4.7!

- Insert the pins (component 3c) in the larger holes of the hub part 5 (component 5) (see illustration 14).
- Screw up the pins to the hexagon head screws (component 3.4c) and tighten them evenly to the tightening torques mentioned in table 4 by means of a torque key (see illustration 14).



CAUTION!
The screws have to be secured against working loose (e. g. Loctite 243 average strength).

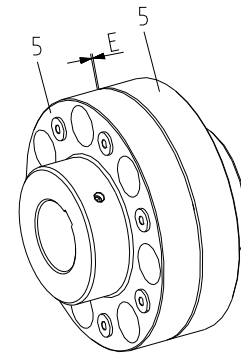

Illustration 13

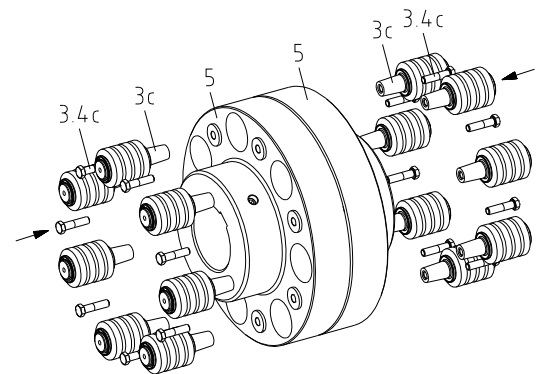

Illustration 14

4.6 Advice for finish bore



DANGER!
The maximum permissible bore diameters d (see table 1 to 4 in chapter 1 - technical data) must not be exceeded. If these figures are disregarded, the coupling may tear. Rotating particles may cause danger to life.

- Hub bores machined by the customer have to observe concentricity or axial runout, respectively (see illustration 15).
- Please make absolutely sure to observe the figures for $\varnothing d_{max}$.
- Carefully align the hubs when the finish bores are drilled.
- The bore tolerance should preferably be selected as per table 8.
- Please provide for a setscrew according to DIN EN ISO 4029 with a cup point or an end plate to fasten the hubs axially.

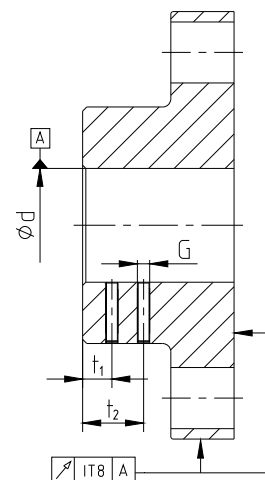

Illustration 15: Concentricity and axial runout

Please observe protection note ISO 16016.	Drawn: 13.05.14 Pz/At	Replaced for: KTR-N dated 28.05.10
	Verified: 27.05.14 Pz	Replaced by:



4 Assembly

4.6 Advice for finish bore



CAUTION!

The customer bears the sole responsibility for all machining processes performed subsequently on unbored or pilot bored as well as finish machined coupling components and spare parts. KTR does not assume any warranty claims resulting from insufficient re-machining.



WARNING!

KTR supplies unbored or pilot bored coupling components and spare parts only upon explicit request of the customer. These parts are additionally labelled with the symbol .

Table 7: Setscrews DIN EN ISO 4029

Size	75	85	95	105	120	135	150	170	190
Dimension G [mm]	M16	M16	M20	M20	M24	M24	M24	M24	M24
Dimension t ₁ [mm]	25	25	30	40	30	45	45	50	50
Dimension t ₂ [mm]	-	-	-	-	-	-	-	-	-
Tightening torque T _A [Nm]	80	80	140	140	220	220	220	220	220

Size	215	240	265	280	305	330	355	370
Dimension G [mm]	M24	M24	M24	M24	M24	M24	M24	M24
Dimension t ₁ [mm]	50	50	60	70	70	70	80	80
Dimension t ₂ [mm]	110	110	120	140	150	150	160	160
Tightening torque T _A [Nm]	220	220	220	220	220	220	220	220

Table 8: Recommended fit pairs acc. to DIN 748/1

Bore [mm]		Shaft tolerance	Bore tolerance
above	up to		
	50	k6	H7
50		m6	(KTR standard)

If a feather key is intended to be used in the hub, it should correspond to the tolerance ISO JS9 (KTR standard) with normal operating conditions or ISO P9 with difficult operating conditions (frequently alternating torsional direction, shock loads, etc.). In this case the keyway should be flush with one of the hub bores for the pins. With axial fastening by setscrews the tapping should be located on the keyway.

The transmittable torque of the shaft-hub-connection must be reviewed by the customer and is subject to his responsibility.

Unbored/pilot bored hubs are supplied without balancing. If balancing is necessary subject to the application, it should be made on completion of the finish bore. The balancing bores have to be made in the positions marked in illustration 16.



CAUTION!

The balancing bores have to be made between the pin bores in every case.

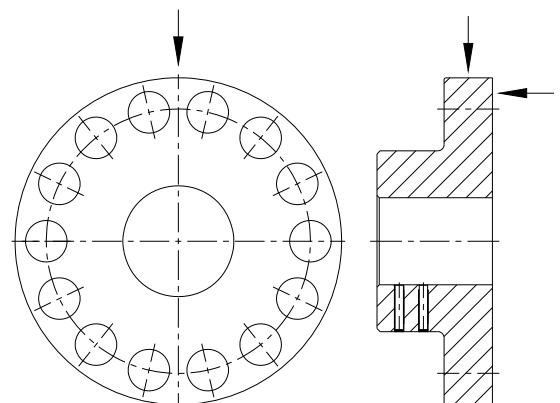

Illustration 16

Please observe protection note ISO 16016.	Drawn:	13.05.14 Pz/At	Replaced for:	KTR-N dated 28.05.10
	Verified:	27.05.14 Pz	Replaced by:	



4 Assembly

4.7 Displacements - alignment of the couplings

The **REVOLEX® KX / KX-D** compensates for displacements generated by the shafts to be combined as shown in table 9. Excessive misalignment may be generated by improper alignment, production tolerances, heat expansion, shaft bending, twisting of machine frames, etc.



CAUTION!

In order to ensure a long service life of the coupling and avoid dangers with the use in hazardous locations, the shaft ends must be accurately aligned.



Please absolutely observe the displacement figures indicated (see table 9). If the figures are exceeded, the coupling will be damaged.

The more accurate the alignment of the coupling, the longer is its service life.

If used in hazardous areas for the explosion group IIC (marking II 2GD c IIC T X), only half of the displacement figures (see table 9) are permissible.

Please note:

- The displacement figures specified in table 9 are maximum figures which must not arise in parallel. If radial and angular displacement occur at the same time, the sum of the displacement figures must not exceed ΔK_r or ΔK_w (see illustration 18).
- Please check with a dial gauge, ruler, feeler or laser measuring device whether the permissible displacement figures of table 9 can be observed.

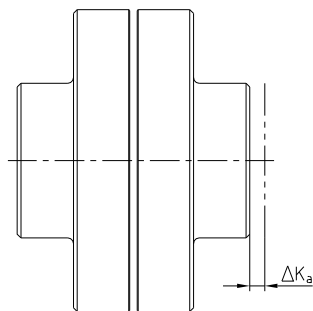

Axial displacements

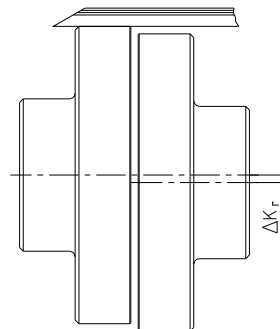

Radial displacements

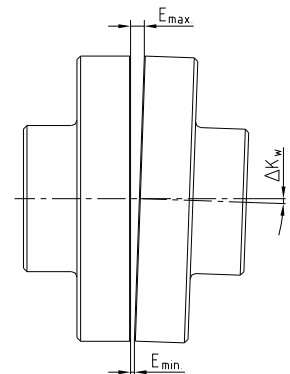

Angular displacements

$$L_{adm.} = L + \Delta K_a \text{ [mm]}$$

$$\Delta K_w = E_{max.} - E_{min.} \text{ [mm]}$$

Illustration 17: Displacements

Examples of the displacement combinations specified in illustration 18:

Example 1:

$\Delta K_r = 30 \%$

$\Delta K_w = 70 \%$

Example 2:

$\Delta K_r = 60 \%$

$\Delta K_w = 40 \%$

$$\Delta K_{total} = \Delta K_r + \Delta K_w \leq 100 \%$$

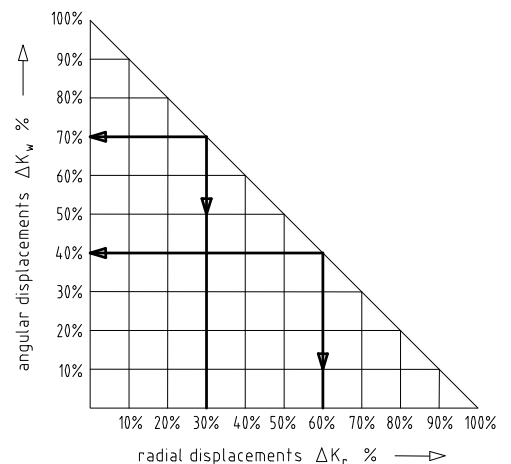

Illustration 18: Combinations of displacement

Please observe protection note ISO 16016.	Drawn:	13.05.14 Pz/At	Replaced for:	KTR-N dated 28.05.10
	Verified:	27.05.14 Pz	Replaced by:	



4 Assembly

4.7 Displacements - alignment of the couplings

Table 9: Displacement figures

Size	75	85	95	105	120	135	150	170	190
Max. axial displacement ΔK_a [mm]	± 1.5	± 1.5	± 1.5	± 2	± 2	± 2	± 2	± 2.5	± 2.5
Max. radial displacement ΔK_r [mm] or max. angular displacement ΔK_w [mm] with speed n [rpm]	250	0.95	1.10	1.10	1.2	1.3	1.4	1.5	1.7
	500	0.70	0.80	0.80	0.9	0.9	1.0	1.1	1.2
	750	0.60	0.65	0.65	0.7	0.8	0.8	0.9	1.0
	1000	0.50	0.55	0.55	0.6	0.7	0.7	0.8	0.9
	1500	0.40	0.45	0.45	0.5	0.5	0.6	0.6	0.7
	2000	0.35	0.40	0.40	0.4	0.5	0.5	0.5	0.6
3000	0.30	0.35	0.35	0.4	0.4	-	-	-	-

Size	215	240	265	280	305	330	355	370
Max. axial displacement ΔK_a [mm]	± 2.5	± 2.5	± 2.5	± 2.5	± 2.5	± 4	± 4	± 4
Max. radial displacement ΔK_r [mm] or max. angular displacement ΔK_w [mm] with speed n [rpm]	250	2.0	2.2	2.5	2.7	2.9	3.1	3.5
	500	1.4	1.6	1.7	1.9	2.0	2.2	2.5
	750	1.2	1.3	1.4	1.6	1.7	1.8	2.0
	1000	1.0	1.1	1.2	1.4	1.4	1.5	1.7
	1500	0.8	0.9	1.0	-	-	-	-
	2000	-	-	-	-	-	-	-
3000	-	-	-	-	-	-	-	

4.8 Spares inventory, customer service addresses

A basic requirement to ensure the operational readiness of the coupling is a stock of the most important spare parts on site.

Contact addresses of the KTR partners for spare parts and orders can be obtained from the KTR homepage at www.ktr.com.



ATTENTION!

KTR does not assume any liability or warranty for the use of spare parts and accessories which are not provided by KTR and for the damages which may incur as a result.

Please observe protection note ISO 16016.	Drawn: 13.05.14 Pz/At	Replaced for: KTR-N dated 28.05.10
	Verified: 27.05.14 Pz	Replaced by:



5 Enclosure A

Advice and instructions regarding the use in hazardous locations

Type KX: Hub/Pin/Hub
Type KX-D: Hub/Pin/Hub

5.1 Intended use in hazardous locations

Conditions of operation in hazardous locations

REVOLEX® KX / KX-D couplings are suitable for the use according to EC directive 94/9/EC.

The couplings may only be used if their materials are resistant to mechanical and/or chemical influences with the different operating conditions in a way that the explosion protection is not affected.
All metal components of a coupling half have to be connected with each other being electrically conductive and have to be earthed each by the shaft-hub-connection.

1. Industry (with the exception of mining)

- Equipment group II of category 2 and 3 (*coupling is not approved for equipment group 1*)
- Media class G (*gases, fogs, steams*), zone 1 and 2 (*coupling is not approved for zone 0*)
- Media class D (*dusts*), zone 21 and 22 (*coupling is not approved for zone 20*)
- Explosion group IIC (*explosion class IIA and IIB are included in IIC*)

Temperature class:

Temperature class	Ambient or operating temperature T_a	Max. surface temperature
T4, T3, T2, T1	- 30 °C to + 80 °C ¹⁾	+ 100 °C ²⁾
T5	- 30 °C to + 80 °C	+ 100 °C
T6	- 30 °C to + 65 °C	+ 85 °C

Explanation:

The maximum surface temperatures each result from the maximum permissible ambient or operating temperature T_a plus the maximum temperature increase ΔT of 20 K which has to be taken into account.

- 1) The ambient or operating temperature T_a is limited to + 80 °C due to the permissible permanent operating temperature of the elastomers used.
- 2) The maximum surface temperature of + 100 °C applies for the use in locations which are potentially subject to dust explosion, too.

2. Mining

Equipment group I of category M2 (coupling is not approved for equipment group M1).
Permissible ambient temperature - 30 °C to + 80 °C.

In addition the current national mining instructions which each apply for the application have to be respected for the use in mining.

Please observe protection note ISO 16016.	Drawn: 13.05.14 Pz/At	Replaced for: KTR-N dated 28.05.10
	Verified: 27.05.14 Pz	Replaced by:



5 Enclosure A

Advice and instructions regarding the use in  hazardous locations

5.2 Inspection intervals for couplings in  hazardous locations

Explosion group	Inspection intervals
3G 3D	For couplings which are classified in category 3G or 3D the operating and assembly instructions that are usual for standard operation apply. During the standard operation which has to be subject to the ignition risk analysis the couplings are free from any ignition source. Merely the temperature increase produced by self-heating and depending on the coupling type has to be considered: for REVOLEX® KX / KX-D: $\Delta T = 20 \text{ K}$
II 2G c IIB T4, T5, T6	An inspection of the torsional backlash and a visual inspection of the elastomer rings must be performed after 3,000 operating hours for the first time, at the latest after 6 months after start-up of the coupling. If you note insignificant or no wear on the elastomer ring upon this initial inspection, further inspections can each be performed after 6,000 operating hours or at the latest after 18 months, provided that the operating parameters remain the same. If you note significant wear during the initial inspection so that it would be recommendable to replace the elastomer ring, please specify the cause according to the table „Break-downs“, if possible. The maintenance intervals must be adjusted to the modified operating parameters without fail.
II 2G c IIC T4, T5, T6	An inspection of the torsional backlash and a visual inspection of the elastomer rings must be performed after 2,000 operating hours for the first time, at the latest after 3 months after start-up of the coupling. If you note insignificant or no wear on the elastomer ring upon this initial inspection, further inspections can each be performed after 4,000 operating hours or at the latest after 12 months, provided that the operating parameters remain the same. If you note significant wear during the initial inspection so that it would be recommendable to replace the elastomer ring, please specify the cause according to the table „Break-downs“, if possible. The maintenance intervals must be adjusted to the modified operating parameters without fail.



5 Enclosure A

Advice and instructions regarding the use in  hazardous locations

5.3 Standard values of wear

Reaching the limits for replacing depends on the operating conditions and the existing operating parameters.

With a twisting backlash $\geq \Delta s_{max.}$ in mm or a wall thickness $X_{mind.}$ in mm the elastomer rings need to be replaced.



CAUTION!

In order to ensure a long service life of the coupling and avoid dangers with the use in hazardous locations, the shaft ends must be accurately aligned. Please absolutely observe the displacement figures indicated (see table 9). If the figures are exceeded, the coupling will be damaged.

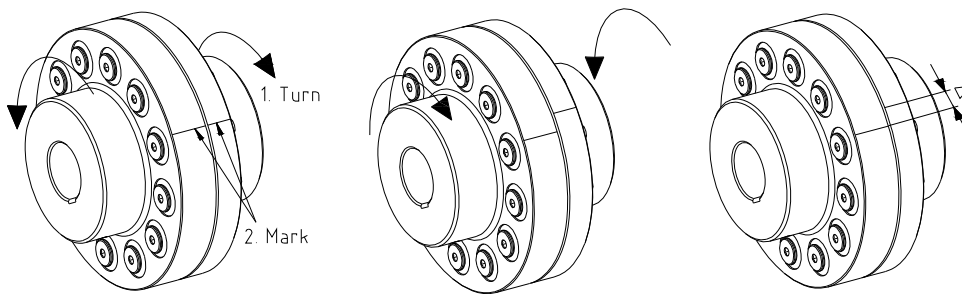

Illustration 19: Inspection of the limit of wear

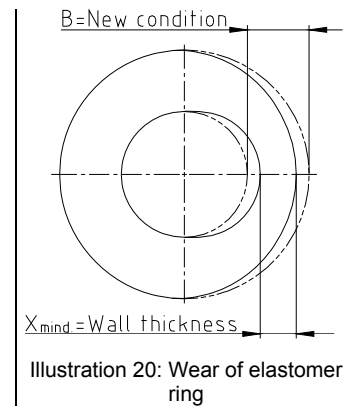

Illustration 20: Wear of elastomer ring

Table 10:

Size	Limits of wear [mm]				Size	Limits of wear [mm]			
	Diameter of elastomer	New condition B	Wall thickness $X_{mind.}$	Torsional backlash $\Delta s_{max.}$		Diameter of elastomer	New condition B	Wall thickness $X_{mind.}$	Torsional backlash $\Delta s_{max.}$
75	50.0	12.25	8.6	5	215	85.5	21.15	14.8	9
85	50.0	12.25	8.6	5	240	113.7	27.65	19.4	11
95	50.0	12.25	8.6	5	265	113.7	27.65	19.4	11
105	50.0	12.25	8.6	5	280	113.7	27.65	19.4	11
120	63.0	16.15	11.3	6	305	113.7	27.65	19.4	11
135	63.0	16.15	11.3	6	330	113.7	27.65	19.4	11
150	63.0	16.15	11.3	6	355	113.7	27.65	19.4	11
170	85.5	21.15	14.8	9	370	113.7	27.65	19.4	11
190	85.5	21.15	14.8	9					

5.4 Permissible coupling materials in  hazardous locations

In the explosion groups **IIA**, **IIB** and **IIC** the following materials may be combined:

- EN-GJL-250 (GG 25)
- EN-GJS-400-15 (GGG 40)

Semi-finished products of aluminium with a magnesium share of up to 7.5% and a yield point of $R_{p0.2} \geq 250 \text{ N/mm}^2$ are permitted for the use in hazardous locations.

Aluminium diecast is generally excluded for hazardous locations.

Please observe protection note ISO 16016.	Drawn:	13.05.14 Pz/At	Replaced for:	KTR-N dated 28.05.10
	Verified:	27.05.14 Pz	Replaced by:	



5 Enclosure A

Advice and instructions regarding the use in  hazardous locations

5.5 marking of coupling for hazardous locations

Couplings for the use in explosion-proof areas are marked fully or in part on at least one component each for the permissible operating conditions. The pins with elastomer rings are not marked.

Short labelling:
(standard)





II 2GD c IIC T X/I M2 c X

Complete labelling:



II 2G c IIC T6 resp. T5 - $30\text{ °C} \leq T_a \leq +65\text{ °C}$ resp. $+80\text{ °C}$
II 2D c T 100 °C /I M2 c - $30\text{ °C} \leq T_a \leq +80\text{ °C}$

The labelling with explosion group IIC includes the explosion groups IIA and IIB.

If the symbol  was stamped in addition to , the coupling component was supplied unbored or pilot bored by KTR.

5.6 Start-up

Before start-up of the coupling, please inspect the tightening of the setscrews in the hubs, the alignment and the distance dimension E and adjust, if necessary, and also inspect all screw connections for the tightening torques specified, dependent on the type of coupling.



If used in hazardous locations the setscrews to fasten the hubs as well as all screw connections must be secured against working loose additionally, e. g. conglomerating with Loctite (average strength).

Finally the coupling protection against accidental contact must be fitted.

The cover must be electrically conductive and included in the equipotential bonding. Bellhousings (magnesium share below 7.5 %) made of aluminium and damping rings (NBR) can be used as connecting element between pump and electric motor. The cover may only be taken off with standstill of the unit.

During operation of the coupling, please pay attention to

- different operating noise
- vibrations occurring.

If the couplings are used in locations subject to dust explosion and in mining the user must make sure that there is no accumulation of dust in a dangerous volume between the cover and the coupling. The coupling must not operate in an accumulation of dust.

For covers with unlocked openings on the top face no light metals must be used if the couplings are used as equipment of equipment group II (*if possible, from stainless steel*).

If the couplings are used in mining (equipment group I M2), the cover must not be made of light metal. In addition, it must be resistant to higher mechanical loads than if it is used as equipment of equipment group II.

The minimum distance „Sr“ between the protection device and the rotating parts must at least correspond to the figures mentioned below.

Please observe protection note ISO 16016.	Drawn:	13.05.14 Pz/At	Replaced for:	KTR-N dated 28.05.10
	Verified:	27.05.14 Pz	Replaced by:	



5 Enclosure A

Advice and instructions regarding the use in  hazardous locations

5.6 Start-up

If the protection device is used as cover, regular openings complying with the explosion protection demands can be made that must not exceed the following dimensions:

Openings	Cover [mm]		
	Top side	Lateral components	Distance „Sr“
Circular - max. diameter	4	8	≥ 10
Rectangular - max. lateral length	4	8	≥ 10
Straight or curved slot - max. lateral length/height	not permissible	8	≥ 20



CAUTION!

If you note any irregularities with the coupling during operation, the drive unit must be switched off immediately. The cause of the breakdown must be specified by means of the table „Breakdowns“ and if possible, be eliminated according to the proposals. The potential breakdowns mentioned can be hints only. To find out the cause all operating factors and machine components must be considered.

Coupling coating:



If coated (priming, painting etc.) couplings are used in hazardous locations, the requirements on conductivity and coating thickness must be considered. In case of paintings up to 200 µm electrostatic load does not have to be anticipated. Multiple coatings that are thicker than 200 µm are prohibited for explosion group IIC.

5.7 Breakdowns, causes and elimination

The below-mentioned failures may result in a use of the **REVOLEX® KX / KX-D** coupling other than intended. In addition to the specifications given in these operating and assembly instructions please make sure to avoid these failures.

The errors listed can only be clues to search for the failures. When searching for the failure the adjacent components must generally be included.



If used other than intended the coupling can become a source of ignition. EC directive 94/9/EC requires special care by the manufacturer and the user.

General failures with use other than intended:

- Important data for the coupling selection were not forwarded.
- The calculation of the shaft-hub-connection was not considered.
- Coupling components with damage occurred during transport are assembled.
- If the heated hubs are assembled, the permissible temperature is exceeded.
- The clearance of the components to be assembled is not coordinated with one another.
- Tightening torques have been fallen below/exceeded.
- Components are mixed up by mistake/assembled incorrectly.
- A wrong or no pin/elastomer ring is inserted in the coupling.
- No original **KTR** parts (purchased parts) are used.
- Old/already worn out elastomer rings or elastomer rings stored for too long are used.
- The coupling used/the coupling protection used is not suitable for the operation in hazardous areas and does not correspond to EC directive 94/9/EC, respectively.
- Maintenance intervals are not observed.

Please observe protection note ISO 16016.	Drawn:	13.05.14 Pz/At	Replaced for:	KTR-N dated 28.05.10
	Verified:	27.05.14 Pz	Replaced by:	



5 Enclosure A

Advice and instructions regarding the use in  hazardous locations

5.7 Breakdowns, causes and elimination

Breakdowns	Causes	Elimination
Different operating noise and/or vibrations occurring	Misalignment	<ol style="list-style-type: none"> 1) Set the unit out of operation 2) Eliminate the reason for the misalignment (e. g. loose foundation bolts, breaking of the engine mount, heat expansion of unit components, modification of the mounting dimension E of the coupling) 3) Inspection of wear see item inspection
	Wear of elastomers	<ol style="list-style-type: none"> 1) Set the unit out of operation 2) Disassemble the coupling and remove remainders of the elastomer ring/pin 3) Inspect coupling components and replace coupling hubs that are damaged 4) Generally assemble new elastomer rings with new pins 5) Assemble coupling components 6) Inspect alignment, adjust if necessary
	Thread for setscrews for axial fastening of hubs working loose	<ol style="list-style-type: none"> 1) Set the unit out of operation 2) Inspect alignment of coupling 3) Tighten the thread for setscrews to secure the hubs and secure against working loose 4) Inspection of wear see item inspection
Fracture of hub	Fracture of hub due to high impact energy/overload	<ol style="list-style-type: none"> 1) Set the unit out of operation 2) Replace complete coupling 3) Find out the reason for overload 4) Inspect alignment
	Operating parameters do not correspond to the performance of the coupling	<ol style="list-style-type: none"> 1) Set the unit out of operation 2) Review the operating parameters and select a larger coupling (consider mounting space) 3) Assemble new coupling size 4) Inspect alignment
	Operating error of the unit	<ol style="list-style-type: none"> 1) Set the unit out of operation 2) Replace complete coupling 3) Inspect alignment 4) Instruct and train the service staff



5 Enclosure A

Advice and instructions regarding the use in  hazardous locations

5.7 Breakdowns, causes and elimination

Breakdowns	Causes	Elimination
Early wear of elastomers	e. g. contact with aggressive liquids/oils, ozone influence, too high/low ambient temperatures etc. causing a physical modification of the elastomer rings	<ol style="list-style-type: none"> 1) Set the unit out of operation 2) Disassemble the coupling and remove remainders of the elastomer ring/pin 3) Inspect coupling components and replace coupling hubs that are damaged 4) Generally assemble new elastomer rings with new pins 5) Assemble coupling components 6) Inspect alignment, adjust if necessary 7) Make sure that further physical modifications of the pins are excluded
	ambient/contact temperatures which are too high for the elastomer ring, max. permissible - 30 °C/+ 80 °C	<ol style="list-style-type: none"> 1) Set the unit out of operation 2) Disassemble the coupling and remove remainders of the elastomer ring/pin 3) Inspect coupling components and replace coupling hubs that are damaged 4) Generally assemble new elastomer rings with new pins 5) Assemble coupling components 6) Inspect alignment, adjust if necessary 7) Inspect and adjust ambient/contact temperature
Early wear of pins (hardening/embrittlement of the pin elastomer)	Vibrations of drive	<ol style="list-style-type: none"> 1) Set the unit out of operation 2) Disassemble the coupling and remove remainders of the elastomer ring/pin 3) Find out the reason for vibrations 4) Inspect coupling components and replace coupling hubs that are damaged 5) Generally assemble new elastomer rings with new pins 6) Assemble coupling components 7) Inspect alignment, adjust if necessary



If you operate with worn elastomer rings (see item 5.3) and with subsequent contact of metal parts a due operation meeting the explosion protection requirements and acc. to EC standard 94/9/EC is not ensured.



5 Enclosure A

Advice and instructions regarding the use in  hazardous locations

5.8 Rating of danger of ignition

Source of danger	Elimination
Inaccurate coupling assembly	With a rough error in assembly the two coupling flanges being opposite to each other might touch (e. g. with angular displacements exceeding the permissible tolerances by far) or the elastomers might be compressed exceeding their load limit (e. g. with impermissible radial displacement), but which may be avoided by a test run.
Hubs are working loose on the shafts	The tight connection of the shaft-hub-connection should be inspected in regular intervals by the operator and re-arranged, if necessary.
Friction of foreign substances on the coupling	The couplings need to be protected against contact by suitable protective devices (e. g. solid covers) in order to exclude friction of foreign substances on the couplings as a failure anticipated. The minimum distance between the protective device and rotating parts has to be defined in a way that even if the protection against contact is damaged (e. g. dents), no friction is generated on the rotating coupling. Moreover, when defining the distance deflections caused by vibrations of the shaft need to be taken into account. For the use of couplings in mining the protective device needs to be particularly solid to make sure that the damage which must not be excluded with the rough operating conditions (e. g. by impressing) does not generate trailing/friction on the coupling. Moreover, the protective devices in mining must not consist of light-weight metals. <i>The protective device for mining has to pass the shock test as per EN 13463-5:2003, section 13.3.2.1, table 2 according to the degree of mechanical danger "high" (impact energy 20 J). This fact needs to be observed by the user (e. g. mechanical engineer) or the operator of the couplings.</i>
Contact/impact of foreign substances on the coupling	If the coupling gets in contact with objects, mechanical sparks may be produced each depending on the material and the energy of impact by swinging and striking against other objects (e. g. objects made of light-weight metal or rusty iron). Since the couplings have to be equipped with protective devices by the user which may have openings (see rules for protection against contact by rotating parts) for a better heat dissipation by convection, the contact or striking of dangerous objects on or against the couplings may be excluded as an anticipated failure. For the protective device a material has to be used excluding the production of ignitable mechanical sparks as far as possible.
Dust deposit on couplings which are not dustproof all over	In order to ensure a troublefree normal operation even in an explosive dust atmosphere it has to be made sure that the couplings are inspected in regular intervals to be free from critical dust deposits (e. g. free from coating) and are not running in a dust accumulation. This needs to be observed particularly if the couplings are equipped with non-dustproof protective devices against contact. Moreover, in places of work which are subject to dust explosion as well as in mining a higher amount of wear of the elastomer rings has to be considered. The elastomer rings must not be worn off in a way that the pins slide brightly in the holes. The source of ignition „self-ignition and glowing of dust deposits“ cannot be assumed as an anticipated failure with a corresponding maintenance of the coupling. Here corresponding maintenance means that the couplings need to be inspected in regular intervals to make sure that they are free from dangerous dust deposits and are not running in a dust accumulation. The corresponding inspection and cleaning rules have to be determined by the operator. The interval has to be determined depending on the operating conditions and safety specifications of dust like temperature of self-ignition and glowing at one's own responsibility.



5 Enclosure A

Advice and instructions regarding the use in  hazardous locations

5.9 EC Certificate of conformity

EC Certificate of conformity

corresponding to EC directive 94/9/EC dated 23 March 1994
and to the legal regulations

The manufacturer - KTR Kupplungstechnik GmbH, D-48432 Rheine - states that the

REVOLEX® KX / KX-D couplings

in an explosion-proof design described in these assembly instructions correspond to article 1 (3) b) of directive 94/9/EC and comply with the general safety and health requirements according to enclosure II of directive 94/9/EC.

The REVOLEX® KX/KX-D flexible pin & bush coupling is in accordance with the specifications of directive 94/9/EC. One or several directives mentioned in the corresponding EC type examination certificate IBExU06ATEXB009 X were in part replaced by updated versions. KTR Kupplungstechnik GmbH being the manufacturer confirms that the product mentioned above is in accordance with the specifications of the new directives, too.

According to article 8 (1) of directive 94/9/EC the technical documentation is deposited with the institution:

IBExU
Institut für Sicherheitstechnik GmbH
Fuchsmühlenweg 7

09599 Freiberg

Rheine,
Place

13.05.2014
Date

i. V. 
Reinhard Wibbeling
Head of Engineering

i. V. 
Michael Brüning
Product Manager