



**Reception Desk**

Dual-level curved reception desk finished in laminate with stainless steel feature pillars and profiles counter supports supporting etched glass counter caps



**Counter detail**

Toughened sandblasted glass counter cap lit by integral LED uplights

Project:  
**BMW - Engine Plant**

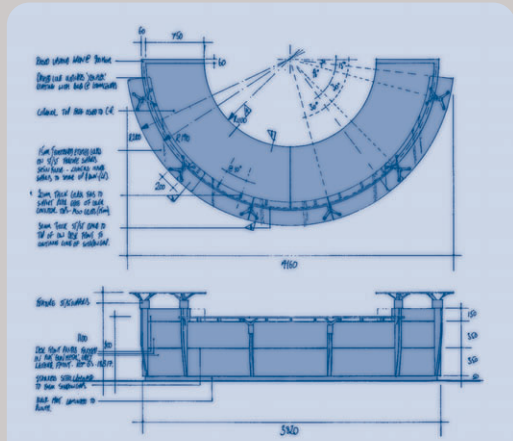

*“Clarke Rendall’s build quality ensured a highly engineered ‘feel’ whilst successfully embracing the BMW penchant for design understatement”*

**Building Manager, BMW Group**

*“With BMW, I knew from the word go that quality would be absolutely critical. I went to Clarke Rendall because I knew from experience - they would deliver”*

**Senior Designer**



t • 01908 391600

e • [salesupport@clarkerendall.com](mailto:salesupport@clarkerendall.com)

[www.clarkerendall.com](http://www.clarkerendall.com)