

System Technical Specification

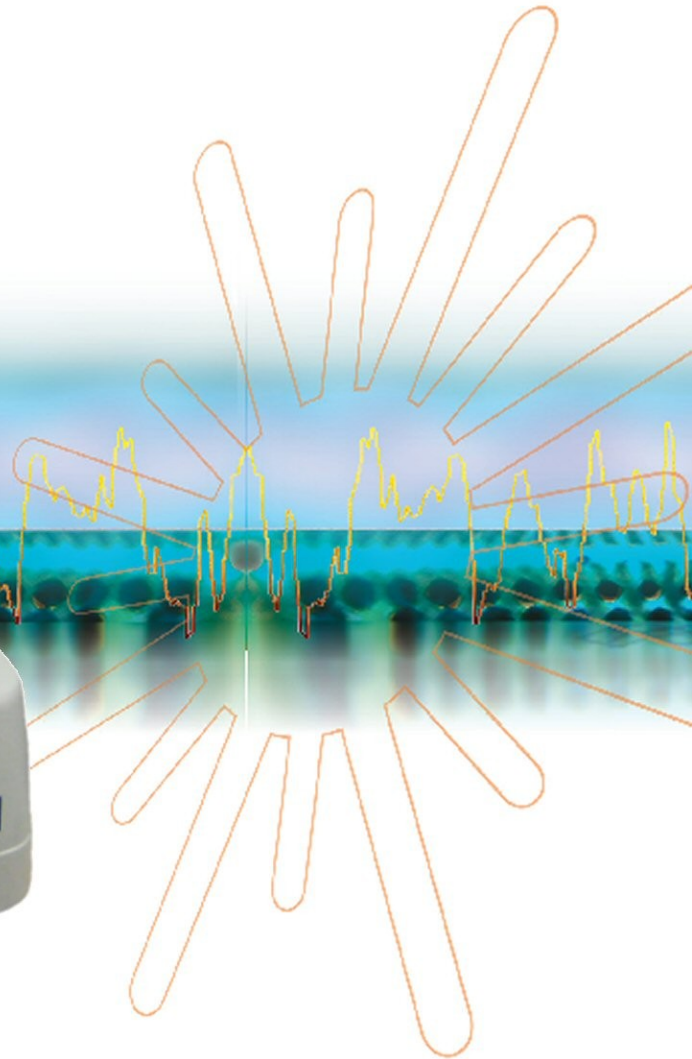

PROSCAN 2100

PRECISE NON-CONTACT 3D
SURFACE MEASUREMENT



Software Overview

- Colour 2D, 3D, X & Y axis presentation
- Auto or manual scaling
- Selectable view orientations
- Matrix scanning—multiple scans on single components, or automatic scanning of multiple samples in a fixture
- Customisable scripts and macros for easy processing of scan data
- Various filters including warpage, surface and spike filters
- Measurement functionality includes cross section, surface area, volume,

Exporting data

- Export data ASCII formats, ZZZZ... LF, XYZ LF and MATLAB

Datum setting

- 2D X & Y plane visual fitting
- 3 point user defined plane correction
- Auto plane correction
- 2 point scan rotation

Surface or form analysis

- Arithmetic Mean
- Ra - Average Roughness
- Rz (DIN) - Mean peak to valley height
- Rz (ISO) - Ten point height
- Rmax - Maximum peak to valley height
- Rp - Mean peak height
- Rq - Root mean square average roughness
- Rqm - Maximum peak height
- Rvm - Maximum valley depth
- R3z - Mean third peak to valley height
- Wt - Total waviness depth
- Pt - Total profile depth
- Nr - Normalised peak count
- Tpa - Material ratio
- D - Peak density
- S - Mean peak profile spacing
- Sm - Mean peak local spacing
- Lm - Sample length
- Coplanarity
- Warpage filter removes surface roughness to leave profile
- Surface filter removes surface profile to leave roughness
- Point editing
- Interpolation in X and/or Y axis
- Radius calculation
- Volume calculation
- Surface area calculation
- Cross section area calculation
- Contouring

Select the sensor for your application

Sensor Model	Resolution (µm)	Measuring Range (mm)	Stand off (mm)	Spot size (µm) nominal	Technology
S3/011	0.005	0.11	3.3	2 or 3.1	Chromatic
S11/03	0.012	0.3	11	2.6, 3.1 or 5.2	Chromatic
S13/1.1	0.025	1.1	12.7	4 or 8	Chromatic
S16/2.5	0.075	2.5	16.4	8 or 13.2	Chromatic
S29/10	0.280	10	29	16 or 22	Chromatic
S20/20	0.600	20	19.6	16 or 25.6	Chromatic
L25/2	0.03	2	24	35 - 80	Laser
L35/10	0.15	10	30	50 - 110	Laser
L50/20	0.3	20	40	60 - 160	Laser
L195/40	0.6	40	175	210 - 230	Laser
L70/50	0.8	50	45	80 - 215	Laser

Technical Specification

Scanner overall dimensions max (w x h x d)	740 x 542 x 835 mm
Scanner weight max	120 kg
Power supply overall dimensions	430 x 350 x 140 mm
Power supply weight	6.1 kg
PC Monitor (standard)	19" TFT flatscreen
Scanning plate size	380 x 280 mm
X and Y travel	150 x 100 mm
Z travel	100 mm
Electrical requirements	100 - 110 or 220 - 240 VAC, 50 - 60 Hz
Operating temperature	10 - 35 deg C
Step size X and Y (minimum)	0.1 μ m
Step size X and Y (maximum)	< maximum stage travel
Sample weight (maximum)	4 kg
Data collection rate (maximum) <small>depends on sensor & set-up</small>	10 kHz
Scanning speed (maximum) <small>depends on set-up</small>	80 mm/s
Maximum number of data points	64,000 per line
Scanning plate to sensor maximum clearance	100 mm nominal <small>depending on sensor</small>

Options

- Camera - available to help position small components or detect small features on a part. Supplied with separate control software and upgrade to 22" widescreen TFT monitor.
- Additional sensors - a wide range of sensors are available to cover all types of scanning work and all size of sample.
- Granite table - A sturdy and well manufactured steel framed table, complete with a granite top, ensures the optimal performance from the system is achievable.

Proscan Footprint

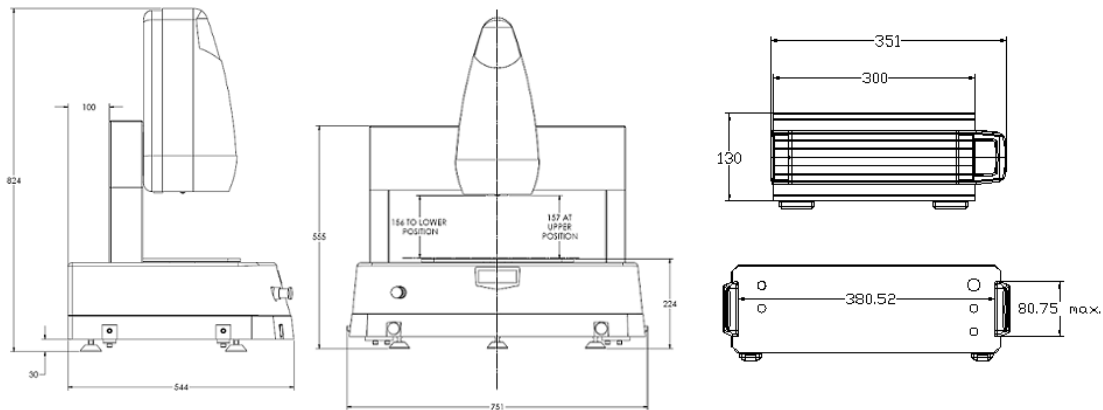

Scantron Industrial Products Ltd

Monarch Centre, Venture Way,
Taunton, Somerset, England, TA2 8DE

Telephone: +44 (0)1823 333343
Facsimile: +44 (0)1823 333684
E-mail: scantron@scantronltd.co.uk
website: www.scantronltd.co.uk

