



Sovereign











Pendants





The signature range from
Commercial Lighting Systems Ltd

Index

	Broadline <i>Suspended</i>	8
	Broadline IP65 <i>Suspended</i>	10
	Broadline Cylindrical <i>Suspended</i>	12
	Globe <i>Pendant</i>	16
	High Bay <i>Pendant</i>	20
	Round <i>Suspended</i>	24
	Ecoblade <i>Pendant</i>	28
	Opal Bowl <i>Pendant</i>	32
	Ring <i>Suspended</i>	36
	Shallow Drum <i>Suspended</i>	40

Modification

A sleek, minimalist form designed to accentuate the bold simplicity of the geometric profile.

For the ultimate clean aesthetic, choose blind end caps when specifying the Broadline Suspended range, and the remote driver option with the Broadline Cylindrical.

High Quality

Housed in extruded aluminium and manufactured in our UK factory, the Broadline range uses only components from well respected suppliers for best quality lighting and longevity.



Versatile

Suitable for a wide range of applications, with the IP65 version allowing for exterior installations.

Available in a range of sizes as well as bespoke lengths to suit. With our plug & socket connection design, longer lengths can be seamlessly joined together to provide limitless options.

Customisable

As well as our standard colour, output and CCT options, the standard Broadline Suspended can be cut in a range of angles and shapes to provide limitless geometric designs. Perfect for more dramatic, feature lighting solutions.

the
Broadline
Suspended
ranges



A sleek, minimalist form designed to accentuate the bold simplicity of the geometric profile.

For the ultimate clean aesthetic, choose blind end caps when specifying the Broadline Suspended range, and the remote driver option with the Broadline Cylindrical.

As well as our standard colour, output and CCT options, the standard Broadline Suspended can be cut in a range of angles and shapes to provide limitless geometric designs. Perfect for more dramatic, feature lighting solutions.



Product Family	Housing Colour	CCT	Suffix
S18620 584mm direct	/X5 Textured white	00 3000K	.8
S18622 1144mm direct	/X4 Textured black	01 4000K	
S18623 1424mm direct	/X2 Textured silver		
S18624 1704mm direct			
S18625 584mm direct/indirect			
S18627 1144mm direct/indirect			
S18628 1424mm direct/indirect			
S18629 1704mm direct/indirect			

EM, dimmable and control options available.
See page 42 for details.

Broadline

Suspended

LIGHT DETAILS - DIRECT

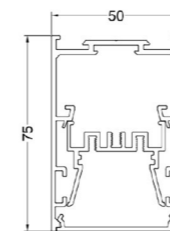
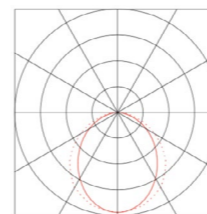

Length	CCT	Wattage	Lumens	Efficacy
584mm	3000K	15W	2350lm	161lm/W
584mm	4000K	15W	2470lm	169lm/W
1144mm	3000K	29W	4700lm	161lm/W
1144mm	4000K	29W	4940lm	169lm/W
1424mm	3000K	37W	5870lm	161lm/W
1424mm	4000K	37W	6170lm	169lm/W
1704mm	3000K	44W	7045lm	161lm/W
1704mm	4000K	44W	7410lm	169lm/W

A beautifully elegant linear profile system designed around the latest high performance Tridonic LLE LED modules.

Produced in high quality aluminium extruded profile, the Broadline Suspended luminaire can be supplied in standard lengths, or custom cut to suit. Also available as individual pendants or joined via plug & socket connection to provide "continuous" runs as required.

Supplied with standard or blind end caps (illustrated opposite), as well as an alternative prismatic diffuser. Get in touch to discuss full customisation options, including custom shapes and angles.

LIGHT DETAILS - DIRECT/INDIRECT

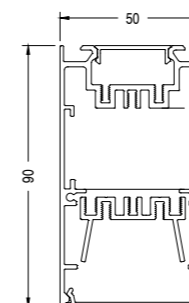
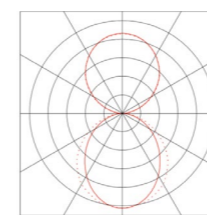

Length	CCT	Wattage	Lumens	Efficacy
584mm	3000K	22W	2350lm + 1174lm	161lm/W
584mm	4000K	22W	2470lm + 1235lm	169lm/W
1144mm	3000K	44W	4700lm + 2350lm	161lm/W
1144mm	4000K	44W	4940lm + 2470lm	169lm/W
1424mm	3000K	58W	5870lm + 3525lm	161lm/W
1424mm	4000K	58W	6170lm + 3705lm	169lm/W
1704mm	3000K	73W	7045lm + 4700lm	161lm/W
1704mm	4000K	73W	7410lm + 4940lm	169lm/W

Note: bespoke lengths available

TECHNICAL SPECIFICATIONS

IP rating	IP20
CRI	>80
Lamp Life	50,000 hours
Light Source	Tridonic LLE LED
Voltage	240V
Driver	Integrated high efficiency
LED Warranty	5 Years

HOUSING

Material	Extruded aluminium
Style	Standard / Blind end caps
Finish	Powder coated
Protection Rating	Class 1
Optics	Opal diffuser
Weight	2.5kg @ 600mm
Mounting	Wire suspension kit

Broadline Suspended



Pendants



Product Family		Housing Colour		CCT		Suffix
S18620IP	594mm direct	/X5	Textured white	00	3000K	.8
S18622IP	1154mm direct	/X4	Textured black	01	4000K	
S18623IP	1434mm direct	/X2	Textured silver			
S18624IP	1714mm direct					

EM, dimmable and control options available.
See page 42 for details.

Broadline IP65

Suspended

LIGHT DETAILS

Length	CCT	Wattage	Lumens	Efficacy
594mm	3000K	15W	2350lm	161lm/W
594mm	4000K	15W	2470lm	169lm/W
1154mm	3000K	29W	4700lm	161lm/W
1154mm	4000K	29W	4940lm	169lm/W
1434mm	3000K	37W	5870lm	161lm/W
1434mm	4000K	37W	6170lm	169lm/W
1714mm	3000K	44W	7045lm	161lm/W
1714mm	4000K	44W	7410lm	169lm/W

Note: bespoke lengths up to 2m available

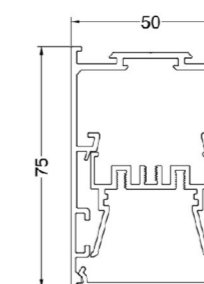
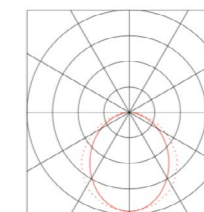

Matching the elegance of the Broadline Suspended, the Broadline IP65 Suspended extends the range to allow for exterior installations.

Produced in high quality aluminium extruded profile, the Broadline IP65 Suspended can be supplied in standard lengths, or custom cut to suit. Supplied c/w adjustable 3mtr wire suspension set.

TECHNICAL SPECIFICATIONS

IP rating	IP65
CRI	>80
Lamp Life	50,000 hours
Light Source	Tridonic LLE LED
Voltage	240V
Driver	Integrated high efficiency
LED Warranty	5 Years

HOUSING

Material	Extruded aluminium
Finish	Powder coated
Protection Rating	Class 1
Optics	Opal diffuser
Weight	2.5kg @ 600mm
Mounting	Wire suspension kit

Broadline IP65 Suspended



Pendants

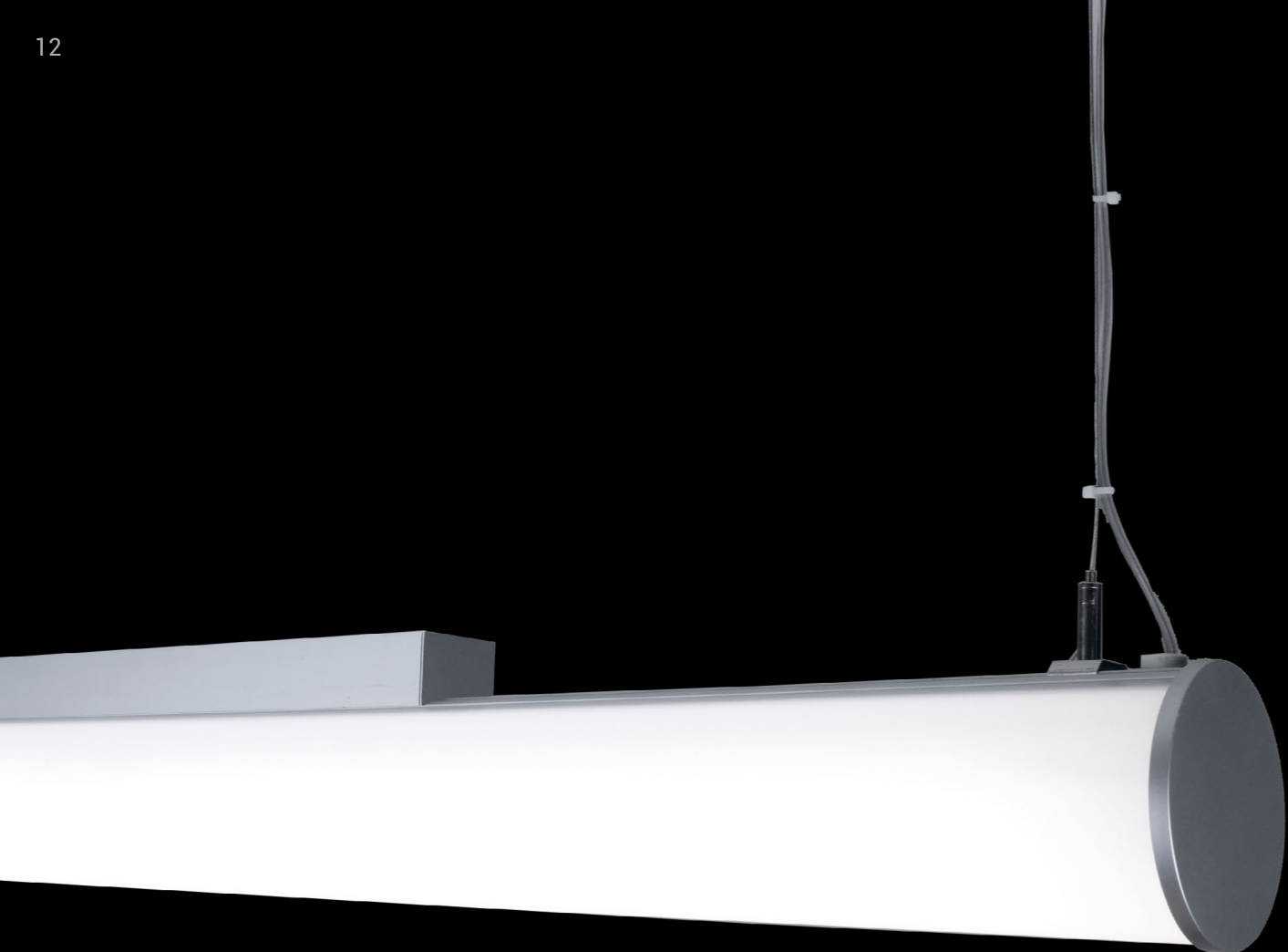

Product Family	Driver	Housing Colour	CCT	Suffix
S18672 594mm	Integrated	/00 Silver	00 3000K	.8
S18673 1154mm	R Remote		01 4000K	
S18674 1434mm				
S18675 1714mm				

EM, dimmable and control options available. See page 42 for details.

Broadline Cylindrical

Suspended

LIGHT DETAILS

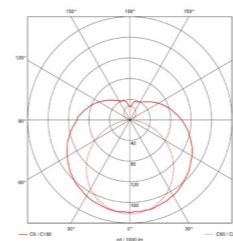

Length	CCT	Wattage	Lumens	Efficacy
584mm	3000K	15W	2350lm	161lm/W
584mm	4000K	15W	2470lm	169lm/W
1144mm	3000K	29W	4700lm	161lm/W
1144mm	4000K	29W	4940lm	169lm/W
1424mm	3000K	37W	5870lm	161lm/W
1424mm	4000K	37W	6170lm	169lm/W
1704mm	3000K	44W	7045lm	161lm/W
1704mm	4000K	44W	7410lm	169lm/W

Note: bespoke lengths available

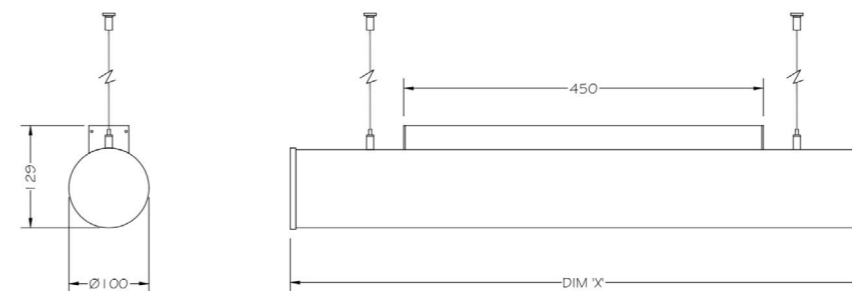

A beautifully stylish tubular luminaire, the Broadline Cylindrical range offers virtually all round illumination thanks to the wrap around diffuser design. Extending to 310° the diffusers allows the Tridonic LLE boards to provide high quality, even illumination.

Main spine and gear housing produced in high quality extruded & anodised aluminium with high transmission polycarbonate diffuser.

A choice of standard lengths are available with bespoke lengths up to 2.5mts also available to order. Standard versions fitted with integral high efficiency driver located within rear mounted aluminium housing, and can also be supplied with remote driver for a cleaner aesthetic line. Supplied c/w adjustable 3mtr wire suspension set.

TECHNICAL SPECIFICATIONS

IP rating	IP40
CRI	>80
Lamp Life	50,000 hours
Light Source	Tridonic LLE LED
Voltage	240V
Driver	High efficiency
LED Warranty	5 Years

HOUSING

Material	Extruded aluminium
Style	Remote / Integrated Driver
Finish	Powder coated
Protection Rating	Class 1
Optics	Polycarbonate diffuser
Weight	2.5kg @ 600mm
Mounting	Wire suspension kit

Broadline Cylindrical



Pendants

the
**Globe
 Pendant**
 range



Effortlessly suspended, the Sovereign Globe Pendant range provides a dramatic sense of weightlessness to interior environments.

Available in three sizes, these minimalist luminaires are ideal for a range of lighting designs; from discrete ambient illumination to dramatic, feature lighting with countless configurations.



Product Family	Size	Housing Colour	Version	Suffix
S98674 Globe Pendant	/280 Size 1	/05 White	00 3000K 280mm	.8
	/380 Size 2		01 4000K 280mm	
	/550 Size 3		02 3000K 380mm	
			03 4000K 380mm	
			04 3000K 550mm	
			05 4000K 550mm	

EM, dimmable and control options available. See page 42 for details.

Globe
Pendant

LIGHT DETAILS

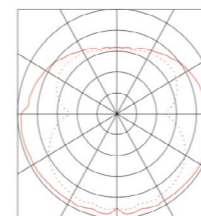

Size	CCT	Wattage	Lumens	Efficacy
Ø280mm	3000K	22W	3166lm	144lm/W
Ø280mm	4000K	22W	3396lm	154lm/W
Ø380mm	3000K	35W	4840lm	138lm/W
Ø380mm	4000K	35W	5040lm	144lm/W
Ø550mm	3000K	52W	7530lm	146lm/W
Ø550mm	4000K	52W	7947lm	153lm/W

This sleek and minimal opal LED luminaire boasts a multi faceted geartray design, ensuring optimum uniformity throughout while maintaining the pure globe form.

The Sovereign Globe Pendant is available in three sizes and uses the latest in LED technology for optimum efficiency and illumination.

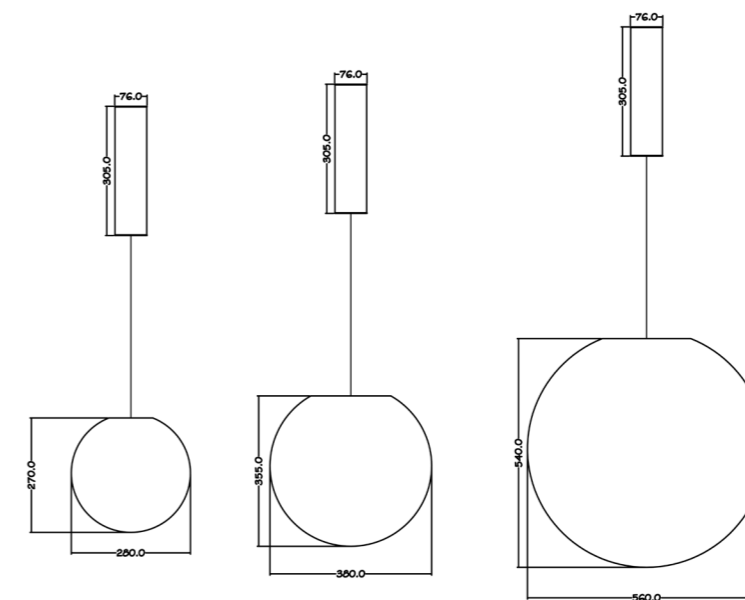

TECHNICAL SPECIFICATIONS

IP rating	IP40
CRI	>80
Lamp Life	50,000 hours
Light Source	Tridonic LLE + CLE
Voltage	240V
Driver	High efficiency
LED Warranty	5 Years

HOUSING

Material	Polyethylene / aluminium
Finish	Matt
Protection Rating	Class 1
Optics	Opal diffuser
Weight	Size 1 2.5KG / Size 2 3.5KG / Size 3 7KG
Mounting	Wire suspension kit

Globe Pendant



Pendants

the
**High Bay
Pendant**
range

A high performance decorative high bay, balancing a robust industrial-style housing with a delicate lightness provided by the prismatic shade.





Product Family	Housing Colour	Version	Suffix
S18332 High Bay	/05 White	22 3000K 20W	.8
	/04 Black	23 4000K 20W	
	/21 Silver	24 3000K 40W	
		25 4000K 40W	

EM, dimmable and control options available.
See page 42 for details.

High Bay

Pendant

LIGHT DETAILS

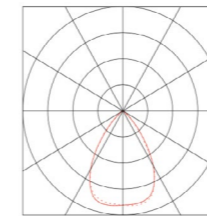

CCT	Wattage	Lumens	Efficacy
3000K	20W	2000lm	100lm/W
4000K	20W	2200lm	110lm/W
3000K	40W	4000lm	100lm/W
4000K	40W	4400lm	110lm/W

A high performance decorative high bay, incorporating a genuine Lexalite prismatic shade with extruded aluminium gear housing.

Utilising the very latest Tridonic/ Philips SLE LED module with passive heatsink, the Prismatic Pendant provides an aesthetic contrast between shade and gear housing.

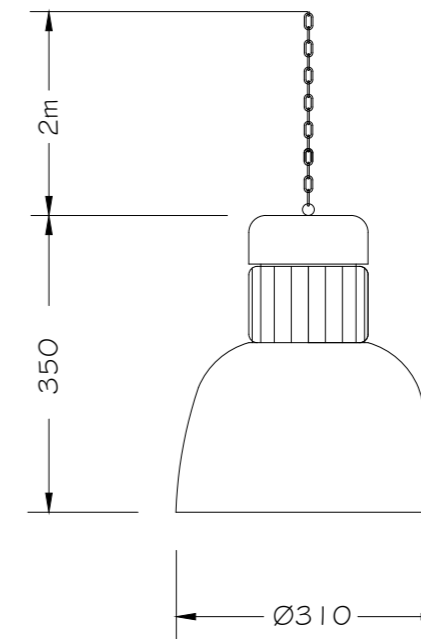

TECHNICAL SPECIFICATIONS

IP rating	IP20
CRI	>80
Lamp Life	50,000 hours
Light Source	CREE COB
Voltage	240V
Driver	High efficiency
LED Warranty	5 Years

HOUSING

Material	Aluminium
Finish	Powder coated
Protection Rating	Class 1
Optics	Acrylic prismatic
Weight	3.5KG
Mounting	Wire suspension kit

High Bay Pendant



Pendants

the
**Round
Suspended**
range

Taking the successful LED Panel concept to an exciting new level, these exceptionally slim circular units provide high levels of illumination with a pleasingly soft appearance.

With a main housing depth of just 25mm rising to a maximum of only 50mm for the discrete gear housing, these units give a "floating" appearance when suspended as pendants on our standard wire suspension system.





Product Family		Housing Colour		CCT	Suffix
S18636	Round Size 1	/05	White	00 3000K	.8
S18637	Round Size 2	/04	Black	01 4000K	
S18638	Round Size 3	/21	Silver		
S18639	Round Size 4				

EM, dimmable and control options available. See page 42 for details.

Round

Suspended

LIGHT DETAILS

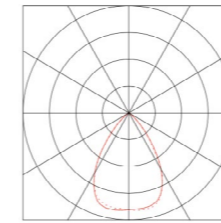

Size	CCT	Wattage	Lumens	Efficacy
Ø400mm	3000K	30W	2500lm	93lm/W
Ø400mm	4000K	30W	2700lm	90lm/W
Ø500mm	3000K	40W	3600lm	90lm/W
Ø500mm	4000K	40W	3800lm	90lm/W
Ø600mm	3000K	48W	4500lm	94lm/W
Ø600mm	4000K	48W	4800lm	100lm/W
Ø780mm	3000K	60W	5300lm	89lm/W
Ø780mm	4000K	60W	5400lm	90lm/W

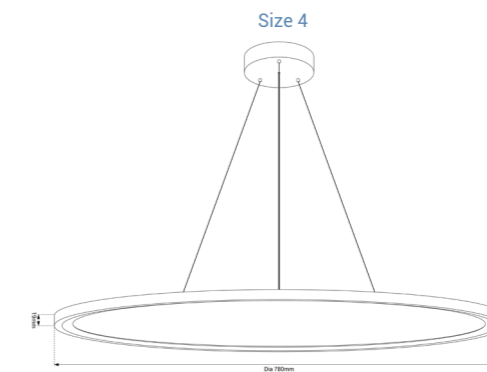
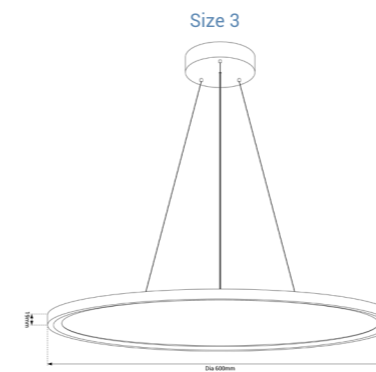
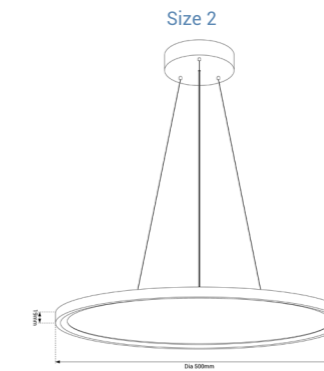
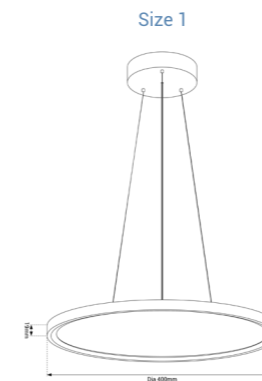

TECHNICAL SPECIFICATIONS

IP rating	IP40
CRI	>80
Lamp Life	50,000 hours
Light Source	Side Emitting SMD
Voltage	240V
Driver	High efficiency
LED Warranty	5 Years

HOUSING

Material	Spun aluminium
Finish	Powder coated
Protection Rating	Class 1
Optics	Opal diffuser
Weight	3.5kg - 6kg
Mounting	Wire suspension kit

Available in four sizes and outputs, the Sovereign Round Suspended range is supplied complete with standard high efficiency driver, but can also be specified with dimmable drivers to suit any dimming protocol.

EM versions also available, with all components located within the spun aluminium rear gear housing for ease of installation.

Round Suspended



Pendants

the
**Ecoblade
Pendant**
range

The Sovereign Ecoblade range is the result of extensive research and development by Commercial Lighting Systems. Matching a minimalist style with impressive efficiency and illumination makes the Ecoblade ideal for office environments.



Available also in Wall Mounted and Free Standing versions, the Ecoblade pendant is available as an uplight only or with an additional downlight option.



Product Family	Housing Colour	CCT	Suffix
S18641 Ecoblade Pendant	.X5 Textured white	00 3000K Uplight	.8
S18642 Ecoblade Slot Pendant	.X4 Textured black	01 4000K Uplight	
	.X2 Textured silver	02 3000K Up/Down	
		03 4000K Up/Down	

EM, dimmable and control options available. See page 42 for details.

Ecoblade

Pendant

LIGHT DETAILS - UP

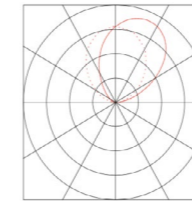

CCT	Wattage	Lumens	Efficacy
3000K	52W	8100lm	156lm/W
4000K	52W	8500lm	163lm/W

LIGHT DETAILS - UP/DOWN

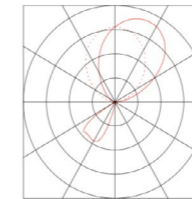

CCT	Wattage	Lumens	Efficacy
3000K	66W	10126lm	153lm/W
4000K	66W	10600lm	161lm/W

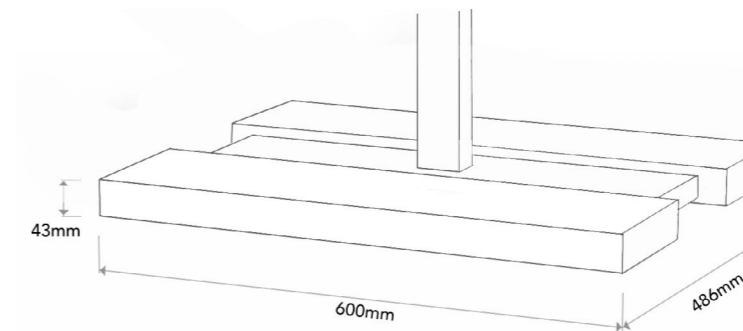

TECHNICAL SPECIFICATIONS

IP rating	IP40
CRI	>80
Lamp Life	50,000 hours
Light Source	Tridonic LLE LED
Voltage	240V
Driver	High efficiency
LED Warranty	5 Years

HOUSING

Material	Extruded aluminium
Style	Integrated Driver
Finish	Powder coated
Protection Rating	Class 1
Optics	Opal / Microprism
Weight	11.05kg
Mounting	Ceiling plate

An exceptionally high performance range of top quality pendant uplighters specifically designed around the latest high efficiency LED modules from Tridonic/ Osram, offering superb performance up to 163lm/W. Also available with illuminated slot to front of main housing as shown.

Main housing produced from extruded aluminium with integral passive thermal management. All versions supplied with Microprism diffuser for optimum light transmission and visual comfort.

Finished in textured polyester powder coat with standard finishes; White (.X5), Black (.X4), Anthracite (.X3), Silver (.X2) with other BS/RAL colours available to order.

Ecoblade Pendant



Pendants

the
Opal Bowl
range

A careful balance of contemporary and classic design. The vintage style perfectly suits historic and ornate environments such as museums, heritage buildings and churches.





Product Family	Housing Colour	Version	Suffix
S99239 Opal Bowl Pendant	/05 White	26 3000K 130W	.8
	/04 Black	27 4000K 130W	
	/21 Silver	28 3000K 156W	
		29 4000K 156W	
	24 3000K 182W		
	25 4000K 182W		

EM, dimmable and control options available. See page 42 for details.

Opal Bowl

Pendant

LIGHT DETAILS

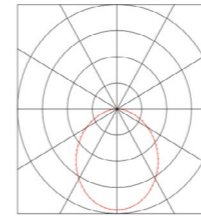

CCT	Wattage	Lumens	Efficacy
3000K	130W	11430lm + 7620lm	146lm/W
4000K	130W	12000lm + 8000lm	154lm/W
3000K	156W	1525lm + 7620lm	146lm/W
4000K	156W	16000lm + 8000lm	154lm/W
3000K	182W	19050lm + 7620lm	146lm/W
4000K	182W	20000lm + 8000lm	154lm/W

A modern chandelier-style pendant, providing both direct and indirect illumination. This classic design has been recently updated to the latest LED technology, ensuring the highest quality and efficiency on the market.

Optional spill-light facility to edge of upper housing with colour gel option (as shown).

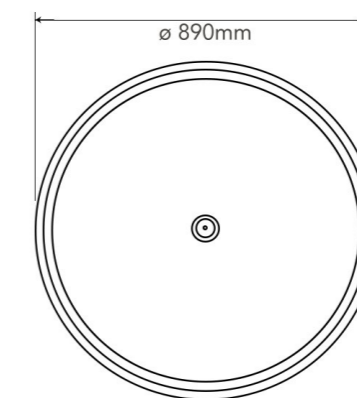
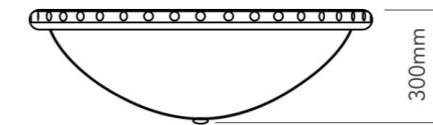

TECHNICAL SPECIFICATIONS

IP rating	IP40
CRI	>80
Lamp Life	50,000 hours
Light Source	Tridonic LLE LED
Voltage	240V
Driver	Integrated high efficiency
LED Warranty	5 Years

HOUSING

Material	Opal acrylic and aluminium
Style	Remote / Integrated Driver
Finish	Powder coated
Protection Rating	Class 1
Optics	Opal acrylic
Weight	5KG
Mounting	Wire suspension kit

Opal Bowl Pendant



Pendants

the
Ring
Suspended
range



A dramatic pendant available in four sizes, the Ring Suspended brings attention to architectural space. Ideal for retail, hospitality and lobby areas.



Product Family		Housing Colour		Version		Suffix
S18660	Ring Size 1	.05	White	00	3000K Direct	.8
S18661	Ring Size 2	.04	Black	01	4000K Direct	
S18662	Ring Size 3	.21	Silver	02	3000K Direct/Indirect	
S18663	Ring Size 4			03	4000K Direct/Indirect	

EM, dimmable and control options available.
See page 42 for details.

Ring
Suspended

LIGHT DETAILS - DIRECT

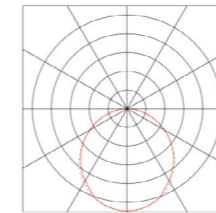

Size	CCT	Wattage	Lumens	Efficacy
Ø600mm	3000K	38W	3391lm	89lm/W
Ø600mm	4000K	38W	3391lm	90lm/W
Ø800mm	3000K	52W	5642lm	89lm/W
Ø800mm	4000K	52W	5652lm	89lm/W
Ø1100mm	3000K	79W	6782lm	90lm/W
Ø1100mm	4000K	79W	6782lm	90lm/W
Ø1450mm	3000K	99W	8478lm	90lm/W
Ø1450mm	4000K	99W	8478lm	90lm/W

LIGHT DETAILS - DIRECT/INDIRECT

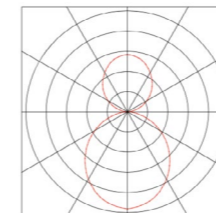

Size	CCT	Wattage	Lumens	Efficacy
Ø600mm	3000K	38W + 19W	3391lm + 1695lm	89lm/W
Ø600mm	4000K	38W + 19W	3391lm + 1695lm	90lm/W
Ø800mm	3000K	63W + 31.5W	5642lm + 2826lm	89lm/W
Ø800mm	4000K	63W + 31.5W	5652lm + 2826lm	89lm/W
Ø1100mm	3000K	75W + 37.5W	6782lm + 3391lm	90lm/W
Ø1100mm	4000K	75W + 37.5W	6782lm + 3391lm	90lm/W
Ø1450mm	3000K	94W + 47W	8478lm + 4286lm	90lm/W
Ø1450mm	4000K	94W + 47W	8478lm + 4286lm	90lm/W

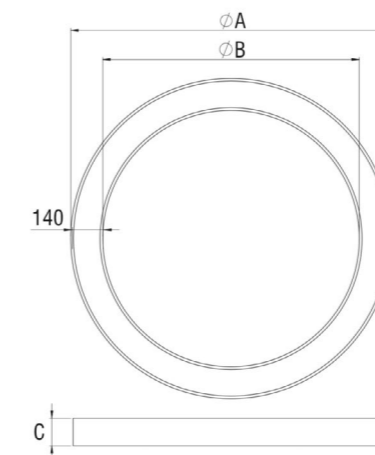

- Size 1**
 ØA = 600mm
 ØB = 450mm
 C Direct = 80mm,
 C Direct/Indirect = 120mm
- Size 2**
 ØA = 800mm
 ØB = 650mm
 C Direct = 80mm,
 C Direct/Indirect = 120mm
- Size 3**
 ØA = 1100mm
 ØB = 950mm
 C Direct = 80mm,
 C Direct/Indirect = 120mm
- Size 4**
 ØA = 1450mm
 ØB = 1300mm
 C Direct = 80mm,
 C Direct/Indirect = 120mm

HOUSING

Material	Extruded aluminium
Finish	Powder coated
Protection Rating	Class 1
Optics	Opal acrylic
Weight	5KG - 15KG
Mounting	Wire suspension kit

TECHNICAL SPECIFICATIONS

IP rating	IP20
CRI	>80
Lamp Life	50,000 hours
Light Source	OSRAM 2835
Voltage	240V
Driver	High efficiency
LED Warranty	5 Years

The Sovereign Suspended Ring is a sleek new range of suspended downlights and up/downlights. Housed in extruded aluminium, these high quality luminaires are matched by their beautifully uniform emission, utilising the latest LED technology.

Available in a range of sizes and outputs, as well as either Direct or Direct / Indirect.

Ring Suspended



Pendants

the
**Shallow
Drum**
range



An ideal pendant for providing uniform high output illumination in interior environments, particularly effective in high ceiling spaces. Available in five sizes to suit a range of applications.



Product Family	Housing Colour	CCT	Suffix
S18666 Shallow Drum Direct	.05 White	00 3000K 400mm	.8
S18667 Shallow Drum Direct/Indirect	.04 Black	01 4000K 400mm	
		02 3000K 600mm	
	03 4000K 600mm		
	04 3000K 800mm		
	05 4000K 800mm		
	06 3000K 1000mm		
	07 4000K 1000mm		
	08 3000K 1200mm		
	09 4000K 1200mm		

EM, dimmable and control options available. See page 42 for details.

Shallow Drum

Suspended

LIGHT DETAILS - DIRECT

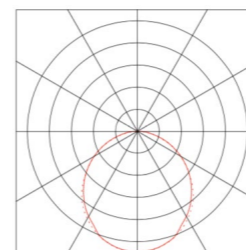

Size	Wattage	Lumens	Efficacy
Ø400mm	28W	2400lm	86lm/W
Ø600mm	50W	4250lm	85lm/W
Ø800mm	78W	6630lm	85lm/W
Ø1000mm	89W	8160lm	92lm/W
Ø1200mm	120W	10200lm	85lm/W

The Sovereign Suspended Shallow Drum is a sleek new range of suspended downlights. Housed in extruded aluminium, these high quality luminaires are matched by their beautifully uniform emission, utilising the latest LED technology and an opal diffuser.

Available in a range of sizes and outputs, as well as either Direct or Direct / Indirect.

LIGHT DETAILS - DIRECT/INDIRECT

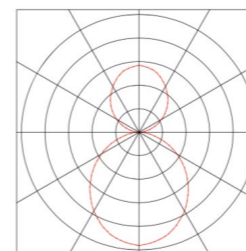

Size	Wattage	Lumens	Efficacy
Ø400mm	28W + 28W	4800lm	86lm/W
Ø600mm	50W + 50W	8500lm	86lm/W
Ø800mm	78W + 78W	13260lm	85lm/W
Ø1000mm	89W + 89W	16320lm	92lm/W
Ø1200mm	120W + 120W	20400lm	85lm/W

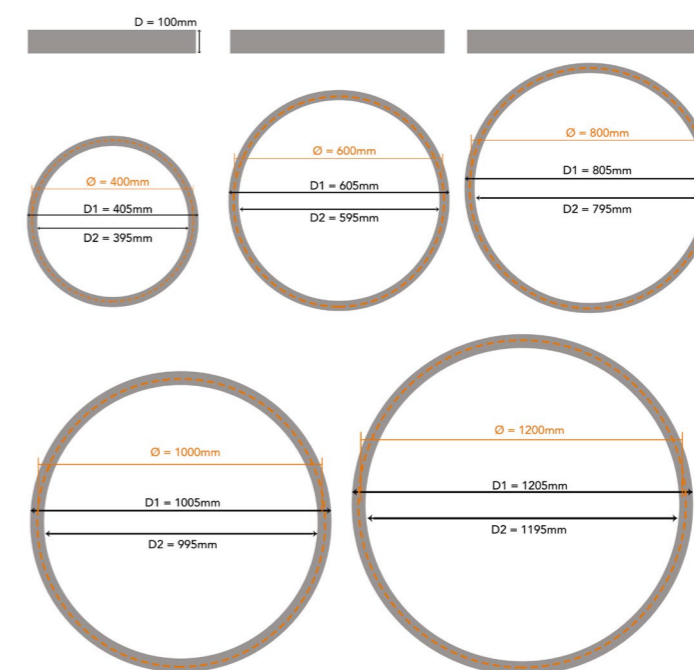

TECHNICAL SPECIFICATIONS

HOUSING		TECHNICAL SPECIFICATIONS	
Material	Extruded aluminium	IP rating	IP20
Finish	Powder coated	CRI	>80
Protection Rating	Class 1	Lamp Life	50,000 hours
Optics	Opal PMMA	Light Source	OSRAM 2835
Weight	5KG-10KG	CCT	3000K / 4000K
Mounting	Wire suspension kit	Voltage	240V
		Driver	Integrated high efficiency
		LED Warranty	5 Years

Shallow Drum



Pendants

Dimming, Emergency & Lighting Control

All of our Sovereign Pendants are available with a full range of EM and lighting control options. To specify products with our most popular lighting controls, insert the relevant code between the main product code and the suffix.

N.B.: When specifying control options without Emergency lighting options, include /10 under the Emergency selection (do not leave blank).

Product code	EM & Lighting Control Insert		Suffix
	Emergency	Control	
	/10 Non-EM	0 On / off	.8
	/11 Non maintained EM	1 1-10V dimming	
	/14 Maintained 3HR EM	2 DALI dimming	
	/16 DALI self test EM	5 Switch dim	
		6 DMX	
		7 Bluetooth	

Example: **S18667.X503.8**
Shallow Drum Downlight / Textured white / 4000K 600mm

S18667.X503/112
Shallow Drum Downlight / Textured white / 4000K 600mm / Non maintained EM / DALI dimming

*For more information about our control options,
just get in touch with our team.*

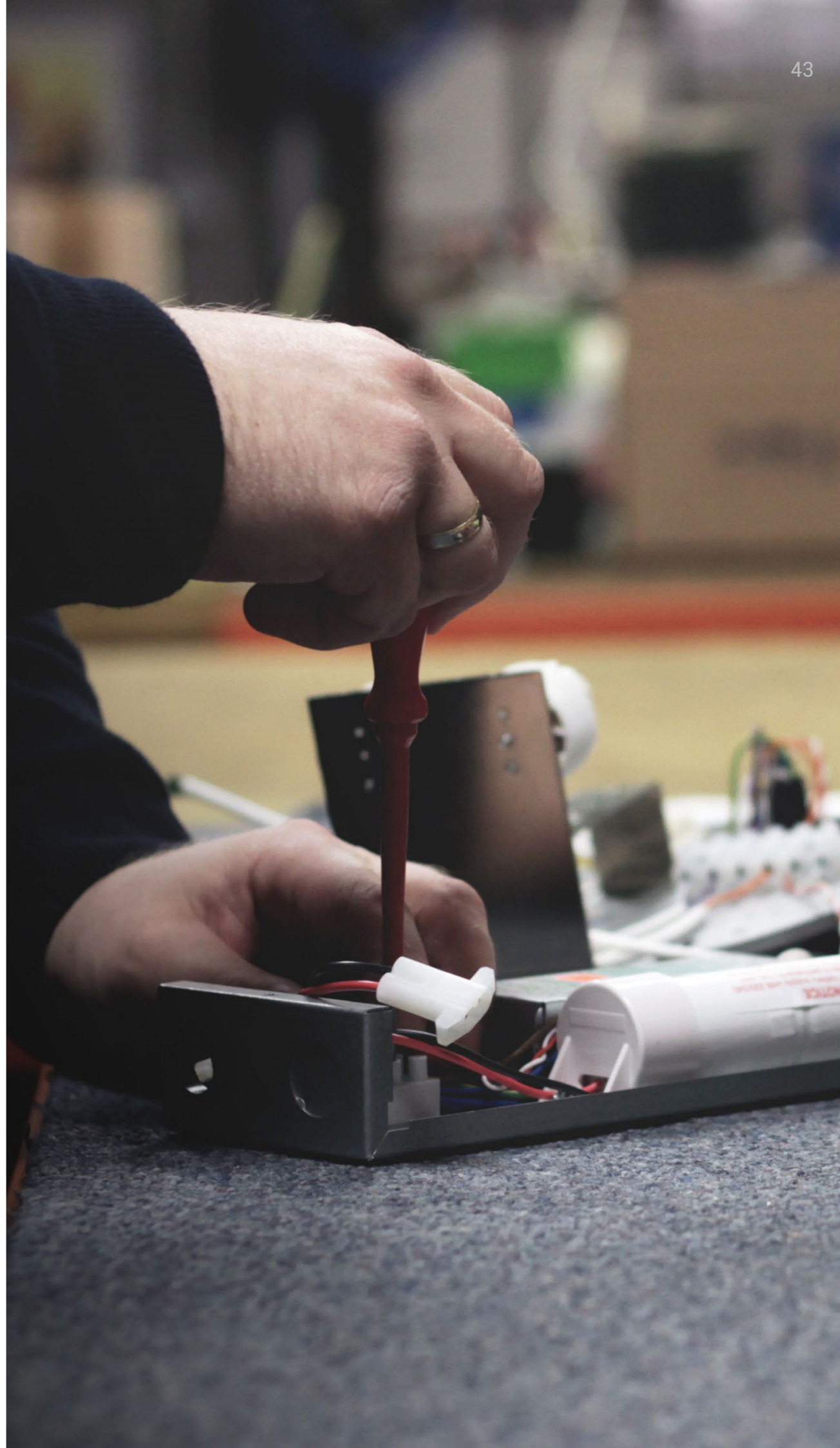

Bespoke Design

Product Modification

This catalogue lists only some of the options our Sovereign products offer. Commercial Lighting has extensive experience creating custom adaptations for our clients.

Need a specific housing colour, light source or bespoke colour rendering index? We can help.

Custom Product Design

Need a unique feature pendant, a specific housing design, or a solution no currently offered in our Sovereign range? Get in touch.

Many of our Sovereign products began as custom designs made in collaboration with clients.

Lighting Solutions

Our facilities include a dedicated in-house design team, metal workshop, in-house powder coating plant, and a team of experienced electrical assemblers.

This enables us to develop completely bespoke lighting solutions for any project.



the ReVive service

Our ReVive service puts sustainability at the heart.

Utilising 20+ years experience in sensitive restoration and refurbishment, Commercial Lighting gives old products new life, bringing them in line with the very latest standards, efficiency and performance.

The ReVive process:

- | | | |
|---|--------------|---|
| 1 | Assessment | We'll discuss all details of the current system with you to assess viability. We might ask for a sample or arrange collection via a site visit. |
| 2 | Proposal | Our technical team will create a full proposal, identifying the best solution for your project. This will comparison between current and proposed new fittings. |
| 3 | First-off | Our in house specialist production team will produce a sample for approval before full production. Depending on complexity, the conversions can be done in our manufacturing facilities, or custom upgrade kits can be sent for conversion on site. |
| 4 | Refurbish | We refurbish and upgrade all your products and apply rigorous testing procedures. |
| 5 | Installation | Your products are returned and re-installed using existing fixings for minimal disruption. Your fittings will be covered by our 5 year comprehensive warranty. |



££

Cheaper than
buying new



Less
carbon impact



Less
waste



Improved
efficiency



Better
illumination



Extended
lifetime

About us

Commercial Lighting Systems Ltd was established in Hampshire in 1991. The company is dedicated to offering the best quality, energy-efficient lighting to the UK market.

Our business is client-led, and made up of three divisions: reputable product ranges, bespoke design, and our flagship ReVive service for restoring and updating older lighting systems.

With almost 30 employees, many working here for over 20 years, our size lets us handle projects of any size. This allows us to maintain a personal approach to business, particularly advantageous for projects with unique specifications.

Our Values

How we do business is just as important as the end product. Our approach is built around quality, honesty, and sustainability.

We continually invest in technologies that help us minimise our environmental impact. From solar panels and full EV fleet to our minimal waste policy, we ensure every stage of our operations is considered for its impact on the environment.





SOVEREIGN®

The signature range from
Commercial Lighting Systems Ltd