



*Sovereign*







# Projectors



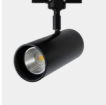
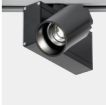
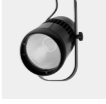
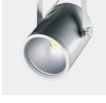
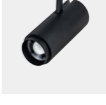

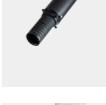
The signature range from  
Commercial Lighting Systems Ltd

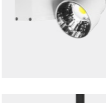
# Index

	<b>Round Minimal</b> <i>Projector</i>	8
	<b>Round Shallow</b> <i>Projector</i>	10
	<b>Round Vertical</b> <i>Projector</i>	12
	<b>SLM</b> <i>Projector</i>	22
	<b>Tubular</b> <i>Spotlight</i>	26
	<b>Zoom</b> <i>Projector</i>	32
	<b>Zoom+</b> <i>Projector</i>	34
	<b>Framing</b> <i>Projector</i>	38
	<b>Gobo</b> <i>Projector</i>	42
	<b>Art</b> <i>Spotlight</i>	46
	<b>48V</b> <i>Projector</i>	50
	<b>Soloflood</b> <i>Projector</i>	54

*the*  
**Round  
Projector**  
*ranges*

Our most versatile family of projectors, perfectly suited for most interior settings. Our Round Projectors have been successfully installed in many retail, museum and heritage applications over the years, becoming one of the most iconic Sovereign ranges.







Extensively customisable as standard, the Sovereign Round Projectors are also perfectly suited to our Bespoke Design service, allowing for fundamental modifications such as wall-washer illumination.





Product Family		Beam		Mounting		Bezel Colour		CCT & Output		Suffix
S18368	Round Minimal	SP	Spot	/TR	Track adapter	/05	White	00	3000K 9.8W	.8
		FL	Flood	/CP	Ceiling Plate	/04	Black	02	4000K 9.8W	
		WFL	Wide Flood			/21	Silver	03	3000K 14.1W	
								04	4000K 14.1W	

Dimmable and control options available. See page 56 for details.

# Round Minimal

Track / Ceiling

## LIGHT DETAILS

Wattage	CCT	Lumens	Efficacy
9.4W	3000K	1346lm	143lm/W
9.4W	4000K	1423lm	151lm/W
13.6W	3000K	1824lm	134lm/W
13.6W	4000K	1928lm	142lm/W

Our signature LED projector, the Sovereign Round Minimal Spotlight boasts a beautifully minimal design thanks to the driver being incorporated within the main lamp housing.

Designed around the latest Tridonic SLE LED modules with optical lenses to suit a range of applications. Can also accept any of our standard Electronic Spotlight accessories including colour filter lenses, honeycomb louvres, barn doors etc.

Available with dimming gear as an option with track adaptor or ceiling plate mounting. Standard colours black, white, and silver as standard with other BS/RAL colours to order.

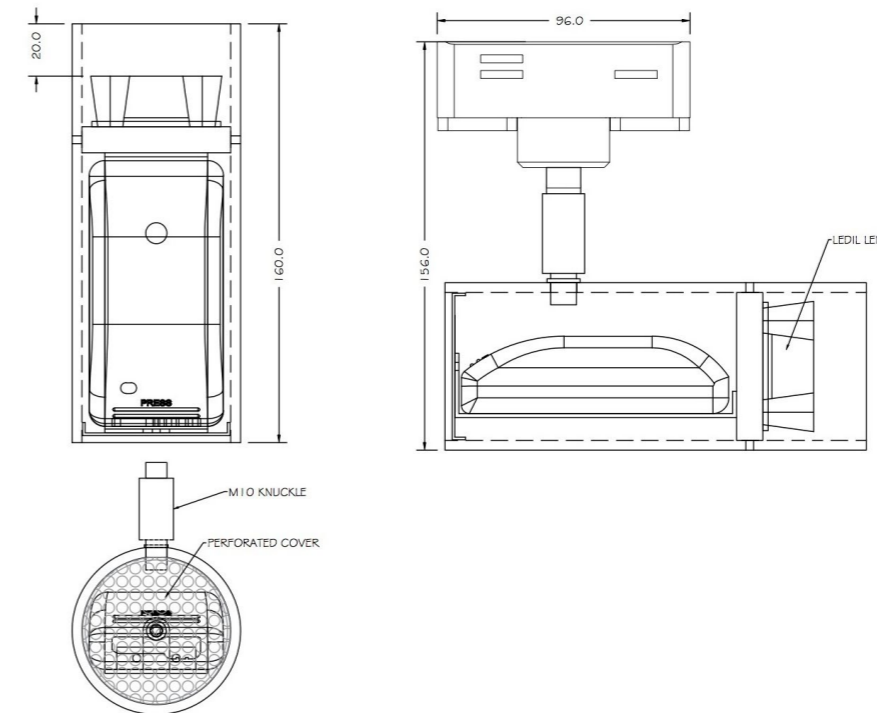

## PHOTOMETRY

Wide flood

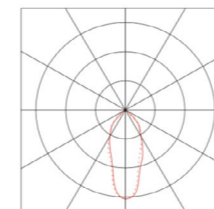

Flood

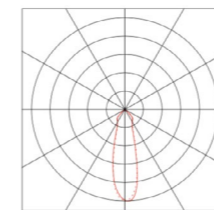

Spot

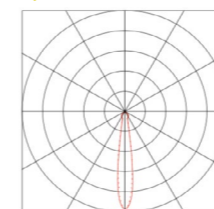

## TECHNICAL SPECIFICATIONS

IP rating	IP20
CRI	>80
Lamp Life	50,000 hours
Light Source	Tridonic SLE LED
Voltage	240V
Driver	Integrated high efficiency
LED Warranty	5 Years

## HOUSING

Material	Extruded aluminium
Finish	Powder coated
Protection Rating	Class 1
Optics	Reflector
Weight	0.66kg
Mounting	Track / Surface mounting
Accessories	( see page 16)

## Round Minimal



Projectors



Product Family	Beam	Mounting	Bezel Colour	CCT & Output	Suffix
<b>S18310</b> Round Shallow	<b>SP</b> Spot	<b>/TR</b> Track adapter	<b>/05</b> White	<b>00</b> 3000K 9.4W	<b>.8</b>
	<b>FL</b> Flood	<b>/CP</b> Ceiling Plate	<b>/04</b> Black	<b>02</b> 4000K 9.4W	
	<b>WFL</b> Wide Flood		<b>/21</b> Silver	<b>03</b> 3000K 13.6W	
				<b>04</b> 4000K 13.6W	
				<b>06</b> 3000K 15.8W	
				<b>07</b> 4000K 15.8W	

Dimmable and control options available. See page 56 for details.

# Round Shallow

Track / Ceiling

## LIGHT DETAILS

Wattage	CCT	Lumens	Efficacy
9.4W	3000K	1346lm	143lm/W
9.4W	4000K	1423lm	151lm/W
13.6W	3000K	1824lm	134lm/W
13.6W	4000K	1928lm	142lm/W
15.8W	3000K	2059lm	131lm/W
15.8W	4000K	2176lm	138lm/W

Updated to the very latest Tridonic LES10 LED modules, this highly successful spotlight now offers even greater efficiency with enhanced performance and particularly low energy consumption.

This Round Shallow Spotlight uses high quality extruded aluminium profile with machined heatsink for optimum heat dissipation and longevity. Integral high performance LED driver is fitted as standard.

Available with 3-circuit track adaptor or ceiling plate. Also available with optional built in dimming control making it an ideal choice for museums, galleries etc.

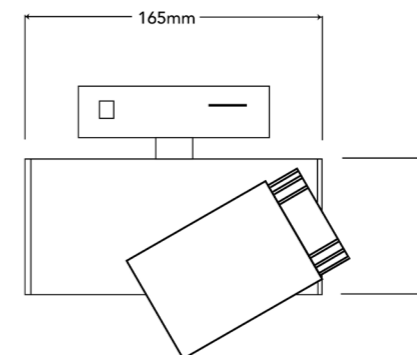
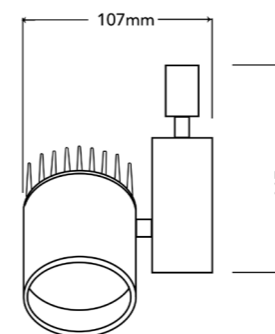

## PHOTOMETRY

Wide flood

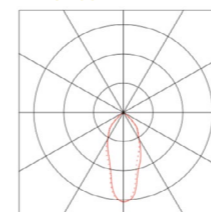

Flood

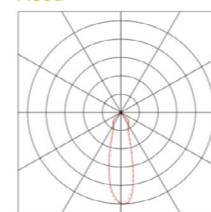

Spot

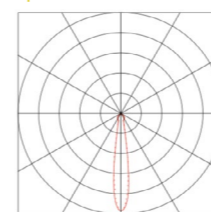

## TECHNICAL SPECIFICATIONS

IP rating	IP20
CRI	>80
Lamp Life	50,000 hours
Light Source	Tridonic SLE LED
Voltage	240V
Driver	250mA / 350mA
LED Warranty	5 Years

## HOUSING

Material	Extruded aluminium
Finish	Powder coated
Protection Rating	Class 1
Optics	Reflector
Weight	1.3kg
Mounting	Track / surface mounted
Accessories	( see page 16 )

## Round Shallow



Projectors





Product Family	Beam	Mounting	Bezel Colour	CCT & Output	Suffix
S18311 Round vertical	SP Spot	/TR Track adapter	/05 White	00 3000K 9.4W	.8
	FL Flood	/CP Ceiling Plate	/04 Black	02 4000K 9.4W	
	WFL Wide Flood		/21 Silver	03 3000K 13.6W	
				04 4000K 13.6W	
				06 3000K 15.8W	
				07 4000K 15.8W	

Dimmable and control options available. See page 56 for details.

# Round Vertical

Track / Ceiling

## LIGHT DETAILS

Wattage	CCT	Lumens	Efficacy
9.4W	3000K	1346lm	143lm/W
9.4W	4000K	1423lm	151lm/W
13.6W	3000K	1824lm	134lm/W
13.6W	4000K	1928lm	142lm/W
15.8W	3000K	2059lm	131lm/W
15.8W	4000K	2176lm	138lm/W

Updated to the very latest Tridonic LES10 LED modules, this highly successful spotlight now offers even greater efficiency with enhanced performance and particularly low energy consumption.

Manufactured in our own Hampshire factory to exacting standards, this Round Shallow Spotlight range uses high quality extruded aluminium profile with machined heatsink for optimum heat dissipation and longevity. Integral high performance LED driver is fitted as standard.

Available with 3-circuit track adaptor or ceiling plate. Also available with optional built in dimming control making it an ideal choice for museums, galleries etc.

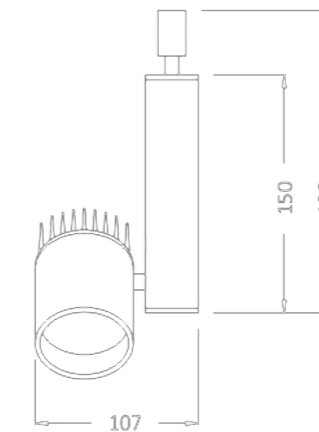
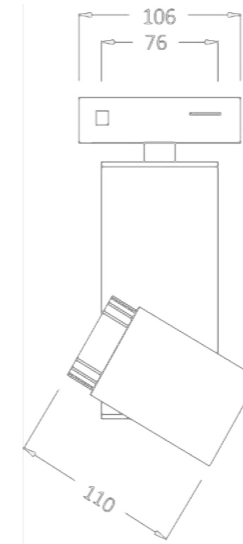

## PHOTOMETRY

Wide flood

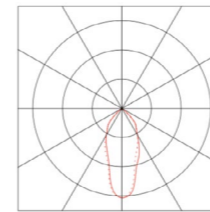

Flood

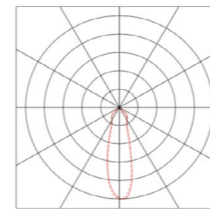

Spot

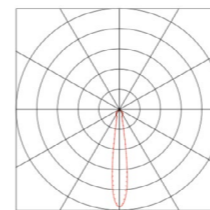

## TECHNICAL SPECIFICATIONS

IP rating	IP20
CRI	>80
Lamp Life	50,000 hours
Light Source	Tridonic SLE LED
Voltage	240V
Driver	250mA / 350mA
LED Warranty	5 Years

## HOUSING

Material	Extruded aluminium
Finish	Powder coated
Protection Rating	Class 1
Optics	Reflector
Weight	1.3kg
Mounting	Track / Surface mounted
Accessories	( see page 16 )

## Round Vertical



Projectors



## Accessories

A full range of accessories is available for use with our highly successful British designed and built Round projectors. All versions are based around a high quality machined mounting frame incorporating a ball catch system for ease of use. Can be easily retrofitted to fittings already supplied.

Order Code	Description
950.0323	Honeycomb Louvre
950.0325.020	Blue Filter
950.0325.030	Amber Filter
950.0325.040	Green Filter
950.0325.060	Red Filter
950.0325.070	Yellow Filter
950.0336	Barn Door
950.0342	Spreader Lens
950.0343	Frosted Lens

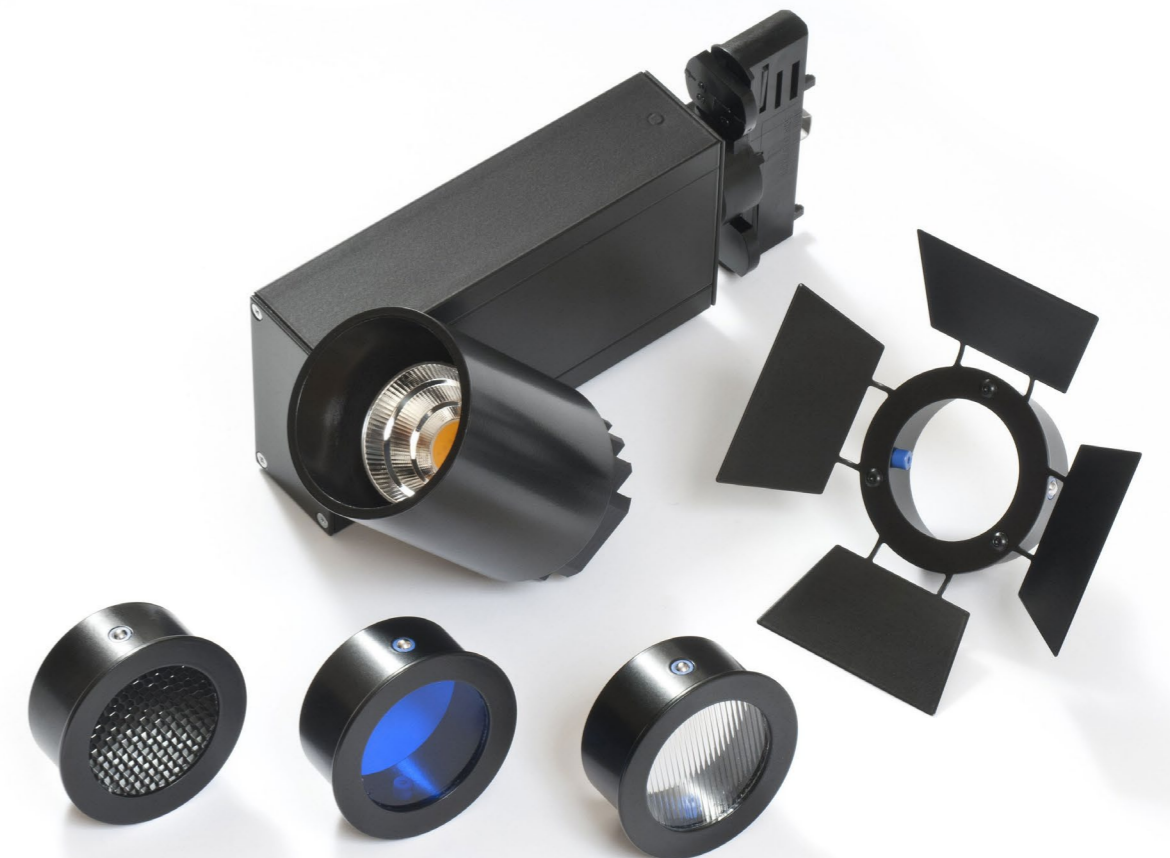





**DISCOVERING HAMWIC**

Recent excavations have found a 10th-century site in the village of Hamwic, which is now part of the city of Winchester. The site was a major trading center and is thought to be the location of the famous Saxon town of Hamwic. The excavations have revealed a large area of buildings, including a church and a palace. The site is now a National Monument and is open to the public.



**They've struck bid under aints stadium**



**Digging the Saxons who**

**CRAFT AND MANUFACTURE**

This section of the exhibit focuses on the craft and manufacture of various items, including pottery, metalwork, and textiles. It features a display case with several artifacts and a large informational panel with text and images.





*the*  
**SLM**  
**Projector**  
*range*



One of our most popular projectors, the Sovereign SLM provides quality, high output illumination, as well as RGBW options.





The SLM is highly versatile, suitable for a wide range of applications such as museums, heritage and faith buildings.





Product Family	Beam Angle	Mounting	Housing Colour	Version	Suffix
S18322 SLM	SP Spot	/TR Track adapter	/05 White	02 3000K 18.42W	.8
	FL Flood	/CP Ceiling plate	/04 Black	03 4000K 18.42W	
	WFL Wide flood		/21 Silver	04 3000K 26.44W	
				05 4000K 26.44W	
				54 3000K 34.34W	
				60 4000K 34.34W	
				67 3000K 38.97W	
				68 4000K 38.97W	
				24L RGBW 16.8W	
				24H RGBW 28.8W	

Dimmable and control options available. See page 56 for details.

# SLM projector

Track / Ceiling Mounted

## LIGHT DETAILS

Wattage	CCT	Lumens	Efficacy
18.42W	3000K	2740lm	149lm/W
18.42W	4000K	2836lm	154lm/W
26.44W	3000K	3726lm	141lm/W
26.44W	4000K	3833lm	145lm/W
34.34W	3000K	4941lm	144lm/W
34.34W	4000K	5152lm	150lm/W
38.97W	3000K	5916lm	152lm/W
38.97W	4000K	6169lm	159lm/W
RGBW	16.8W	804lm	48lm/W
RGBW	28.8W	1207lm	42lm/W

A high quality aesthetically pleasing LED projector designed specifically for use with the very latest generation Tridonic SLE LED modules.

Housing manufactured from spun aluminium with integrated passive heatsink technology for optimum thermal management, leading to exceptional performance in excess of 140 lm/W for 3000K and 4000K versions. Also available with RGBW.

High purity aluminium reflector system in a choice of beam angles. Integral high efficiency LED driver with dimmable versions available on request. Manufactured in our own Hampshire factory to exacting standards to ensure longevity.

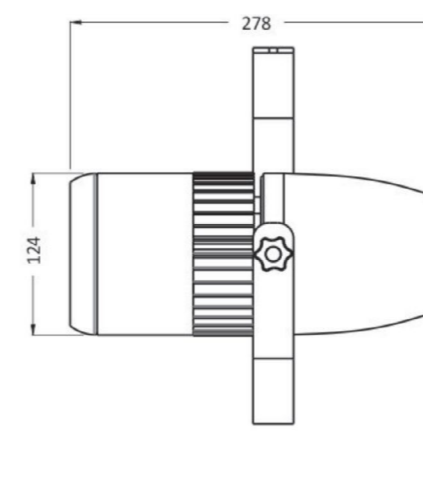
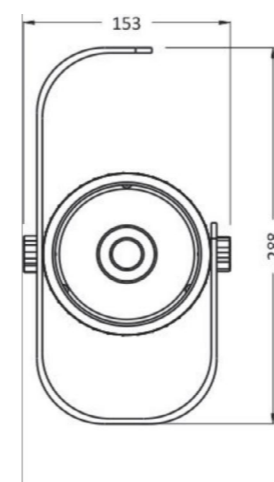

## PHOTOMETRY

### Wide flood

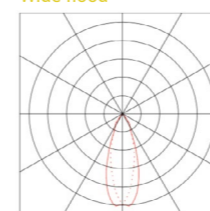

### Flood

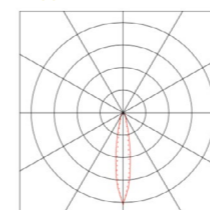

### Spot

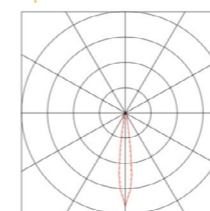

## TECHNICAL SPECIFICATIONS

IP rating	IP40
CRI	>80
Lamp Life	50,000 hours
Light Source	Tridonic SLE
Beam	15° / 26° / 45°
Voltage	240V
Driver	High efficiency

## HOUSING

Material	Aluminium
Finish	Powder coated
Protection Rating	Class 1
Optics	Clear Glass
Weight	2.8kg
Mounting	Track adapter / ceiling plate
Accessories	( see page 26)

## SLM Projector

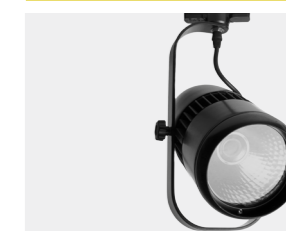



A full range of accessories is available for use with our highly successful British designed and built SLM projectors. All versions are easily mounted onto the SLM housing. Can be easily retrofitted to fittings already supplied.

Order Code	Description
950.3336	Honeycomb Louvre
950.0335.020	Blue Filter
950.0335.030	Amber Filter
950.0335.040	Green Filter
950.0335.060	Red Filter
950.0325.070	Yellow Filter
950.0337	Barn Door

## Accessories

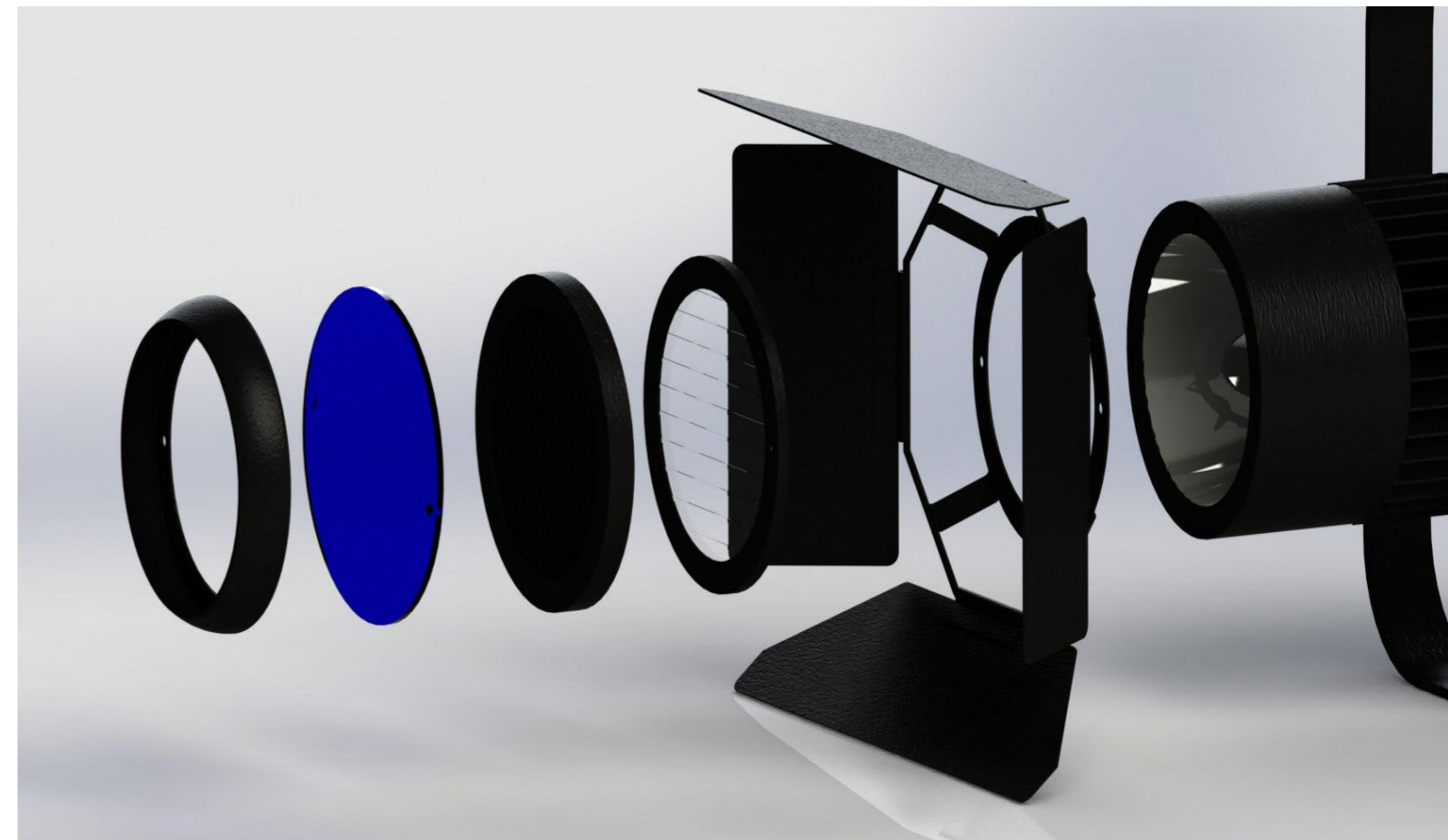



*the*  
**Tubular  
Spotlight**  
*range*



The Tubular Spotlight has been a popular mainstay of the Sovereign range, now fully updated to incorporate the latest LED technology.



Product Family	Mounting	Housing Colour	CCT & Output	Suffix
S18344 Tubular Spot	TR Track adapter	/05 White	00 3000K 18.4W	.8
	CP Ceiling plate	/04 Black	01 4000K 18.4W	
		/21 Silver	06 3000K 34W	
			08 4000K 34W	
			10 3000K 26W	
			11 4000K 26W	

Dimmable and control options available. See page 56 for details.

# Tubular

Track / Ceiling Spotlight

## LIGHT DETAILS

Wattage	CCT	Lumens	Efficacy
18.4W	3000K	2815lm	153lm/W
18.4W	4000K	2936lm	160lm/W
26W	3000K	3838lm	147lm/W
26W	4000K	4002lm	154lm/W
34W	3000K	4823lm	132lm/W
34W	4000K	5029lm	148lm/W

The Tubular Spotlight provides an alternative to the SLM projector. Providing similarly high output illumination, the Tubular Spotlight offers a more compact style.

Keeping its iconic minimalist design, the high quality spun aluminium luminaire is assembled in our Hampshire factory using carefully selected components for maximum longevity.

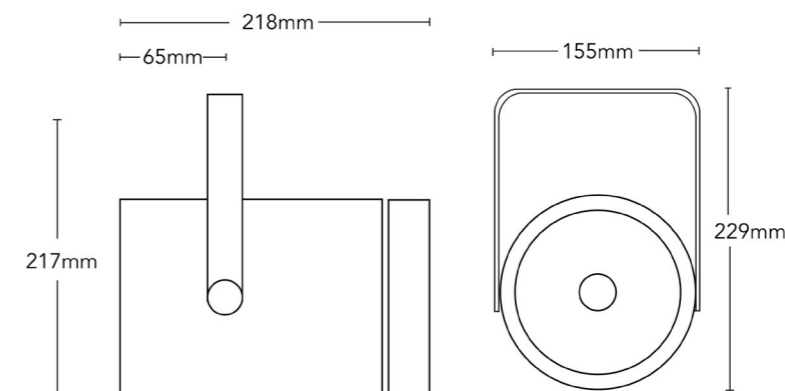

## PHOTOMETRY

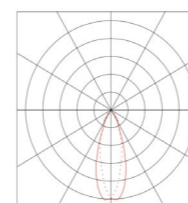

## TECHNICAL SPECIFICATIONS

IP rating	IP40
CRI	>80
Lamp Life	50,000 hours
Light Source	Tridonic SLE LED
Voltage	240V
Driver	Integrated high efficiency
LED Warranty	5 Years

## HOUSING

Material	Aluminium
Finish	Powder coated
Protection Rating	Class 1
Optics	Clear glass
Weight	2.8kg
Mounting	Track adapter / ceiling plate

## Tubular Spotlight

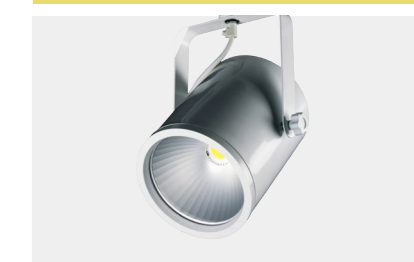

Projectors



the  
**Zoom**  
**Projector**  
*ranges*



Adjustable telescopic lens for precise beam configuration makes these projectors ideal for museum and exhibition lighting.





Product Family	Mounting	Housing Colour	CCT	Suffix
S18400 Zoom 20W	TR Track adapter	/05 White	00 2700K	.8
S18401 Zoom 30W		/04 Black	01 3000K	
S18402 Zoom 35W		/21 Silver	02 4000K	

Dimmable and control options available. See page 56 for details.

# Zoom

Track Projector

## LIGHT DETAILS

Wattage	CCT	Lumens	Efficacy
20W	2700K	1965lm	98lm/W
20W	3000K	1984lm	99lm/W
20W	4000K	2049lm	102lm/W
30W	2700K	3065lm	102lm/W
30W	3000K	3082lm	103lm/W
30W	4000K	3150lm	105lm/W
35W	2700K	3482lm	99lm/W
35W	3000K	3502lm	100lm/W
35W	4000K	3570lm	102lm/W

The Sovereign Zoom Projector has an adjustable telescopic lens for precise beam configuration. Together with the high colour rendering of CRI 90, this projector is ideal for applications such as museum and exhibition lighting.

Available in 3 sizes, outputs and colour temperatures, the Sovereign Zoom comes in white, black or silver.

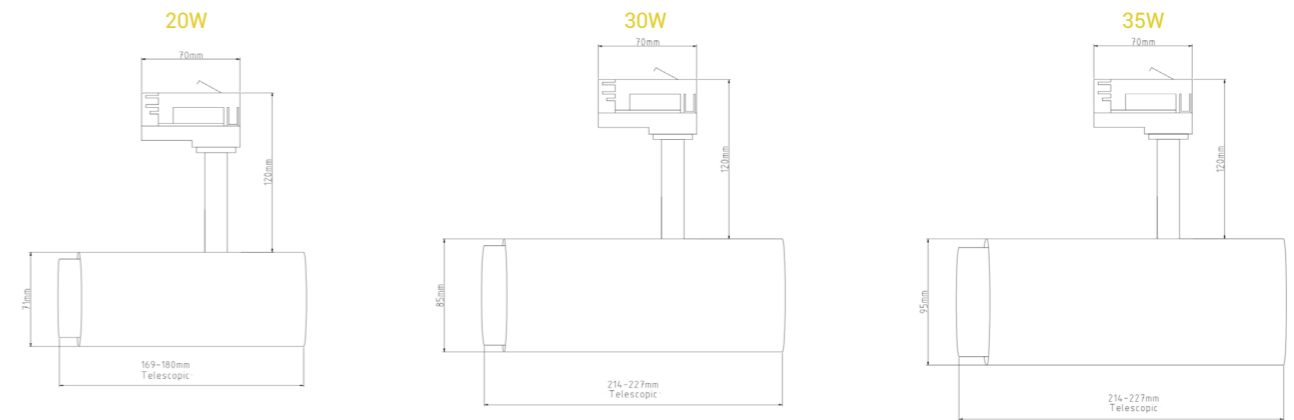

## PHOTOMETRY

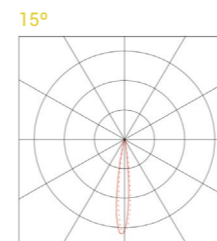
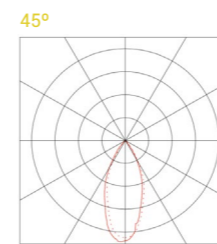

## TECHNICAL SPECIFICATIONS

IP rating	IP20
CRI	>80
Lamp Life	50,000 hours
Light Source	CREE / Philips / Osram COB
Voltage	240V
Driver	Integrated high efficiency
Beam	15°-60° (15°-45° for 20W)
LED Warranty	5 Years

## HOUSING

Material	Aluminium
Finish	Powder coated
Protection Rating	Class 1
Optics	Adjustable
Weight	0.8kg
Mounting	Track adapter / ceiling plate

## Zoom Projector



Projectors



Product Family		Housing Colour		CCT & Output		Suffix
S18400	Zoom+	/05	White	00	2700K 20W	.8
		/04	Black	01	3000K 20W	
		/21	Silver	02	4000K 20W	
				00	2700K 30W	
				01	3000K 30W	
				02	4000K 30W	

Dimmable and control options available. See page 56 for details.

# Zoom+

Track Projector

## LIGHT DETAILS

Wattage	CCT	Lumens	Efficacy
20W	2700K	2000lm	100lm/W
20W	3000K	2200lm	110lm/W
20W	4000K	2200lm	110lm/W
30W	2700K	3065lm	102lm/W
30W	3000K	3082lm	103lm/W
30W	4000K	3150lm	105lm/W

An exciting new addition to the Sovereign Zoom Projector range, the Zoom+ offers an adjustable telescopic lens with beam angle from an exceptionally narrow 6° through to a wide 60° all with a simple twist of the front housing, making this unit perfect for museums or any application involving changing displays.

Using the latest LED technology, this version is supplied as standard with high colour rendering CRI 90 and is available in a choice of colour temperatures. Available in durable white, black or silver powder coated finish.

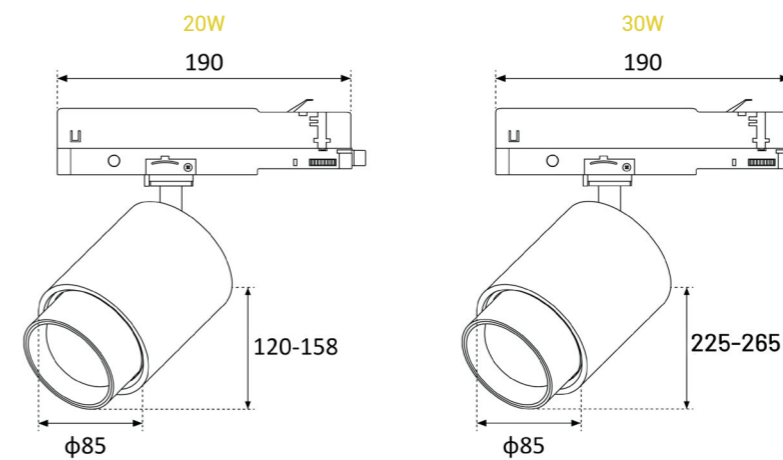

## TECHNICAL SPECIFICATIONS

IP rating	IP20
CRI	>90
Lamp Life	50,000 hours
Light Source	Philips COB LED
Voltage	240V
Beam	6° - 60°
Driver	Integrated in adapter

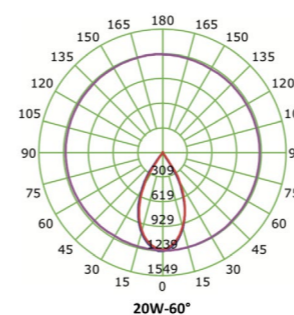
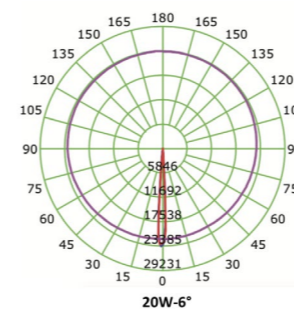

## HOUSING

Material	Aluminium
Finish	Powder coated
Protection Rating	Class 1
Optics	Adjustable
Weight	1.55kg
Mounting	Track Mounted

## Zoom+ Projector



Projectors





*the*  
**Framing  
Projector**  
*range*



Designed for the Gallery and Museum sectors, this projector allows for precise, shaped projection to carefully accentuate individual objects and artworks.



Product Family		Mounting		Housing Colour		CCT & Output		Suffix
S18388	Framing Projector	TR	Track adapter	.05	White	00	3000K 15W	.8
		CP	Ceiling plate	.04	Black	01	4000K 15W	
				.21	Silver	02	3000K 30W	
						03	4000K 30W	

Dimmable and control options available. See page 56 for details.

# Framing Projector

Track / Ceiling

## LIGHT DETAILS

Wattage	CCT	Lumens	Efficacy
15W	3000K	1932lm	90lm/W
15W	4000K	1987lm	90lm/W
30W	3000K	2740lm	100lm/W
30W	4000K	2836lm	100lm/W

This projector provides an adjustable square and rectangular light output for precision illumination.

Different shapes are made through shuttering down, while the adjustable lens allows controls the size.

Available in multiple outputs and colour temperatures.

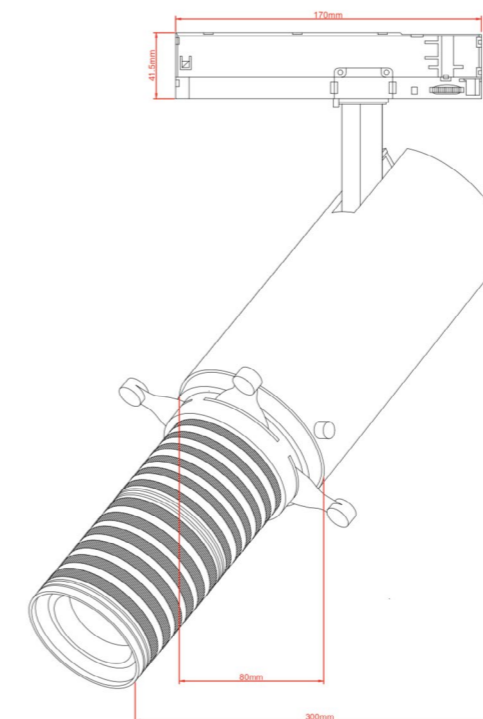

## TECHNICAL SPECIFICATIONS

IP rating	IP20
CRI	>90
Lamp Life	50,000 hours
Light Source	COB LEDs
Voltage	240V
Driver	Integrated high efficiency
LED Warranty	5 Years

## HOUSING

Material	Aluminium
Finish	Powder coated
Protection Rating	Class 1
Optics	Adjustable
Weight	2.58kg
Mounting	Track adapter / Ceiling plate

## Framing Projector



Projectors



the  
**Gobo**  
Projector  
range



A specialised luminaire for the Gallery and Museum sectors, offering the highest light quality with its impressive full spectrum technology and high CRI of 98.



Product Family		Mounting		Housing Colour		CCT & Output		Suffix
S18389	Gobo Projector	SP	Spot	.05	White	00	3000K 30W	.8
		FL	Flood	.04	Black	01	3700K 30W	
		WFL	Wide flood	.21	Silver	02	4000K 30W	
						03	5000K 30W	
						04	3000K 60W	
						05	3700K 60W	
						06	4000K 60W	
						07	5000K 60W	

Dimmable and control options available.  
See page 56 for details.

# Gobo Projector

Track / Ceiling

An elegant and powerful surface or track mounted projector, with adjustable framing fingers for focusing and high quality lens to ensure optimum light quality.

Available in a range of outputs, beam angles and colour temperatures. Main housing come in white as standard, but also available in any BS/RAL colours. Gobo to be ordered separately (Size E).

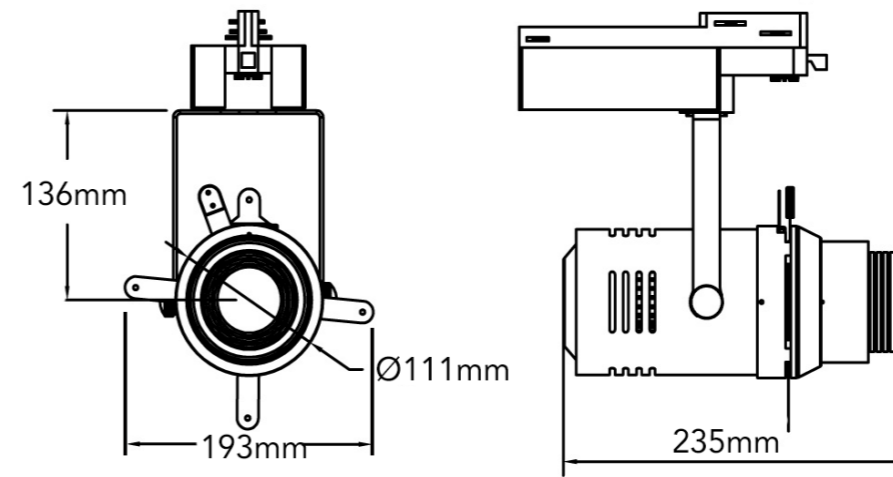

## TECHNICAL SPECIFICATIONS

IP rating	IP20
CRI	>80
Lamp Life	50,000 hours
Light Source	LED
Colour Temp	3000K / 3700K / 4000K / 5000K
Lumen Output	3000 ~ 4000K
Beam	15° / 25° / 35°
Voltage	240V
Driver	Integrated high efficiency
LED Warranty	5 Years

## HOUSING

Material	Aluminium
Finish	Powder coated
Protection Rating	Class 1
Optics	Adjustable glass lens
Weight	2.5kg
Mounting	Track / surface mounted

## Gobo Projector



Projectors



the  
**Art  
Spotlight**  
range

A specialised luminaire for the Gallery and Museum sectors, offering the highest light quality with its impressive full spectrum technology and high CRI of 98.

*Art Spotlight*

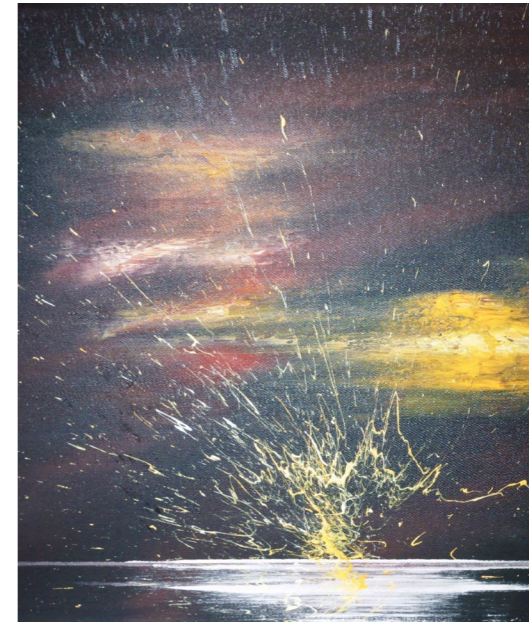

*Standard Spotlight*

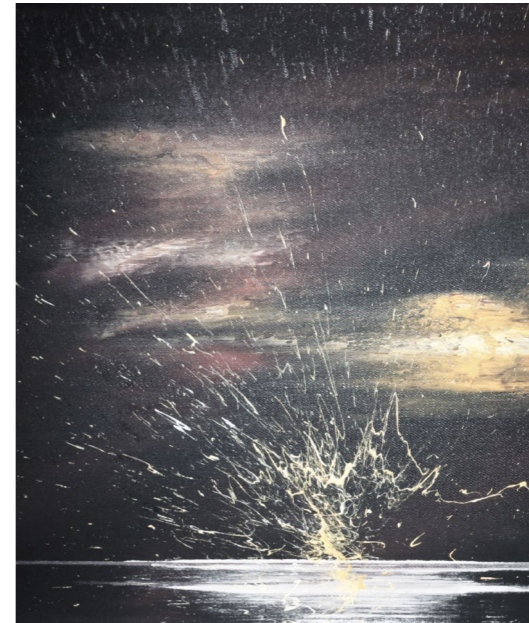



Product Family	Beam	Mounting	Housing Colour	CCT & Version	Suffix
S18369 Art Spotlight	SP Spot	/TR Track adapter	/05 White	00 3000K Shallow	.8
	FL Flood	/CP Ceiling Plate	/04 Black	01 4000K Shallow	
	WFL Wide Flood		/21 Silver	02 3000K Vertical	
				03 4000K Vertical	

Dimmable and control options available. See page 56 for details.

# Art Spotlight

Track / Ceiling

## LIGHT DETAILS

Wattage	CCT	Lumens	Efficacy
16.8W	3000K	2000lm	119lm/W
16.8W	4000K	2000lm	119lm/W

The Sovereign ART LED Spotlight offers the highest light quality with its impressive full spectrum technology and high CRI of 98. Far outperforming standard spotlights in its colour rendering ability, the ART LED Spotlight is an ideal choice for artwork and exhibit illumination, as well as for use in the retail sector.

Manufactured in our own Hampshire factory to exacting standards, the Sovereign ART LED Spotlight uses high quality extruded aluminium profile with machined heatsink for optimum heat dissipation and longevity. Integral high performance LED driver is fitted as standard.

Available in both vertical and shallow versions, and with 3-circuit track adaptor or ceiling plate. Also available with optional built in dimming control.

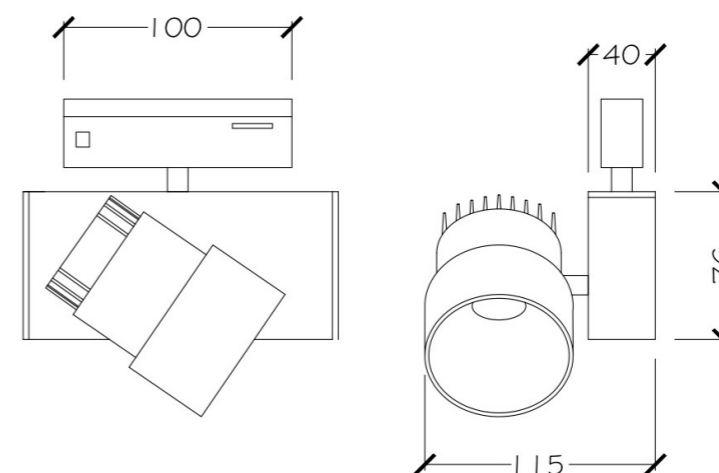

## PHOTOMETRY

Wide flood

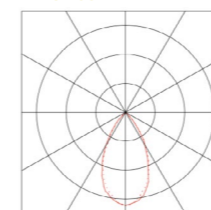

Flood

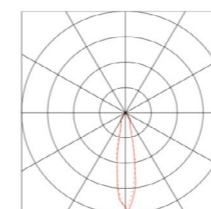

## TECHNICAL SPECIFICATIONS

IP rating	IP20
CRI	98
Lamp Life	50,000 hours
Light Source	Tridonic SLE ART EXC
Beam	15° / 25° / 40°
Voltage	240V
Driver	High efficiency
LED Warranty	5 Years

## HOUSING

Material	Aluminium
Finish	Powder coated
Protection Rating	Class 1
Optics	Reflector
Weight	0.6kg
Mounting	Track / surface mounted

## Art Spotlight



Projectors



the  
**48V**  
**Projector**  
range

Our smallest projector range, offering high quality illumination from the most compact of luminaires.

The adjustable lens allows for 15°-45° beam angles, with an impressive colour rendering of 90Ra.





Product Family		Mounting		Housing Colour		CCT & Output		Suffix
S18375	6W 48V	.TR48	48V Track	.05	White	00	2700K	.8
S18376	10W 48V			.04	Black	01	3000K	
						02	4000K	

Dimmable and control options available.  
See page 56 for details.

# 48V Projector

Adjustable Track Mounted

## LIGHT DETAILS

Wattage	CCT	Lumens	Efficacy
6W	2700K	660lm	110lm/W
6W	3000K	660lm	110lm/W
6W	4000K	660lm	110lm/W
10W	2700K	1100lm	110lm/W
10W	3000K	1100lm	110lm/W
10W	4000K	1100lm	110lm/W

The Sovereign 48V Track Projector is our smallest projector range, offering high quality illumination from the most compact of luminaires.

The adjustable lens allows for 15°-45° beam angles, with an impressive colour rendering of 90Ra, mounted on 48V track available in a range of lengths.

Available in two sizes, along with a range of colour temperatures and housing colours.

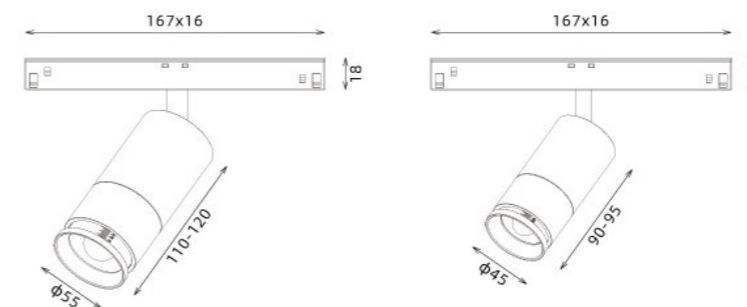

## PHOTOMETRY

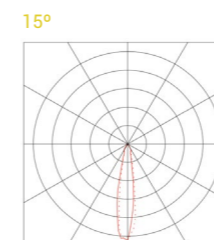
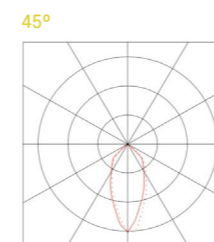

## TECHNICAL SPECIFICATIONS

IP rating	IP40
CRI	>90
Lamp Life	50,000 hours
Light Source	CREE COB LEDs
Beam	15°-45°
Voltage	240V
Driver	High efficiency
LED Warranty	5 Years

## HOUSING

Material	Aluminium
Finish	Powder coated
Protection Rating	Class 1
Optics	Adjustable
Weight	0.6kg
Mounting	48V Track mounted
Dimensions	Ø45xH90 @6W Ø55xH110 @10W

## 48V Projector





the  
**Soloflood**  
Projector  
range

A powerful and flexible projector, used successfully in a range of applications, from churches to retail.







Product Family	Mounting	Housing Colour	CCT	Suffix
S18394 Soloflood	Stirrup only	.05 Textured white	00 3000K	.8
	TR Track adapter	.04 Textured black	01 4000K	
	CP Ceiling plate	.21 Textured silver		

Dimmable and control options available. See page 56 for details.

# Soloflood

Track / Ceiling Projector

## LIGHT DETAILS

Wattage	CCT	Lumens	Efficacy
25.5W	3000K	4060lm	159lm/W
25.41W	4000K	4240lm	167lm/W

Our Soloflood LED projector is the perfect solution for any interior project requiring a high level of illumination over larger areas including churches, large retail outlets etc.

Manufactured in the UK using our own aluminium extruded housing with aluminium end plates and designed around the very latest generation of Tridonic LED components for optimum performance and longevity.

Supplied as standard with high efficiency non dimming driver but also available with a range of dimming options and power output. Standard colours black, white, and silver as standard with other BS/RAL colours to order.

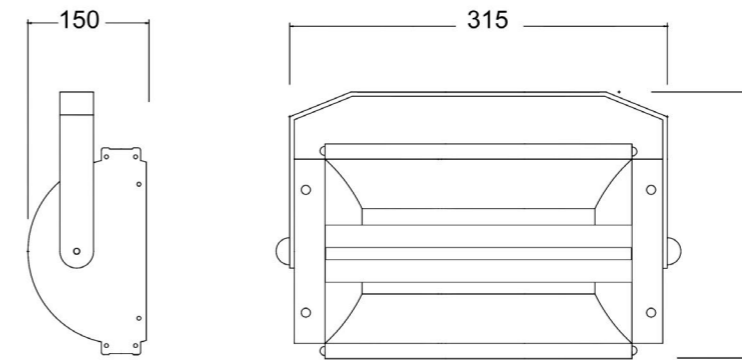

## TECHNICAL SPECIFICATIONS

IP rating	IP20
CRI	>90
Lamp Life	50,000 hours
Light Source	Tridonic LLE LED
Voltage	240V
Driver	Integrated high efficiency
LED Warranty	5 Years

## HOUSING

Material	Die-cast Aluminium
Finish	Powder coated
Protection Rating	Class 1
Optics	Opal tubes diffuser
Weight	2.8.kg
Mounting	Surface /Track mounting

## Soloflood Projector



Projectors



# Dimming & Lighting Control

All of our Sovereign Projectors are available with a full range of dimming and control options.

To specify our projectors with our most popular lighting controls, insert the relevant code between the main product code and the suffix.

Product code	Control	Suffix
	1 1-10V dimming	.8
	2 DALI dimming	
	5 Switch dim	
	6 DMX	
	7 Bluetooth	

**Example: S1403/TR.0500.8**

Zoom+ Projector / Track Mounting / White housing / 2700K 20W / On/off control

**S1403/TR.0500/107.8**

Zoom+ Projector / Track Mounting / White housing / 2700K 20W / Bluetooth control

*For more information about our control options,  
just get in touch with our team.*





# Bespoke Design

## Product Modification

This catalogue lists only some of the options our Sovereign products offer. Commercial Lighting has extensive experience creating custom adaptations for our clients.

Need a specific housing colour, light source or bespoke colour rendering index? We can help.

## Custom Product Design

Need a unique feature pendant, a specific housing design, or a solution no currently offered in our Sovereign range? Get in touch.

Many of our Sovereign products began as custom designs made in collaboration with clients.

## Lighting Solutions

Our facilities include a dedicated in-house design team, metal workshop, in-house powder coating plant, and a team of experienced electrical assemblers.

This enables us to develop completely bespoke lighting solutions for any project.





# the ReVive service

Our ReVive service puts sustainability at the heart.

Utilising 20+ years experience in sensitive restoration and refurbishment, Commercial Lighting gives old products new life, bringing them in line with the very latest standards, efficiency and performance.

## The ReVive process:

- 1 **Assessment** We'll discuss all details of the current system with you to assess viability. We might ask for a sample or arrange collection via a site visit.
- 2 **Proposal** Our technical team will create a full proposal, identifying the best solution for your project. This will comparison between current and proposed new fittings.
- 3 **First-off** Our in house specialist production team will produce a sample for approval before full production. Depending on complexity, the conversions can be done in our manufacturing facilities, or custom upgrade kits can be sent for conversion on site.
- 4 **Refurbish** We refurbish and upgrade all your products and apply rigorous testing procedures.
- 5 **Installation** Your products are returned and re-installed using existing fixings for minimal disruption. Your fittings will be covered by our 5 year comprehensive warranty.



££

Cheaper than  
buying new



Less  
carbon impact



Less  
waste



Improved  
efficiency



Better  
illumination



Extended  
lifetime

## About us

Commercial Lighting Systems Ltd was established in Hampshire in 1991. The company is dedicated to offering the best quality, energy-efficient lighting to the UK market.

Our business is client-led, and made up of three divisions: reputable product ranges, bespoke design, and our flagship ReVive service for restoring and updating older lighting systems.

With almost 30 employees, many working here for over 20 years, our size lets us handle projects of any size. This allows us to maintain a personal approach to business, particularly advantageous for projects with unique specifications.

## Our Values

How we do business is just as important as the end product. Our approach is built around quality, honesty, and sustainability.

We continually invest in technologies that help us minimise our environmental impact. From solar panels and full EV fleet to our minimal waste policy, we ensure every stage of our operations is considered for its impact on the environment.







SOVEREIGN®

The signature range from  
Commercial Lighting Systems Ltd