

Sovereign













Wall Lights



Index

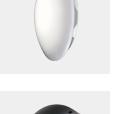

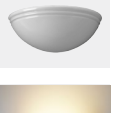
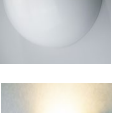
The signature range from
Commercial Lighting Systems Ltd

	Linear Mono <i>Wall Light</i>	6
	Linear Duo <i>Wall Light</i>	8
	Slim Uplight <i>Wall Light</i>	10
	Cube Up/down <i>Wall Light</i>	16
	Ecoblade Uplight <i>Wall Light</i>	20
	Ecoblade Up/down <i>Wall Light</i>	22
	Ecoblade Wedge <i>Wall Light</i>	24
	Slimline Square <i>Wall Light</i>	28
	Round <i>Wall Light</i>	32
	Pizza <i>Wall Light</i>	34
	Exterior Bulkhead <i>Wall Light</i>	38
	Saturn Up/down <i>Wall Light</i>	42
	Mini QS Uplight <i>Wall Light</i>	44
	Mini QS Up/down <i>Wall Light</i>	46
	Quarter Sphere <i>Wall Light</i>	48

the
Linear
wall light ranges

Beautiful, elegant wall lights providing high quality illumination. Available as an uplight or downlight, or as an up/downlight.

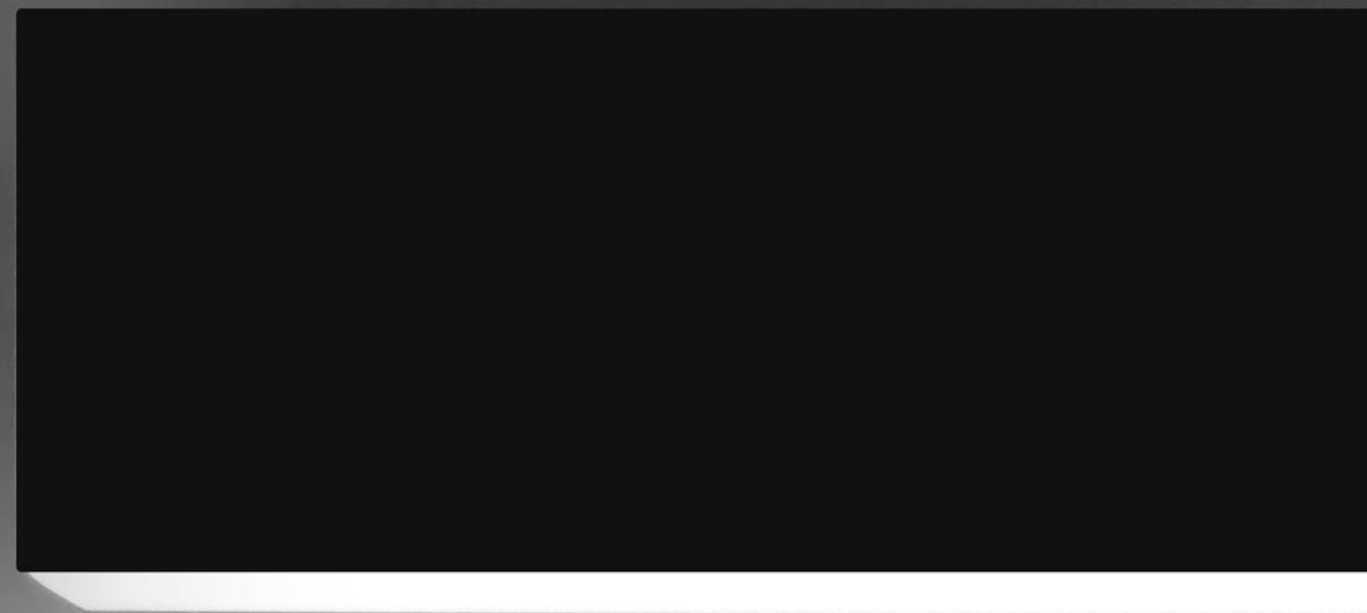



Product Family	Housing Colour	CCT	Suffix
S18510 150mm	/X5 Textured white	00 3000K	.8
S18511 300mm	/X4 Textured black	01 4000K	
S18512 450mm	/X2 Textured silver		
S18513 600mm			

EM and dimmable options available - see page 50 for ordering info.

Linear Mono

Wall Light

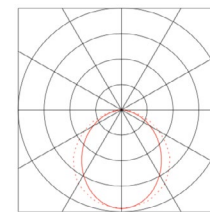

Size	Wattage	CCT	Lumens	Efficacy
150mm	4.3W	3000K	692lm	160lm/W
150mm	4.3W	4000K	728lm	167lm/W
300mm	8.6W	3000K	1384lm	160lm/W
300mm	8.6W	4000K	1455lm	167lm/W
450mm	13W	3000K	2076lm	160lm/W
450mm	13W	4000K	2182lm	167lm/W
600mm	17.3W	3000K	2768lm	160lm/W
600mm	17.3W	4000K	2910lm	167lm/W

The Sovereign Linear Mono Wall Light borrows the beautifully sleek, minimal design of the Sovereign Broadline range. Utilising the latest LED technology ensures the highest quality and efficiency on the market.

Available in a range of sizes and outputs. Providing either uplighting or downlighting, the Wall Light is also available as an up/downlight under the Sovereign Duo Profile Wall Light range.

Fitted with integral electronic control gear as standard, with dimming & EM versions (remote) also available.

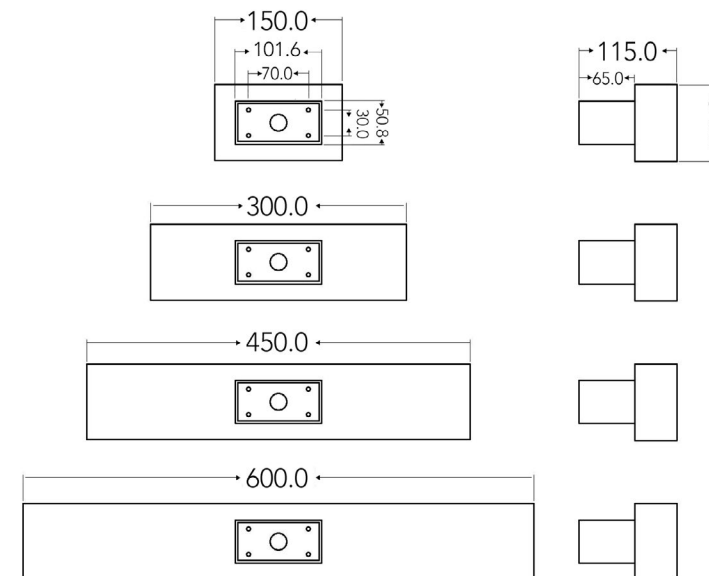

TECHNICAL SPECIFICATIONS

IP rating	IP40
CRI	>80
Lamp Life	50,000 hours
Light Source	Tridonic LLE
Voltage	240V
Driver	High efficiency
LED Warranty	5 Years

HOUSING

Material	Extruded aluminium
Finish	Powder coated
Protection Rating	Class 1
Optics	Opal diffuser
Weight	1.5kg
Mounting	Surface Mounted

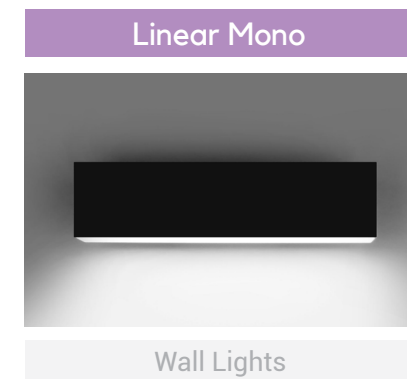

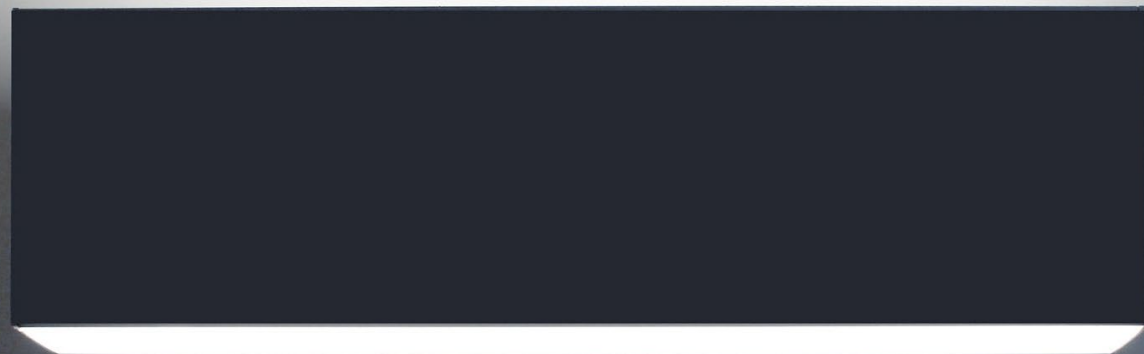

Product Family	Housing Colour	CCT	Suffix
S18514 150mm	/X5 Textured white	00 3000K	.8
S18515 300mm	/X4 Textured black	01 4000K	
S18516 450mm	/X2 Textured silver		
S18517 600mm			

Remote EM and dimmable options available - see page 50 for ordering info.

Linear Duo

Wall Light

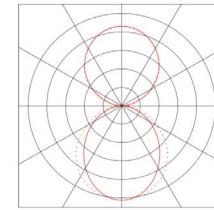

Size	Wattage	CCT	Lumens	Efficacy
150mm	10W	3000K	692 + 692lm	160lm/W
150mm	10W	4000K	727 + 727lm	167lm/W
300mm	17.3W	3000K	1384 + 1384lm	160lm/W
300mm	17.3W	4000K	1455 + 1455lm	167lm/W
450mm	26W	3000K	2076 + 2076lm	160lm/W
450mm	26W	4000K	2182 + 2182lm	167lm/W
600mm	33.1W	3000K	2624 + 2624lm	160lm/W
600mm	33.1W	4000K	2760 + 2760lm	167lm/W

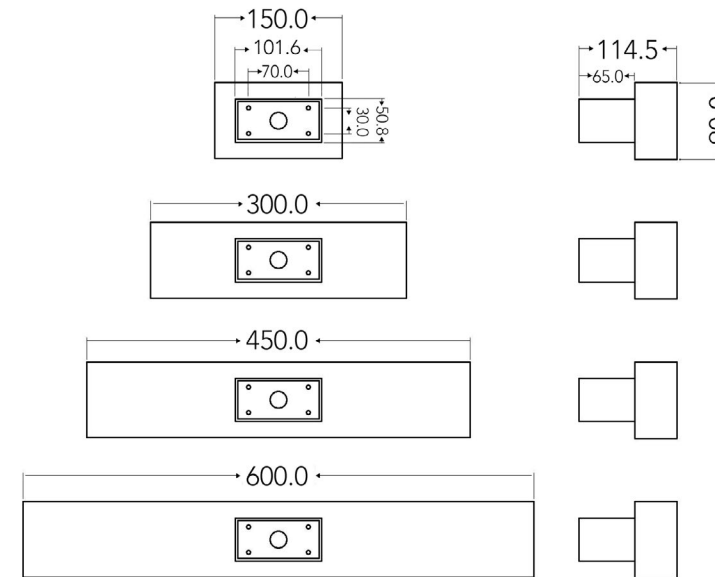

The Sovereign Linear Duo Wall Light borrows the beautifully sleek, minimal design of the Sovereign Broadline design.

Utilising the latest LED technology ensures the highest quality and efficiency on the market. Available in a range of sizes and outputs.

Providing both up and downlighting, the Wall Light is also available as either an up or downlight under the Sovereign Linear Mono range. Fitted with integral electronic control gear as standard, with dimming & EM versions (remote) also available.

TECHNICAL SPECIFICATIONS

IP rating	IP40
CRI	>80
Lamp Life	50,000 hours
Light Source	Tridonic LLE
Voltage	240V
Driver	High efficiency
LED Warranty	5 Years

HOUSING

Material	Extruded aluminium
Finish	Powder coated
Protection Rating	Class 1
Optics	Opal diffuser
Weight	1.5kg
Mounting	Surface Mounted

Linear Duo



Wall Lights

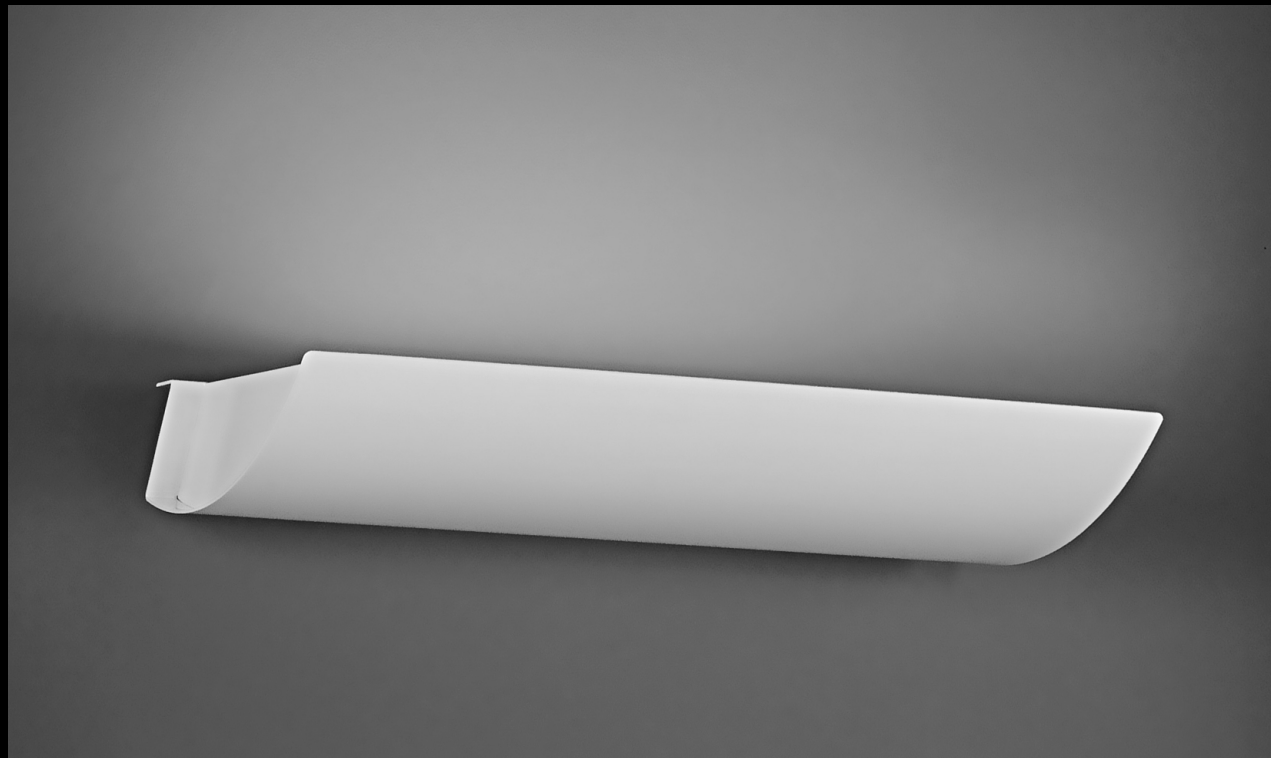

Product Family	Housing Colour	Version	Suffix
S98612 Slim Uplight	.05 White	00 3000K Up/down	.8
	.04 Black	01 4000K Up/down	
	.21 Silver	02 3000K Uplight	
		03 4000K Uplight	

EM and dimmable options available - see page 50 for ordering info.

Slim Uplight

Wall Light

LIGHT DETAILS

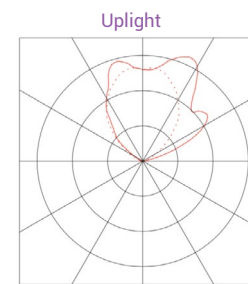

Wattage	CCT	Lumens	Efficacy
39W	3000K	5968lm	154lm/W
39W	4000K	6245lm	161lm/W

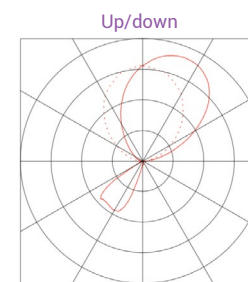

Wattage	CCT	Lumens	Efficacy
49W	3000K	5968 + 1326lm	154lm/W + 134lm/W
39W	4000K	6245 + 1388lm	161lm/W + 140lm/W

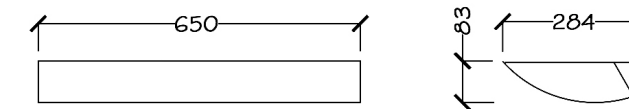

TECHNICAL SPECIFICATIONS

IP rating	IP40
CRI	>80
Lamp Life	50,000 hours
Light Source	Tridonic LLE
Voltage	240V
Driver	High efficiency
LED Warranty	5 Years

HOUSING

Material	Spun aluminium
Finish	Powder coated
Protection Rating	Class 1
Optics	Microprism
Weight	2.1kg
Mounting	Surface mounted

Taking our highly successful Slim Profile range into the future by completely re-designing the internal structure and incorporating the very latest Tridonic LLE range of high performance LED modules & drivers offering efficiency of over 140 lm/W.

Available in either uplight only or also available with downlight facility provided by separate LLE module located within the wall box. Emergency versions of the downlight version are also available.

All versions incorporate integral high efficiency non-dimmable drivers as standard, but can also be specified in any dimmable format.

Slim Uplight

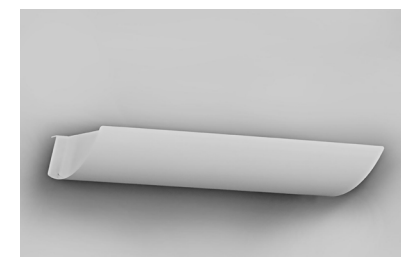

Wall Lights

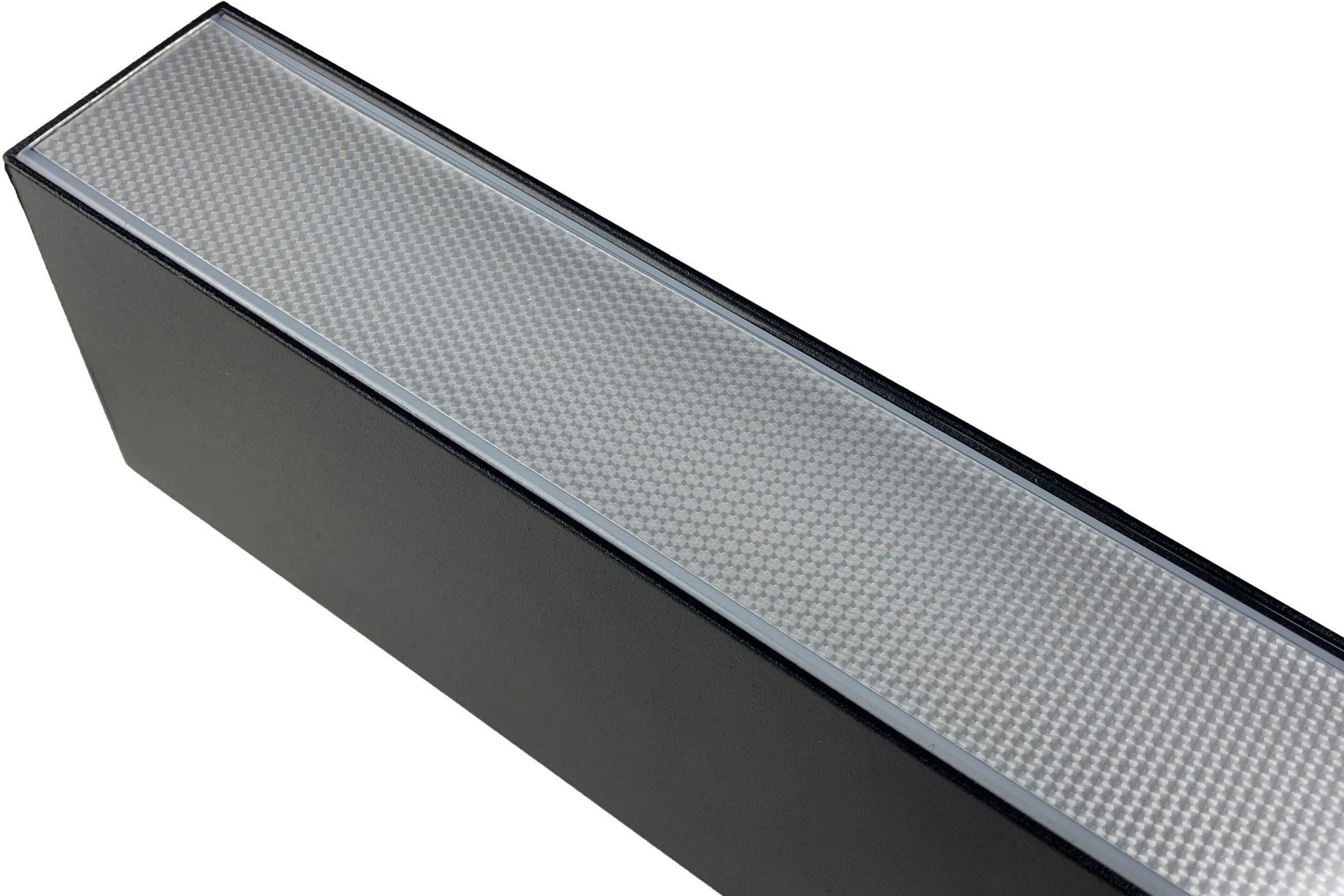

the
Cube
Wall Light
range

High output wall light with a classic design.
Ideal for larger interior applications.





Family	Beam	Housing Colour	Version	Suffix
S98864 Cube Up/Down	FLFL Flood up & down	.05 White	01 3000K 25.24W	.8
	SPFL Spot up / flood down	.04 Black	02 4000K 25.24W	
		.21 Silver	03 3000K 36.84W	
			04 4000K 36.84W	

EM and dimmable options available - see page 50 for ordering info.

Cube Up/Down

Wall Light

Wattage	CCT	Lumens	Efficacy
25.24W	3000K	1932lm x 2	153lm/W
25.24W	4000K	1932lm x 2	157lm/W
36.84W	3000K	2745lm x 2	149lm/W
36.84W	4000K	2837lm x 2	154lm/W

Designed to complement our existing ranges of wall lights, this Cube Up/Downlight is the LED version of our popular classic CFL design, perfect for larger interior projects including churches, community halls etc.

Available in 3000K or 4000K, and in a range of outputs. Also available as up or downlight on request.

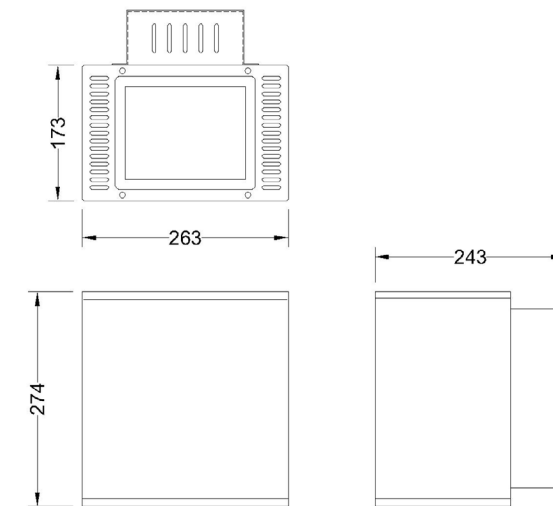

TECHNICAL SPECIFICATIONS

IP rating	IP20
CRI	>80
Lamp Life	50,000 hours
Light Source	SLE
Voltage	240V
Driver	High efficiency
LED Warranty	5 Years

HOUSING

Material	Aluminium
Finish	Powder coated
Protection Rating	Class 1
Optics	Glass
Weight	4.75kg
Mounting	Surface Mounted

Cube Up/Down



Wall Lights

the
Ecoblade
wall light ranges

The Sovereign Ecoblade range is the result of extensive research and development by Commercial Lighting Systems. Matching a minimalist style with impressive efficiency and illumination makes the Ecoblade ideal for office environments.





Product Family	Housing Colour	CCT & Output	Suffix
S18541 Ecoblade Uplight	.X5 Textured White	04S 3000K 300mm	.8
S18542 Ecoblade Slot Uplight	.X4 Textured Black	05S 4000K 300mm	
	.X2 Textured Silver	04 3000K 400mm	
		05 4000K 400mm	
		00 3000K 600mm	
		01 4000K 600mm	
		08 3000K 900mm	
		09 4000K 900mm	

EM and dimmable options available - see page 50 for ordering info.

Ecoblade Uplight

Wall Light

LIGHT DETAILS

Size	Wattage	CCT	Lumens	Efficacy
300mm	13W	3000K	2030lm	156lm/W
300mm	13W	4000K	2120lm	163lm/W
400mm	13W	3000K	2030lm	156lm/W
400mm	13W	4000K	2120lm	163lm/W
600mm	26W	3000K	4050lm	156lm/W
600mm	26W	4000K	4240lm	163lm/W
900mm	39W	3000K	6080lm	156lm/W
900mm	39W	4000K	6360lm	163lm/W

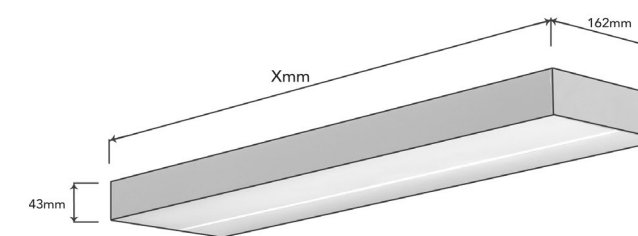
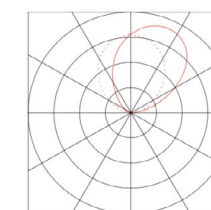

TECHNICAL SPECIFICATIONS

IP rating	IP40
CRI	>80
Lamp Life	50,000 hours
Light Source	Tridonic LLE
Voltage	240V
Driver	High efficiency
LED Warranty	5 Years

HOUSING

Material	Extruded aluminium
Finish	Textured powder coated
Protection Rating	Class 1
Optics	Microprism
Weight	2.5kg - 5.4kg
Mounting	Surface mounted

A range of exceptionally high performance, top quality wall mounted uplighters, specifically designed around the latest high efficiency Tridonic LLE modules, offering superb performance of up to 163lm/W. Available in a range of styles with an additional front

Main housing produced from extruded aluminium with integral passive thermal management. All versions supplied with Microprism diffuser for optimum light transmission and visual comfort.

Finished in textured polyester powder coat with standard finishes in white, black and silver, with other BS/RAL colours available to order.

Ecoblade Uplight



Wall Lights



Product Family	Housing Colour	CCT & Output	Suffix
S18541 Ecoblade	.X5 Textured White	06 3000K 400mm	.8
S18542 Ecoblade Slot	.X4 Textured Black	07 4000K 400mm	
	.X2 Textured Silver	02 3000K 600mm	
		03 4000K 600mm	
		10 3000K 900mm	
		11 4000K 900mm	

EM and dimmable options available - see page 50 for ordering info.

Ecoblade Up/Down

Wall Light

LIGHT DETAILS

Size	Wattage	CCT	Lumens	Efficacy
400mm	20W	3000K	3043lm	152lm/W
400mm	20W	4000K	3180lm	159lm/W
600mm	33W	3000K	5063lm	153lm/W
600mm	33W	4000K	5300lm	161lm/W
900mm	52W	3000K	8105lm	156lm/W
900mm	52W	4000K	8479lm	163lm/W

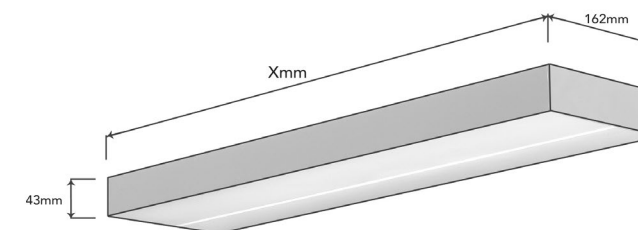
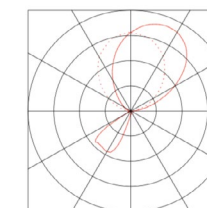

A range of exceptionally high performance, top quality wall mounted uplighters, specifically designed around the latest high efficiency Tridonic LLE modules, offering superb performance of up to 163lm/W. Available in a range of styles including uplight only or up/downlight.

Main housing produced from extruded aluminium with integral passive thermal management. All versions supplied with Microprism diffuser for optimum light transmission and visual comfort.

Finished in textured polyester powder coat with standard finishes in white, black and silver, with other BS/RAL colours available to order.

TECHNICAL SPECIFICATIONS

IP rating	IP40
CRI	>80
Lamp Life	50,000 hours
Light Source	Tridonic LLE
Voltage	240V
Driver	High efficiency
LED Warranty	5 Years

HOUSING

Material	Extruded aluminium
Finish	Textured powder coated
Protection Rating	Class 1
Optics	Microprism
Weight	2.5 - 5.4kg
Mounting	Surface mounted

Ecoblade Up/Down



Wall Lights

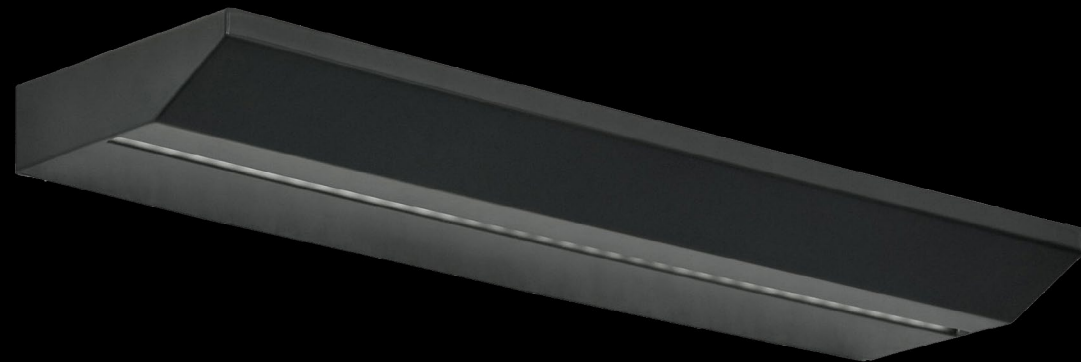

Product Family	Housing Colour	CCT & Output	Suffix
S18540 Ecoblade Wedge	.X5 Textured White	04S 3000K 300mm Uplight	.8
	.X4 Textured Black	05S 4000K 300mm Uplight	
	.X2 Textured Silver	04 3000K 400mm Uplight	
		05 4000K 400mm Uplight	
		00 3000K 600mm Uplight	
		01 4000K 600mm Uplight	
		08 3000K 900mm Uplight	
		09 4000K 900mm Uplight	
		06 3000K 400mm Up/Down	
		07 4000K 400mm Up/Down	
		02 3000K 600mm Up/Down	
		03 4000K 600mm Up/Down	
		10 3000K 900mm Up/Down	
		11 4000K 900mm Up/Down	

EM and dimmable options available - see page 50 for ordering info.

Ecoblade Wedge

Wall Light

LIGHT DETAILS

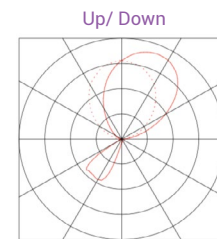
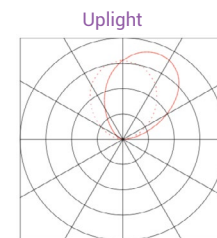

Size	Wattage	CCT	Lumens	Efficacy
300mm	13W	3000K	2030lm	156lm/W
300mm	13W	4000K	2120lm	163lm/W
400mm	13W	3000K	2030lm	156lm/W
400mm	13W	4000K	2120lm	163lm/W
600mm	26W	3000K	4050lm	156lm/W
600mm	26W	4000K	4240lm	163lm/W
900mm	39W	3000K	6080lm	156lm/W
900mm	39W	4000K	6360lm	163lm/W

Size	Wattage	CCT	Lumens	Efficacy
400mm	20W	3000K	3043lm	152lm/W
400mm	20W	4000K	3180lm	159lm/W
600mm	33W	3000K	5063lm	153lm/W
600mm	33W	4000K	5300lm	161lm/W
900mm	52W	3000K	8105lm	156lm/W
900mm	52W	4000K	8479lm	163lm/W

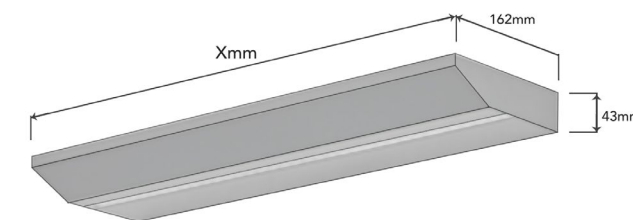

TECHNICAL SPECIFICATIONS

IP rating	IP40
CRI	>80
Lamp Life	50,000 hours
Light Source	Tridonic LLE
Voltage	240V
Driver	High efficiency
LED Warranty	5 Years

HOUSING

Material	Extruded aluminium
Finish	Textured powder coated
Protection Rating	Class 1
Optics	Microprism
Weight	2.5 - 5.4kg
Mounting	Surface mounted

A range of exceptionally high performance, top quality wall mounted uplighters, specifically designed around the latest high efficiency Tridonic LLE modules, offering superb performance of up to 163lm/W. Available in a range of styles including uplight only or up/downlight.

Main housing produced from extruded aluminium with integral passive thermal management. All versions supplied with Microprism diffuser for optimum light transmission and visual comfort.

Finished in textured polyester powder coat with standard finishes in white, black and silver, with other BS/RAL colours available to order.

Ecoblade Wedge

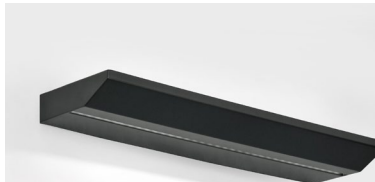

Wall Lights

the
**Slimline
Square**
range

An elegant wall or ceiling surface mounted luminaire, providing soft even light through the two oval diffusers.





Product Family	Housing Colour	CCT	Suffix
S98955 Slimline Square	.05 White	00 3000K	.8
	.04 Black	01 4000K	
	.21 Silver		

EM and dimmable options available - see page 50 for ordering info.

Slimline Square

Wall Light

LIGHT DETAILS

Wattage	CCT	Lumens	Efficacy
12.5W	3000K	1600lm	133lm/W
12.5W	4000K	1730lm	138lm/W

Our Sovereign Slimline Square is an ideal product for both interior ceiling and wall-mounted applications. Utilising the latest Tridonic QLE LED modules, the Slimline Square offers competitive LED efficacy and the most up-to-date specifications. It's clean and elegant steel design is a statement of quality and durability, with the subtle polycarbonate opal diffusers providing a soft and even light.

The Sovereign Slimline Square is supplied with an integrated high efficiency driver as standard, but can also be specified with dimmable drivers to suit any dimming protocol.

EM versions and corridor functions are also available, while the housing can be powder-coated to any colour, with black, white and silver as standard.

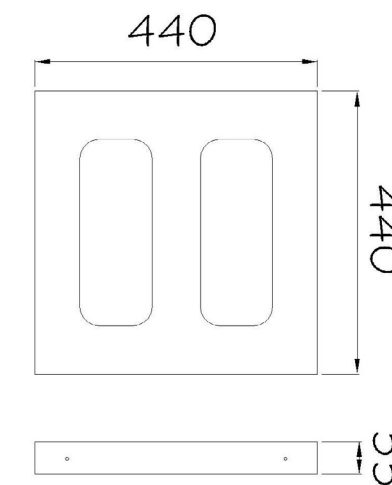

TECHNICAL SPECIFICATIONS

IP rating	IP40
CRI	>80
Lamp Life	50,000 hours
Light Source	Tridonic QLE
Voltage	240V
Driver	High efficiency
LED Warranty	5 Years

HOUSING

Material	Steel
Finish	Powder coated
Style	Alternative front cover options
Protection Rating	Class 1
Optics	Opal diffuser
Weight	5.5kg
Mounting	Surface mounted

Slimline Square



Wall Lights

the
Round
wall light ranges

A beautiful, minimal luminaire available in surface and recessed versions. Our Pizza range offers alternative designs with more subtle illumination outputs.





Product Family		Housing Colour		CCT		Suffix
S18636	Round Size 1	.05	White	06	3000K	.8
S18637	Round Size 2	.04	Black	07	4000K	
S18638	Round Size 3	.21	Silver			

EM and dimmable options available - see page 50 for ordering info.

Round Surface

Wall Light

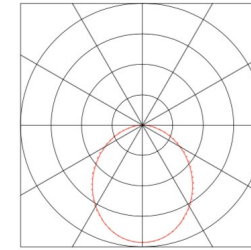

LIGHT DETAILS

Size	Wattage	CCT	Lumens	Efficacy
400mm	30W	3000K	2500lm	83lm/W
400mm	30W	4000K	2700lm	90lm/W
500mm	40W	3000K	3600lm	90lm/W
500mm	40W	4000K	3800lm	95lm/W
600mm	48W	3000K	4500lm	94lm/W
600mm	48W	4000K	4800lm	100lm/W

Size 1

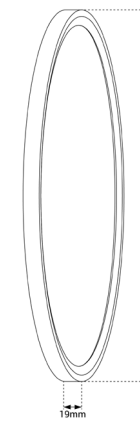

Size 2

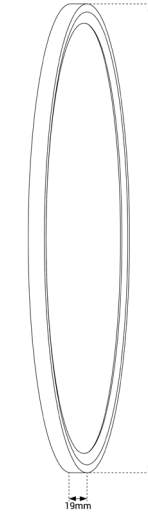

Size 3

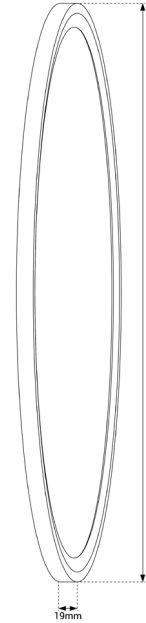

TECHNICAL SPECIFICATIONS

IP rating	IP40
CRI	>80
Lamp Life	50,000 hours
Light Source	Side Emitting SMD
Voltage	240V
Driver	High efficiency
LED Warranty	5 Years

HOUSING

Material	Spun aluminium
Finish	Powder coated
Protection Rating	Class 1
Optics	Opal diffuser
Weight	3.5kg - 5.8kg
Mounting	Surface mounted

These exceptionally slim circular units provide high levels of illumination with a pleasingly soft appearance. With its minimally elegant design, the Round Surface Panels offer a discrete yet distinctive solution for both ceiling downlighting and as wall mounted luminaires.

Supplied complete with standard high efficiency driver, but can also be specified with dimmable drivers to suit any dimming protocol. EM versions also available, with all components located within the spun aluminium rear gear housing for ease of installation.

Round Surface



Wall Lights



Product Family	Bezel Colour	CCT	Suffix
S18820 Pizza	.05 White	00 Size 1 3000K	.8
	.04 Black	01 Size 1 4000K	
	.21 Silver	02 Size 2 3000K	
		03 Size 2 4000K	

EM and dimmable options available - see page 50 for ordering info.

Pizza Surface

Wall Light

LIGHT DETAILS - DIRECT

Wattage	CCT	Lumens	Efficacy
9.5W	3000K	1535lm	161lm/W
9.5W	4000K	1606lm	168lm/W
15W	3000K	2477lm	165lm/W
15W	4000K	2592lm	173lm/W

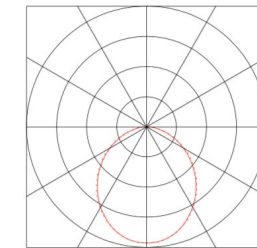

A traditionally designed and produced circular luminaire available in two sizes and designs.

The spun aluminium housing incorporates an integrated metal geartray for optimal heat dissipation, with the polycarbonate front diffuser providing a balanced indirect light output. Larger version featuring a frameless full diameter injection-moulded polycarbonate housing.

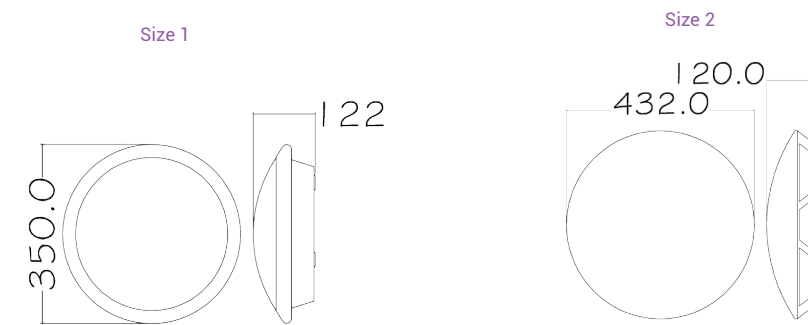

TECHNICAL SPECIFICATIONS

IP rating	IP40
CRI	>80
Lamp Life	50,000 hours
Light Source	Tridonic CLE
Voltage	240V
Driver	High efficiency
LED Warranty	5 Years

HOUSING

Material	Spun aluminium (size 1) / polycarb (size 2)
Finish	Powder coated
Protection Rating	Class 1
Optics	Opal diffuser
Weight	1.4kg (size 1) / 2kg (size 2)
Mounting	Surface mounted

Pizza Surface



Wall Lights

the
**Exterior
Bulkhead**
range

An attractive and robust solution for walkway, tunnel, car park and storage area illumination.





Product Family	Bezel Colour	Style	Suffix
S78336 Exterior Bulkhead	.05 White	00 9.5W 3000K Plain	.8
	.04 Black	01 9.5W 4000K Plain	
		02 17W 3000K Plain	
		03 9.5W 3000K Eyelid	
		04 9.5W 3000K Eyelid	
		05 9.5W 4000K Eyelid	
		06 17W 3000K Eyelid	
		07 17W 4000K Eyelid	

EM and dimmable options available - see page 50 for ordering info.

Exterior Bulkhead

Wall Light

LIGHT DETAILS

Wattage	CCT	Lumens	Efficacy
9.5W	3000K	1530lm	160lm/W
9.5W	4000K	1600lm	169lm/W
17W	3000K	2540lm	158lm/W
17W	4000K	2660lm	158lm/W

With its IP65 rating the Bulkhead is ideal for exterior applications. Available in various outputs and colour temperatures.

Available in both a standard and eyelid design.

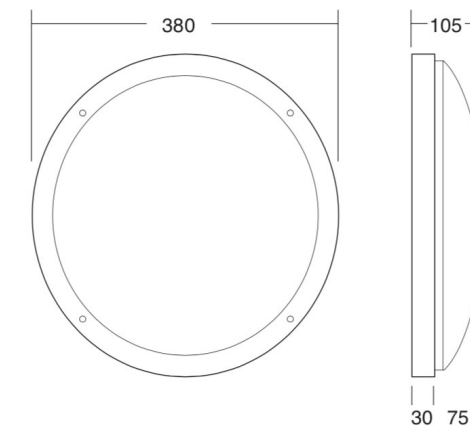
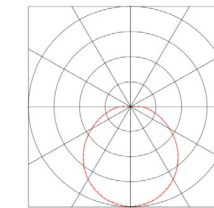

TECHNICAL SPECIFICATIONS

IP rating	IP65
CRI	>80
Lamp Life	50,000 hours
Light Source	Tridonic SLE
Voltage	240V
Driver	High efficiency
LED Warranty	5 Years

HOUSING

Material	Die-cast aluminium
Style	Plain / eyelid
Finish	Textured powder coated
Protection Rating	Class 1
Optics	Polycarbonate opal diffuser
Weight	2.5kg - 5.4kg
Mounting	Surface mounted

Exterior Bulkhead



Wall Lights

the
Spun Aluminium
wall light ranges

Our classic spun aluminium wall light ranges have maintained their prominent place in the Sovereign catalogue through constant updates. Utilising the latest technology, these timeless designs provide high quality illumination with excellent efficiency.





Product Family	Housing Colour	Version	Suffix
S18506 Saturn	.05 White	00 3000K 56W	.8
	.04 Black	01 4000K 56W	
	.21 Silver	02 3000K 84W	
		03 4000K 84W	

EM and dimmable options available - see page 50 for ordering info.

Saturn

Wall Light

LIGHT DETAILS - DIRECT

Wattage	CCT	Lumens	Efficacy
56W	3000K	7640 + 640lm	146lm/W
56W	4000K	8000 + 670lm	154lm/W
84W	3000K	11460 + 640lm	146lm/W
84W	4000K	1200 + 670lm	154lm/W

A classic Sovereign design updated to the latest LED technology, the Sovereign Saturn Up/Downlight provides high quality, energy efficient lighting for interior environments.

Subtly offset from the wall, the Saturn's design offers both the main uplighting, as well as a downlight facility from a secondary light source integrated within the wall box.

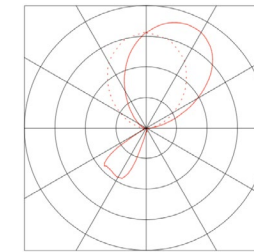

The Saturn's microprism diffuser generates a pleasingly soft and uniform spread, while the high-purity aluminium spun housing ensures quality and product longevity. Integral control gear as standard.

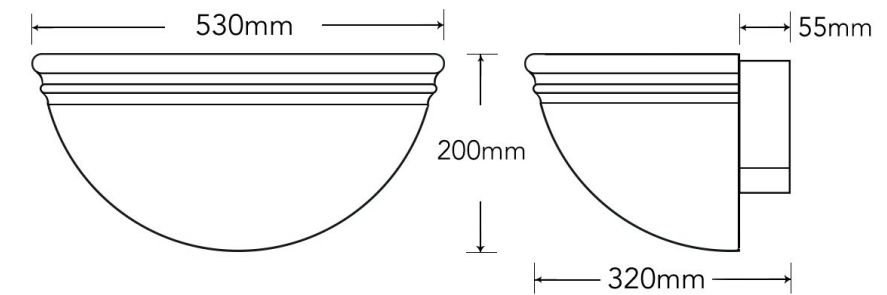

TECHNICAL SPECIFICATIONS

IP rating	IP20
CRI	>80
Lamp Life	50,000 hours
Light Source	Tridonic LLE
Voltage	240V
Driver	High efficiency
LED Warranty	5 Years

HOUSING

Material	Spun aluminium
Finish	Powder coated
Protection Rating	Class 1
Optics	Microprism
Weight	2.1kg
Mounting	Surface mounted

Saturn



Wall Lights



Product Family	Housing Colour	CCT	Suffix
S18552 Mini QS Up	.05 White	00 3000K	.8
	.04 Black	01 4000K	
	.21 Silver		

EM and dimmable options available - see page 50 for ordering info.

Mini QS Uplight

Wall Light

LIGHT DETAILS

Wattage	CCT	Lumens	Efficacy
8.7W	3000K	1280lm	147lm/W
8.7W	4000K	1340lm	153lm/W

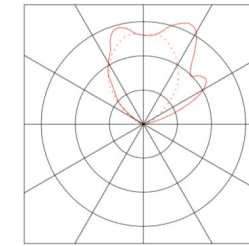

A classic design updated to the latest LED technology, this Sovereign Mini Quartersphere provides uplight illumination with the microprism diffuser generating a pleasingly uniform spread. Main housing produced from high purity aluminium with integral control gear fitted as standard.

The Sovereign Mini Quartersphere is also available as an up/downlight (Product Code S18552), see next page for details.

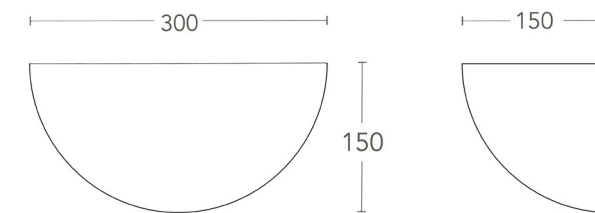

TECHNICAL SPECIFICATIONS

IP rating	IP20
CRI	>80
Lamp Life	50,000 hours
Light Source	Tridonice LLE
Voltage	240V
Driver	High efficiency
LED Warranty	5 Years

HOUSING

Material	Spun aluminium
Finish	Powder coated
Protection Rating	Class 1
Optics	Microprism
Weight	1.2kg
Mounting	Surface mounted

Mini QS Uplight



Wall Lights



Product Family	Housing Colour	CCT	Suffix
S18551 Mini QS Up/down	.05 White	00 3000K	.8
	.04 Black	01 4000K	
	.21 Silver		

EM and dimmable options available - see page 50 for ordering info.

Mini QS Up/Down

Wall Light

LIGHT DETAILS

Wattage	CCT	Lumens	Efficacy
10.9W	3000K	1280lm + 320lm	147lm/W
10.9W	4000K	1340lm + 330lm	153lm/W

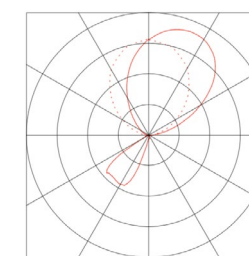

A classic design updated to the latest LED technology, this Sovereign Mini Quartersphere provides up and downlight illumination with the microprism diffuser generating a pleasingly uniform spread. Main housing produced from high purity aluminium with integral control gear fitted as standard.

The Sovereign Mini Quartersphere is also available as an uplight only (Product Code S18550), see previous page for more details.

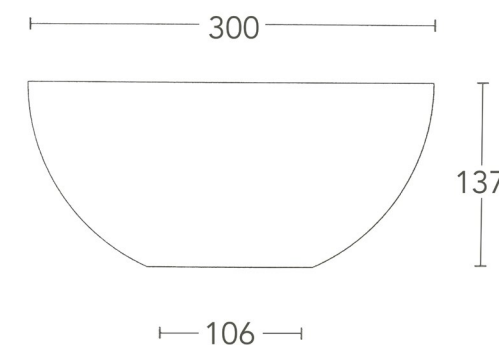

TECHNICAL SPECIFICATIONS

IP rating	IP20
CRI	>80
Lamp Life	50,000 hours
Light Source	Tridonice LLE
Voltage	240V
Driver	High efficiency
LED Warranty	5 Years

HOUSING

Material	Spun aluminium
Finish	Powder coated
Protection Rating	Class 1
Optics	Microprism
Weight	1.2kg
Mounting	Surface mounted

Mini QS Up/Down

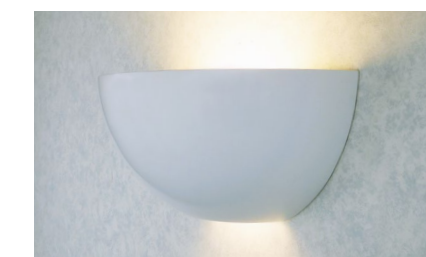

Wall Lights



Product Family	Housing Colour	Version	Suffix
S18500 Quarter Sphere	.05 White	00 3000K 26.2W	.8
	.04 Black	01 4000K 26W	
	.21 Silver	02 3000K 39.2W	
		03 4000K 39W	

EM and dimmable options available - see page 50 for ordering info.

Quarter Sphere

Wall Light

LIGHT DETAILS

Wattage	CCT	Lumens	Efficacy
26.2W	3000K	3820lm	146lm/W
26W	4000K	4000lm	154lm/W
39.2W	3000K	5730lm	146lm/W
39W	4000K	6000lm	154lm/W

A high quality fully adjustable recessed downlight, allowing a 360° rotation and 45° tilt. An updated version of a mainstay of the Sovereign range, the Scoop utilises the most up-to-date LED technology to ensure optimum efficiency and light quality.

Available in any BS / RAL colour, with dimmable and emergency variants available. Offered with either 3000K or 4000k colour temperature

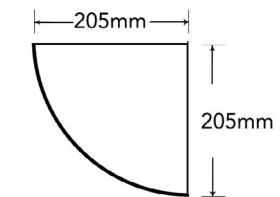
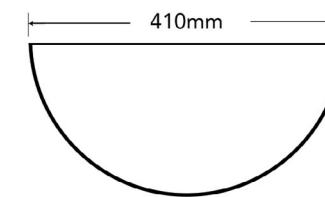
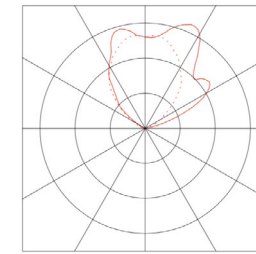

TECHNICAL SPECIFICATIONS

IP rating	IP20
CRI	>80
Lamp Life	50,000 hours
Light Source	Tridonic LLE
Voltage	240V
Driver	High efficiency
LED Warranty	5 Years

HOUSING

Material	Spun aluminium
Finish	Powder coated
Protection Rating	Class 1
Optics	Microprism
Weight	2.1kg
Mounting	Surface mounted

Quarter Sphere

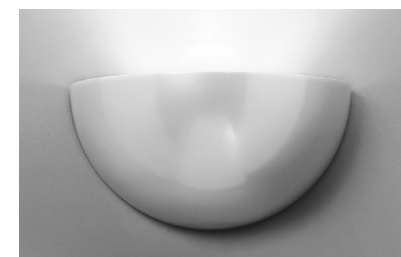

Wall Lights

Dimming, Emergency & Lighting Control

All of our Wall Lights are available with a full range of EM and lighting control options. To specify products with our most popular lighting controls, insert the relevant code between the main product code and the suffix.

N.B.: When specifying control options without Emergency lighting options, include /10 under the Emergency selection (do not leave blank).

Product code	EM & Lighting Control Insert		Suffix
	Emergency	Control	
	/10 Non-EM	0 On / off	.8
	/11 Non maintained EM	1 1-10V dimming	
	/14 Maintained 3HR EM	2 DALI dimming	
	/16 DALI self test EM	5 Switch dim	
		6 DMX	
		7 Bluetooth	

Example: **S98612.2100.8**
Slim Uplight / Silver / 3000K Up/down

S98612.2100/106
Slim Uplight / Silver / 3000K Up/down / Non EM / DMX control

*For more information about our control options,
just get in touch with our team.*

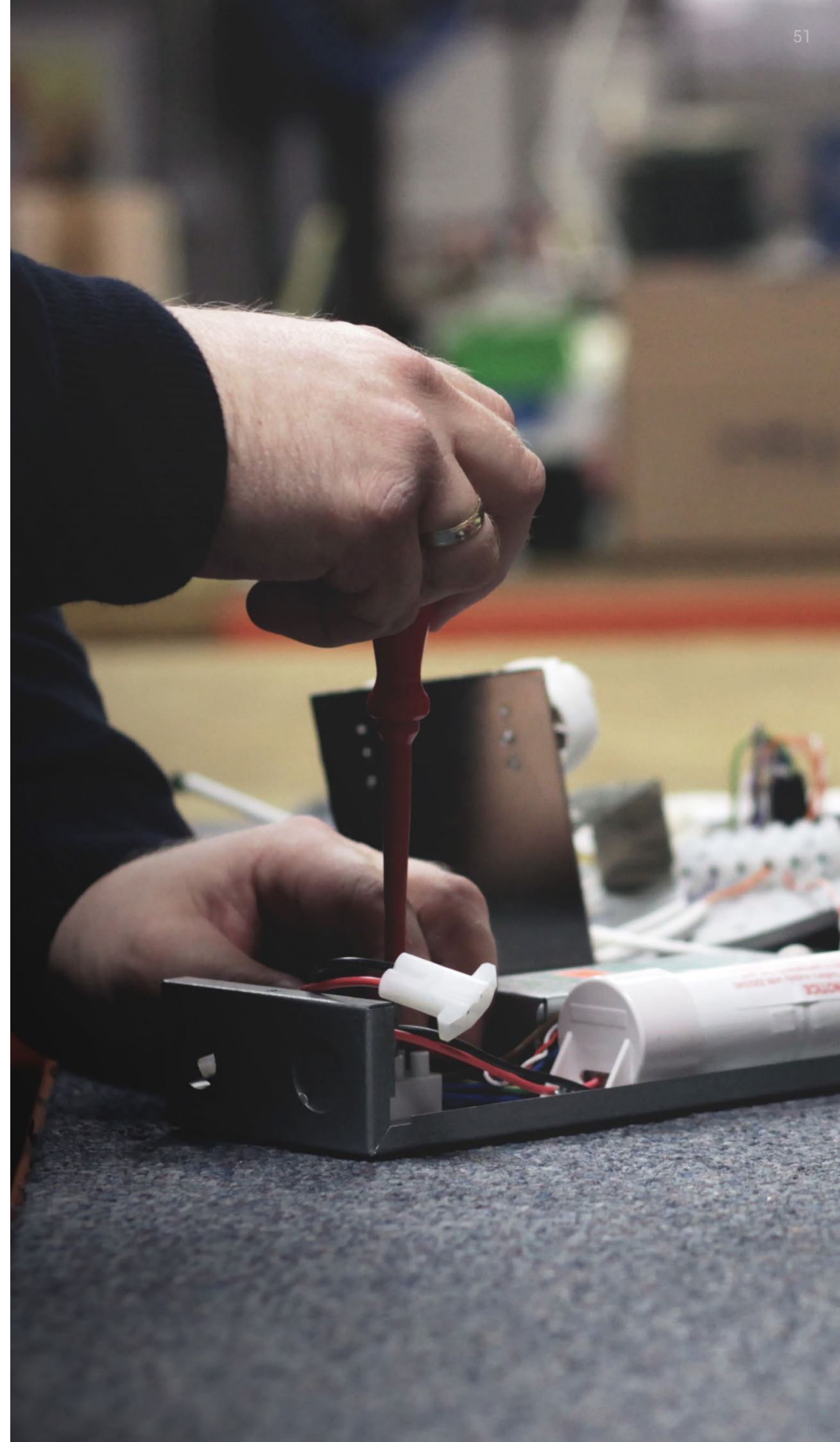

Bespoke Design

Product Modification

This catalogue lists only some of the options our Sovereign products offer. Commercial Lighting has extensive experience creating custom adaptations for our clients.

Need a specific housing colour, light source or bespoke colour rendering index? We can help.

Custom Product Design

Need a unique feature pendant, a specific housing design, or a solution no currently offered in our Sovereign range? Get in touch.

Many of our Sovereign products began as custom designs made in collaboration with clients.

Lighting Solutions

Our facilities include a dedicated in-house design team, metal workshop, in-house powder coating plant, and a team of experienced electrical assemblers.

This enables us to develop completely bespoke lighting solutions for any project.



the ReVive service

Our ReVive service puts sustainability at the heart.

Utilising 20+ years experience in sensitive restoration and refurbishment, Commercial Lighting gives old products new life, bringing them in line with the very latest standards, efficiency and performance.

The ReVive process:

- | | | |
|---|--------------|---|
| 1 | Assessment | We'll discuss all details of the current system with you to assess viability. We might ask for a sample or arrange collection via a site visit. |
| 2 | Proposal | Our technical team will create a full proposal, identifying the best solution for your project. This will comparison between current and proposed new fittings. |
| 3 | First-off | Our in house specialist production team will produce a sample for approval before full production. Depending on complexity, the conversions can be done in our manufacturing facilities, or custom upgrade kits can be sent for conversion on site. |
| 4 | Refurbish | We refurbish and upgrade all your products and apply rigorous testing procedures. |
| 5 | Installation | Your products are returned and re-installed using existing fixings for minimal disruption. Your fittings will be covered by our 5 year comprehensive warranty. |



££

Cheaper than
buying new



Less
carbon impact



Less
waste



Improved
efficiency



Better
illumination



Extended
lifetime

About us

Commercial Lighting Systems Ltd was established in Hampshire in 1991. The company is dedicated to offering the best quality, energy-efficient lighting to the UK market.

Our business is client-led, and made up of three divisions: reputable product ranges, bespoke design, and our flagship ReVive service for restoring and updating older lighting systems.

With almost 30 employees, many working here for over 20 years, our size lets us handle projects of any size. This allows us to maintain a personal approach to business, particularly advantageous for projects with unique specifications.

Our Values

How we do business is just as important as the end product. Our approach is built around quality, honesty, and sustainability.

We continually invest in technologies that help us minimise our environmental impact. From solar panels and full EV fleet to our minimal waste policy, we ensure every stage of our operations is considered for its impact on the environment.





SOVEREIGN®

The signature range from
Commercial Lighting Systems Ltd